

ASSEMBLY INSTRUCTIONS & PARTS IDENTIFICATION BENCH

Thank you for purchasing this quality product. Be sure to check all packing material carefully for small parts that may have come loose inside the carton during shipment.

Hardware kit		
No	Q'Ty	Description
A	12 pcs	Lock Washer 5/16"
B	12 pcs	Flat Washer 5/16"
C	8 pcs	Bolt 1/4"x 2"
D	4 pcs	Bolt 1/4"x 1.5"
E	1 pc	Allen Key

Key Parts			
No	Code	Q'Ty	Description
1	A	6 pcs	Floor glide
2	B	1 pc	Bench Seat
3	C	4 pcs	Bench Corner Legs
4	D	2 pcs	Bench Middle Legs

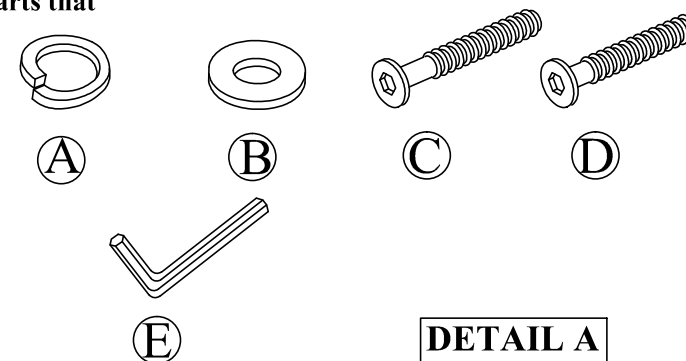

Remove bottom seat material before setup

STEP 1

- Carefully lay Bench seat up side down on a smooth flat surface to prevent scratches.
- Affix a leg (3), to each corner of the bench seat as shown in Detail (A) using a flat washer (B), lock washer(A) and bolt (C).
- Affix a middle leg (4) to the bench seat as shown in Detail (B) using a flat washer(B) , lock washer(A) and Bolt(D).

FABRIC CONTENT : 100% POLYESTER
CLEANING CODE "W"

Water-based cleaning agents or foam may be use.
Never use tap water. Use distilled water, as tap water contains minerals that may cause rings or fading. Pre-test on an inconspicuous area.

