

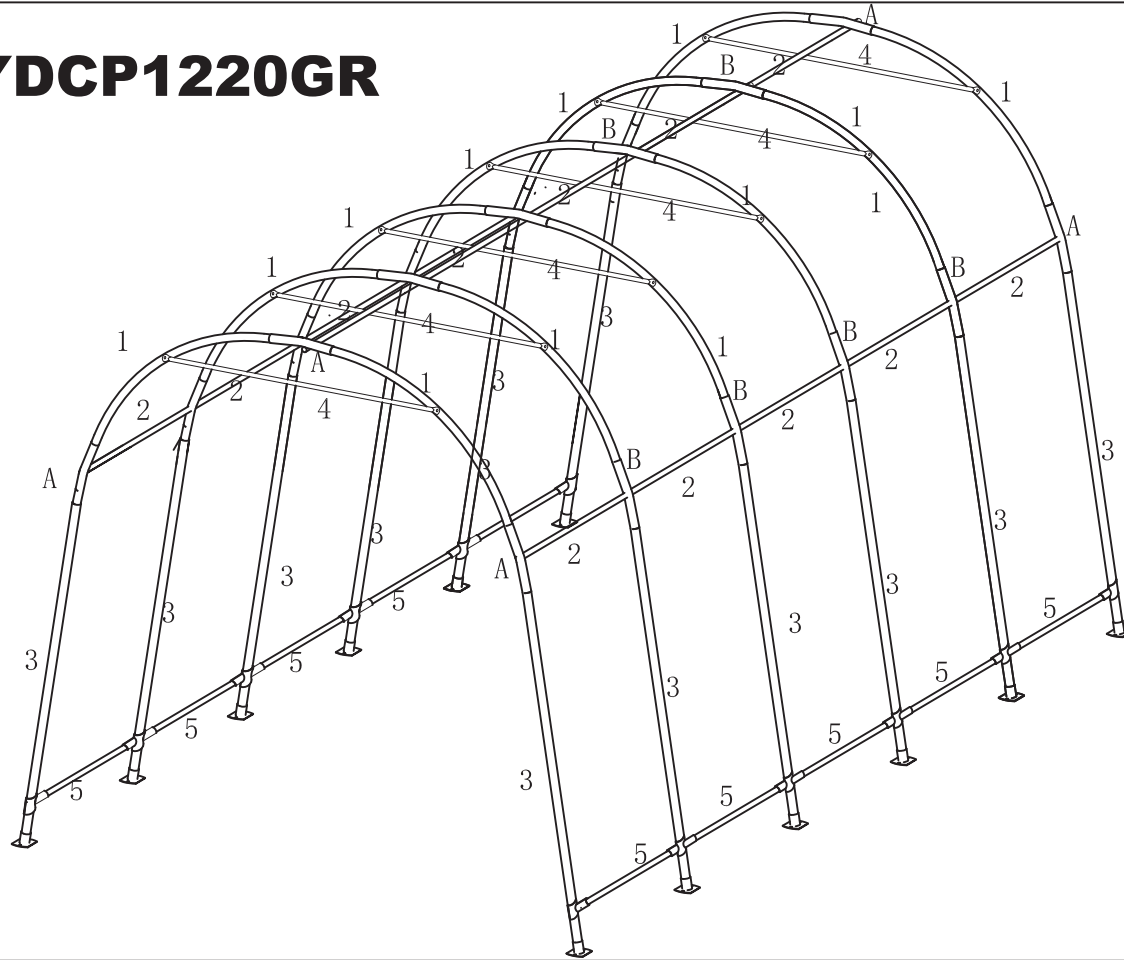











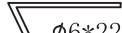

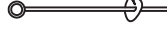

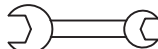
YDCP1220GR

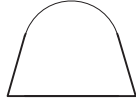
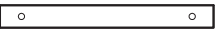

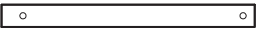
Description	Quantity
 M8 × 50	60+2
 M8 × 50	4
 M6 × 45	40+2
 φ6*220MM	24
	4
 φ6*300mm	4
 φ5	4
	2
	2

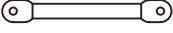
Description	Quantity	Description	Quantity	Description	Quantity
1# 	12	A# 	6	F# 	1
2# 	15	B# 	12	G# 	36
3# 	12	C# 	12	I# 	8
4# 	6	D# 	1	J# 	16
5# 	10	E# 	1		

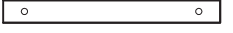
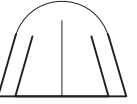
1.

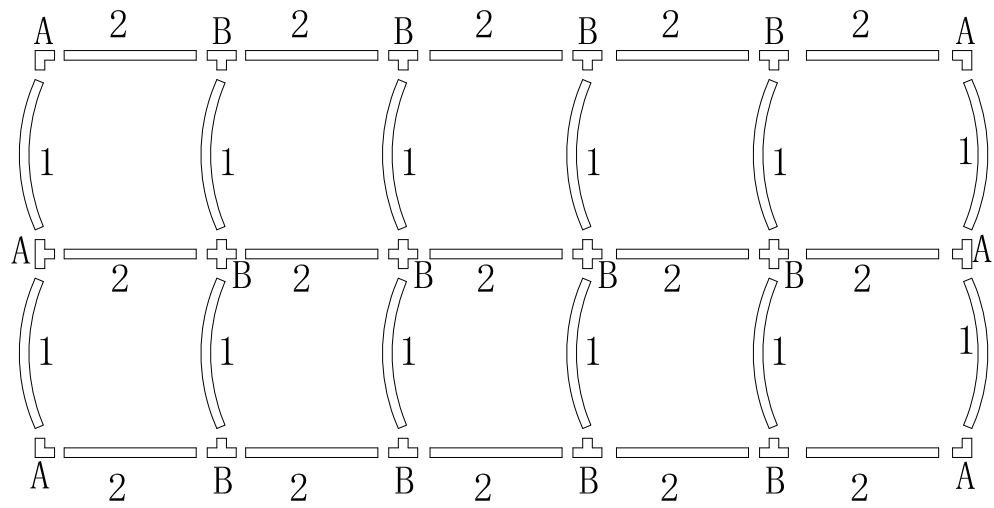

2.

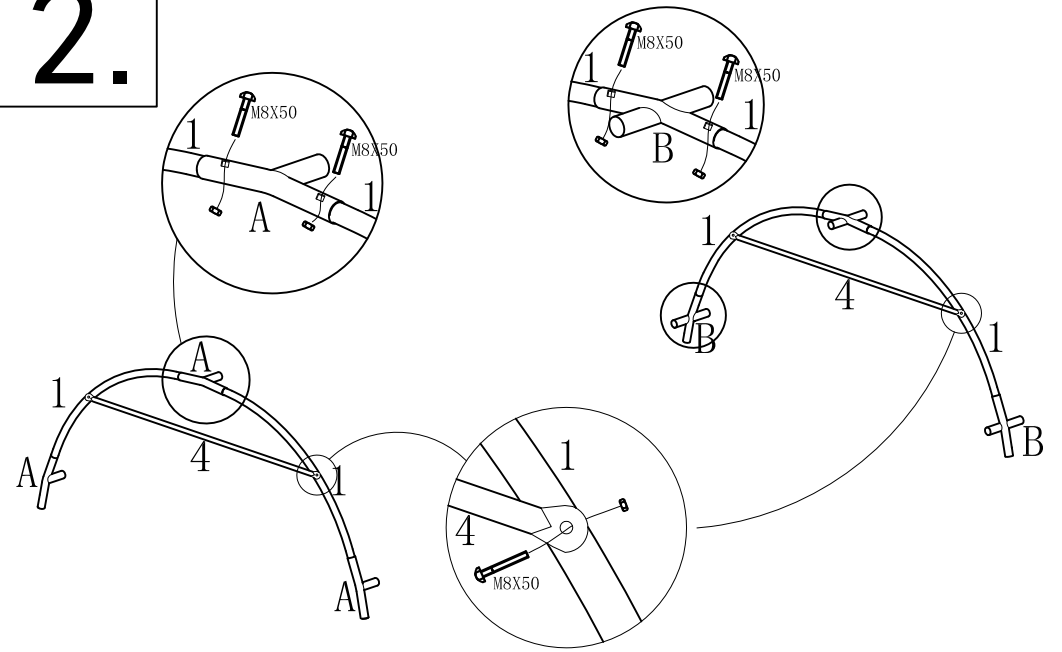

3.

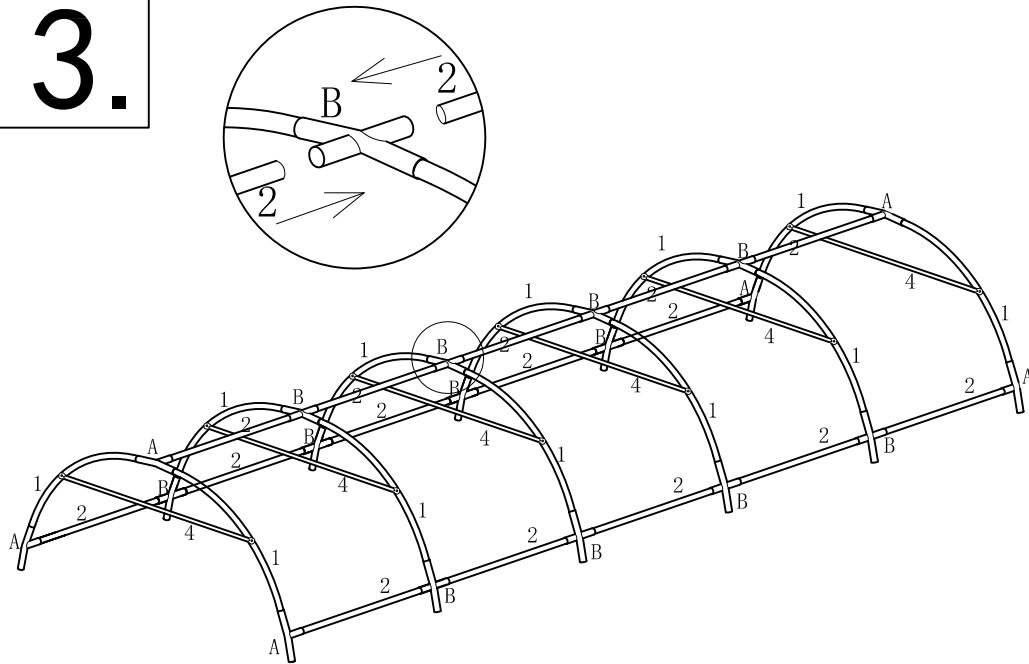

4.

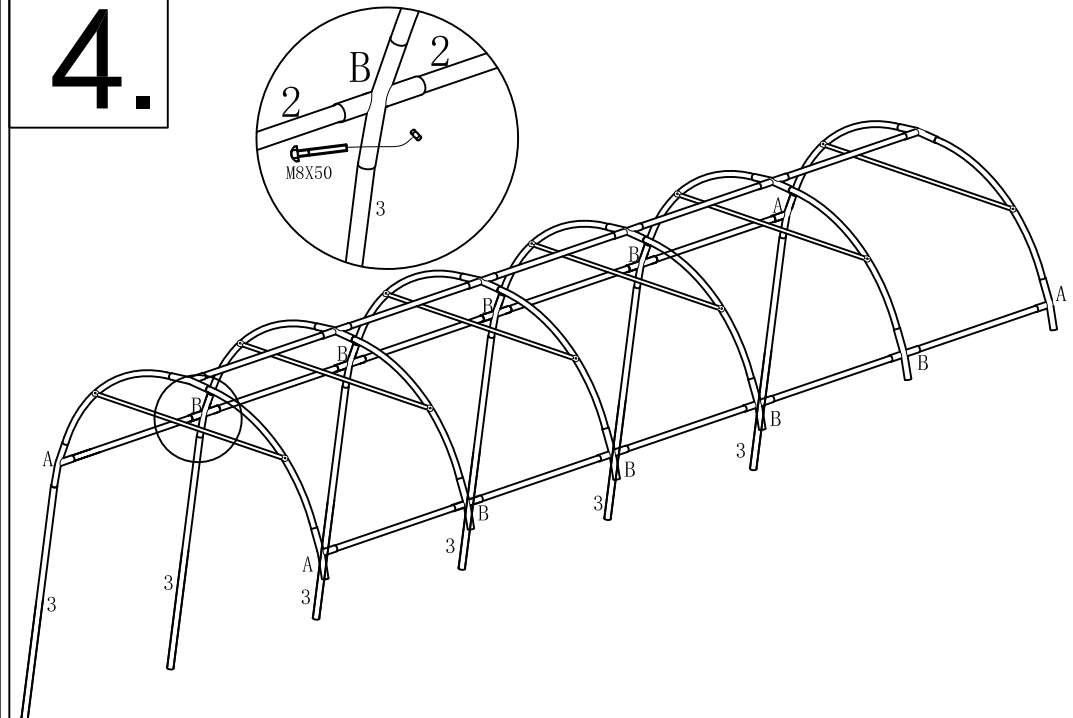

5.

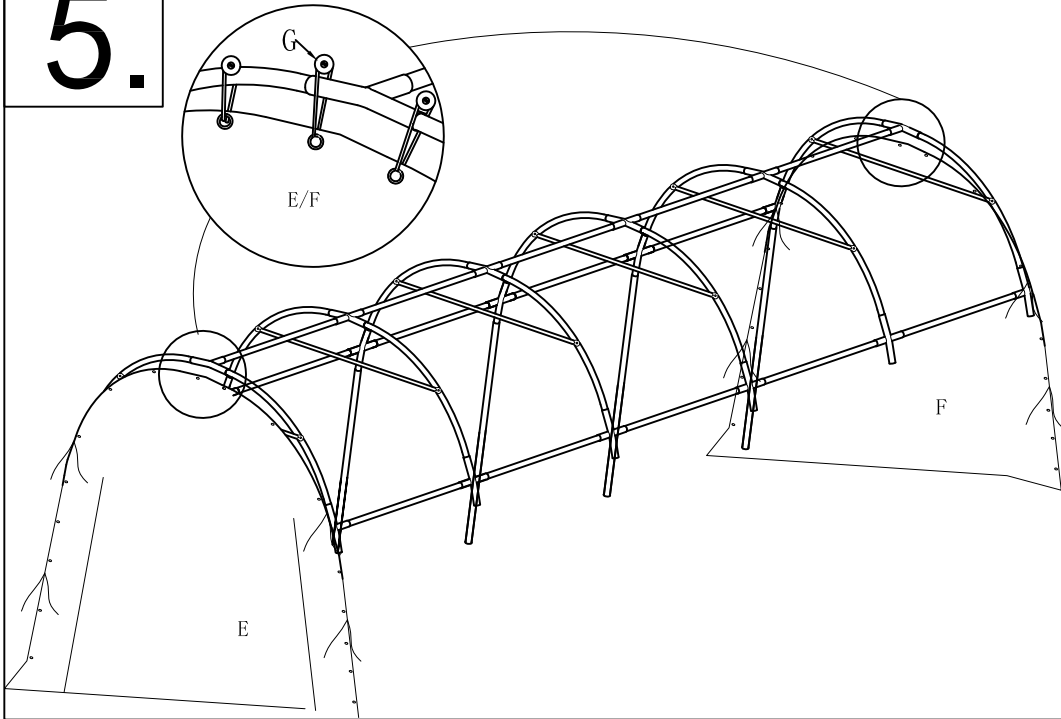

6.

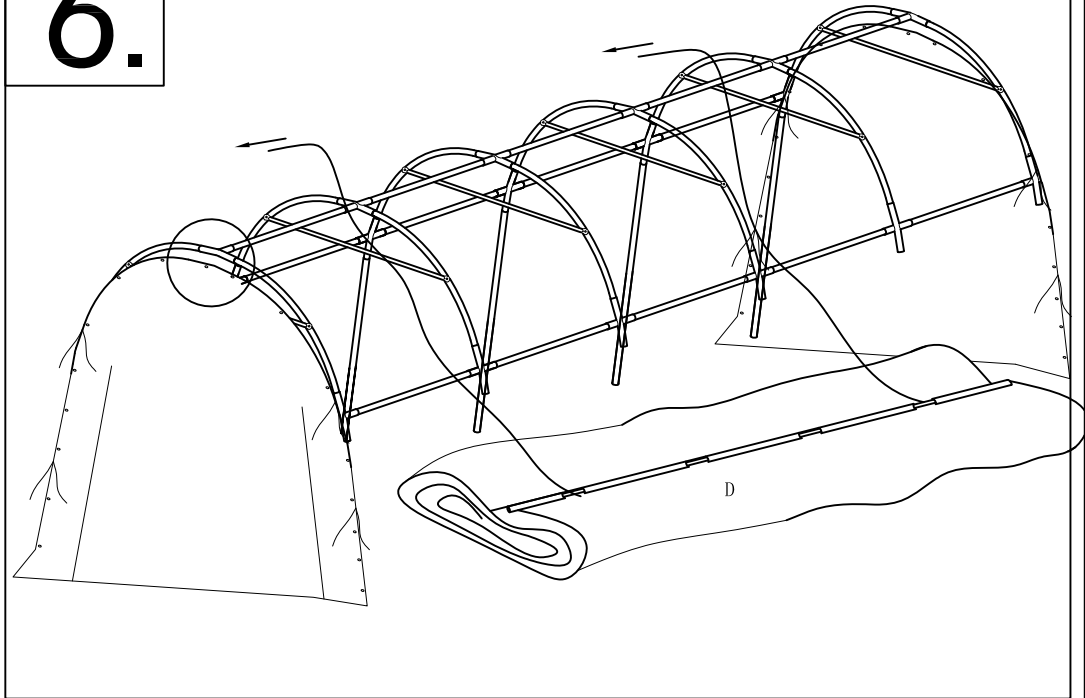

7.

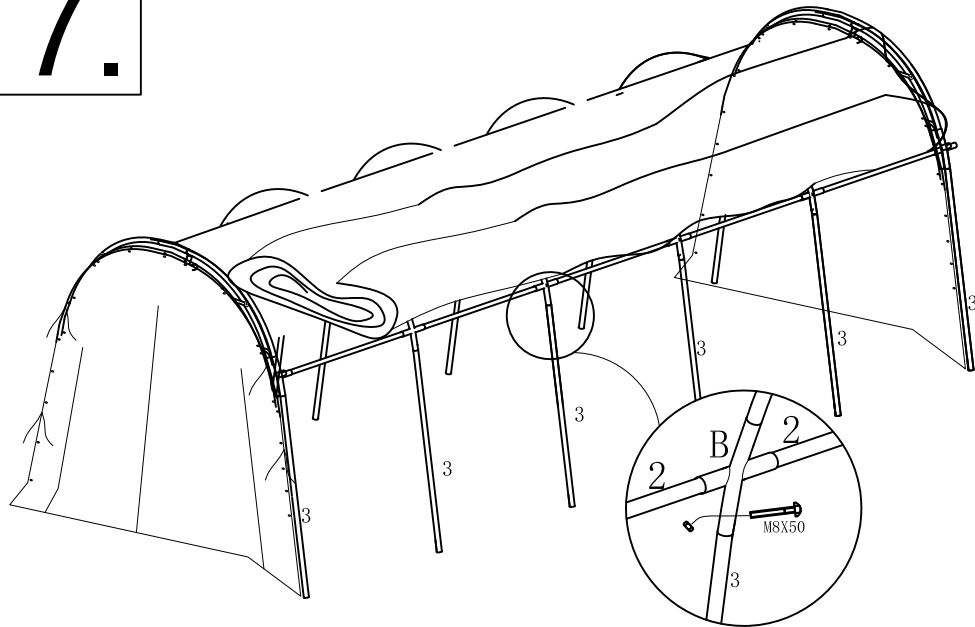

8.

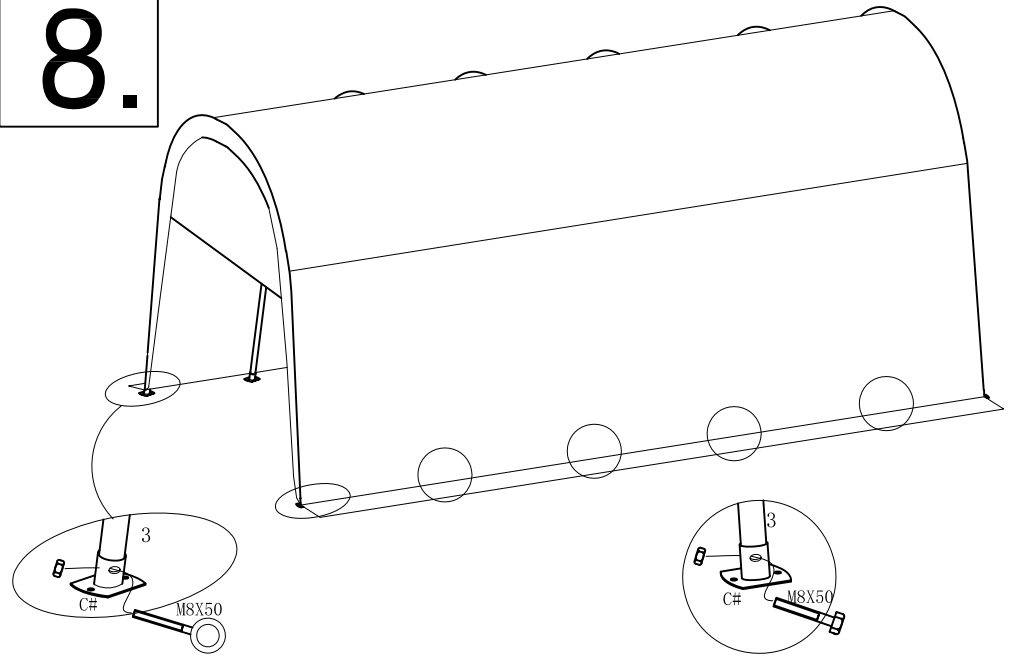

9.

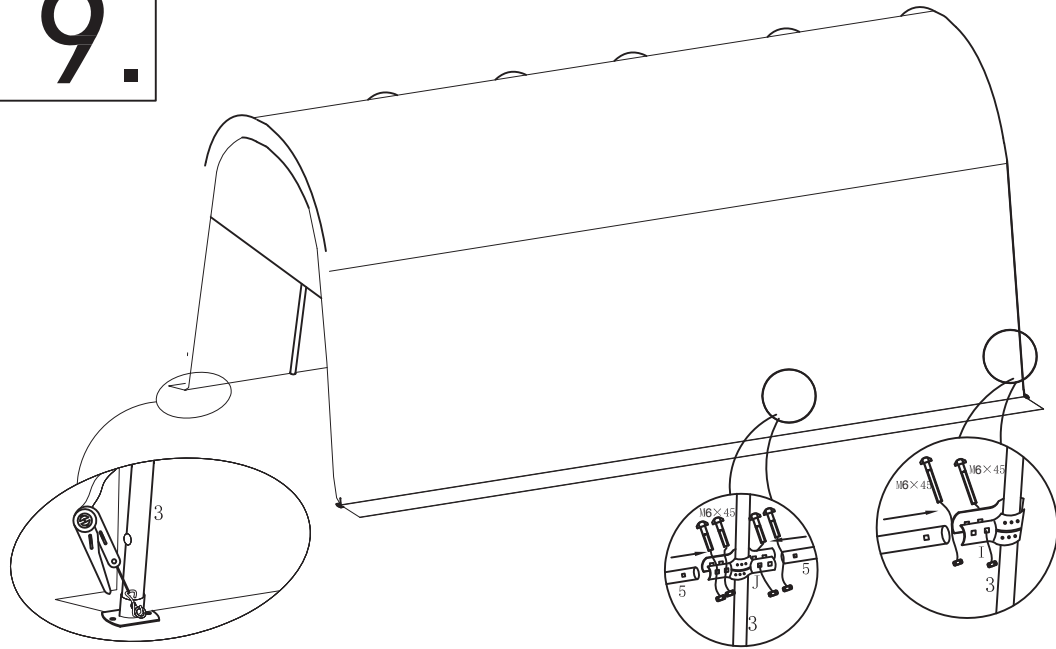

10.

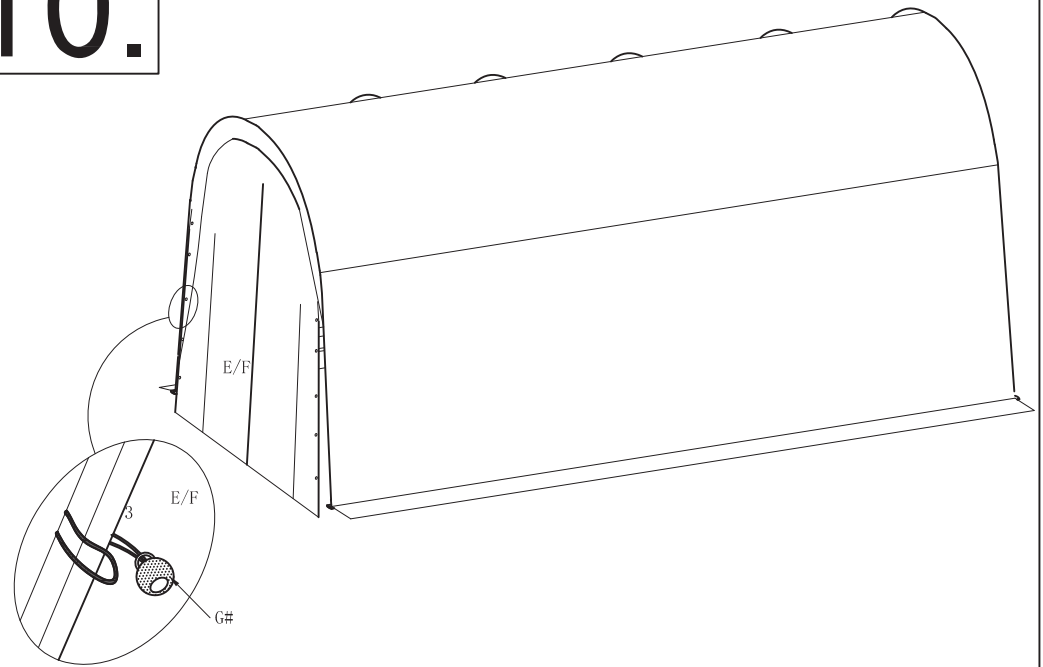

11.

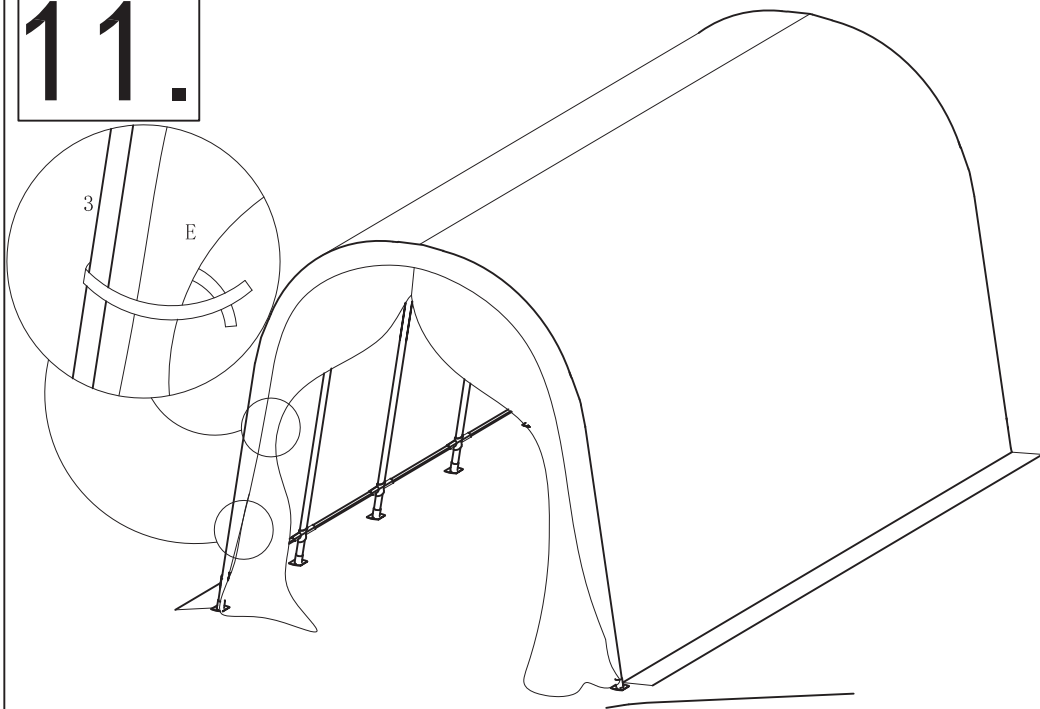

12.

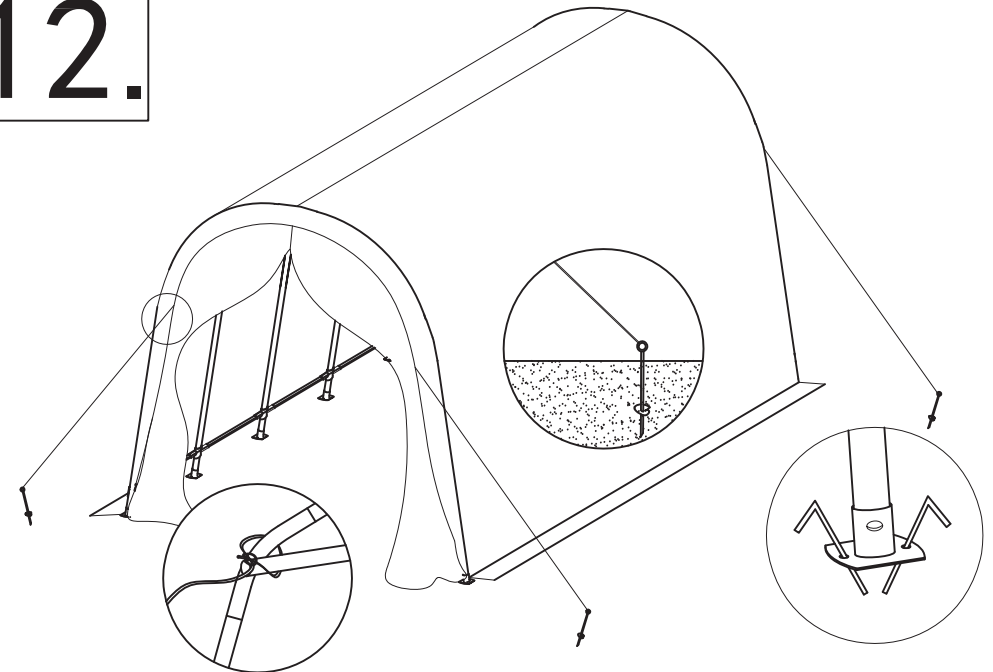

Securing Ratchet Tie-Downs

Note: Use these instructions in the pages that follow.

1. Thread the strap through the Ratchet's (8) spindle as far as it will go.

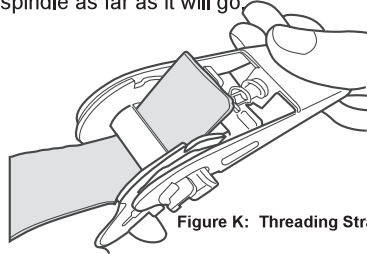

Figure K: Threading Strap through Spindle

2. Insert the S-hook of the Ratchet into the hole in the Corner Leg (6).

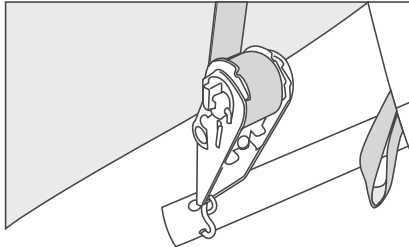

Figure L: Inserting Hook into Corner Leg

3. Lift and lower the Ratchet's handle to wind and tighten the strap onto the spindle.

Releasing Ratchet Tie-Downs

1. Depress the spring-loaded bar on the handle.
2. Open Ratchet handle completely.
3. Unwind the strap.

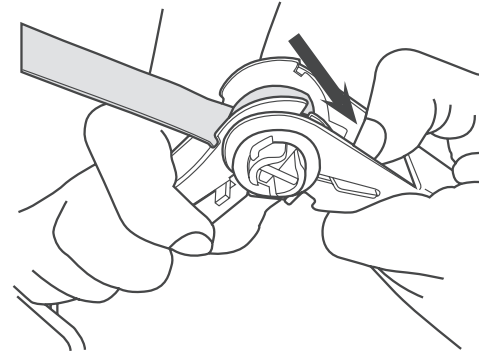

Figure N: Releasing Ratchet