

# HEADBOARD

Twin Size • King Size  
Post Kit







Examine all packaging material for small parts that may have come loose during shipment. Periodic checks are recommended to insure that all components are in proper position, tight and free from damage. Keep this assembly instruction for future reference. Adult assembly is required.

## HARDWARE LIST

- A (6) Medium Allen Bolts
- B (4) Metal Washers
- C (4) Rubber Washers
- D (4) Spring Washers
- E (4) Hex Nuts
- F (1) Allen Wrench
- G (4) Long Allen Bolts

## PARTS LIST

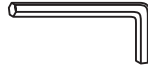
- H (1) Headboard
- I (1) Wood Posts

PART	QTY	HARDWARE	PART	QTY	HARDWARE
A	6		B	4	
C	4		D	4	
E	4		F	1	
G	4				

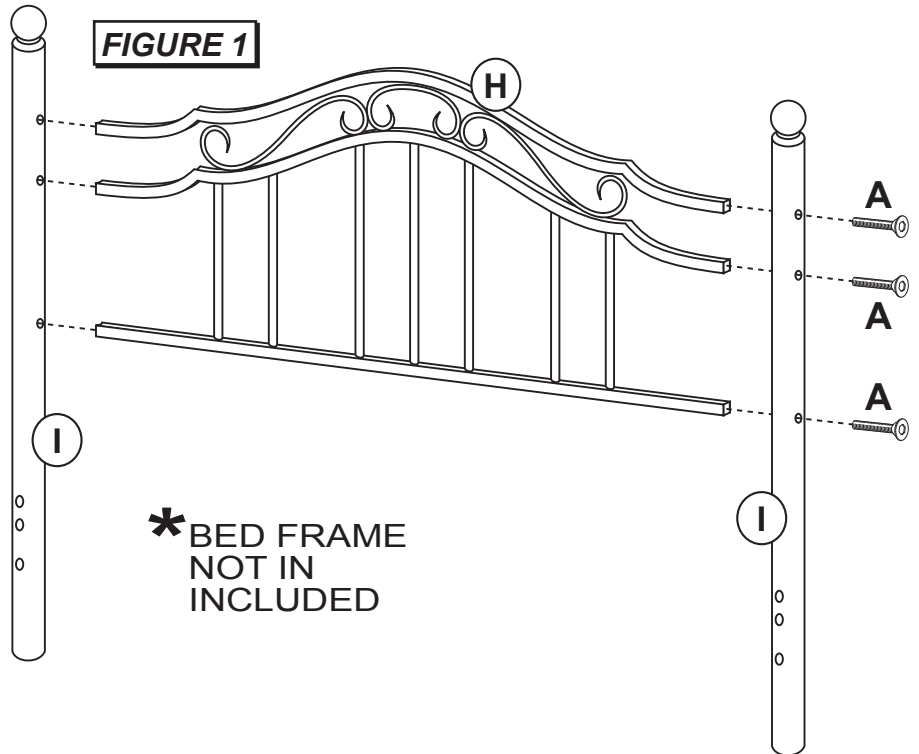
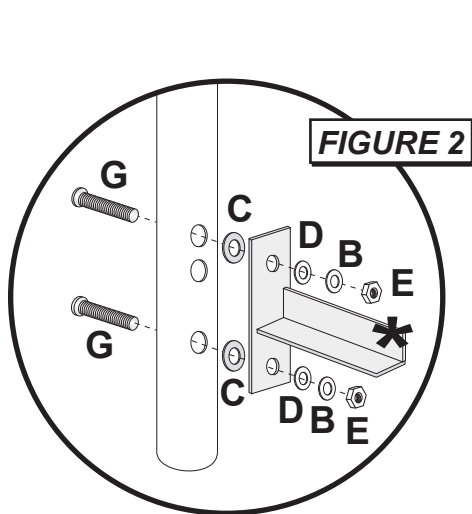

### STEP 1 - Figure 1

#### \*Assembling Duo Panels \*

Begin assembly by first attaching Headboard Panel (H) to both Wood Posts (I), using 3 Medium Allen Bolts (A) per each post. Tighten all bolts only using Allen Wrench (F) provided.

### STEP 2 - Figure 2

#### \*Assembling Bed Frame to Headboard \*

Attach Bed Frame (\*Not Included) to each Long Wood Post (I), using 2 Long Allen Bolts (G) from the back side, 2 Rubber Washers (C), 2 Metal Washers (B), 2 Spring Washers (D) & 2 Hex Nuts (E) per each post. Tighten all bolts only using Allen Wrench (F) provided. Assembly is now complete.

# TÊTE DE LIT

Double Taille • Roi Taille  
Tige Équipement







Examinez tous les matériaux d'emballage pour les petites pièces qui peuvent avoir été lâche pendant le transport. Des contrôles périodiques sont recommandées afin d'assurer que tous les composants sont en bonne position, tendu et sans dommages. Gardez ces instructions de montage pour référence future. Assemblage par un adulte est requise.

## LISTE DU MATÉRIEL

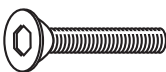
- A (6) Moyenne Boulons Allen
- B (4) Rondelles Métalliques
- C (4) Rondelles en Caoutchouc
- D (4) Rondelles
- E (4) Écrous Hexagonaux
- F (1) Clé Allen
- G (4) Long Boulons Allen

## LES PARTIES ENUMERENT

- H (1) Tête de Lit
- I (1) Tiges Bois

PART	QTY	HARDWARE	PART	QTY	HARDWARE
A	6		B	4	
C	4		D	4	
E	4		F	1	
G	4				

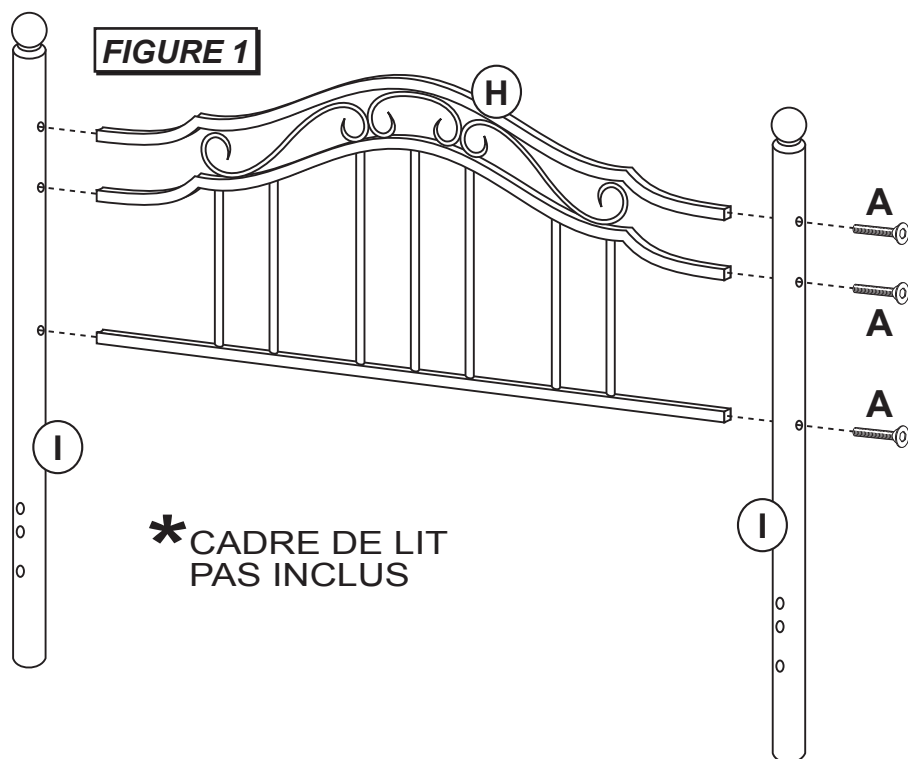
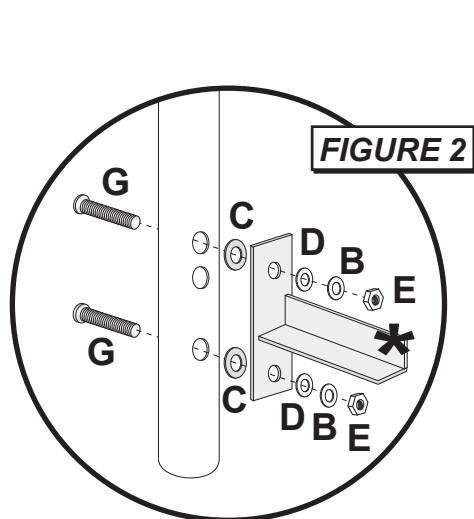

### ÉTAPE 1 - Figure 1

#### \* Assemblage de panneaux Duo \*

Commencez par assemblage premier panneau de chevet de fixation (H) aux deux poteaux de bois (B), avec 3 boulons Allen moyennes (A) pour chaque poste. Serrez tous les boulons en utilisant uniquement la clé Allen (F) fourni.

### ÉTAPE 2 - Figure 2

#### \* Assemblage de cadre de lit à tête de lit \*

Fixez Cadre de lit (\* non inclus) pour chaque long bois Post (I), en utilisant 2 boulons Allen longues (G) de la face arrière, 2 rondelles en caoutchouc (C), 2 rondelles métalliques (B), 2 rondelles à ressort (D) et 2 écrous (E) par chaque poste. Serrez tous les boulons en utilisant uniquement la clé Allen (F) fourni. Le montage est maintenant terminé.