

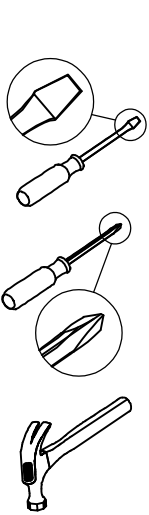

**ASSEMBLY INSTRUCTION**

**ADULT ASSEMBLY REQUIRED**

# Before You Start



Read through each step carefully and follow the proper order

Separate and count all your parts and hardware

Give yourself enough room for the assembly process

Have the following tools: Flat Head Screwdriver, #2 Phillips Head Screwdriver and Hammer

Caution: If using a power drill or power screwdriver for screwing, please be aware to slow down and stop when screw is tight. Failure to do so may result in stripping the screw.

# Cam Lock Fastening System

This Cam Lock Fastening System will be used throughout the assembly process.

1

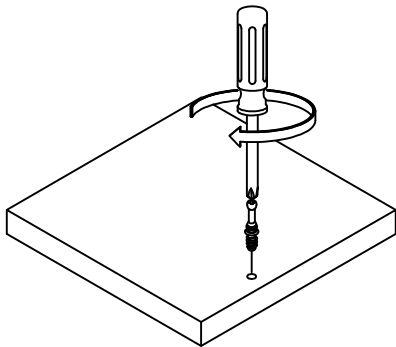

2

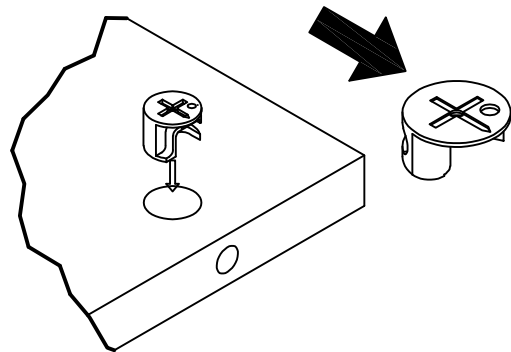

3

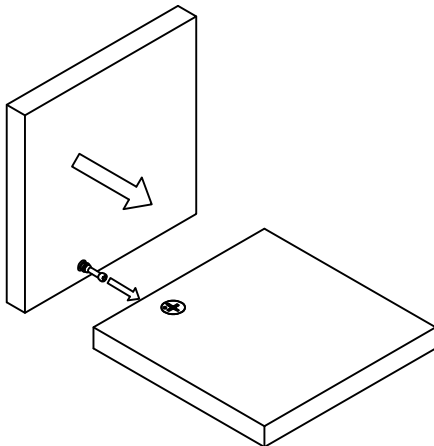

4

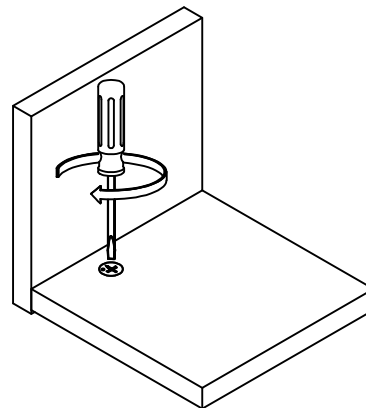

# Parts Identification

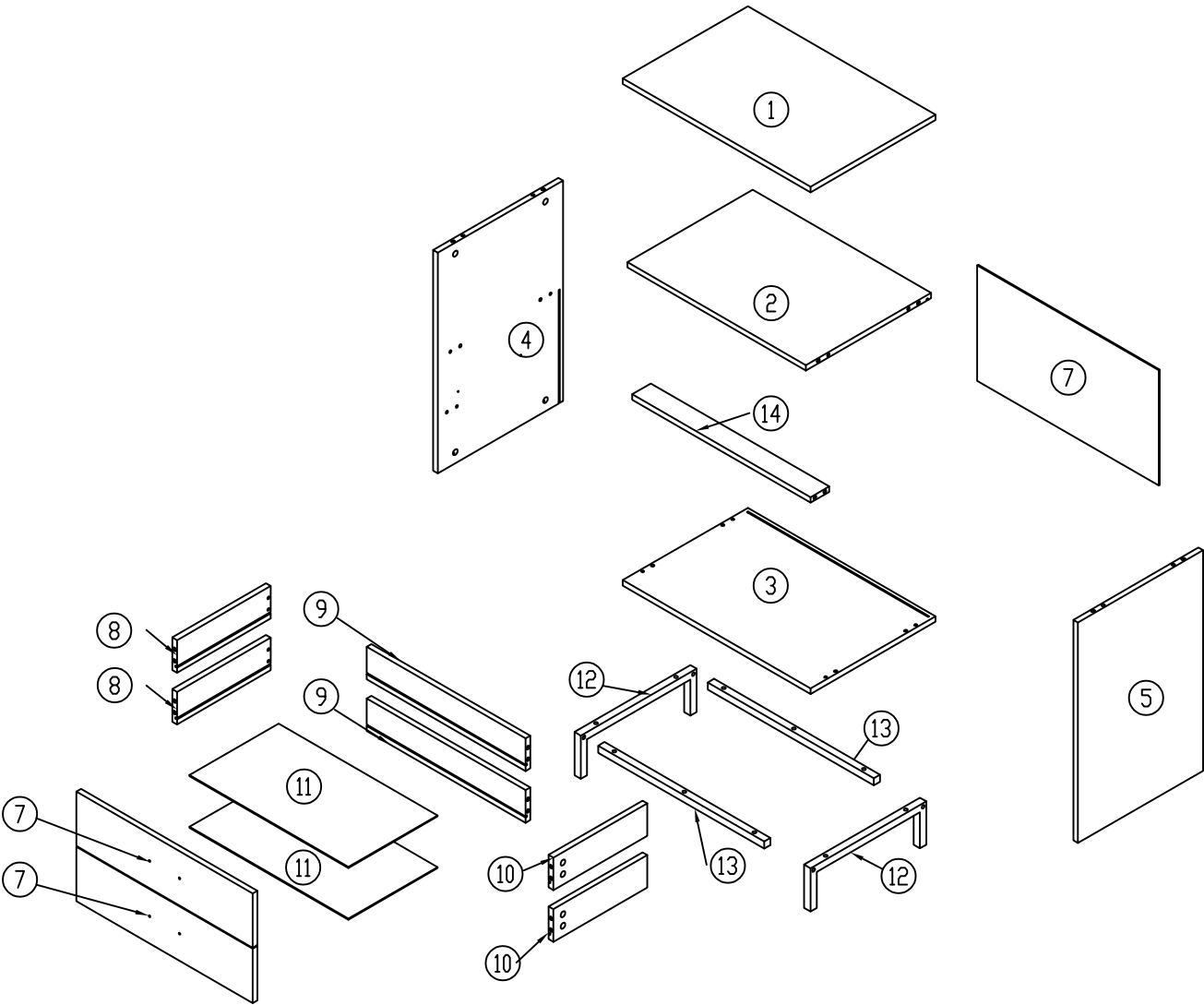

# Hardware Identification

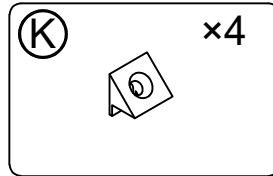
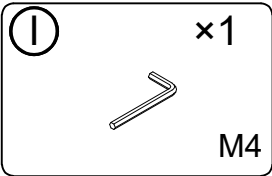
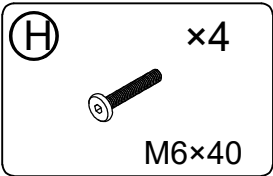
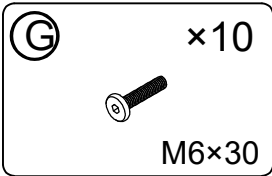
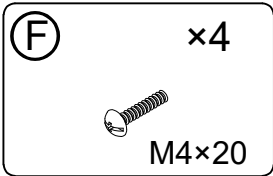
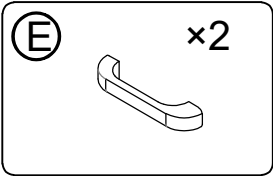
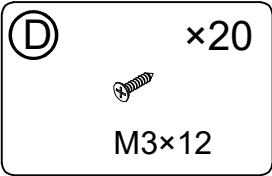
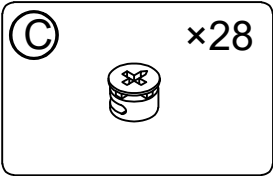
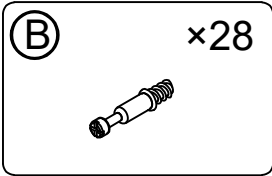
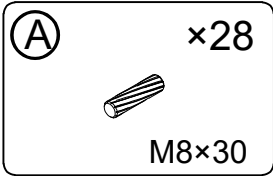

Not Actual Size

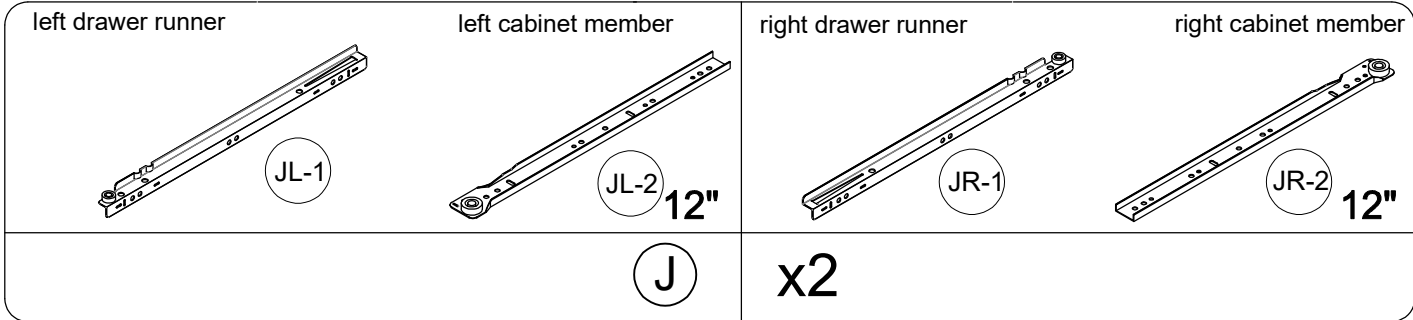

# Parts 1

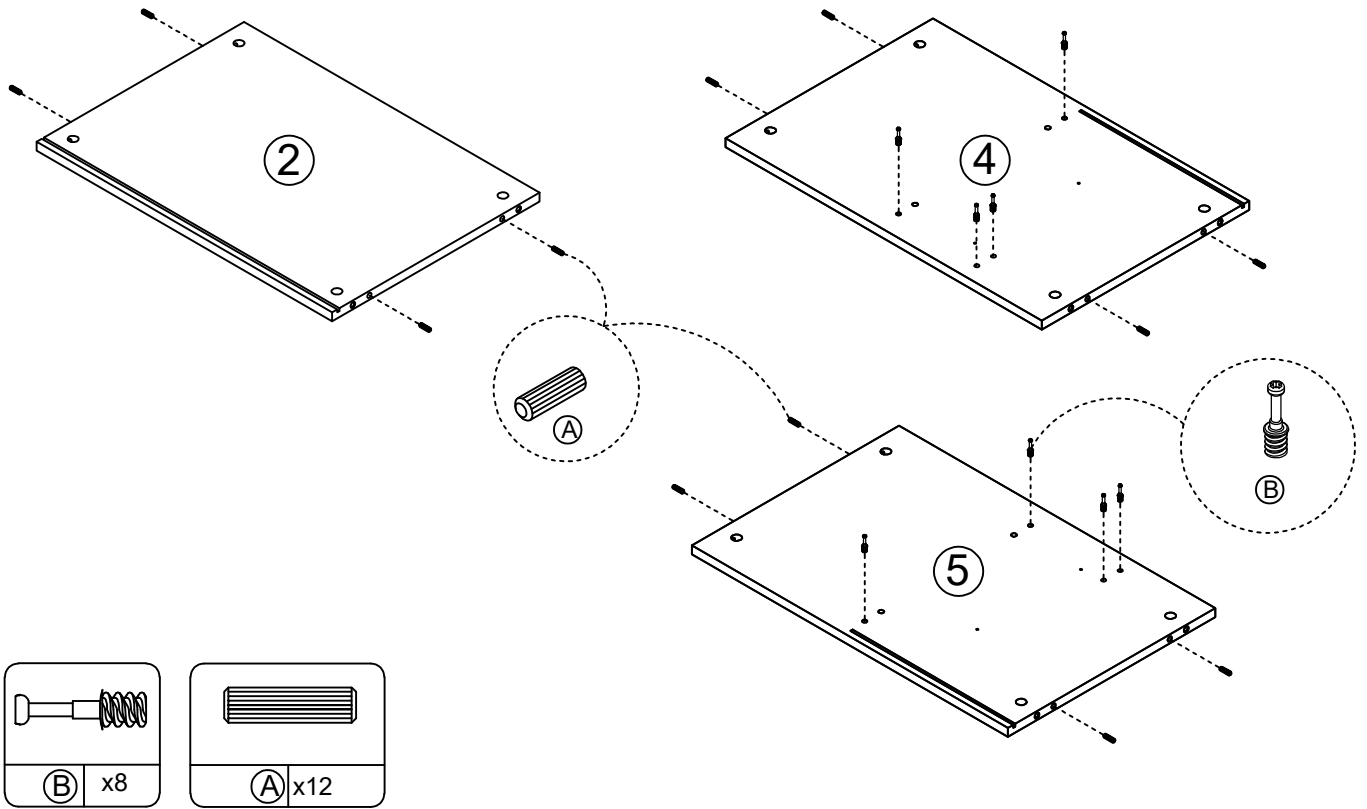
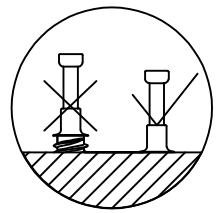

# Parts 2

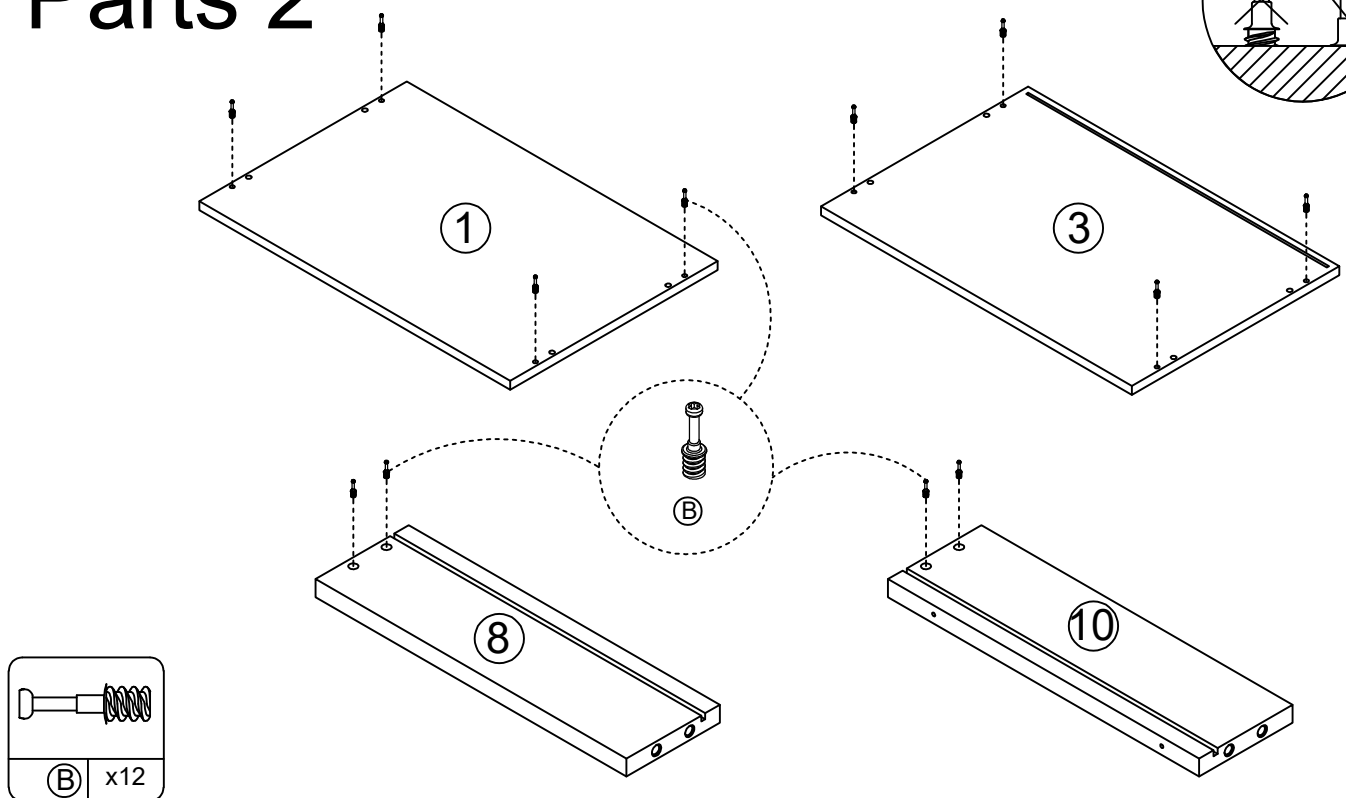
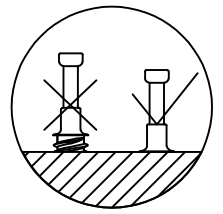

# Parts 3

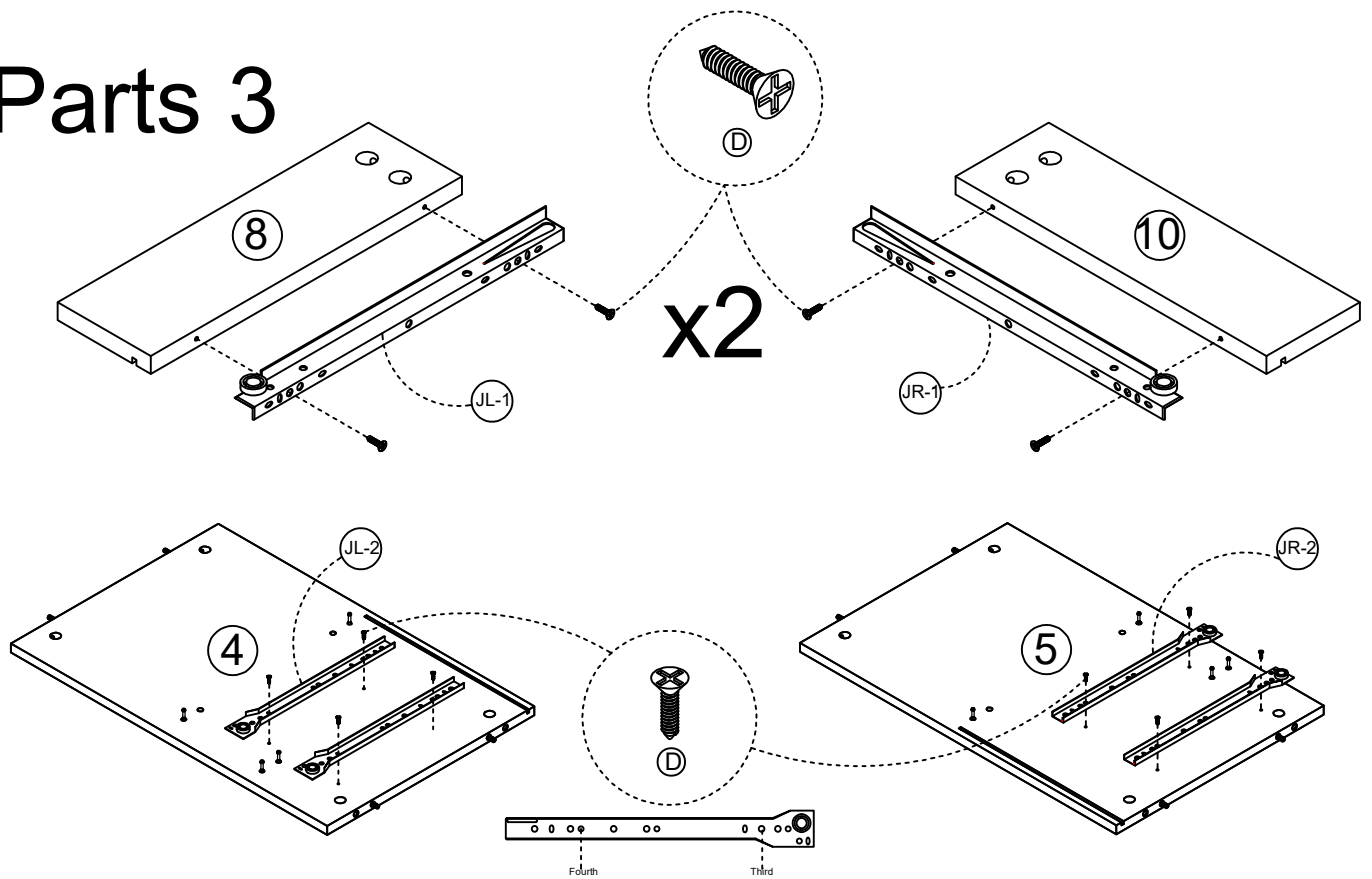

(D) x16		12"		12"
	(J) x2			

# Parts 4

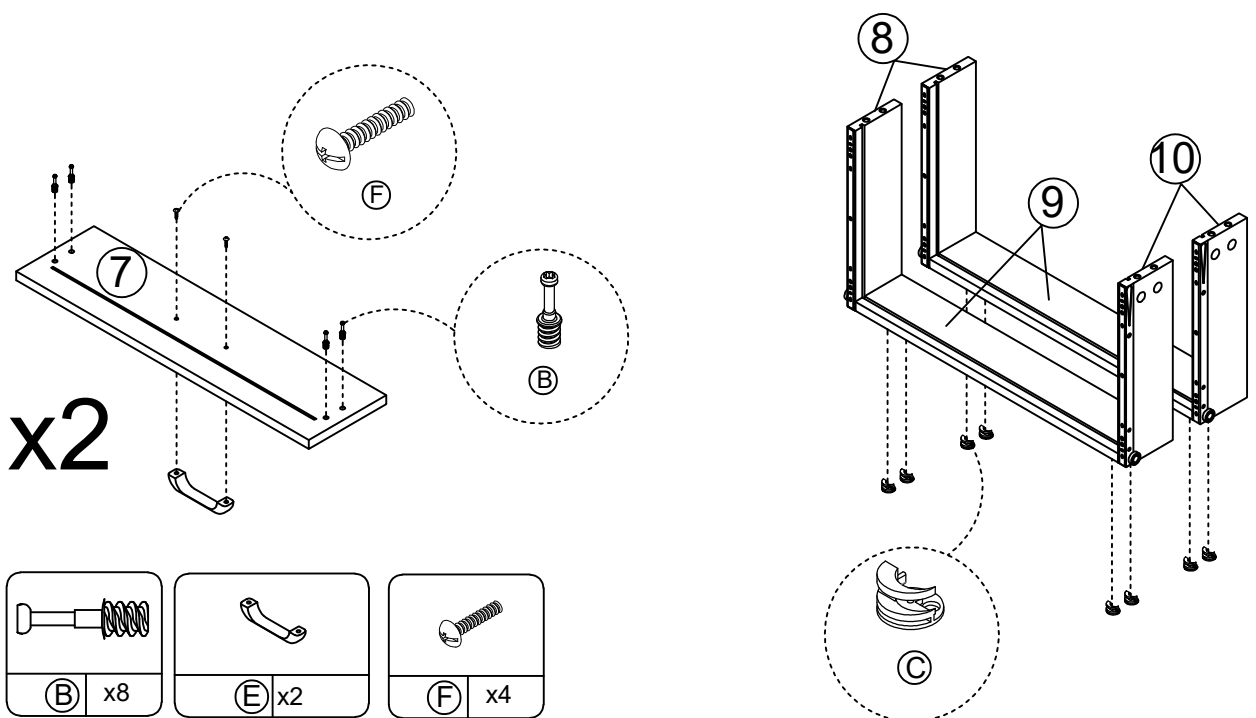
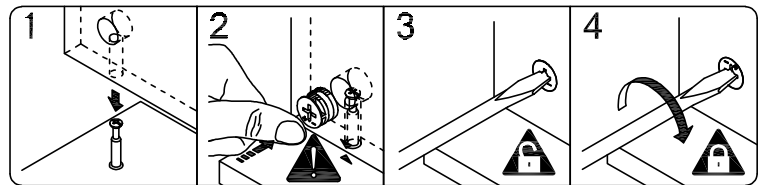

(C) x4	(B) x8	(E) x2	(F) x4

# Parts 5

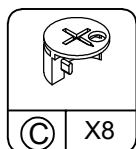
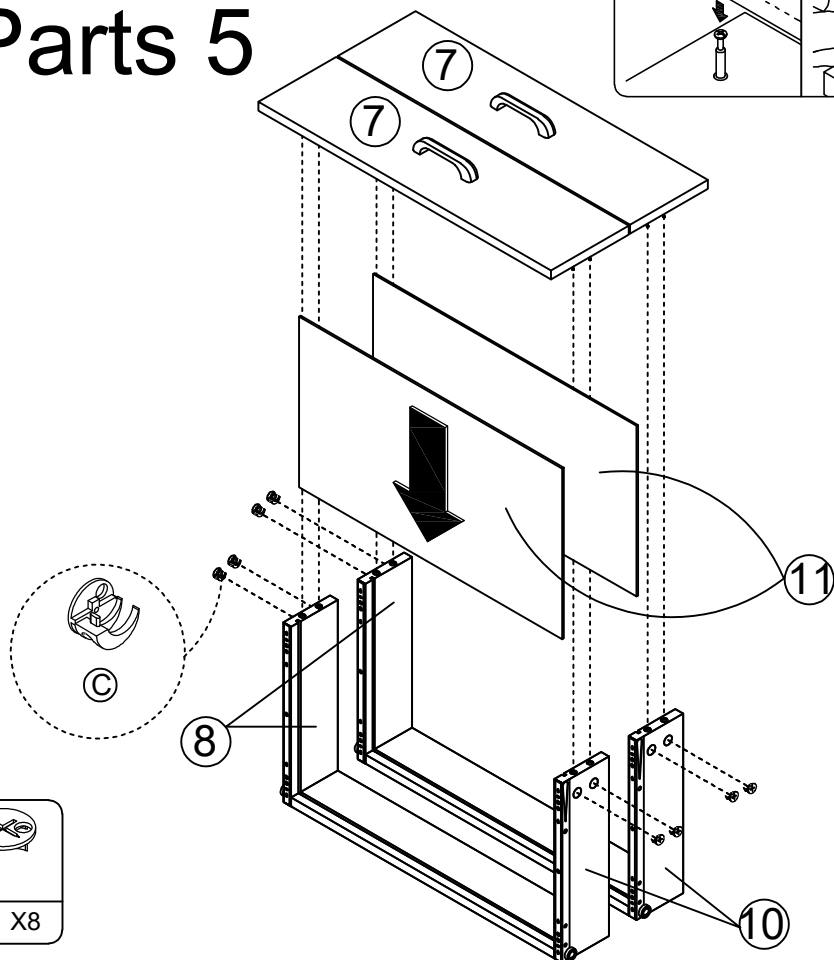
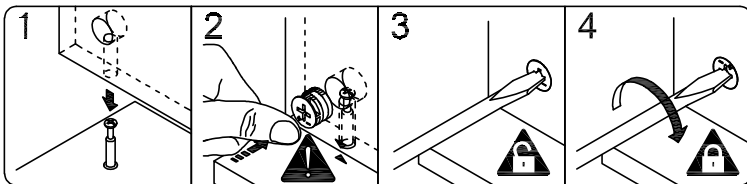

# Parts 6

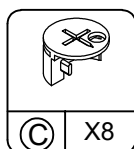
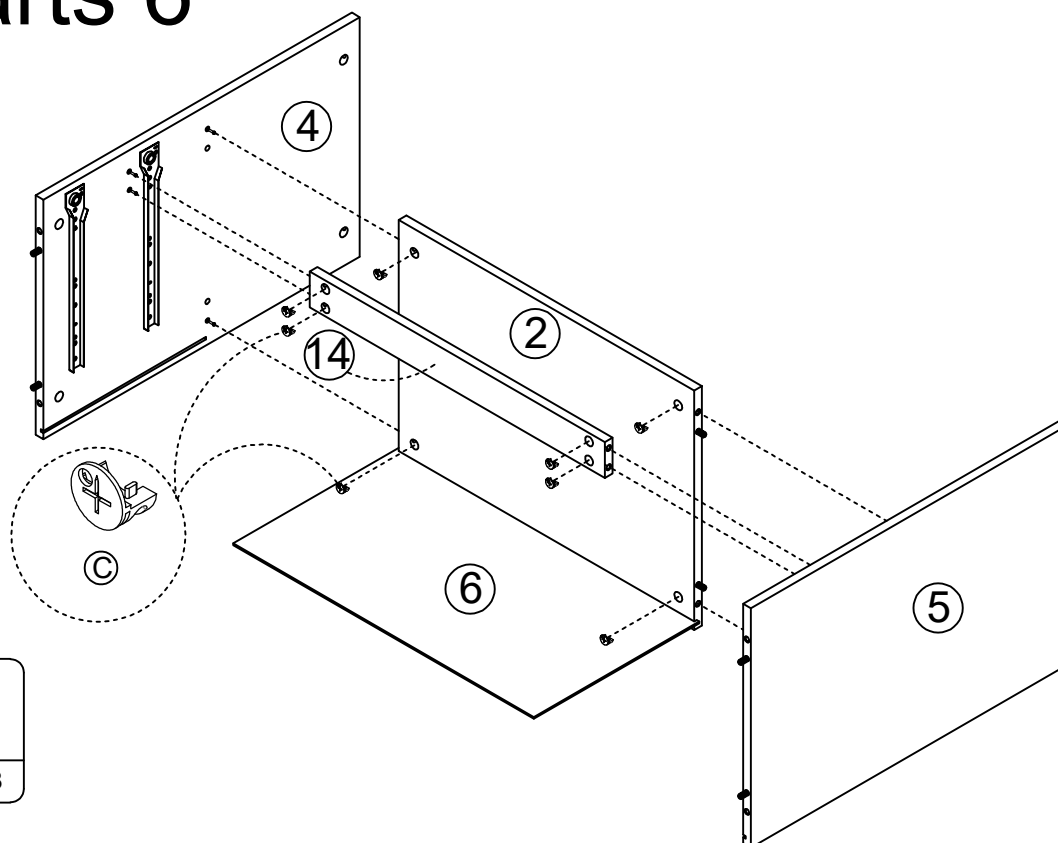

# Parts 7

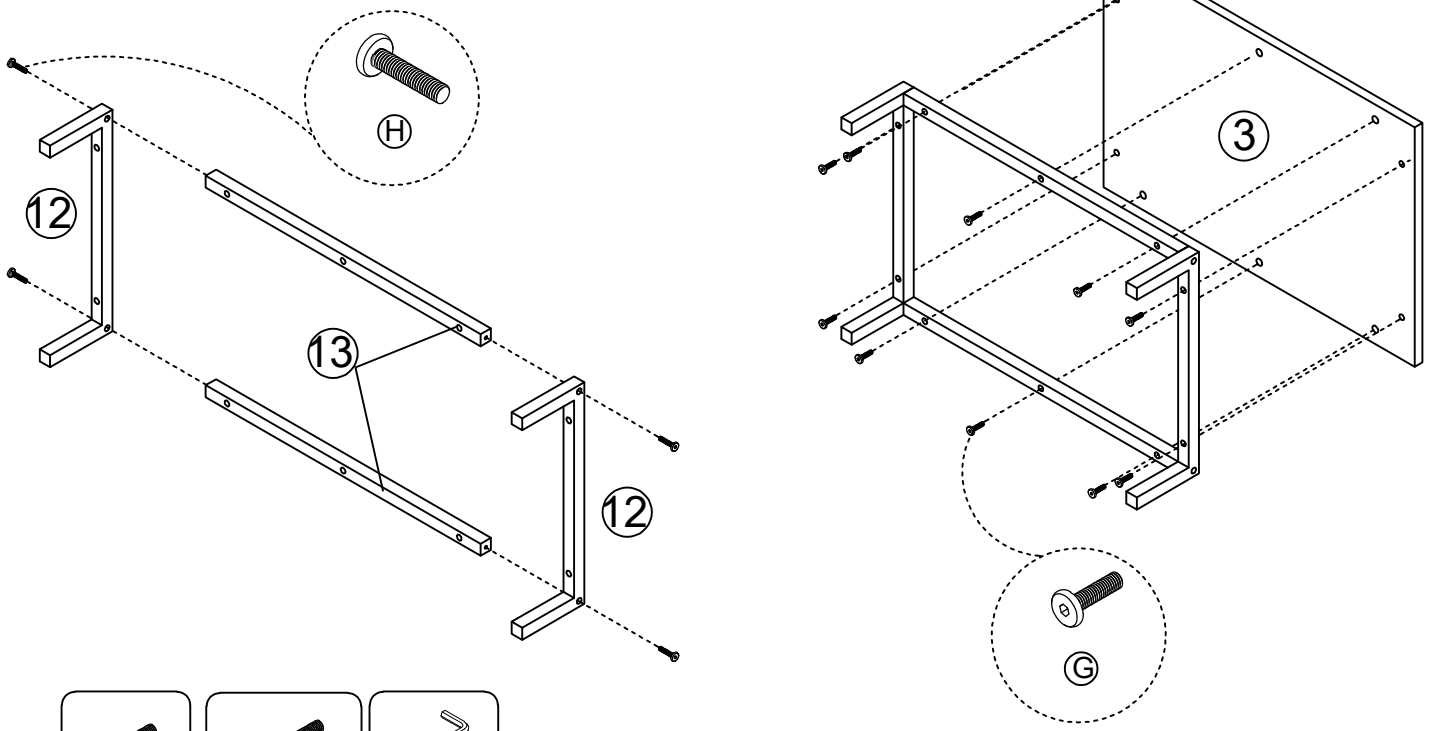

- |  |     |  |    |  |    |
|--|-----|--|----|--|----|
|  | X10 |  | x4 |  | X1 |
|--|-----|--|----|--|----|

# Parts 8

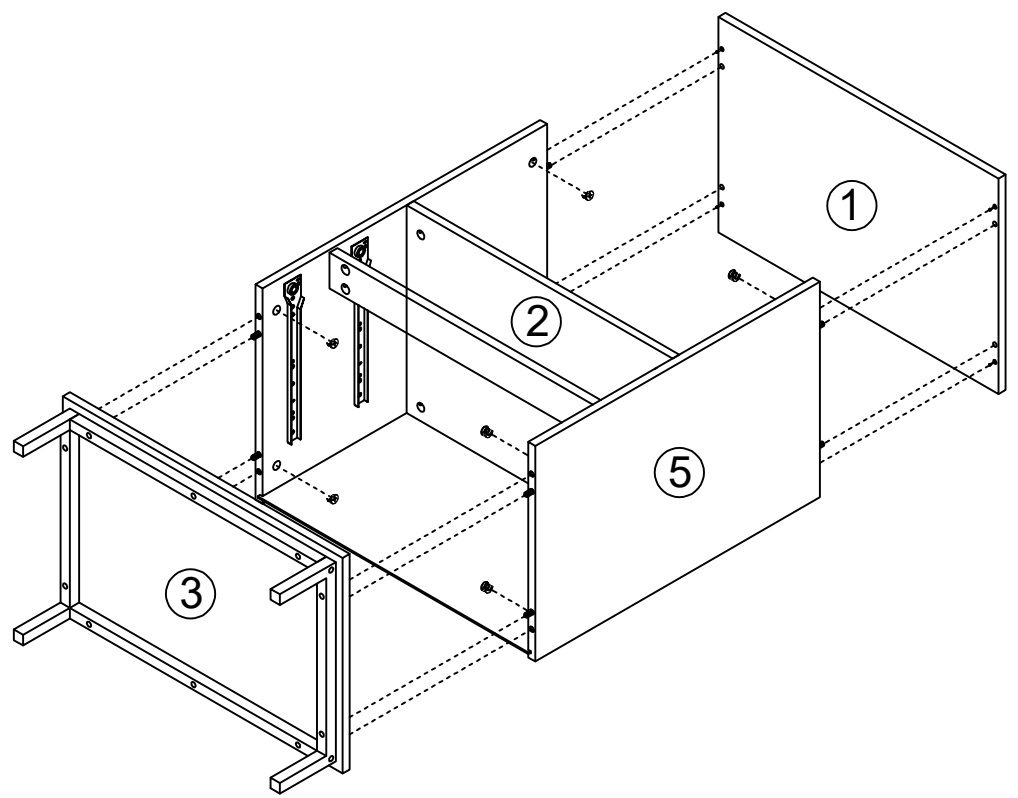
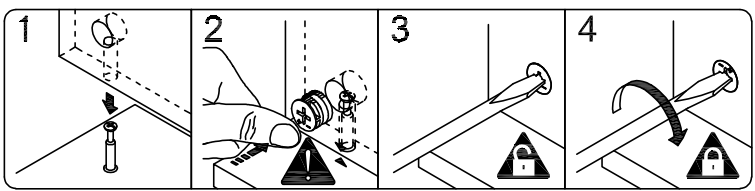

- |  |    |
|--|----|
|  | X8 |
|--|----|

# Parts 9

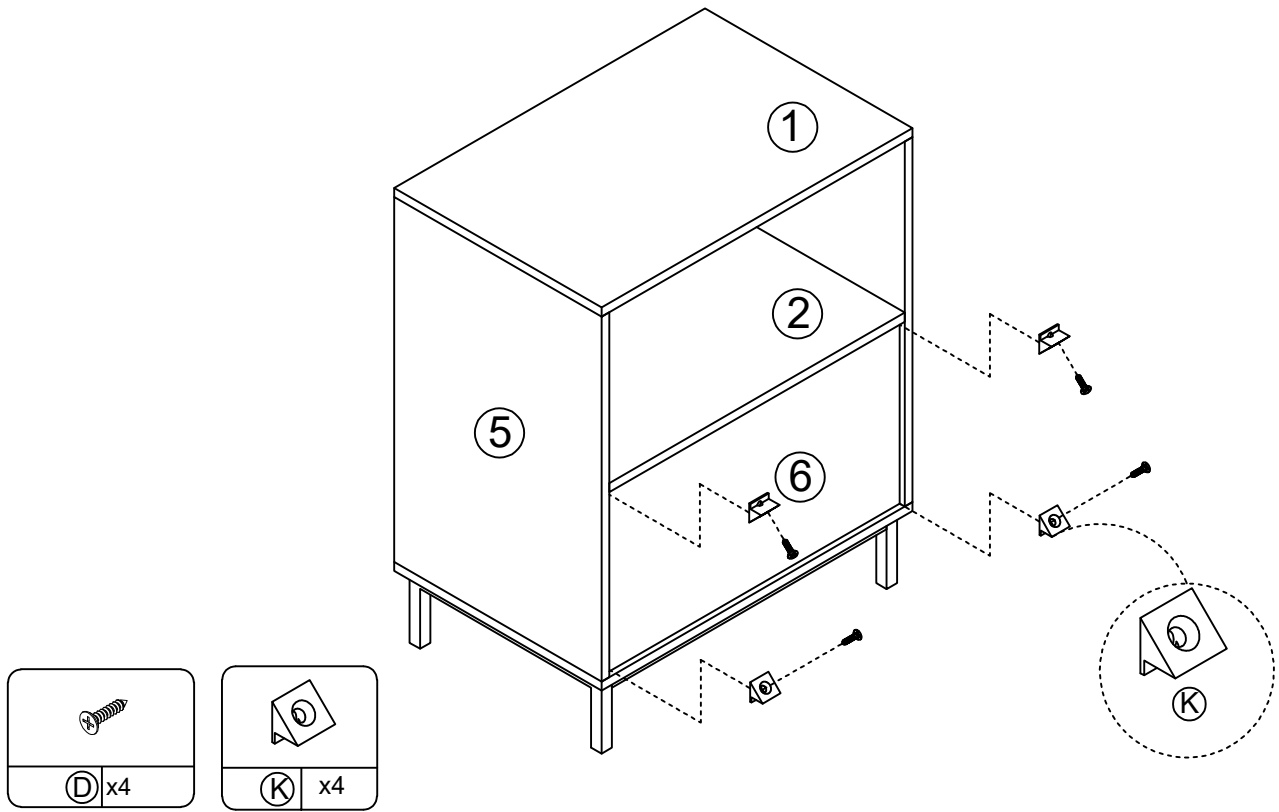

# Parts 10

