





ASSEMBLY INSTRUCTIONS

HARDWARE LIST

NO.	Sketch	Description	Qty
1		Bolt(1/4"*7/8")	10 PCS
2		Bolt(1/4"*1-1/4")	8 PCS
3		Spring Washer(1/4")	18PCS
4		Washer(1/4")	18 PCS
5		Allen wrench(4mm)	1 PC

PARTS LIST

NO.	Sketch	Description	Qty
A		Table top	1 PC
B		Wing Panel	2 PCS
C		Pedestal	2 PCS
D		Base Ring	1 PC

Step 1

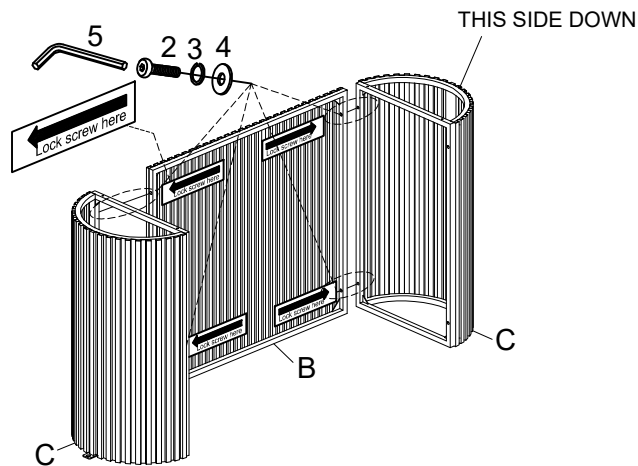

Note: At this stage, do not fully tighten the bolts .

Step 2

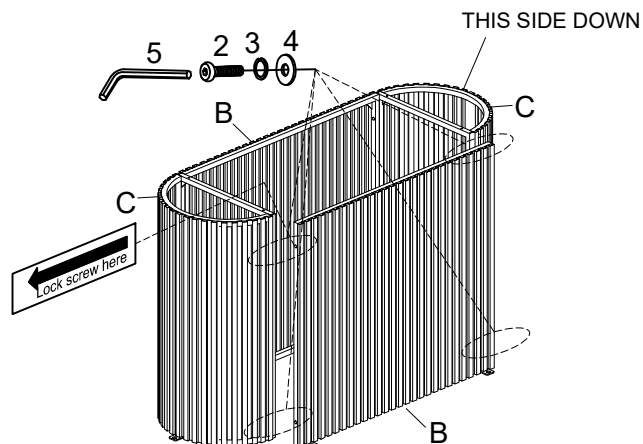

Note: At this stage, do not fully tighten the bolts .

ASSEMBLY INSTRUCTIONS

Step 3

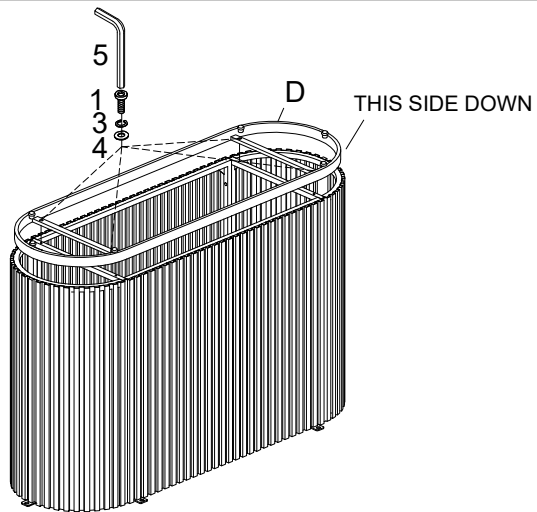

Note: At this stage, tighten all screws on the base and flip the base over so that the metal frame sits underneath.

Step 4 Attention: Place the table base as shown picture. With assistance from your adult partner, hold up the Table top (A) to the Base.
Attention: When locking the desktop, please use Short Bolt(1).

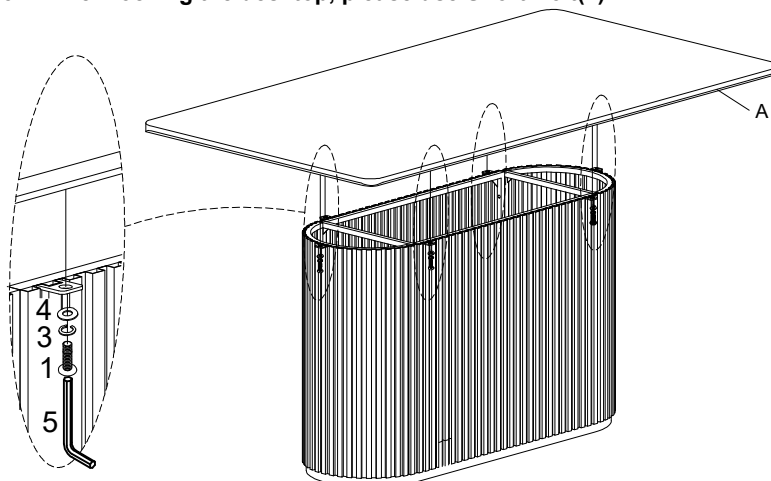

Note: At this stage, do not fully tighten the bolts .



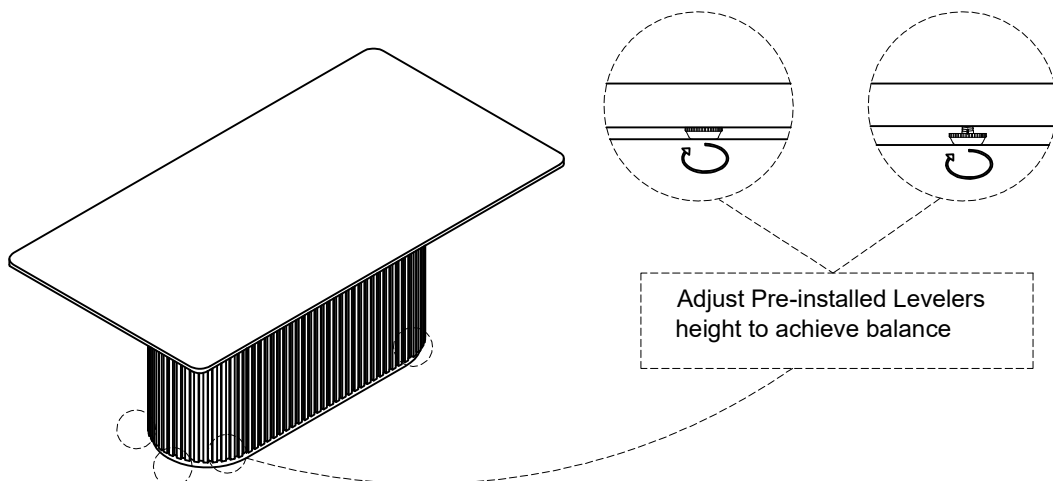



Step 5





Note: Fully tighten all bolts at this step.

ASSEMBLY INSTRUCTIONS

HARDWARE LIST

NO.	SKETCH	DESCRIPTION	QTY
A		Bolt(5/32" x 5/32")	4 PCS
B		Bolt(1/4" x 2-1/8")	4 PCS
C		Spring Washer(1/4")	4 PCS
D		Washer(1/4")	4 PCS
E		Allen Wrench(4mm)	1 PC
F		Allen Wrench(2mm)	1 PC

PARTS LIST

NO.	SKETCH	DESCRIPTION	QTY
1		Seat	1 PC
2		Backrest	1 PC
3		Metal frame	1 PC

Step 1

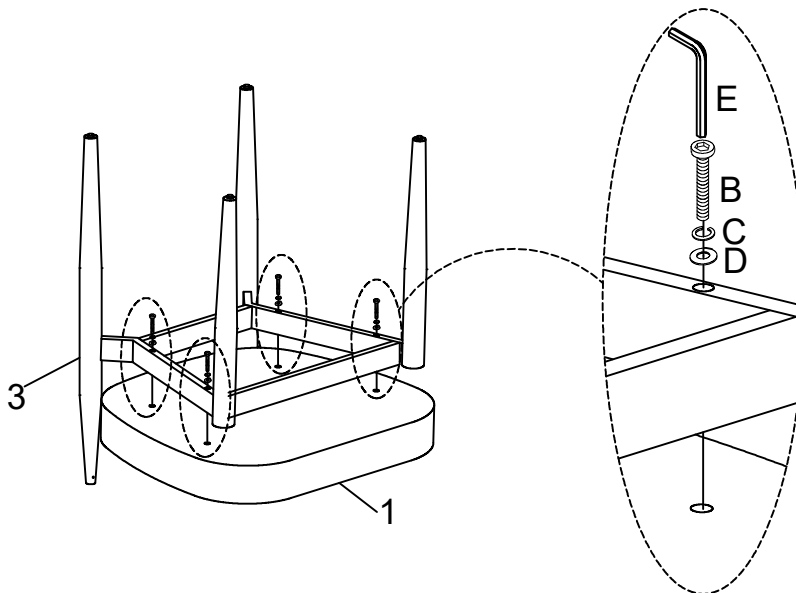

ASSEMBLY INSTRUCTIONS

Step 2

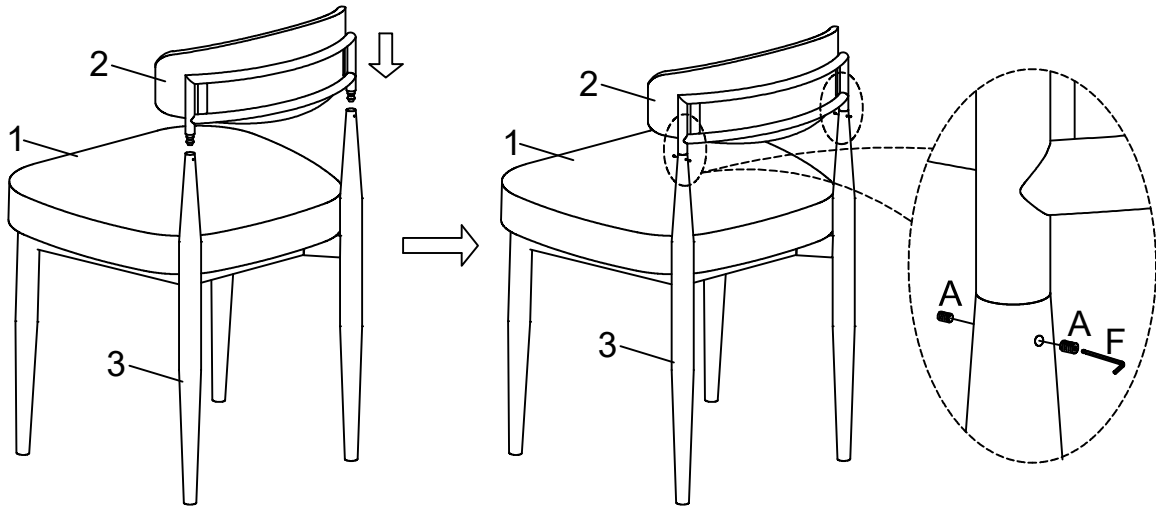

Step 3

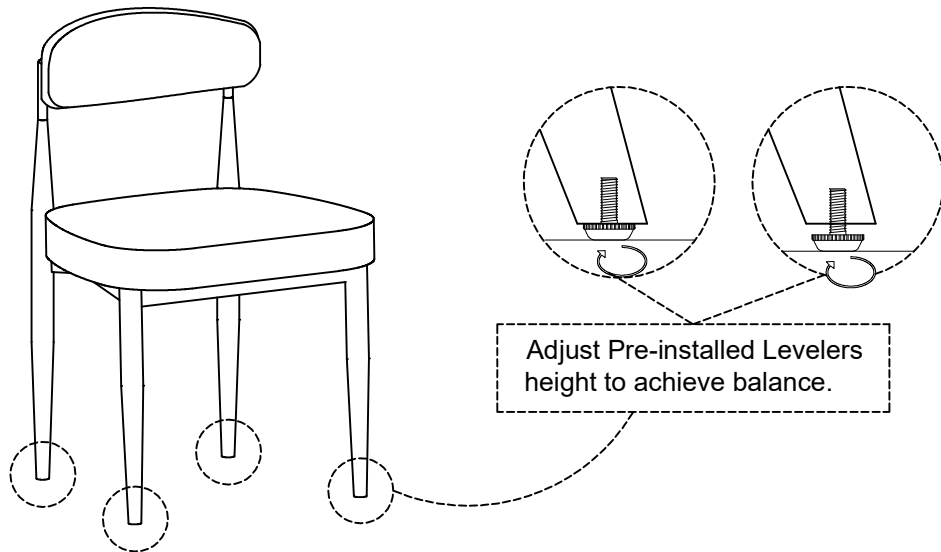

Step 4

