

NOTICE

*Please make sure that you have all part indicated and they are in good condition before you begin assembly of this item. Refer to part list and hardware list below for guidance.

*This item should be assembled on a soft surface to prevent scratching the finish during assembly.

*This item may require periodic tightening.

*If you are having difficulty, our friendly Customer Care team is always here to help. Please email customersupport@safavieh.com

PREPARATION

*Before beginning assembly of product, make sure all part are present. Compare part with part contents list and hardware contents list.

*If any part is missing or damaged, do not attempt to assemble the product.

*Estimated Assembly Time: 60 minutes.

*Tools Required for Assembly (included): Screwdriver

CARE AND MAINTENANCE

Adhesive felt pads should always be applied to areas of furniture which make direct contact with flooring, said application will prevent damage to the furniture and or surfaces on which the furniture lies. Objects placed on articles of furniture should rest on non abrasive material as to prevent damage to the wood finish. Objects whose composition consists of plastic and rubber are known to discolor and damage the wood surfaces on which they rest. Wipe up spills immediately and avoid common hazards such as hot dishes, harsh solvents and abrasives. Cleaning should be done with a soft lint free cotton cloth dampened with water or furniture polish. On highly used surfaces we recommend applying a quality paste wax which should be used on a regular basis to provide additional protection from scratches and spills. How often you apply the wax depends on how much wear the furniture receives.

Part List

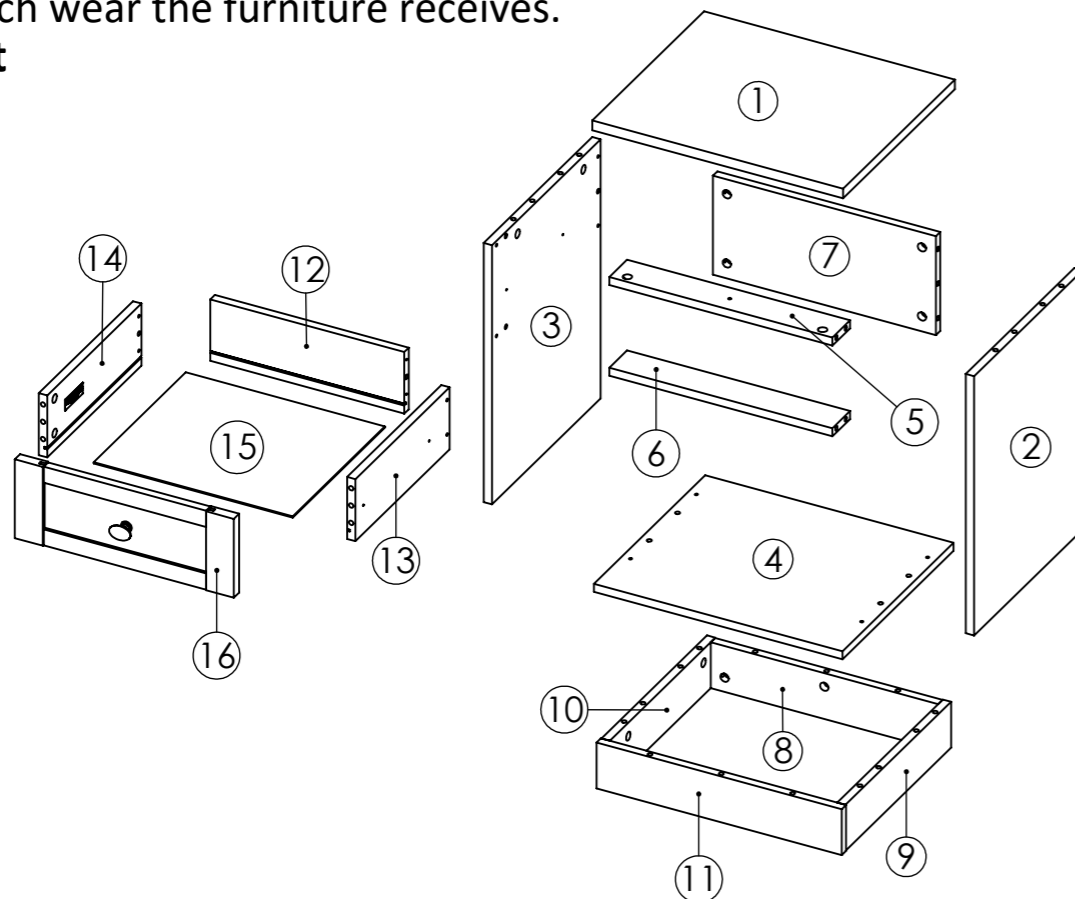

 **SAFAVIEH**
FURNITURE

Model#ACC3100

Product Dimensions: W 17.72" x D 14.96" x H 23.74"

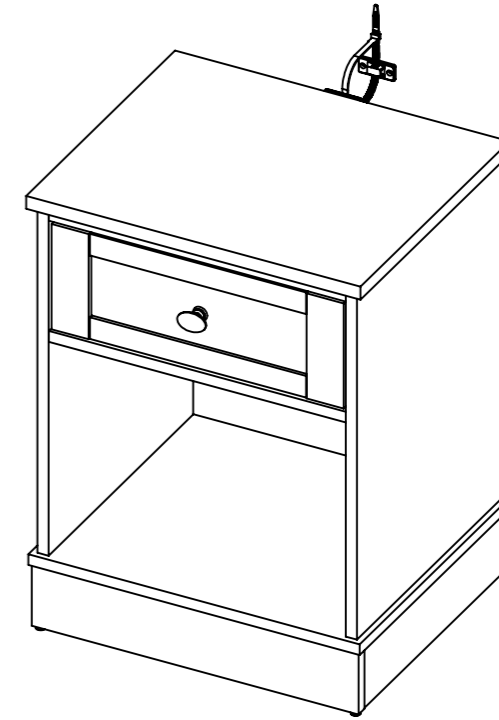

WARNING

TOTAL WEIGHT CAPACITY: 41 LBS

Top Load Capacity: 18 lbs







Drawer Load Capacity: 6 lbs

Shelf Load Capacity: 17 lbs

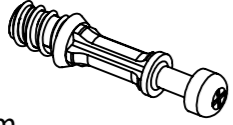
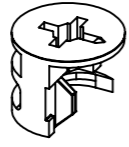
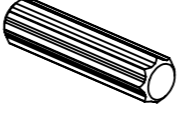
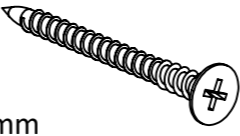
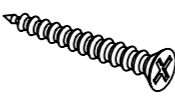
Warning: Do not stand on night stand

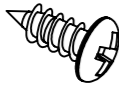
Warning: Do not over torque bolt

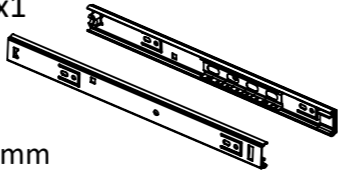
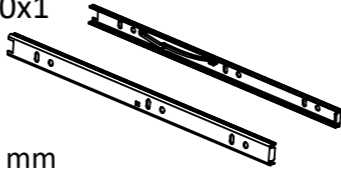
Hardware List

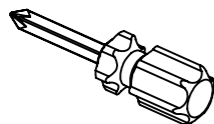
<p>HW1x26</p>  <p>Ø6x32 mm</p>	<p>HW2x26</p>  <p>Ø15x12 mm</p>	<p>HW3x30</p>  <p>Ø8x32 mm</p>	<p>HW4x4</p>  <p>Ø6x50 mm</p>	<p>HW5x4</p>  <p>Ø7x32 mm</p>	<p>HW6x1</p>  <p>Ø6x25 mm</p>
<p>HW7x8</p>  <p>Ø6x12 mm</p>	<p>HW8x1</p>  <p>Ø4x10 mm</p>	<p>HW9x1</p>  <p>Ø300 mm</p>	<p>HW10x1</p>  <p>Ø300 mm</p>	<p>HW11x1</p>  <p>31x35 mm</p>	<p>HW12x11</p>  <p>Ø20 mm</p>
<p>HW13x1</p>  <p>90 mm</p>					

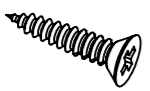
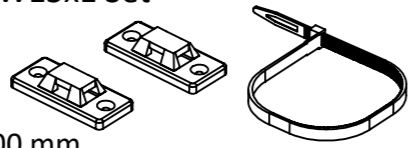
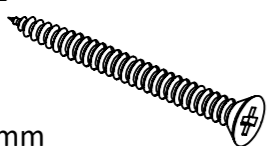
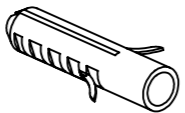
<p>Anti-tip restrain pack</p>	
<p>HW14x2</p>  <p>Ø6x15 mm</p>	<p>HW15x1 Set</p>  <p>300 mm</p>
<p>HW16x2</p>  <p>Ø10x50 mm</p>	<p>HW17x2</p>  <p>Ø8x35 mm</p>

Part List & HW

Piece	Description	Qty	Carton Call
1	Top Panel	1	1 of 1
2	Side Panel - Right	1	1 of 1
3	Side Panel - Left	1	1 of 1
4	Bottom Panel	1	1 of 1
5	Upper Apron	1	1 of 1
6	Lower Apron	1	1 of 1
7	Back Panel	1	1 of 1
8	Plint - Rear	1	1 of 1
9	Plint - Right	1	1 of 1
10	Plint - Left	1	1 of 1
11	Plint - Front	1	1 of 1
12	Drawer Back	1	1 of 1
13	Drawer Side - Right	1	1 of 1
14	Drawer Side - Left	1	1 of 1
15	Drawer Base	1	1 of 1
16	Front Drawer	1	1 of 1

Piece	Description	Qty	Carton Call
HW1	Cambolt \varnothing 6x32 mm	26	1 of 1
HW2	Camlock \varnothing 15x12 mm	26	1 of 1
HW3	Wooden Dowel \varnothing 8x32 mm	30	1 of 1
HW4	Screw M6 x 50 mm	4	1 of 1
HW5	Screw M7 x 32 mm	4	1 of 1
HW6	Screw M6 x 25 mm	1	1 of 1
HW7	Screw M6 x 12 mm (PH)	8	1 of 1
HW8	Screw Panhead 4 x 10 mm	1	1 of 1
HW9	Metal Runner 1 (300 mm)	1	1 of 1
HW10	Metal Runner 2 (300 mm)	1	1 of 1
HW11	Handle 31x35 mm	1	1 of 1
HW12	Cover Cap Sticker \varnothing 20 mm	11	1 of 1
HW13	Mini Screwdriver 90 mm	1	1 of 1
HW14	Screw M6 x 15 mm	2	1 of 1
HW15	Anti-tip (300 mm)	1	1 of 1
HW16	Screw M10 x 50 mm	2	1 of 1
HW17	Fisher "S" 8x35 mm	2	1 of 1

Special Tips for Fitting Minifix Cam (Cam-Lock), and Minifix Bolt (Cam-Bolts)

CAM-BOLT

Tighten until shoulder is flush with panel. Do not overtighten or undertighten (see example below)

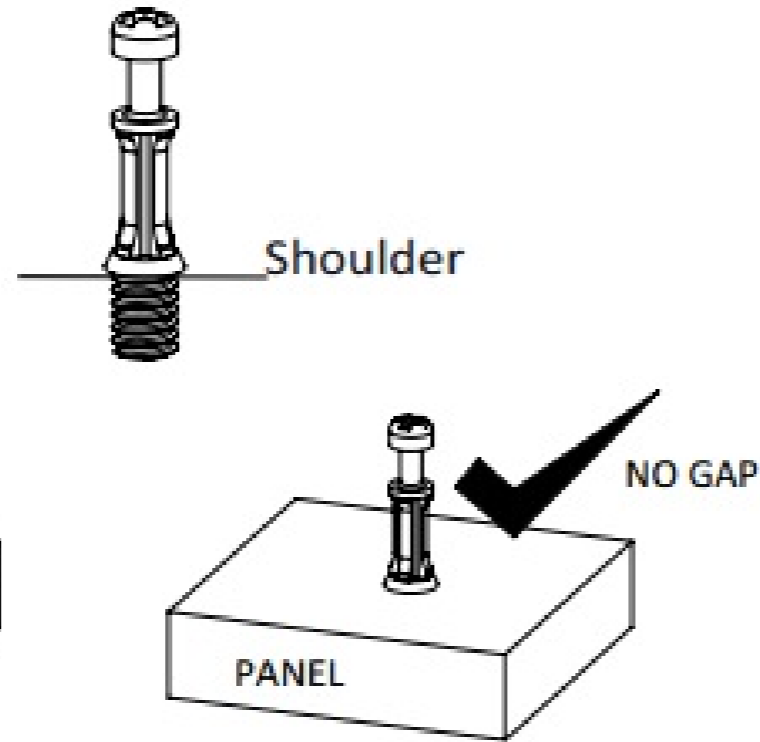

CAM-LOCK

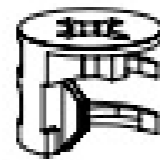

See this Arrow Points !

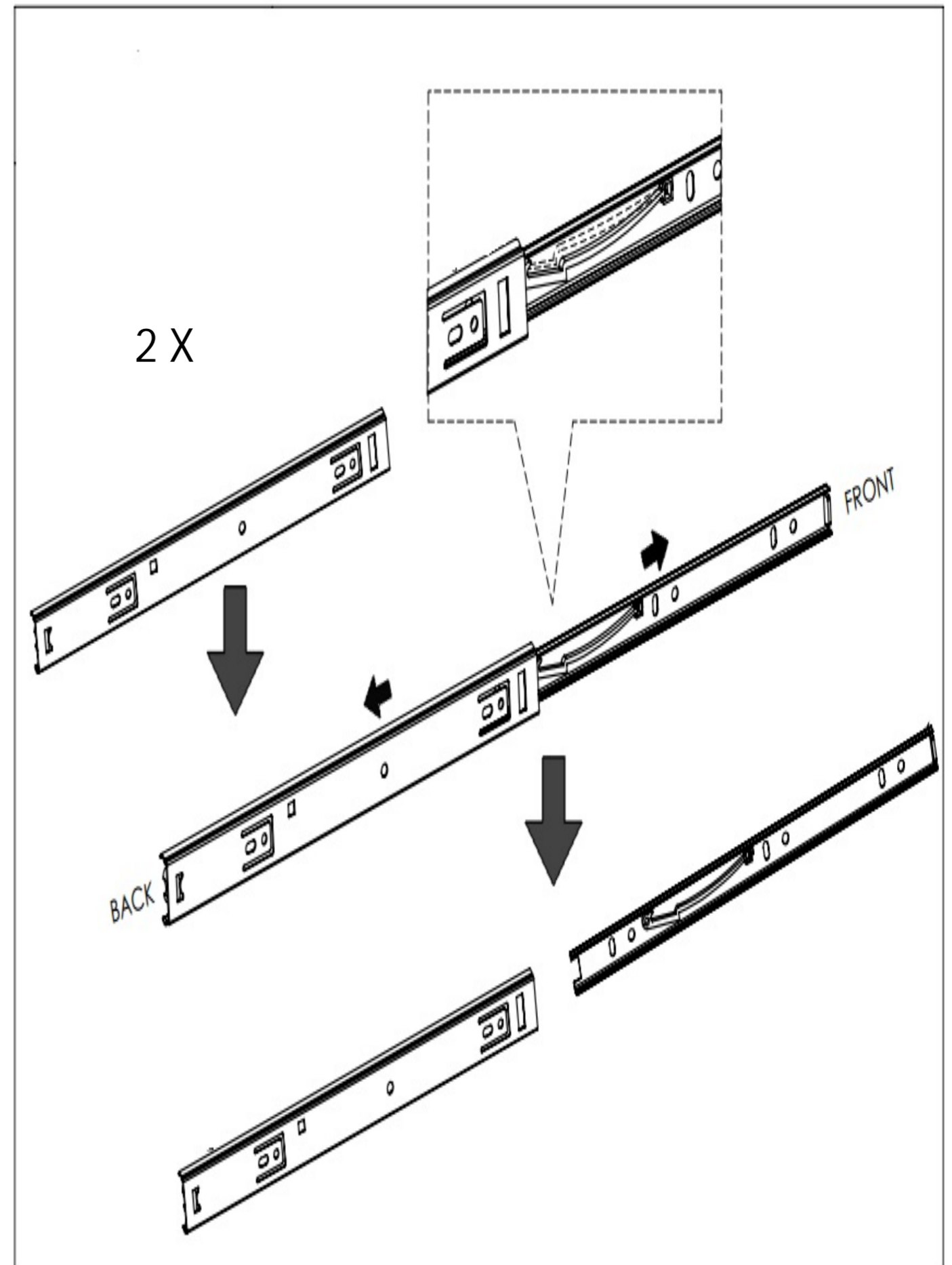
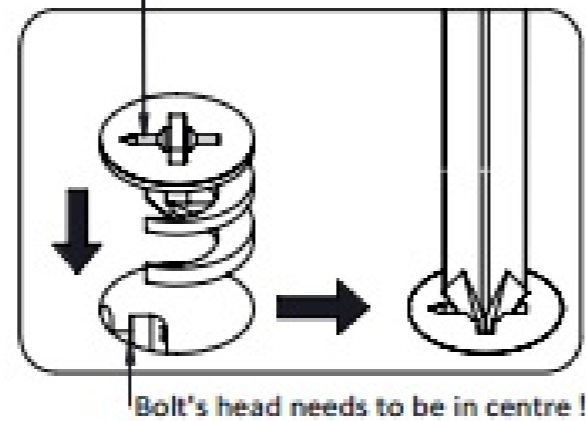
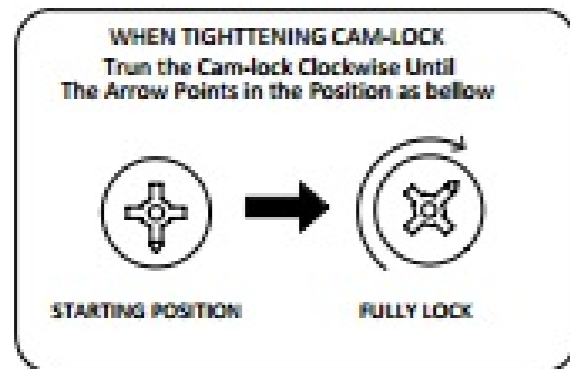

PREPARATION

Before beginning assembly of product, make sure all part are present. Compare part with part contents list and hardware contents list.

If any part is missing or damaged, do not attempt to assemble the product.

Estimated Assembly Time: 60 minutes.

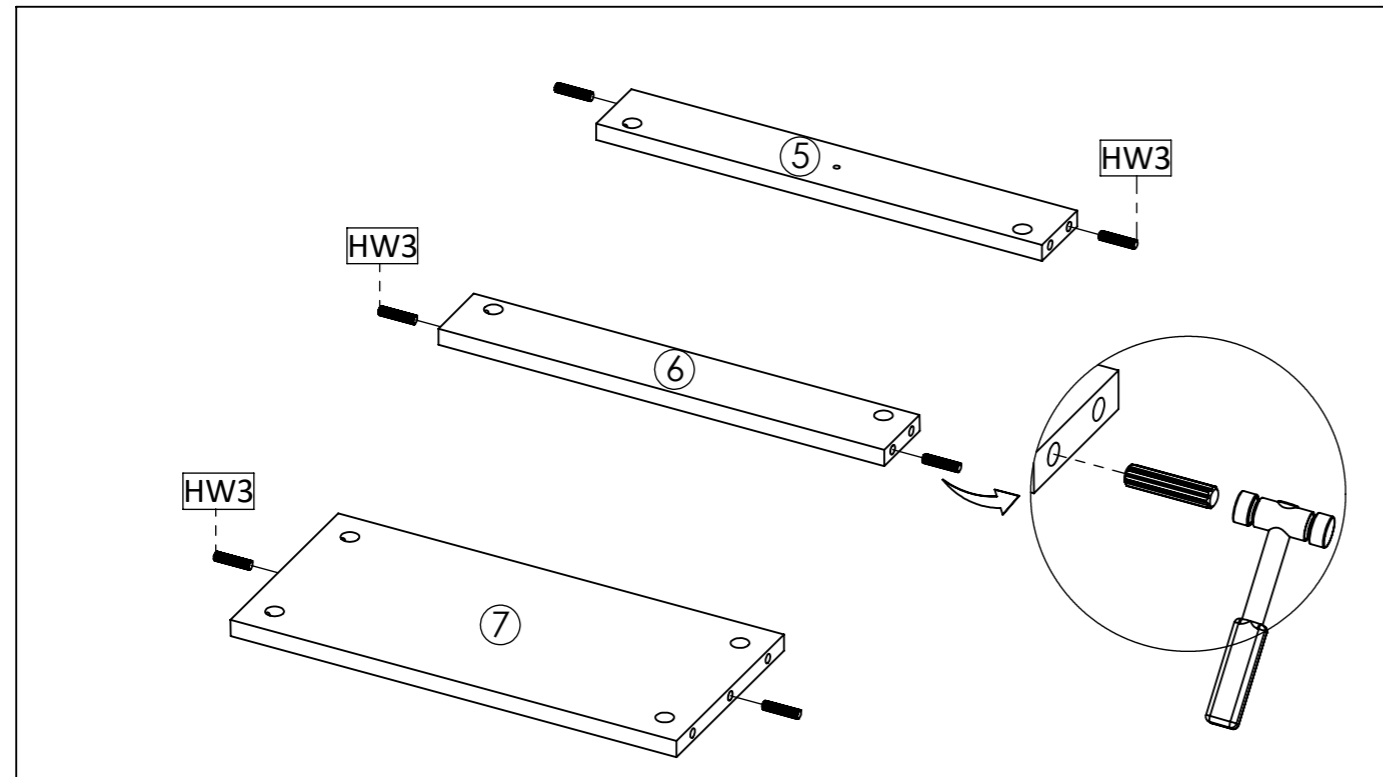

STEP1: Insert wooden dowel (HW3) into upper apron (5), lower apron (6) and back panel (7).

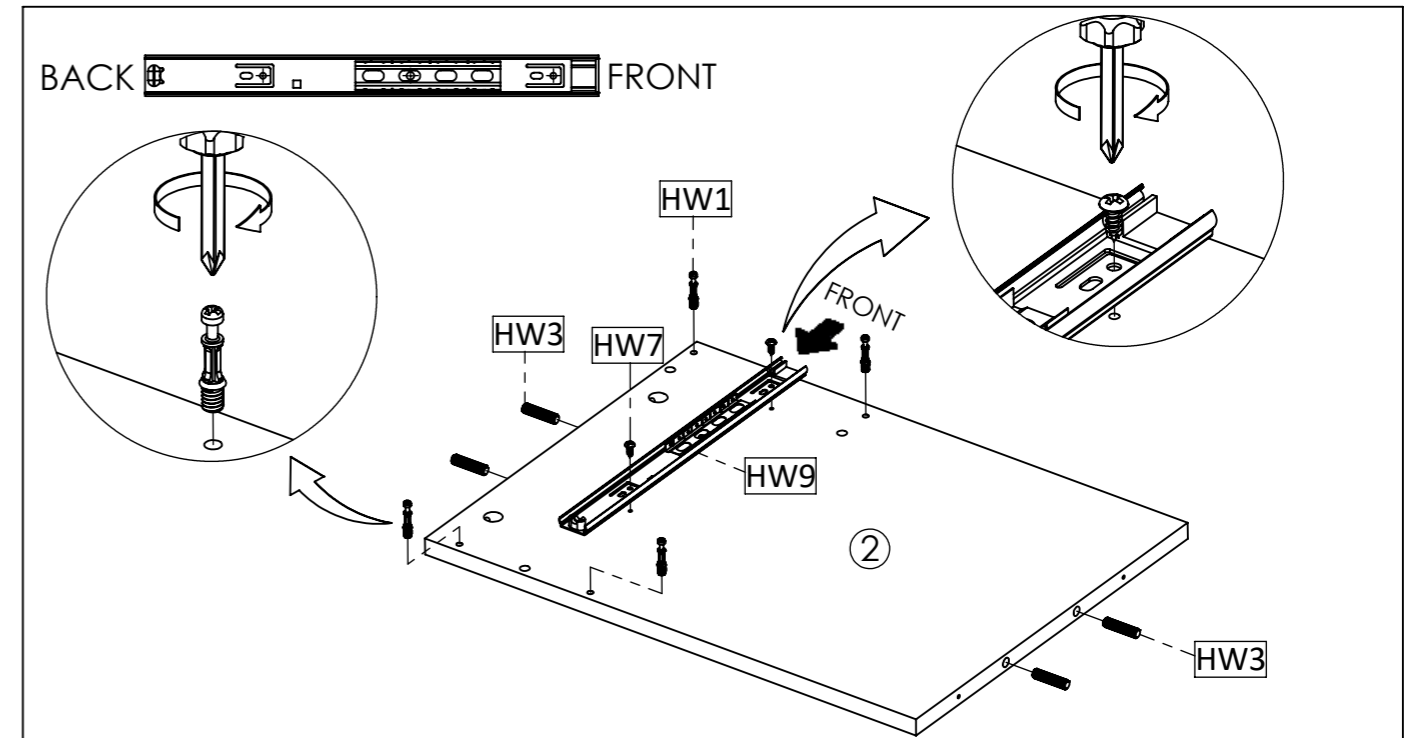

STEP2: Install the metal runner 1 (HW9), into position as shown in picture, Secure with screw M6 x 12 mm PH (HW7). Continue insert wooden dowel (HW3) and cambolt (HW1) into side panel - right (2), tighten it using screwdriver.

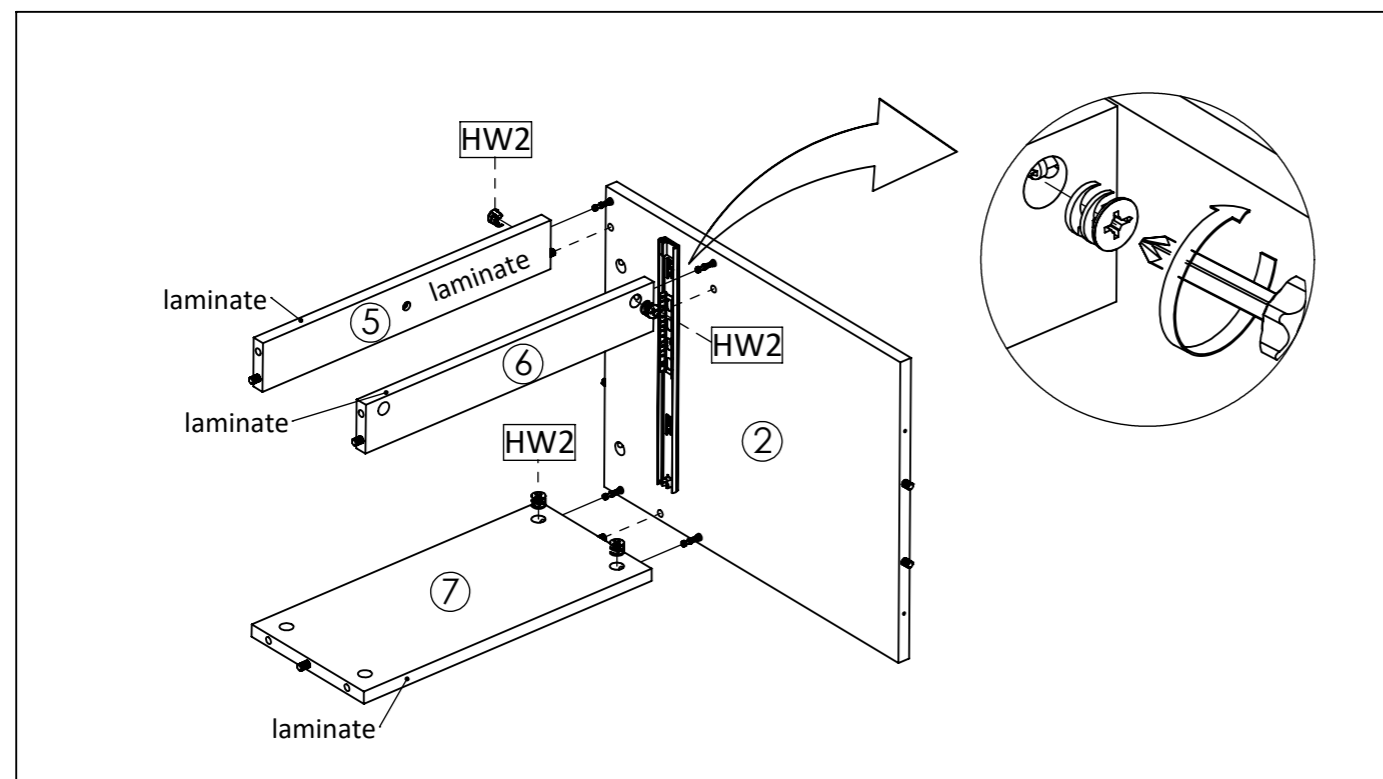

STEP3: Insert upper apron (5), lower Apron (6) and back panel (7). Into side panel - right (2), secure with camlock (HW2) tighten it using screwdriver.

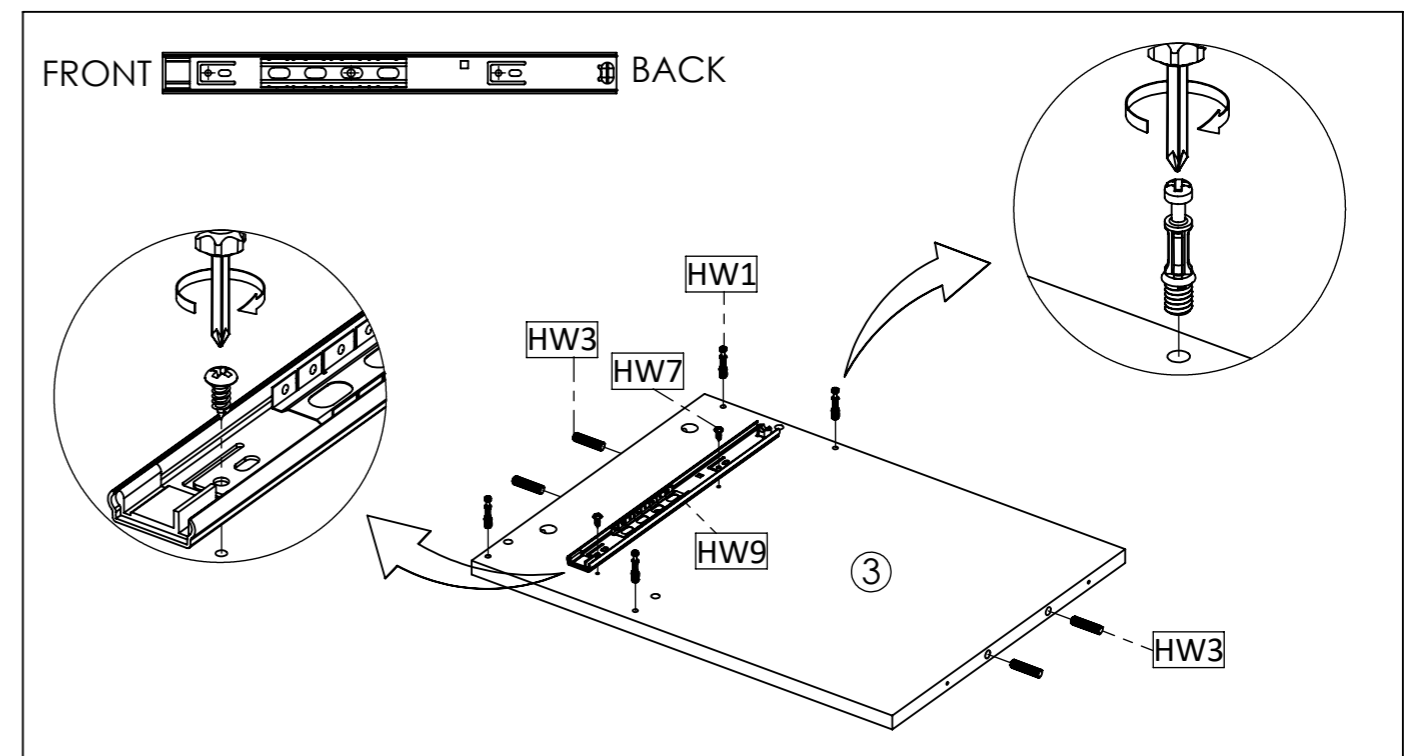

STEP4: Install the metal runner 1 (HW9), into position as shown in picture, Secure with screw M6 x 12 mm PH (HW7). Continue insert wooden dowel (HW3) and cambolt (HW1) into side panel - left (3), tighten it using screwdriver.

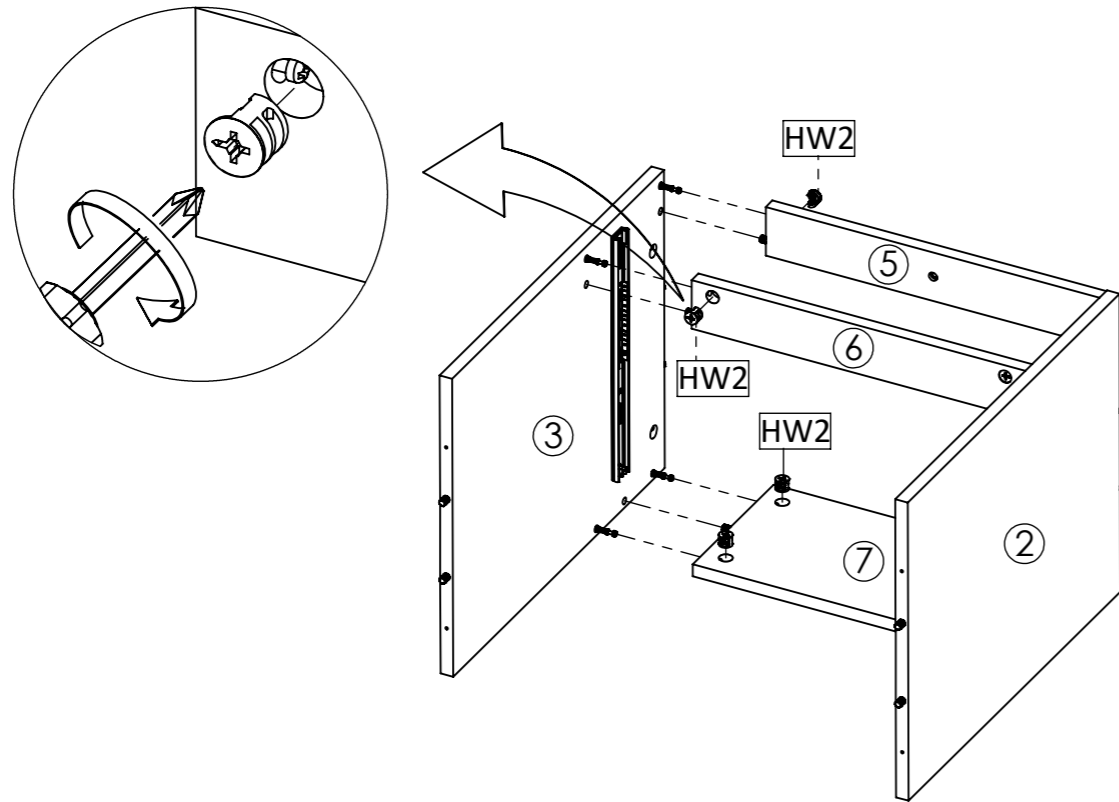

STEP5: Insert side panel - left (3) Into upper apron (5), lower Apron (6) and back panel (7). Secure with camlock (HW2) tighten it using screwdriver.

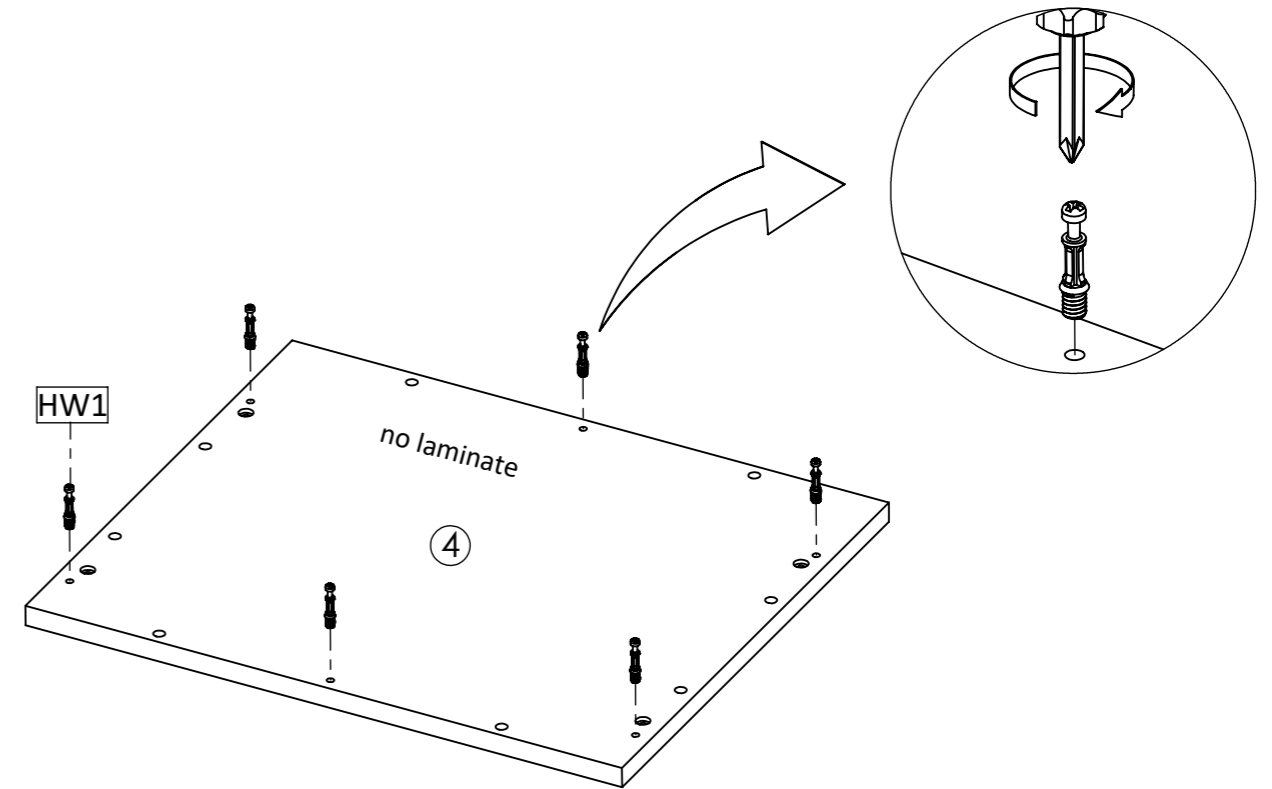

STEP6: Insert cambolt (HW1) into Bottom Panel (4), tighten it using screwdriver.

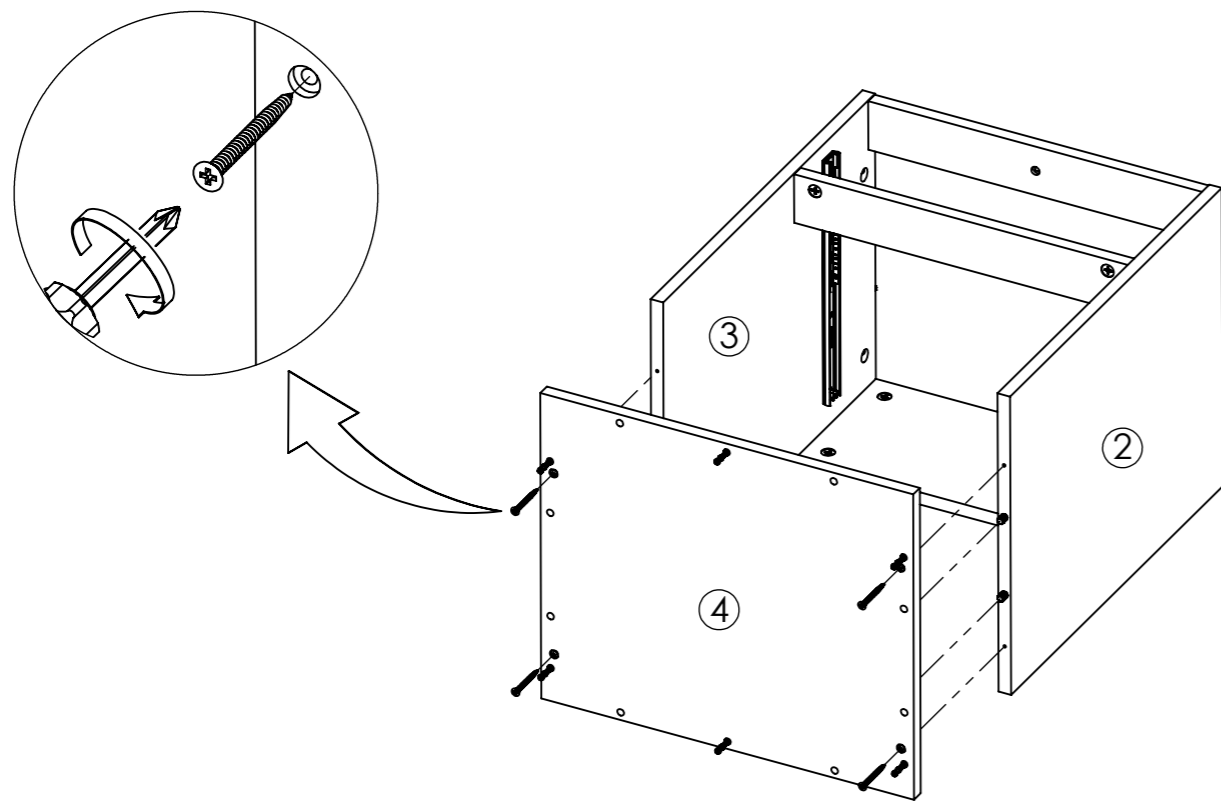

STEP7: Insert bottom panel (4) into side panel - right (2) and side panel - left (3). Secure with screw M6 x 50 mm (HW4) tighten it using screwdriver.

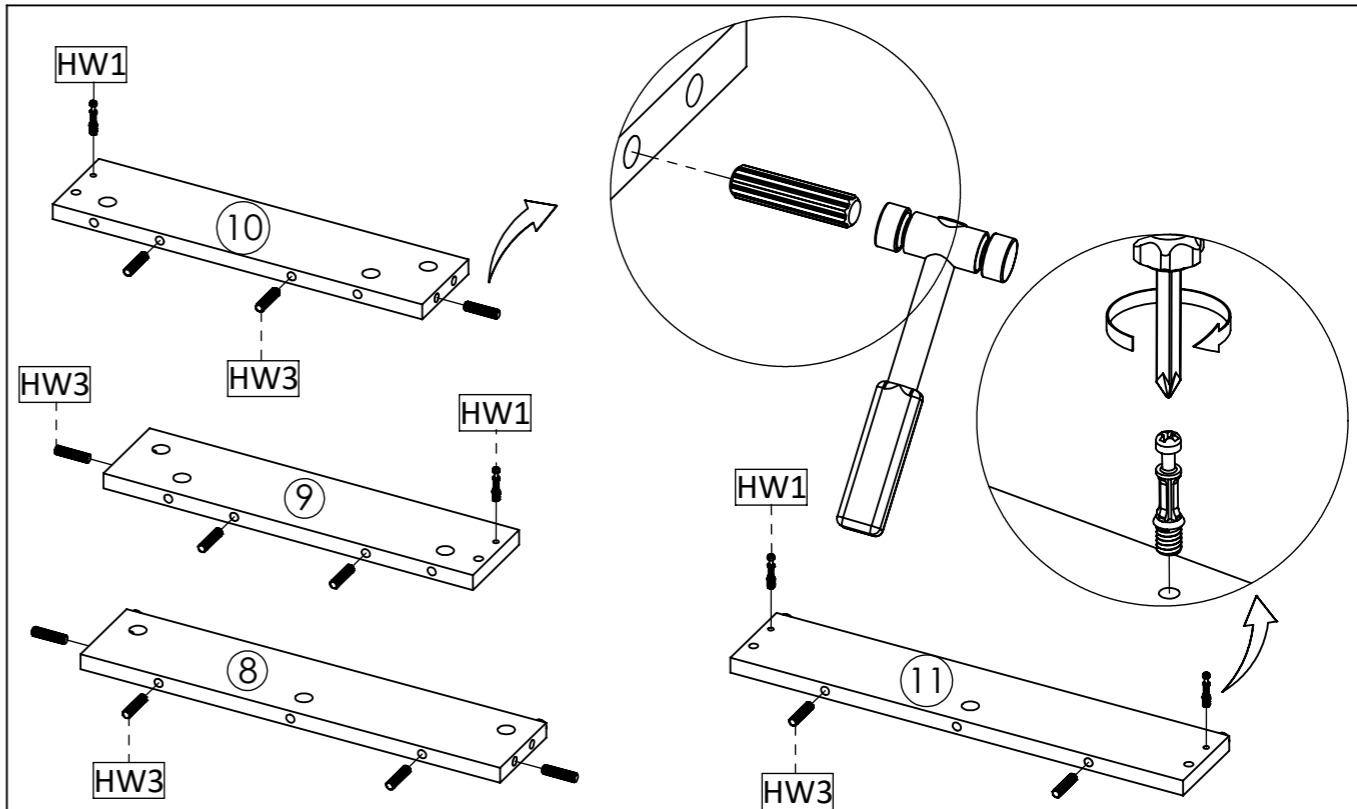

STEP8: Insert wooden dowel (HW3) into Plint - Rear (8), Plint - Right (9), Plint - Left (10) and Plint - Front (11), Continue insert cambolt (HW1) Into Plint - Right (9), Plint - Left (10) and Plint - Front (11) tighten it using screwdriver.

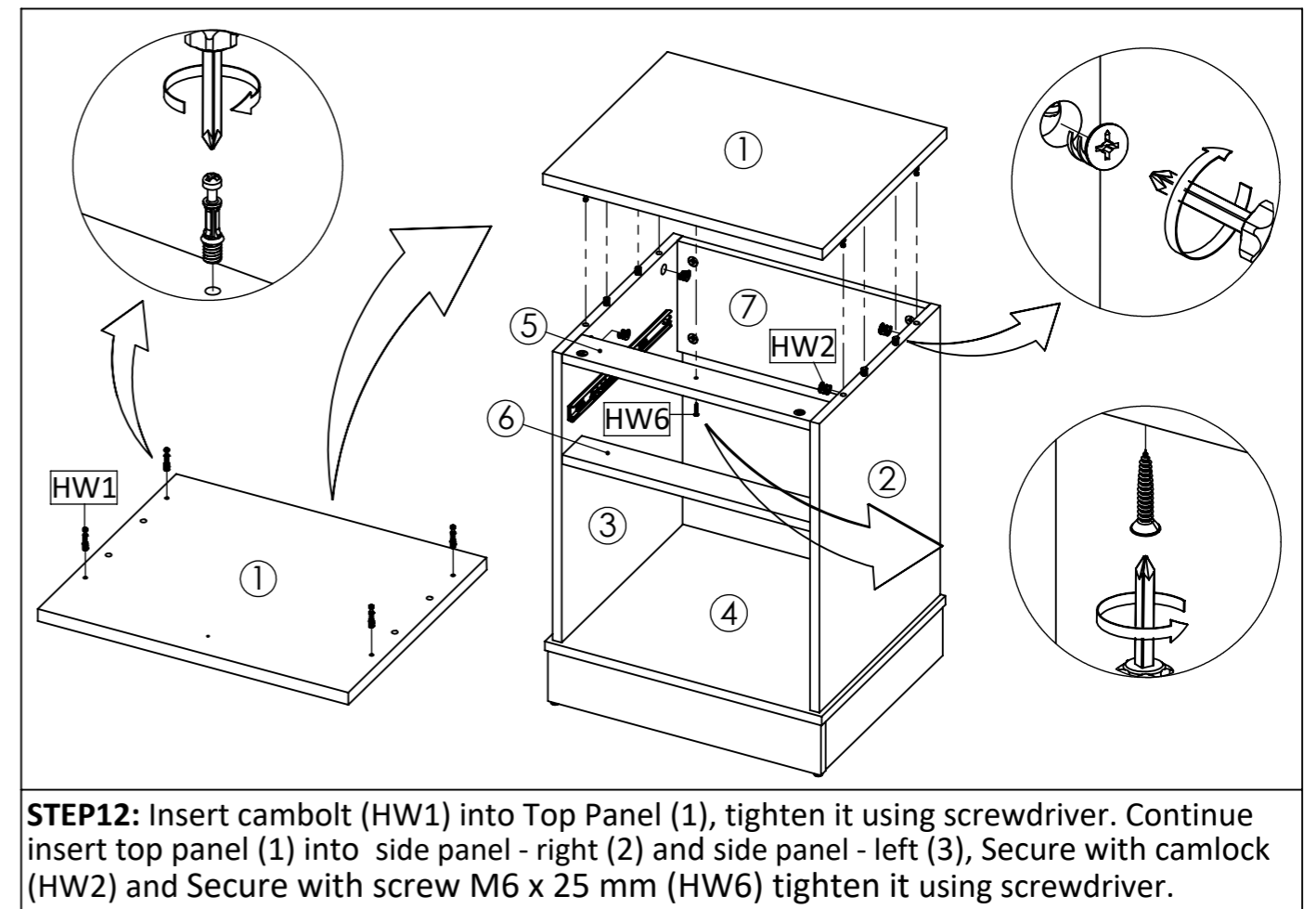
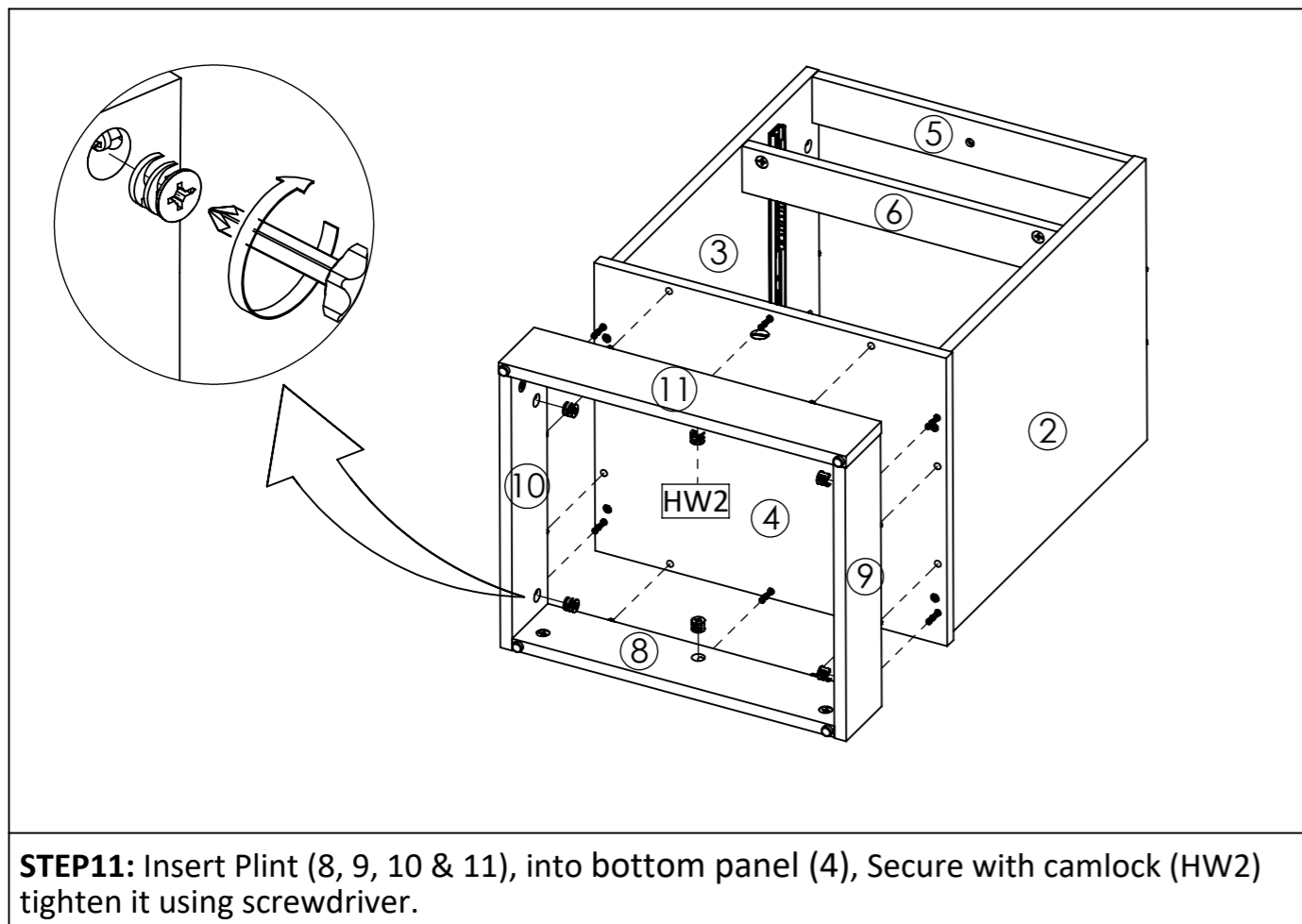
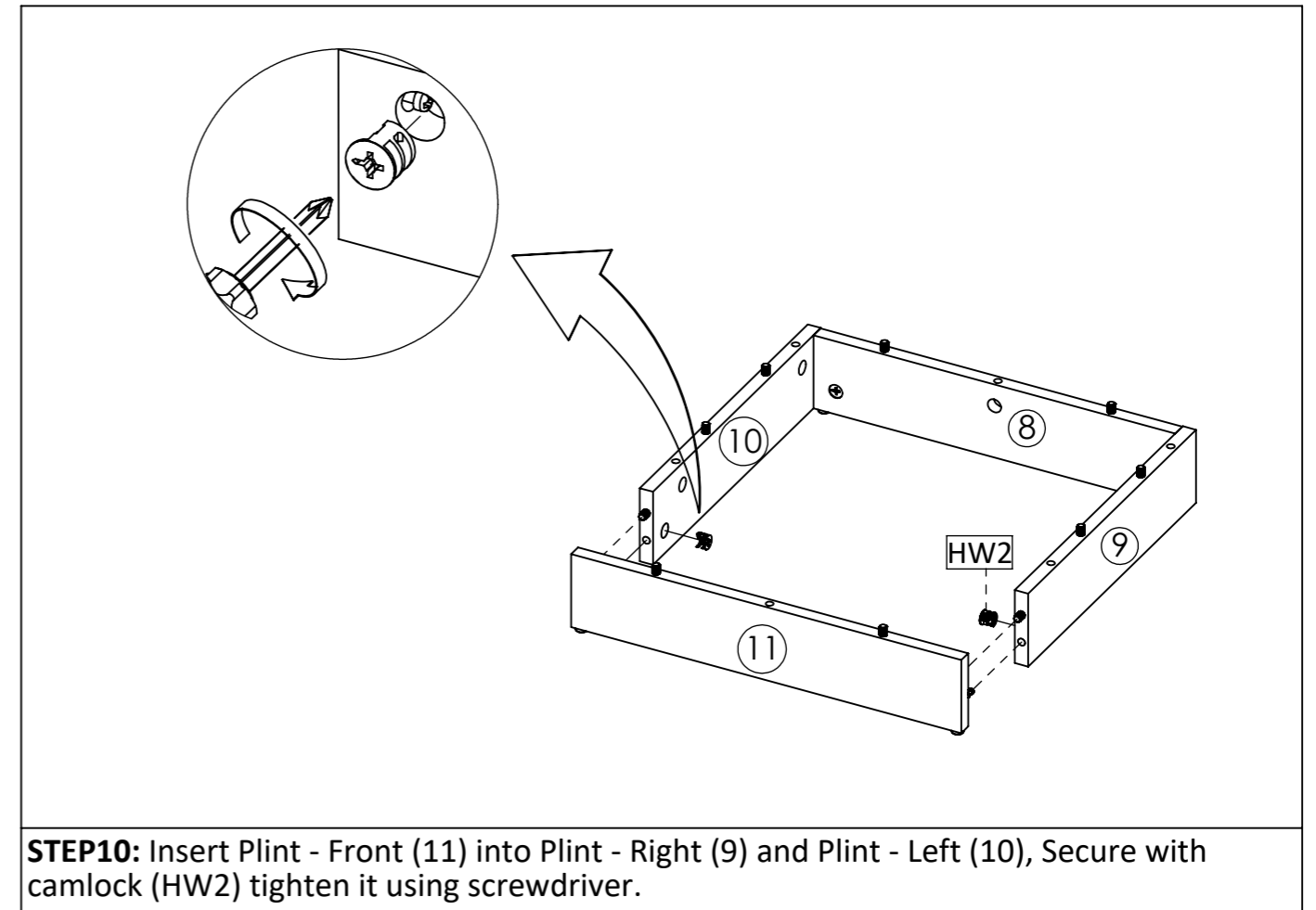
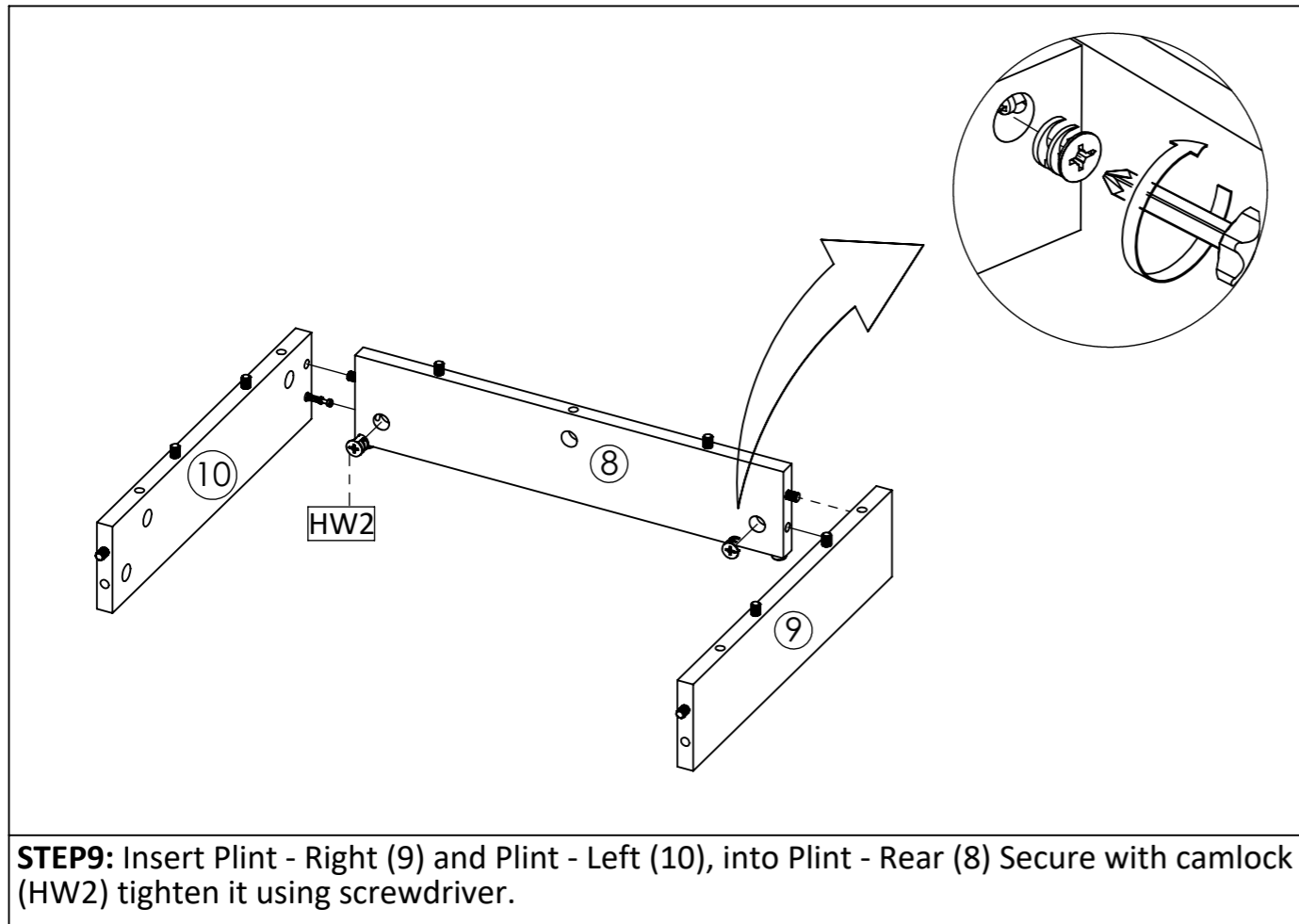

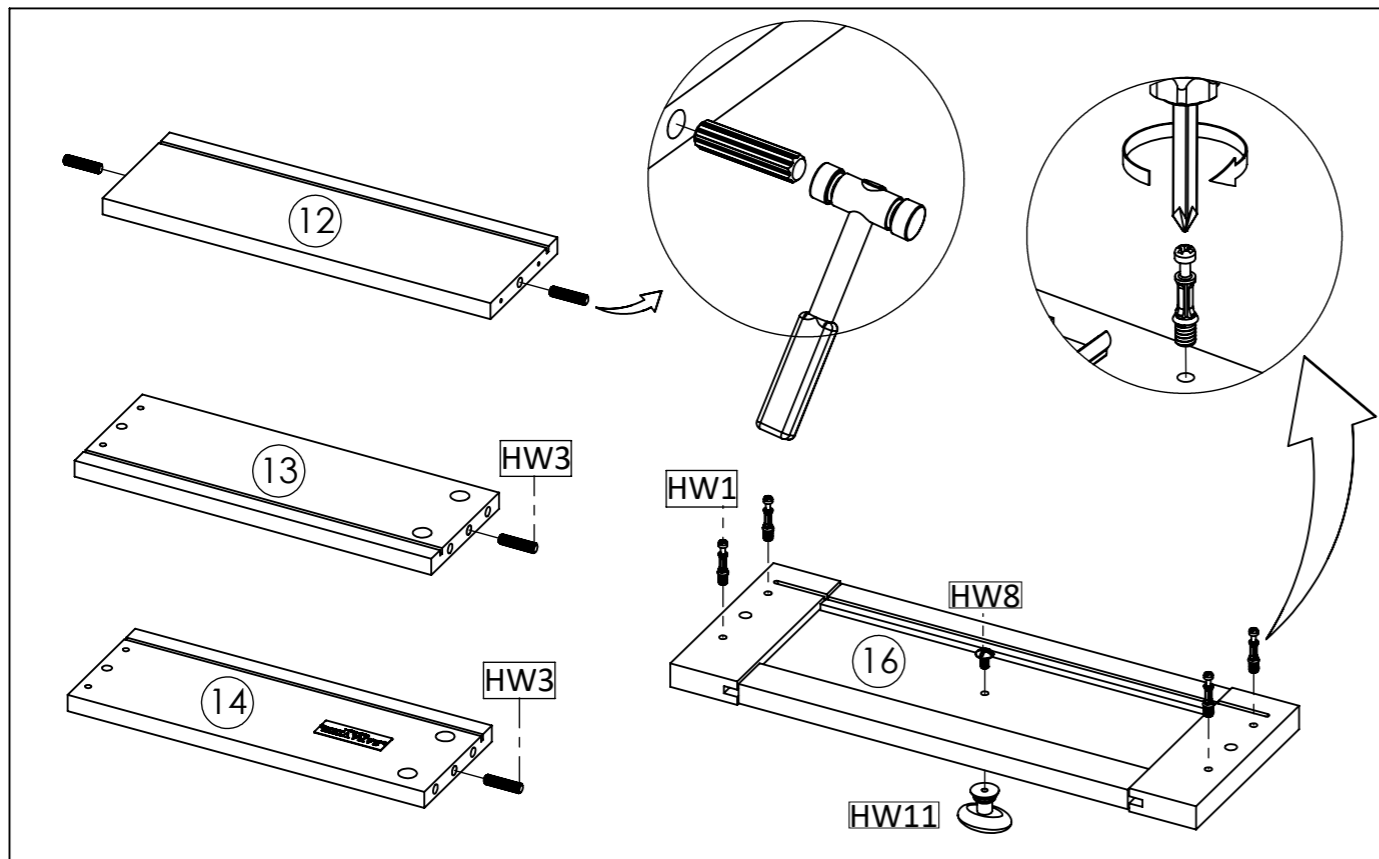

STEP13: Insert cambolt (HW1) and handle (HW11) into front drawer (16) scure with Screw Panhead (HW8) tighten it using screwdriver. continue Insert wooden dowel (HW3) into drawer side - right (13), drawer side - left (14) and drawer back (12).

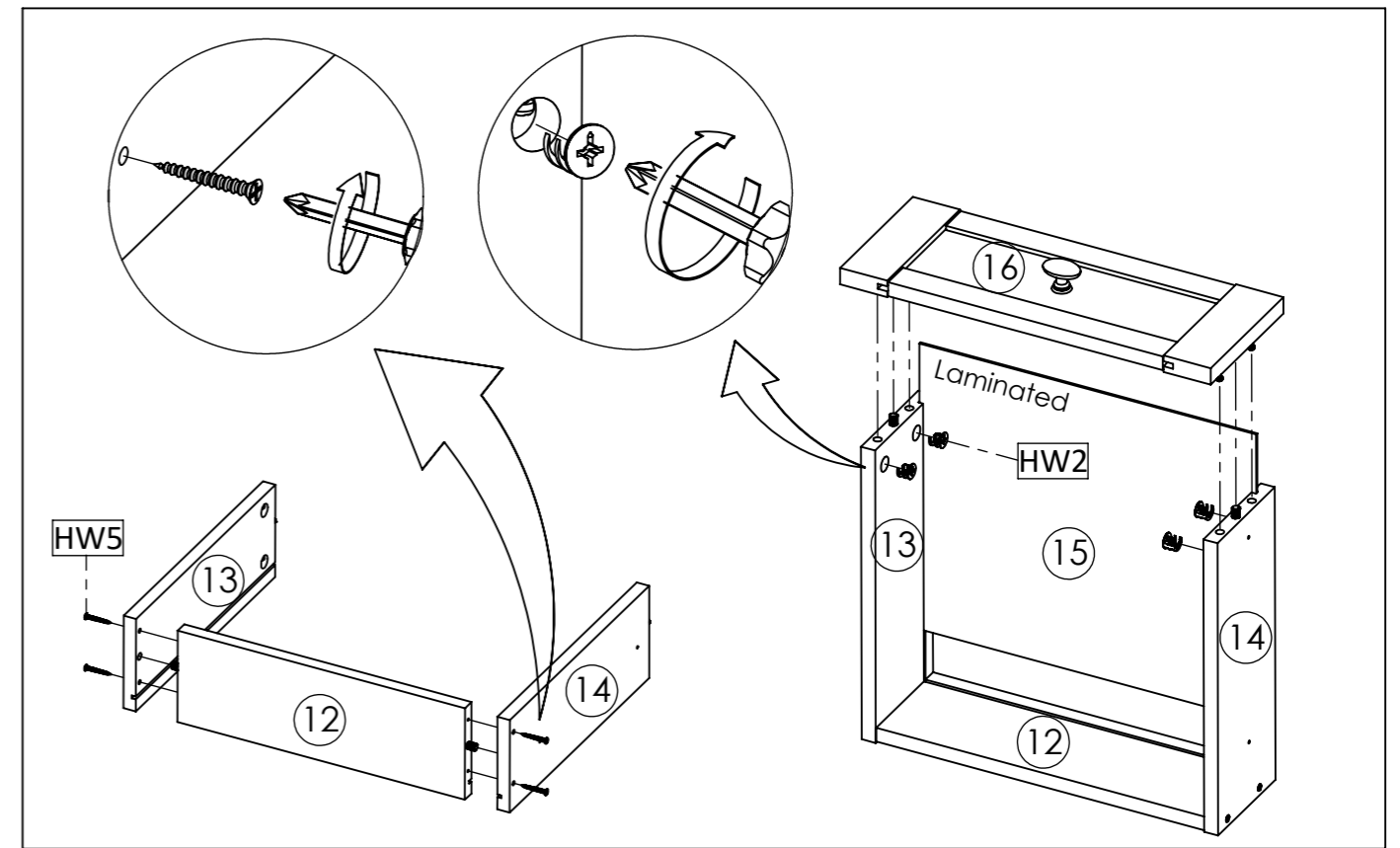

STEP14: Combine drawers side (13 & 14) into drawer back (12) secure with screw M7x32mm (HW5). Continue insert drawer base (15), Then put front drawer (16) then tighten camlock (HW2) It using screwdriver.

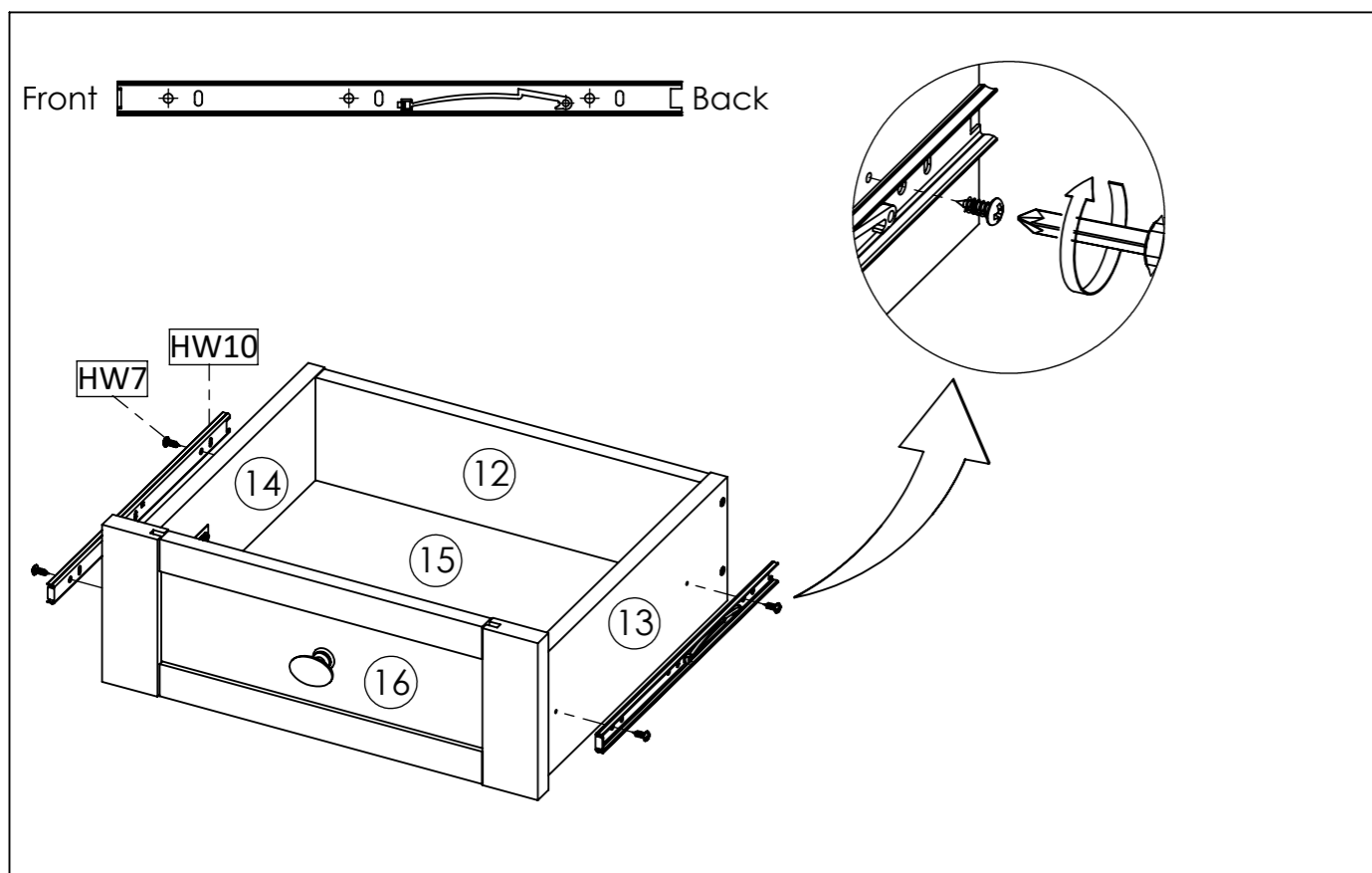

STEP15: Instal the metal runner 2 (HW10) Into position as shown in picture. Secure with screw M6 x 12 mm PH (HW7) and tighten it using screwdriver.

SPECIAL TIPS FOR DRAWER SLIDE ASSEMBLY

NOTES: The drawer might stop partway the first time slide it in. Just push a bit harder to close it. It will wok smoothly after that.

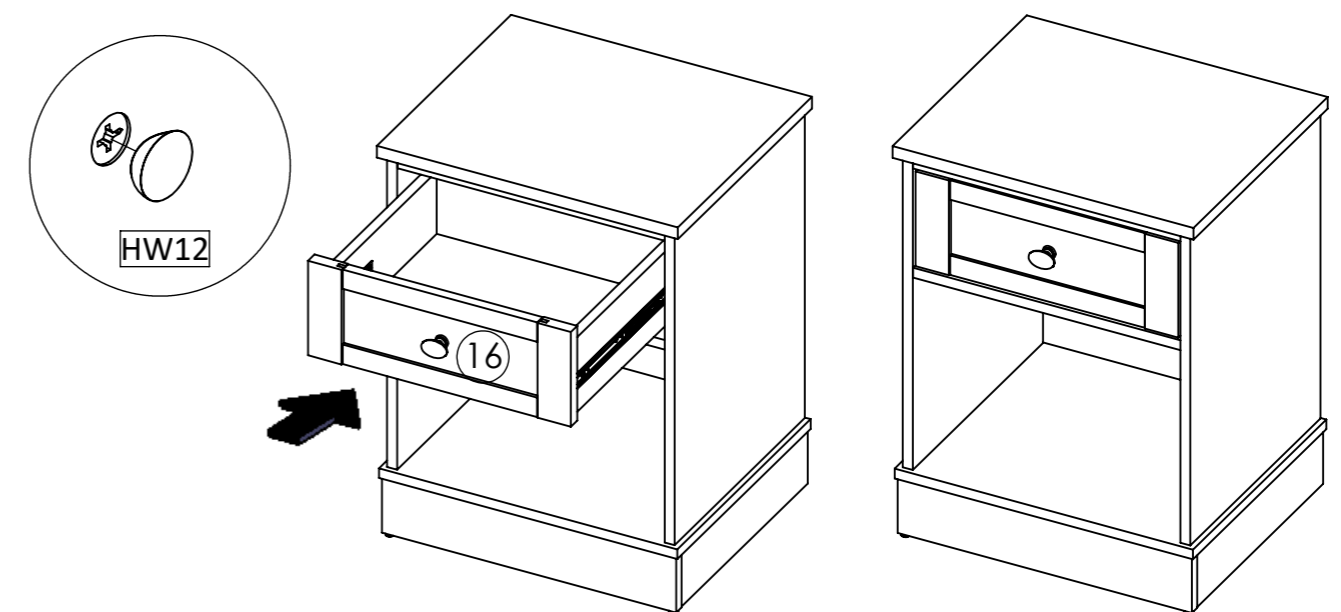

STEP16: Hold the sides of drawer, position the wheel of rail at drawer back, and the wheel of rail at side boards, according to the image. Attach Cover Cap Sticker (HW12) to the panel that has lamination. Assembly is complete



ANTI-TIP RESTRAINT INSTALLATION

! WARNING!

Children have died from furniture tipover.
To reduce the risk of furniture tipover:

- ALWAYS install tipover restraint provided.
- NEVER allow children to stand, climb or hang on drawers, doors, or shelves.
- NEVER open more than one drawer at a time.
- Place heaviest items in the lower drawers.

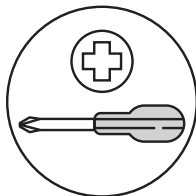
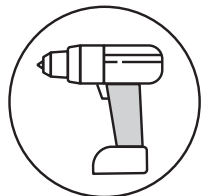

REQUIRED TOOL
8MM / 5/16" DRILL BIT

REQUIRED TOOL

! Hardware (HW11 / HW7) to attach brackets to wall is designed for drywall. To attach this unit to another type of wall, consult with your local hardware store.

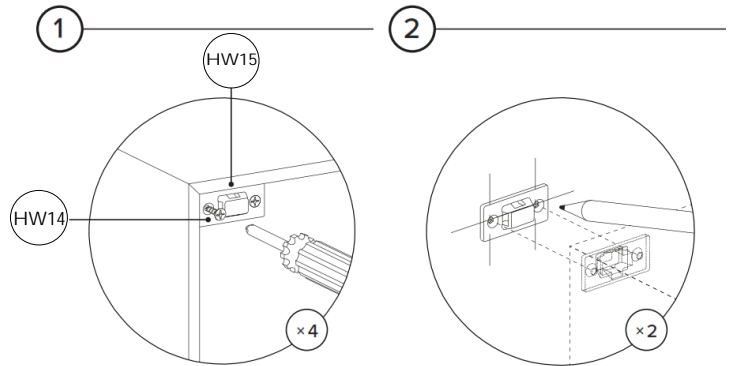

Attach pair of brackets to "Top Panel" of the unit. Note there are no existing pilot holes on the product.

Mark on wall where second pair of brackets should be placed.

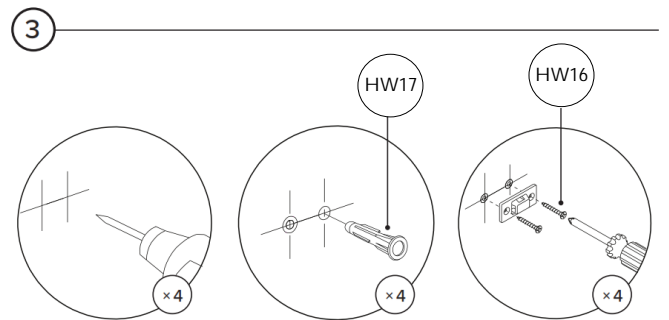



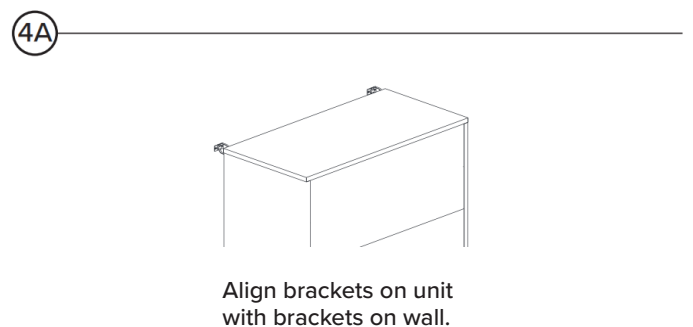

Drill holes in wall using 8mm / 5/16" drill bit.

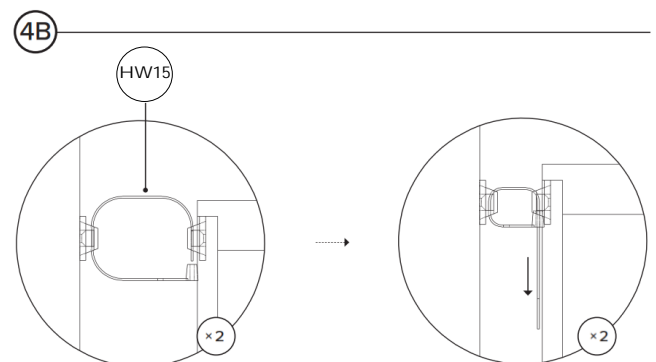

Align brackets on unit with brackets on wall.



Pull strap down until it snap-locks.

ANTI-TIP RESTRAINT PACK		
ID	DESCRIPTION	QTY
HW15	BRACKET 	2
HW14	M6 × 15MM SCREW 	2
HW17	M8 × 35MM 	2
HW16	M10 × 50MM SCREW 	2
HW15	STRAP 	1