

## Drop Leaf Counter Table Counter Storage Base

Product size : 59" x 59" x 36"H

Your furniture purchase is an investment. Here are a few tips to maximize the lifetime of your furniture with a minimum amount of effort. Properly caring for your furniture can help ensure that it looks great year after year.

### Wood Furniture Maintenance:

- Always dust, wipe, and clean *with* the grain of the wood.
- Dust with a soft cloth. Dust will scratch the furniture surface if not removed properly.
- Use the same type of polish consistently as interchanging oil-based and wax-based polishes will cause a build-up and result in a foggy or cloudy appearance.
- If a polished surface becomes foggy, rub it with a cloth dipped in a solution of one tablespoon vinegar to one quart of water. Rub softly with the grain until the surface is completely dry.
- Soap and water are not advisable for wood surfaces. Water can penetrate the finish and raise the grain on wood, causing damage.
- Remember to change dusting cloths frequently as dirty cloths may scratch your furniture's surface.

### The Enemies of Wood:

- Moisture is wood's worst enemy. Liquid spills should be gently wiped up immediately. Coasters should be used under all beverages.
- Do not allow rubber or vinyl materials to lie on the furniture. Chemicals in rubber may leave a stain. Put a strip of felt or leather under accessories that have rubber or vinyl.
- Heat creates a chemical change in the furniture's finish, which results in a white spot. Use protective pads under hot dishes, appliances, etc.
- Sunlight's ultraviolet rays can damage the finish of furniture. Do not place furniture directly against a heater or radiator and do not place in the path of hot streams of air from central heating. This will cause extreme localized drying of the wood.

### High Gloss Resin Table Maintenance:

- Resin tabletops have approximately 1/8" of a resin coat on the top face of the table, which will resist ice, water, wine, liquor, food, cleaning fluids, and warm or hot liquids; however, cups, glasses, etc. containing hot liquids should not be left on the table without a coaster for protection.
- Resin tabletops will scratch just the same as any other glossy surface and basic precautions should be taken.
- For lasting shine, the resin table should be waxed with a car wax that does not contain silicon. Maintaining this wax build-up will result in a high gloss shine.
- When wiping down the table, a soft, clean rag should be used. Do not use a heavy paper.

### Granite Top Maintenance:

The surface of the granite on your table has been polished or sealed to create a generally non-porous surface. The stone has many natural characteristics including: veining, hairline cracks, and color variations - which make up the stone's beauty.

To maintain the beauty of your granite:

- Protect surfaces from scratching, staining and etching by:
    - \* Keeping them free of debris or sharp objects
    - \* Wiping up spills immediately
    - \* Avoiding contact with chemicals (particularly acid-based materials)
  - Clean with pH neutral products or those especially formulated for use on stone.
  - It is not recommended to use a water-based solvent for dark granite as it will remove the polish from the surface.
  - After a period of use, apply a penetrating sealer to prevent contaminants from being absorbed into the stone.
  - Remove stains with special absorbent poultices formulated for use on stone.
  - Renew the surface on polished granite (granite with a high gloss surface) by buffing with special stone polish, powder or cream.
- Do not use granite polish on granite with a matte finish, which has been honed rather than polished. (Penetrating sealer may be used on both polished and honed granite.)







### Marble Top Maintenance:

Marble may be stone, but it is porous stone and can stain easily. Treating marble surfaces the same as wood surfaces is a great rule of thumb.

- It is recommended to seal the tops on a regular basis (every 6 to 12 months). A good quality stone sealer can be purchased from any tiles/stone store or any homecare store and should be applied according to the manufacturer's recommendation.
- When sealed properly, marble tops can be used indoors and outdoors and can withstand any weather conditions except internal freezing. Snow or freezing rain will penetrate the table and cause cracks.

### Caring for the Fabric on Upholstered Furniture:

- Frequent vacuuming of the entire upholstered area will prevent dust from settling into the fibers.
- Professional cleaning is always recommended for all upholstered pieces.
- Always pre-test a small area of fabric in an inconspicuous area when cleaning before proceeding.
- Do not use cleaning products containing brightening agents.

VERY IMPORTANT!!					
<p><b>NEVER</b> USE GLASS CLEANERS ON FINISHED SURFACES. AMMONIA WILL CHEMICALLY ATTACK THE FINISH.</p>	<p>DO NOT WRITE DIRECTLY ON SURFACE</p>  <p><b>PREVENT MARKING</b></p>	<p>DO NOT PLACE DIRECTLY IN SUNLIGHT</p>  <p><b>PREVENT FADING</b></p>	<p>DO NOT USE PLACEMATS WITH RUBBER BASES</p>  <p><b>PREVENT DISCOLORING</b></p>		
<p><b>NEVER</b> ALLOW LIQUIDS OF ANY KIND TO LINGER ON SURFACES. ABSORPTION CAUSES THE WOOD TO WARP AND THE FINISH TO DE-LAMINATE.</p>	<p>DO NOT USE COMMERCIAL POLISHES AND WAXES</p>  <p><b>PREVENT YELLOWING</b></p>	<p>DO NOT PLACE HOT POTS, ETC. ON SURFACE</p>  <p><b>PREVENT DAMAGE TO FINISH!</b></p>	<p>REGULATE THE HUMIDITY CONDITIONS AT YOUR HOME</p>  <p><b>PREVENT SPLITTING</b></p>		

# ASSEMBLY INSTRUCTIONS

## STEP 1:

Turn the Table top (A) upside down on a flat soft surface.

Attach Leaf holder (6) to the table top (A) using short bolt (7) and tighten with Allen key (5).

Unlock Leaf Holder (6) by turning it counterclockwise. Open table leaves and pullout table woodglides in order to hold table leaves in place.

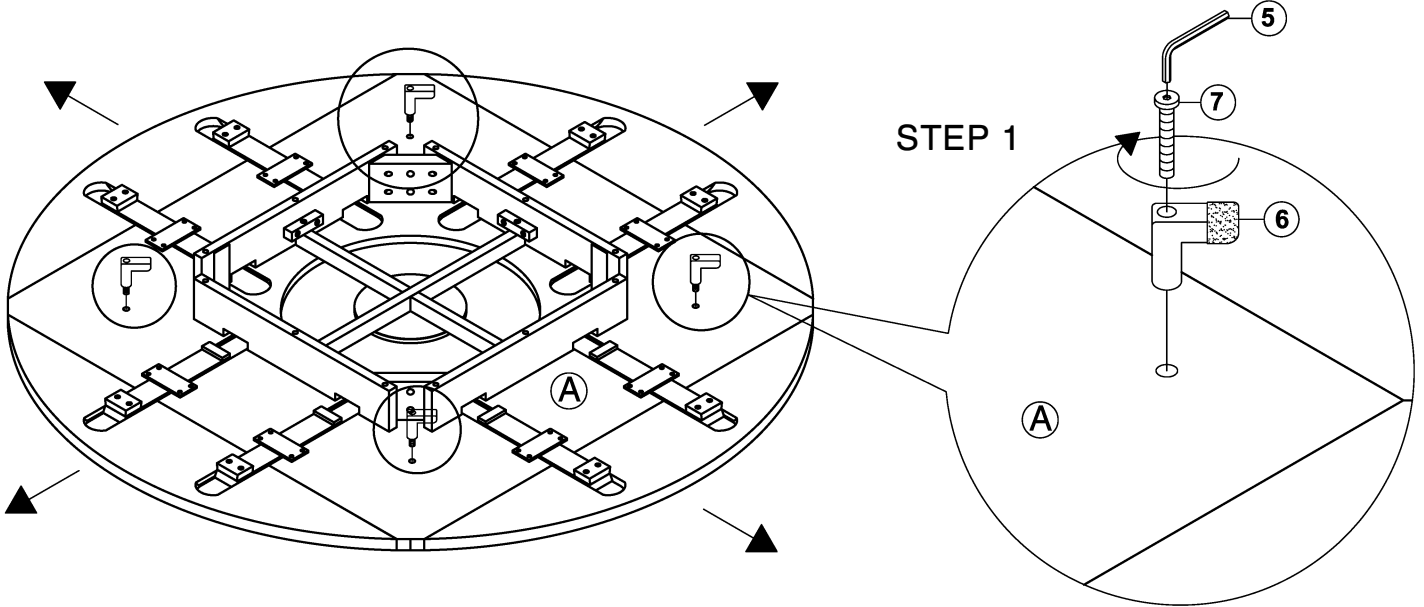

## STEP 2:

Remove drawer from table base (C). Attach table legs (B) to table base (C) with spring washers (2) and short bolts (3), using Allen key (5). Then install the drawer back to the table base (C).

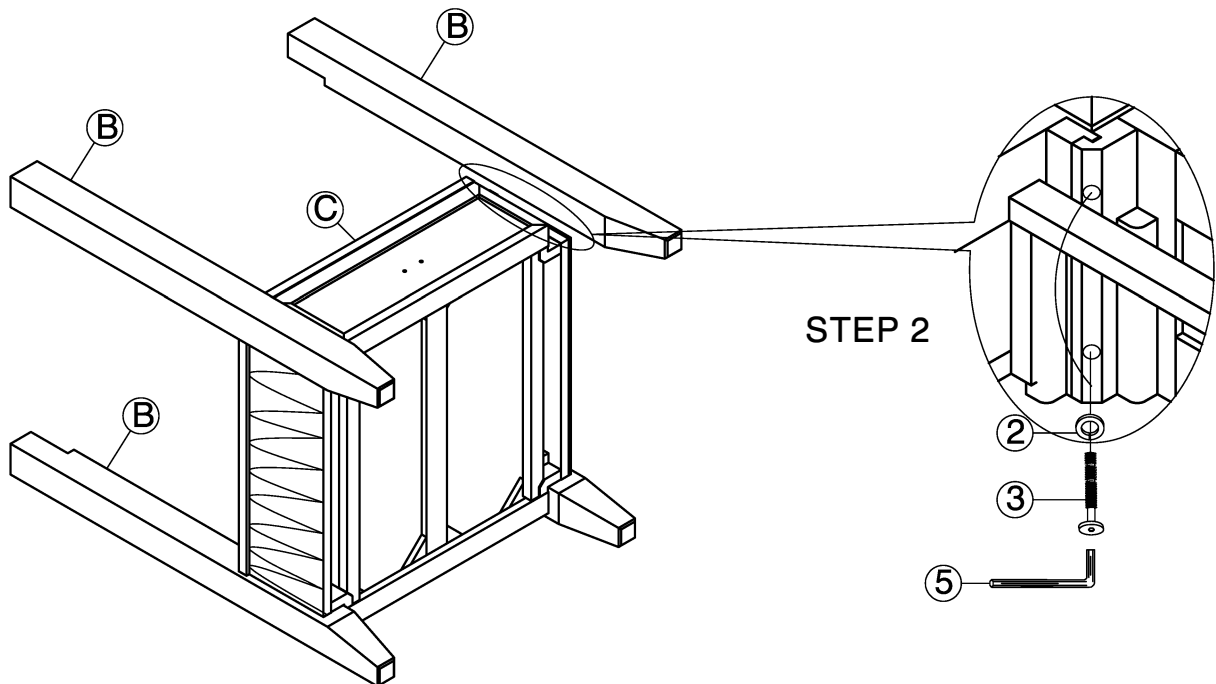

# ASSEMBLY INSTRUCTIONS

**STEP 3:**

Attach table top (A) to table legs (B) with flat washers (1), spring washers (2) and long bolts (4), using Allen key (5).

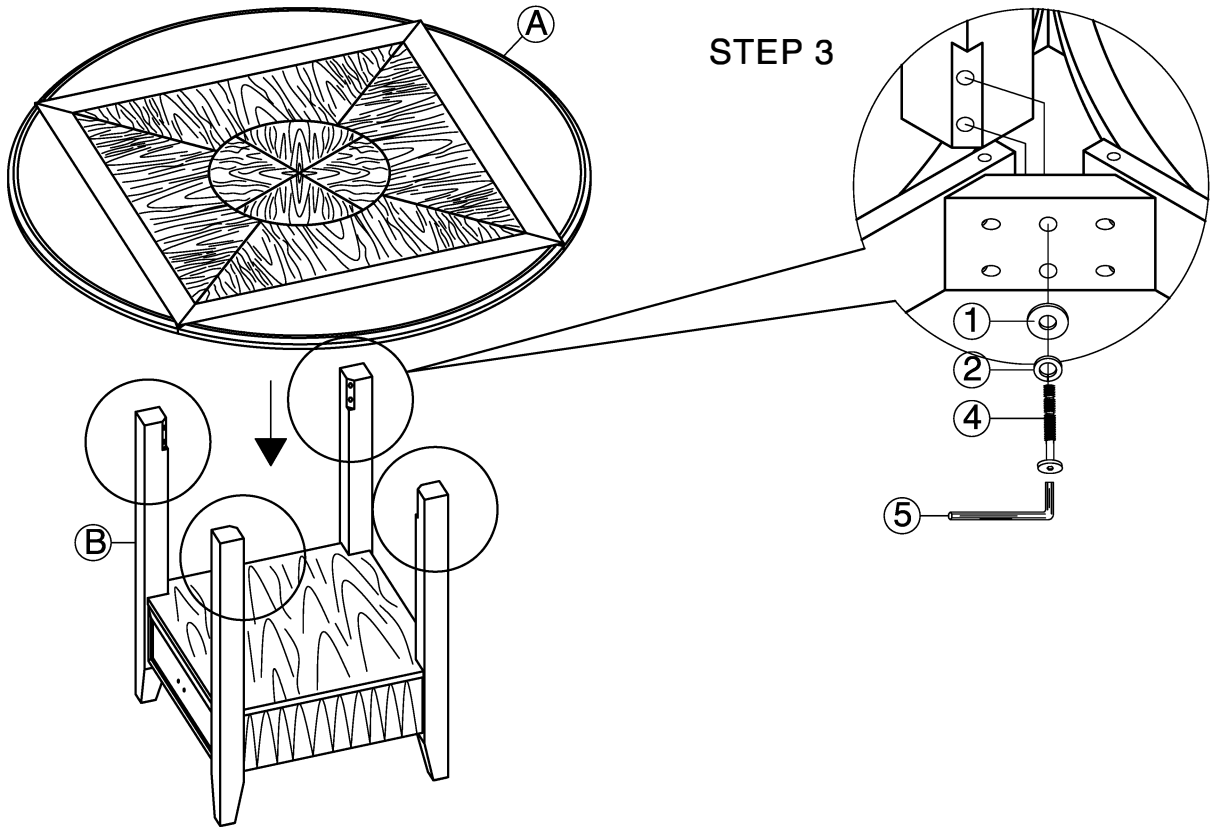



**Caution:**

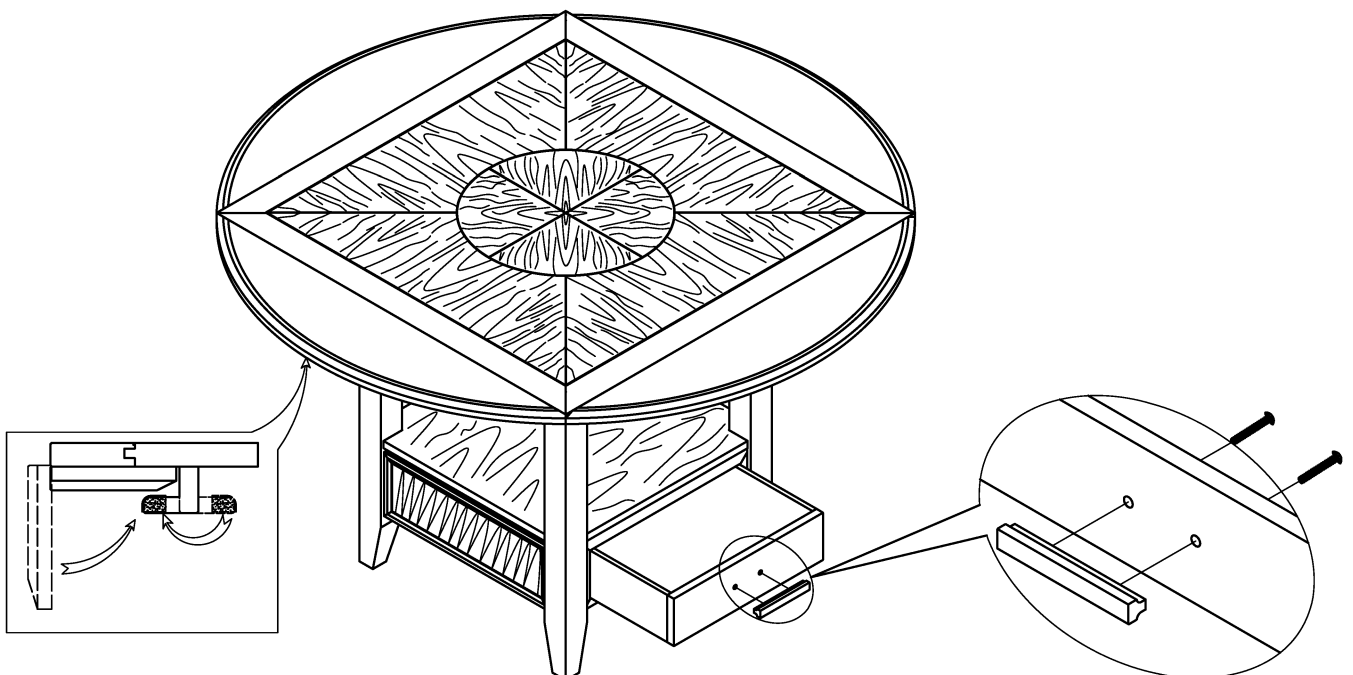

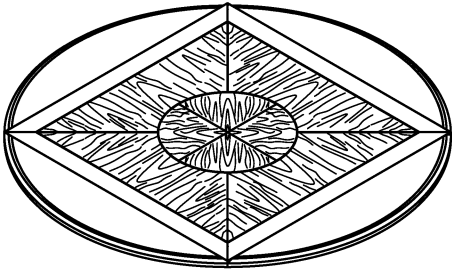

Please make sure all leaves are closed in before you move the table.

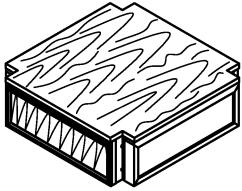

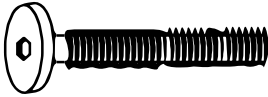
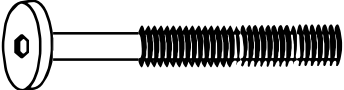

## PARTS LIST

(A) TABLE TOP (1PC)	(D) TABLE LEG (4PCS)	(C) DRAWER (1PC)
		

## HARDWARE PACK

NO.	DESCRIPTION	DIMENSION	Q'TY
1	FLAT WASHER		$\phi 5/16'' \times 19$ 8PCS
2	LOCK WASHER		$\phi 5/16'' \times 12$ 16PCS
3	SHORT BOLTS		$\phi 5/16'' \times 50$ 8PCS
4	LONG BOLTS		$\phi 5/16'' \times 70$ 8PCS
5	ALLEN KEY		NO.4 1PC

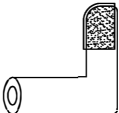
## HARDWARE PACK

NO.	DESCRIPTION	DIMENSION	Q'TY
6	LEAF HOLDER		20 x 49mm 4PCS
7	SHORT BOLTS		$\phi 1/4'' \times 55$ 4PCS

# PARTS FOR COMPLETE HARDWARE

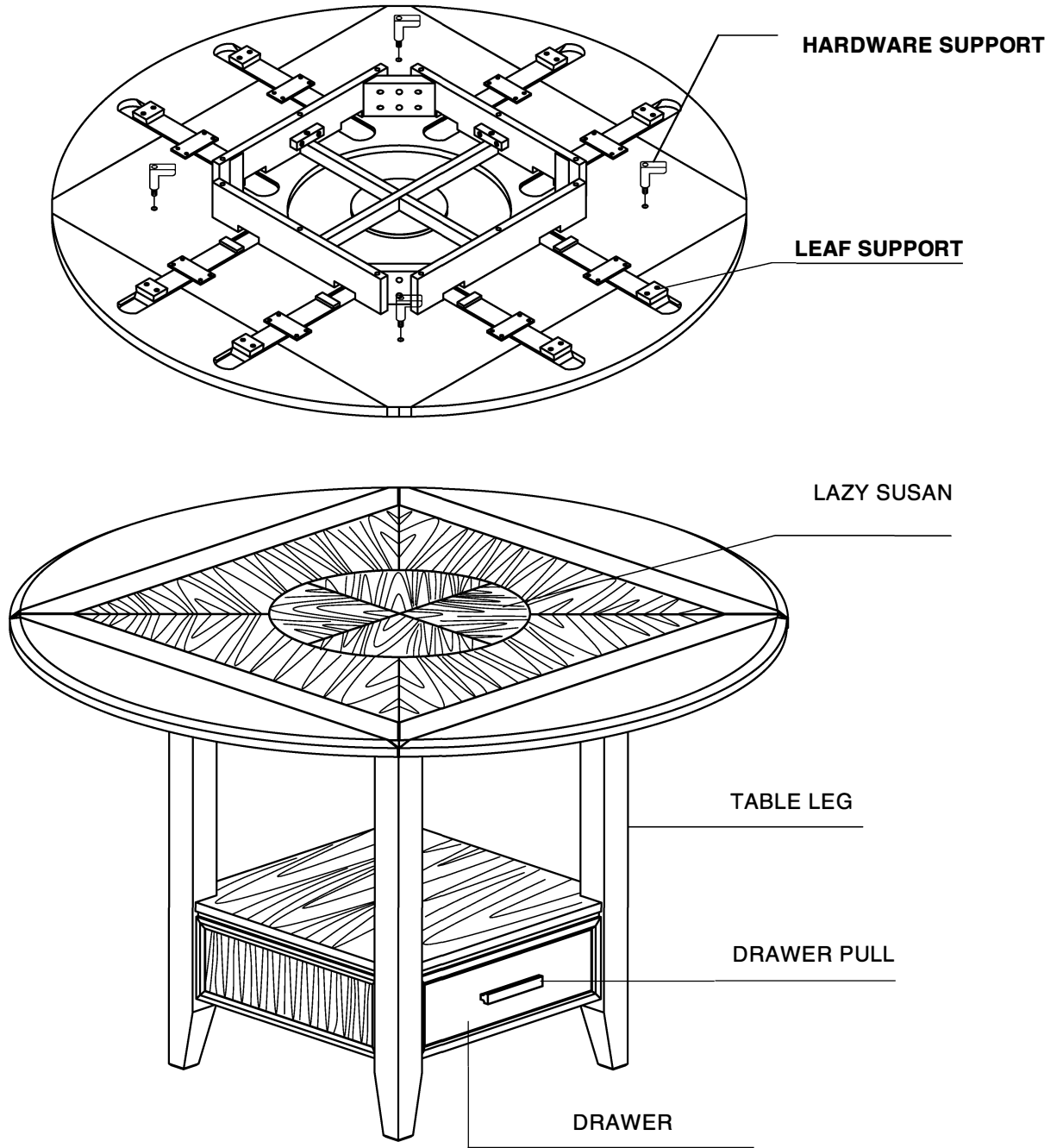

## PRODUCT DETAILS

TOP	MDF VENEER
APRON	RUBBER WOOD
LEG	RUBBER WOOD
LAZY SUSAN	P.B+V3
PRODUCT SIZE (CU200PT/CU200PTB)	59" x 59" x 36"H
CARTON SIZE (CU200PT)	45-7/8" x 45-7/8" x 6-7/8"
CARTON SIZE (CU200PTB)	27-3/8" x 27-3/8" x 9-1/2"
NET WEIGHT (CU200PT)	100.3 LBS
NET WEIGHT (CU200PTB)	28.66 LBS
GROSS WEIGHT (CU200PT/CU200PTB)	111.3 LBS / 33.1 LBS
CU.FT. (CU200PT/CU200PTB)	8.38' / 4.1'

## Counter Chair

Product size : 19" x 22.5" x 43"H

Your furniture purchase is an investment. Here are a few tips to maximize the lifetime of your furniture with a minimum amount of effort. Properly caring for your furniture can help ensure that it looks great year after year.

### Wood Furniture Maintenance:

- Always dust, wipe, and clean *with* the grain of the wood.
- Dust with a soft cloth. Dust will scratch the furniture surface if not removed properly.
- Use the same type of polish consistently as interchanging oil-based and wax-based polishes will cause a build-up and result in a foggy or cloudy appearance.
- If a polished surface becomes foggy, rub it with a cloth dipped in a solution of one tablespoon vinegar to one quart of water. Rub softly with the grain until the surface is completely dry.
- Soap and water are not advisable for wood surfaces. Water can penetrate the finish and raise the grain on wood, causing damage.
- Remember to change dusting cloths frequently as dirty cloths may scratch your furniture's surface.

### The Enemies of Wood:

- Moisture is wood's worst enemy. Liquid spills should be gently wiped up immediately. Coasters should be used under all beverages.
- Do not allow rubber or vinyl materials to lie on the furniture. Chemicals in rubber may leave a stain. Put a strip of felt or leather under accessories that have rubber or vinyl.
- Heat creates a chemical change in the furniture's finish, which results in a white spot. Use protective pads under hot dishes, appliances, etc.
- Sunlight's ultraviolet rays can damage the finish of furniture. Do not place furniture directly against a heater or radiator and do not place in the path of hot streams of air from central heating. This will cause extreme localized drying of the wood.

### High Gloss Resin Table Maintenance:

- Resin tabletops have approximately 1/8" of a resin coat on the top face of the table, which will resist ice, water, wine, liquor, food, cleaning fluids, and warm or hot liquids; however, cups, glasses, etc. containing hot liquids should not be left on the table without a coaster for protection.
- Resin tabletops will scratch just the same as any other glossy surface and basic precautions should be taken.
- For lasting shine, the resin table should be waxed with a car wax that does not contain silicon. Maintaining this wax build-up will result in a high gloss shine.
- When wiping down the table, a soft, clean rag should be used. Do not use a heavy paper.

### Granite Top Maintenance:

The surface of the granite on your table has been polished or sealed to create a generally non-porous surface. The stone has many natural characteristics including: veining, hairline cracks, and color variations - which make up the stone's beauty.

To maintain the beauty of your granite:

- Protect surfaces from scratching, staining and etching by:
    - \* Keeping them free of debris or sharp objects
    - \* Wiping up spills immediately
    - \* Avoiding contact with chemicals (particularly acid-based materials)
  - Clean with pH neutral products or those especially formulated for use on stone.
  - It is not recommended to use a water-based solvent for dark granite as it will remove the polish from the surface.
  - After a period of use, apply a penetrating sealer to prevent contaminants from being absorbed into the stone.
  - Remove stains with special absorbent poultices formulated for use on stone.
  - Renew the surface on polished granite (granite with a high gloss surface) by buffing with special stone polish, powder or cream.
- Do not use granite polish on granite with a matte finish, which has been honed rather than polished. (Penetrating sealer may be used on both polished and honed granite.)

### Marble Top Maintenance:

Marble may be stone, but it is porous stone and can stain easily. Treating marble surfaces the same as wood surfaces is a great rule of thumb.

- It is recommended to seal the tops on a regular basis (every 6 to 12 months). A good quality stone sealer can be purchased from any tiles/stone store or any homecare store and should be applied according to the manufacturer's recommendation.
- When sealed properly, marble tops can be used indoors and outdoors and can withstand any weather conditions except internal freezing. Snow or freezing rain will penetrate the table and cause cracks.

### Caring for the Fabric on Upholstered Furniture:

- Frequent vacuuming of the entire upholstered area will prevent dust from settling into the fibers.
- Professional cleaning is always recommended for all upholstered pieces.
- Always pre-test a small area of fabric in an inconspicuous area when cleaning before proceeding.
- Do not use cleaning products containing brightening agents.

# VERY IMPORTANT!!

<p><b>NEVER</b> USE GLASS CLEANERS ON FINISHED SURFACES. AMMONIA WILL CHEMICALLY ATTACK THE FINISH.</p>	<p>DO NOT WRITE DIRECTLY ON SURFACE </p> <p><b>PREVENT MARKING</b></p>	<p>DO NOT PLACE DIRECTLY IN SUNLIGHT </p> <p><b>PREVENT FADING</b></p>	<p>DO NOT USE PLACEMATS WITH RUBBER BASES </p> <p><b>PREVENT DISCOLORING</b></p>
<p><b>NEVER</b> ALLOW LIQUIDS OF ANY KIND TO LINGER ON SURFACES. ABSORPTION CAUSES THE WOOD TO WARP AND THE FINISH TO DE-LAMINATE.</p>	<p>DO NOT USE COMMERCIAL POLISHES AND WAXES </p> <p><b>PREVENT YELLOWING</b></p>	<p>DO NOT PLACE HOT POTS, ETC. ON SURFACE </p> <p><b>PREVENT DAMAGE TO FINISH</b></p>	<p>REGULATE THE HUMIDITY CONDITIONS AT YOUR HOME </p> <p><b>PREVENT SPLITTING</b></p>

# ASSEMBLY INSTRUCTIONS

DO NOT FULLY TIGHTEN SCREWS AND BOLTS UNTIL THE ENTIRE ITEM IS COMPLETELY ASSEMBLED

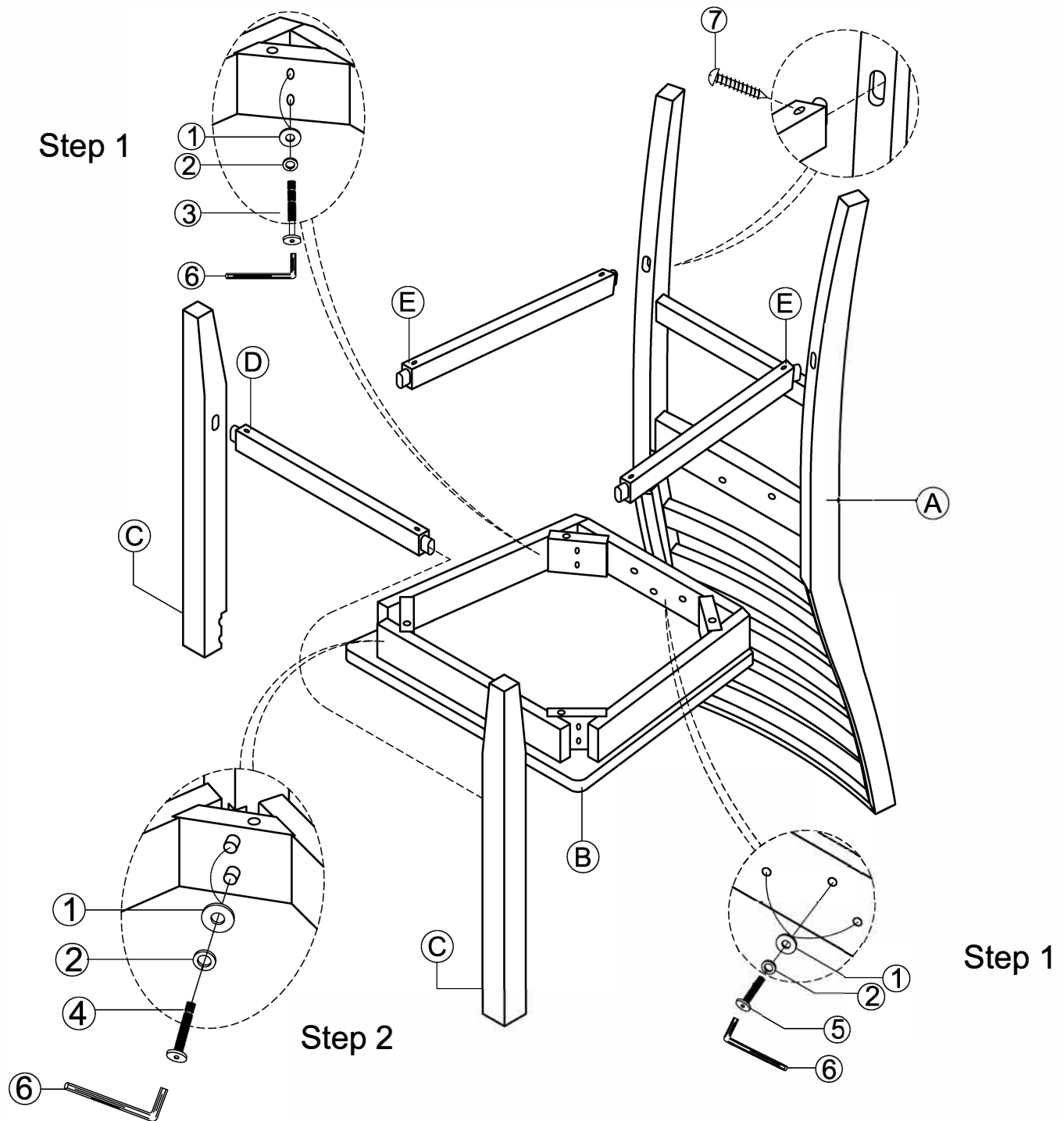

## + STEP 1:

- Turn chair back (A) upside down.
- Attach seat box with wood seat (B) to chair back (A) by using flat washer (1), lock washer (2) and long bolt (3) into the holes at the corner and insert flat washer (1), lock washer (2), short bolt (5) into the holes at the rear bar of seat frame. Tighten the bolts with allen key (6).
- Do not fully tighten the bolts at this stage.





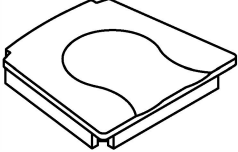
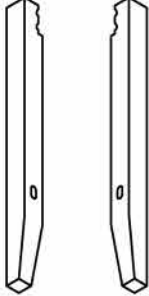
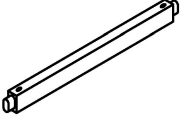
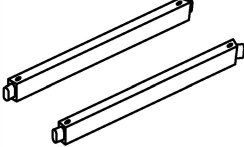

## + STEP 2:

- Insert side stretchers (E) into the holes of rear legs, front stretcher (D) into the holes of front legs (C).
- Attach front leg assembly to side stretchers and corner of the seat frame.
- Secure all stretchers with wood screws (7) by using philips-head screwdriver (not provided).
- Insert flat washer (1) lock washer (2) and middle bolt (4) into the front leg (C).
- Fully tighten all bolts with allen key (6) after leveling the chair.

# PARTS LIST

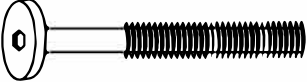
(A) CHAIR BACK (1PC)	(B) SEAT BOX WITH WOOD SEAT (1PC)	(C) FRONT LEG (2PCS)	(D) FRONT STRETCHER (1PC)	(E) SIDE STRETCHER (2PCS)
				

## HARDWARE PACK

NO.	DESCRIPTION		DIMENSION	Q'TY
1	FLAT WASHER		φ5/16" x 19mm	11pcs
2	LOCK WASHER		φ5/16" x 12	11pcs
3	LONG BOLTS		φ1/4" x 85mm	4pcs
4	MIDDLE BOLTS		φ1/4" x 65mm	4pcs
5	SHORT BOLTS		φ1/4" x 42mm	3pcs
6	ALLEN KEY		NO.4	1pc
7	WOOD SCREW		φ8 x 50mm	6pcs

# PARTS FOR COMPLETE HARDWARE

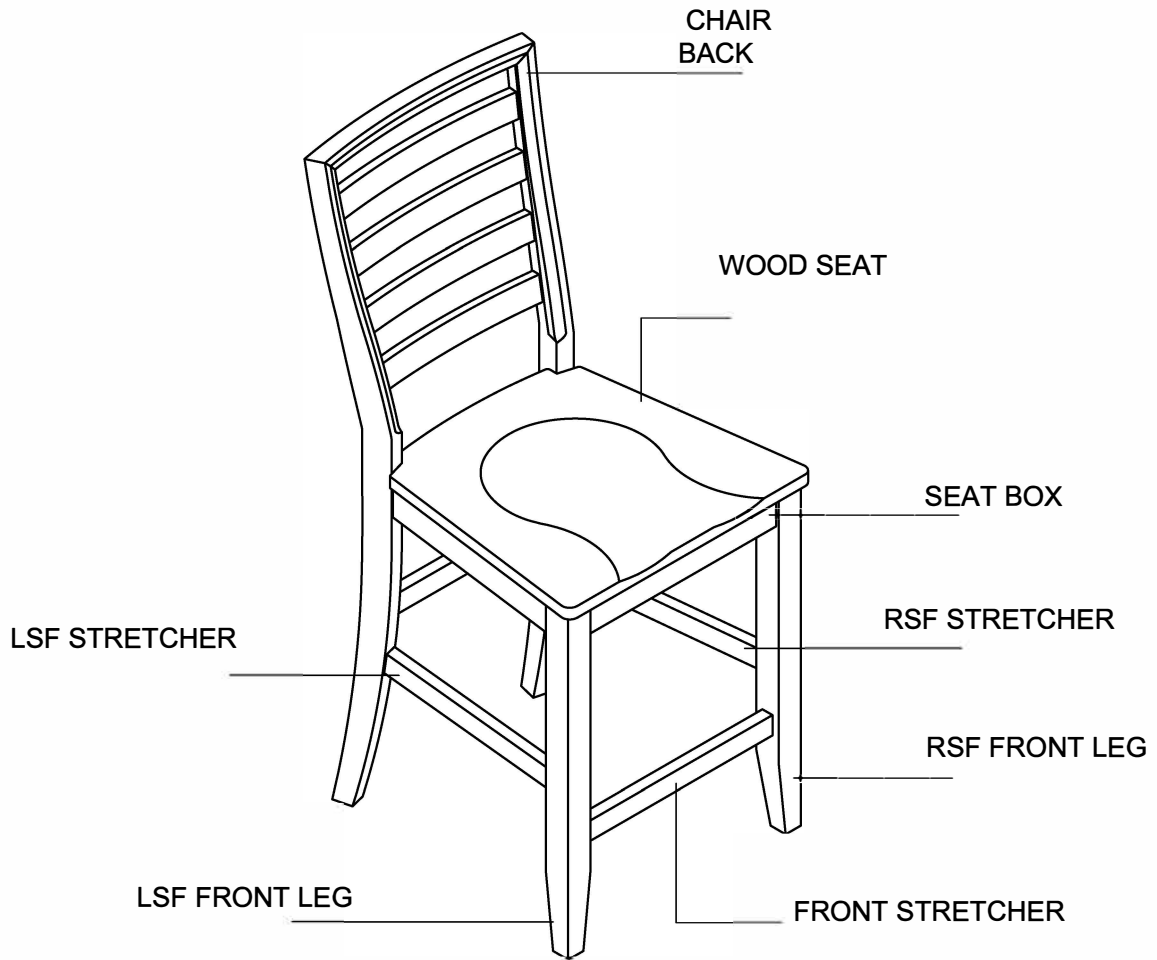

FABRIC CONTENT: POLYESTER 100%  
 This fabric is not machine washable.  
 Allow +/-3% residual shrinkage.  
 Do not use cleaning products containing brightening agents.

Do not mix fabrics of different colors.  
 The fabric is suitable for drapery and upholstery.



PRODUCT DETAILS	
SEAT BOX	ACASIAWOOD
CHAIR BACK	RUBBER WOOD+PLYWOOD
LEG	RUBBER WOOD
STRETCHER	RUBBER WOOD
PRODUCT SIZE	19" x 22.5" x 43"H
CARTON SIZE	45.28" x 19.49" x 11.22"
NET WEIGHT	44.1 LBS
GROSS WEIGHT	48.5 LBS
CU.FT.	5.6"

# Dining Chairs - Assembly

## Troubleshooting Guide

The most important element of correct chair assembly is to tighten the bolts as directed. Prematurely tightening the bolts can lead to numerous issues and will lengthen the assembly time. Listed below are the most common issues in chair assembly and their easy solutions.

### **PROBLEM:** Chair is unlevel.

#### **Cause 1:**

Unlevel chairs can occur if the bolts are fully tightened before all bolts are attached. There is a variance in the alignment of this chair to allow the chair to be assembled more easily.

#### **Solution:**

Loosen each bolt in the seat box (front legs, back corner blocks and back apron) until they are finger tight. Place the chair upright on the floor. Sit in the chair for about 30 seconds. Carefully turn the chair upside down and tighten each bolt. The chair will now be level.

#### **Cause 2:**

Unlevel chairs can occur if one or more of the floor glides are missing from the bottom of the chair leg.

#### **Solution:**

Request a set of floor glides from the e-mail address below.

### **PROBLEM:** Bolts do not fit properly.

#### **Cause:**

This issue can occur when the bolts are tightened fully before all bolts are attached. There is a variance in the alignment of the bolts to allow the chair to be assembled more easily. Tightening the bolts prematurely can cause the holes for the other bolts to become slightly misaligned, causing the remaining bolts not to fit properly.

#### **Solution:**

Make sure each bolt in the seat box (front legs, back corner blocks and back apron) is loosened until finger tight. This will allow you to realign the holes, and the bolts will not fit properly.