

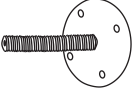
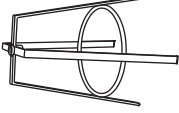
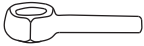
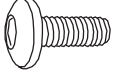

Installation & Assembly

Parts list		Hardware List	
A	1 X Seat		
B	1 X Support Screw Pole		
C	1 X Base		
D	1 X Locker		
E	5 x Bolts	 M6 X 12	
F	1x Flat Washers		
G	1 x Hex Key		

Assembling

Step 1

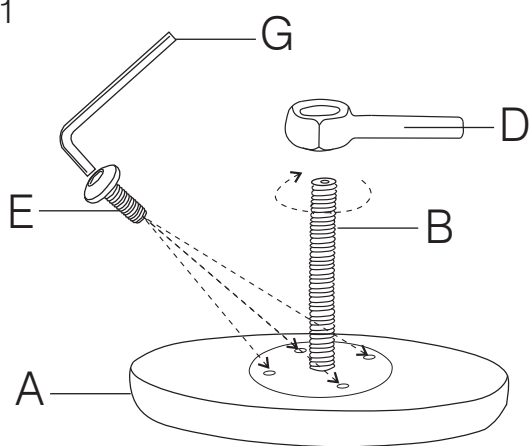

Step 2

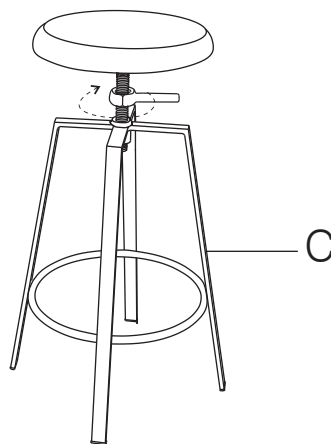

Step 3

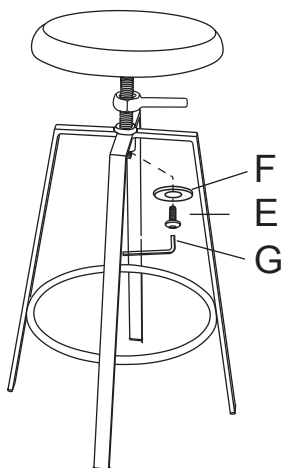

Step 4

