



USER MANUAL

HOGYME

HOGYME

Instruction for Assembly 10' * 12' Metal Shed

Model Number: HGP0793

Missing Parts, Quality Problem, Questions on Assembly?
Email: Hogy.me.service@gmail.com
Request will be replied in 24 hours.

Assembly Preparation

Owner's Manual

Please check local building codes regarding footings, location and other requirements before beginning construction.

Assembly instructions:

Reviewing all instructions and the appropriate information before you begin, make sure following the step sequence carefully for successful results.

Flooring base:

A good location for the storage building is a square and level area with good drainage. The base is not included in the kit which may need purchase separately or may construct a foundation and anchoring system of your own.

A strong plastic sheet (thickness: at least 150µm) should be placed under the foundation to assist in reducing rising dampness from the soil, thus reducing condensation build up in the shed. Your storage building must be anchored to prevent wind damage. Once secured, it is highly recommended applying silicone along the inside of the base rail to minimize condensation.

Parts and Parts List:

Before you start, separate and identify all the parts and hardware to be sure that you have all the necessary parts for your building (refer to the Parts List Page).

If you find that a part is missing, please notify the seller within one week after receiving the product. Do not attempt to assemble the building if parts are missing because any building left partially assembled may be seriously damaged by light winds.

Tools you need:

(Please tear off the safety protection layer before the assembly, keep the part number label if needed)

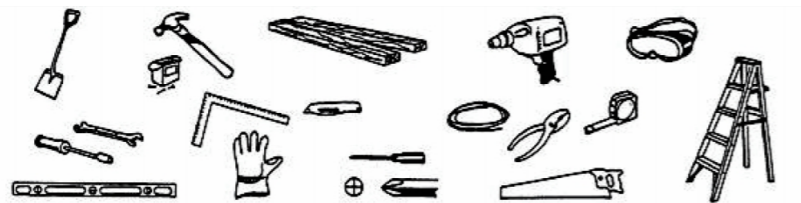

Safety must be put in the No. 1 position:

1. Select a dry and calm day for your assembly. Team works (Two or more people) are required during the assembly. It is also recommended to finish the assembly in a day to avoid damage to the product or missing of some small parts.
2. Wearing safety gloves, eye protection and long sleeves during the assembly to prevent injury. Pay attention to the sharp edge of some parts.
3. Children and pets are not allowed entering into the construction site.
4. Never concentrate your total weight on the roof of the building. When using a step ladder make sure that it is safe.

Care & Maintenance:

1. Keep the shed clean with soft cloth, use water if necessary.
2. Keep the door tracks clear of dirt and other stuff that prevent them from sliding easily.
3. Clean the snow with necessary tools to make sure it is safe to enter into.
4. The shed is not made for living but storing stuff.
5. Please add some oil on the top and bottom door sliding channel to make door slides smoothly.

Size:

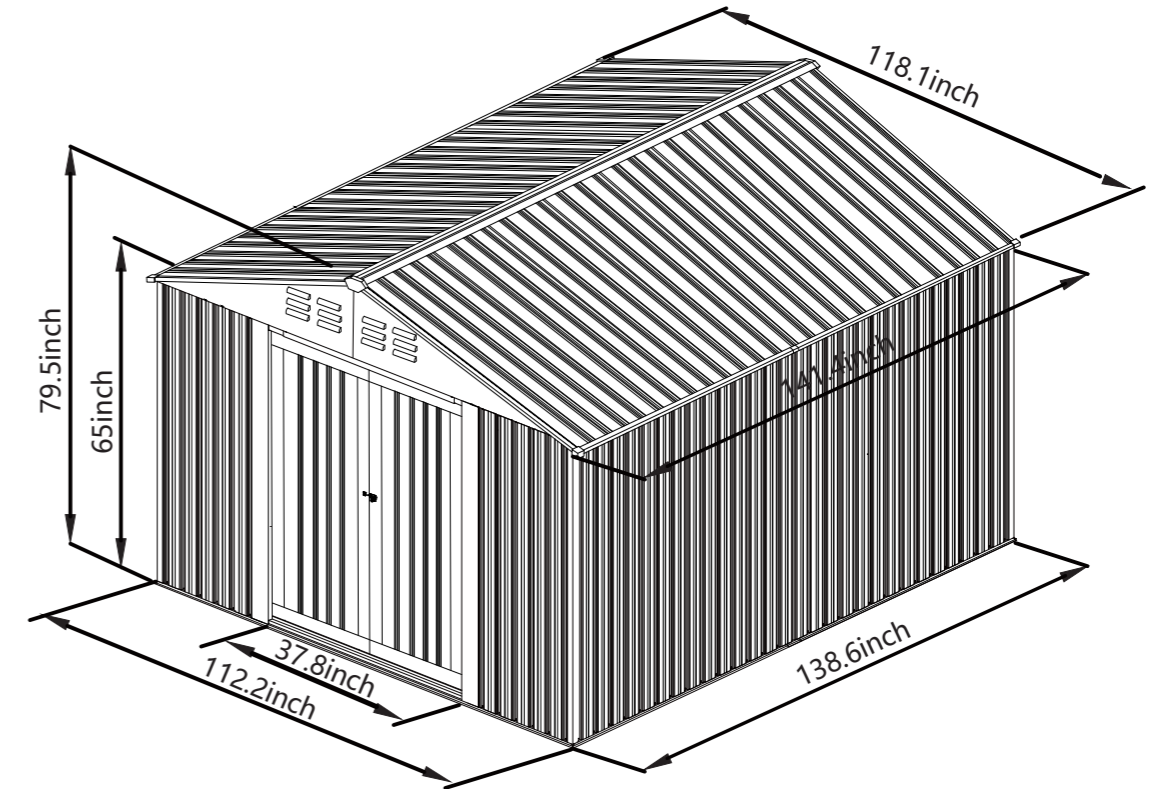

Area of installation requirement:

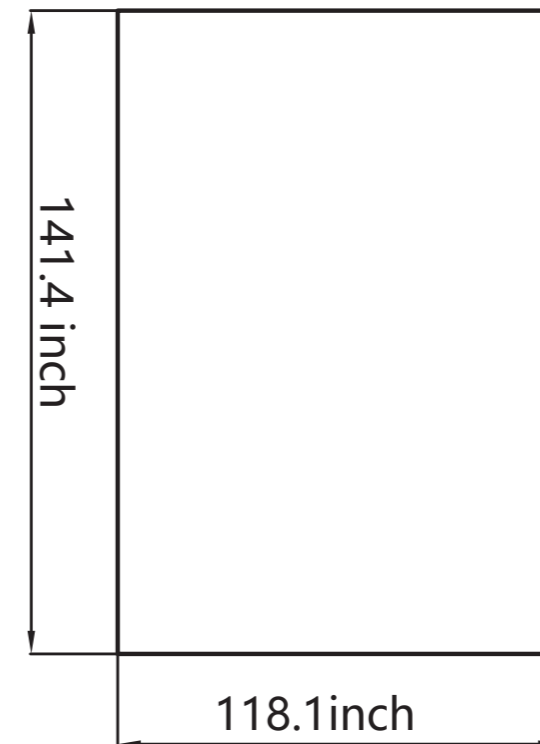

Preparación de Ensamblaje

Manual del Propietario

Antes de comenzar la construcción, verifique los códigos de construcción locales con respecto a los cimientos, la ubicación y otros requisitos.

Instrucciones de Ensamblaje:

Antes de comenzar, revise todas las instrucciones y la información adecuada, asegúrese de seguir cuidadosamente la secuencia de pasos para obtener resultados exitosos.

Base de Piso:

Una buena ubicación para el edificio de almacenamiento es un área cuadrada y nivelada con buen drenaje. La base no está incluida en el kit, que puede necesitar comprarse por separado o puede construir un sistema de cimentación y anclaje propio.

Se debe colocar una lámina de plástico resistente (espesor: al menos 150um) debajo de la base para ayudar a reducir la humedad ascendente del suelo, reduciendo así la acumulación de condensación en el cobertizo. Su edificio de almacenamiento debe estar anclado para evitar daños por viento. Una vez asegurado, se recomienda encarecidamente aplicar silicona a lo largo del interior del riel de la base para minimizar la condensación.

Piezas y Lista de Piezas:

Antes de comenzar, separe e identifique todas las partes y el hardware para asegurarse de que tiene todas las partes necesarias para su construcción (consulte la página de lista de piezas)

Si encuentra que falta una pieza, notifique al vendedor dentro de una semana después de recibir el producto. No intente ensamblar el edificio si faltan piezas porque cualquier edificio dejado parcialmente ensamblado puede ser seriamente dañado por vientos ligeros

Herramientas Que Necesitas:

(Por favor, retire la capa de protección de seguridad antes del ensamblaje, mantenga la etiqueta del número de pieza si es necesario.)

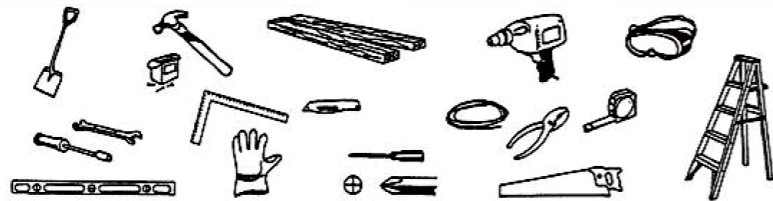

La seguridad debe estar en la posición número uno:

1. Seleccione un día seco y tranquilo para su ensamblaje. Se requiere trabajo en equipo (dos o más personas) durante el ensamblaje. También se recomienda terminar el ensamblaje en un día para evitar daños al producto o la falta de algunas piezas pequeñas.
2. Usar guantes de seguridad, protección ocular y mangas largas durante el ensamblaje para evitar lesiones. Prestar atención al borde afilado de algunas piezas.
3. No se permite la entrada de niños y mascotas al sitio de construcción.
4. Nunca concentres todo tu peso en el techo del edificio.

Atención y Mantenimiento:

1. Mantenga el cobertizo limpio con un paño blando y use agua si es necesario.
2. Mantenga el canal de la puerta libre de suciedad y otras cosas que dificulte el deslizamiento.
3. Limpie la nieve con las herramientas necesarias para garantizar un acceso seguro.
4. Este cobertizo no se utiliza para vivir, sino para almacenar las herramientas.
5. Agregue un poco de aceite a los canales deslizantes de las puertas superior e inferior para que las puertas se deslicen sin problemas.

Medida:

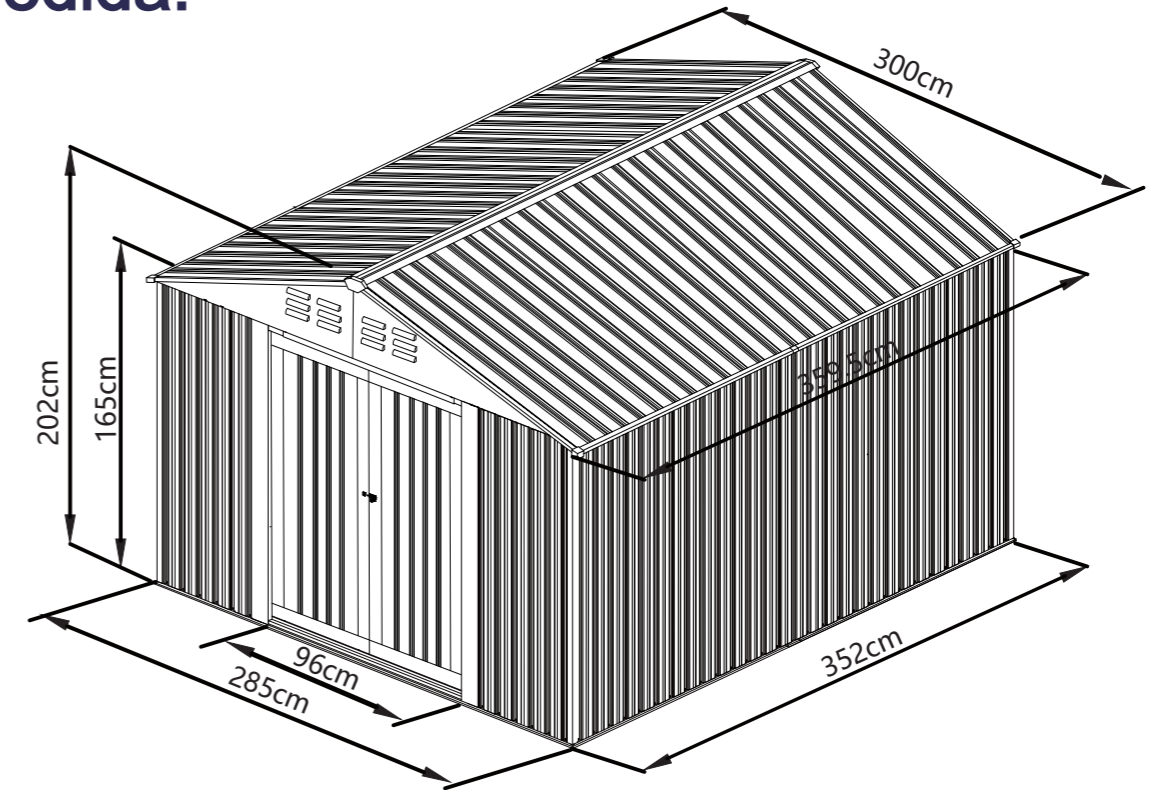



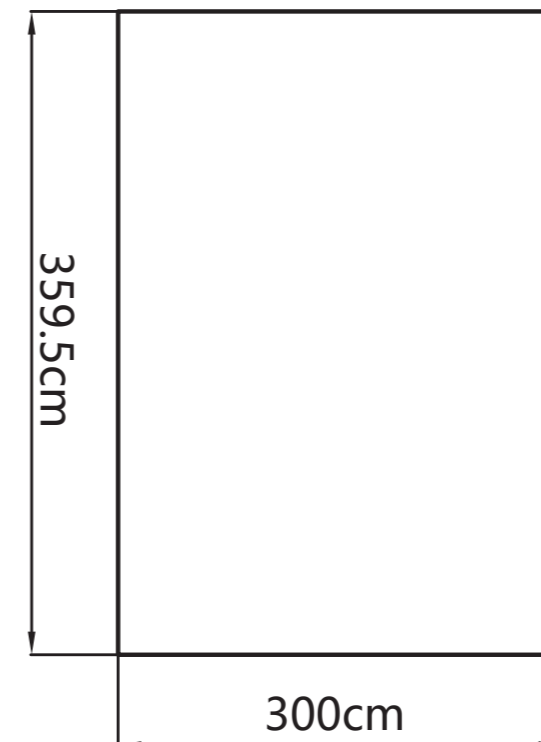

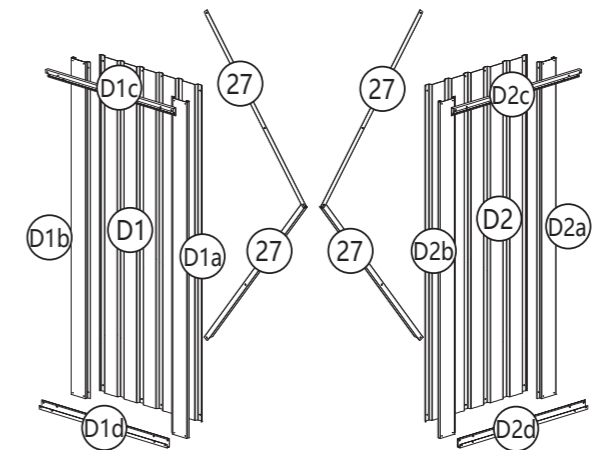
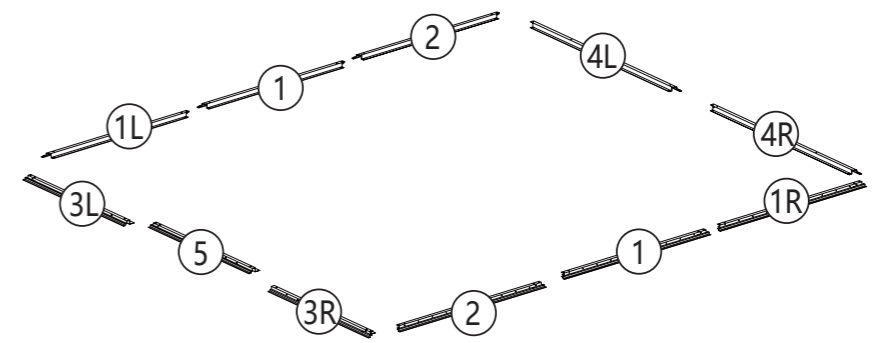
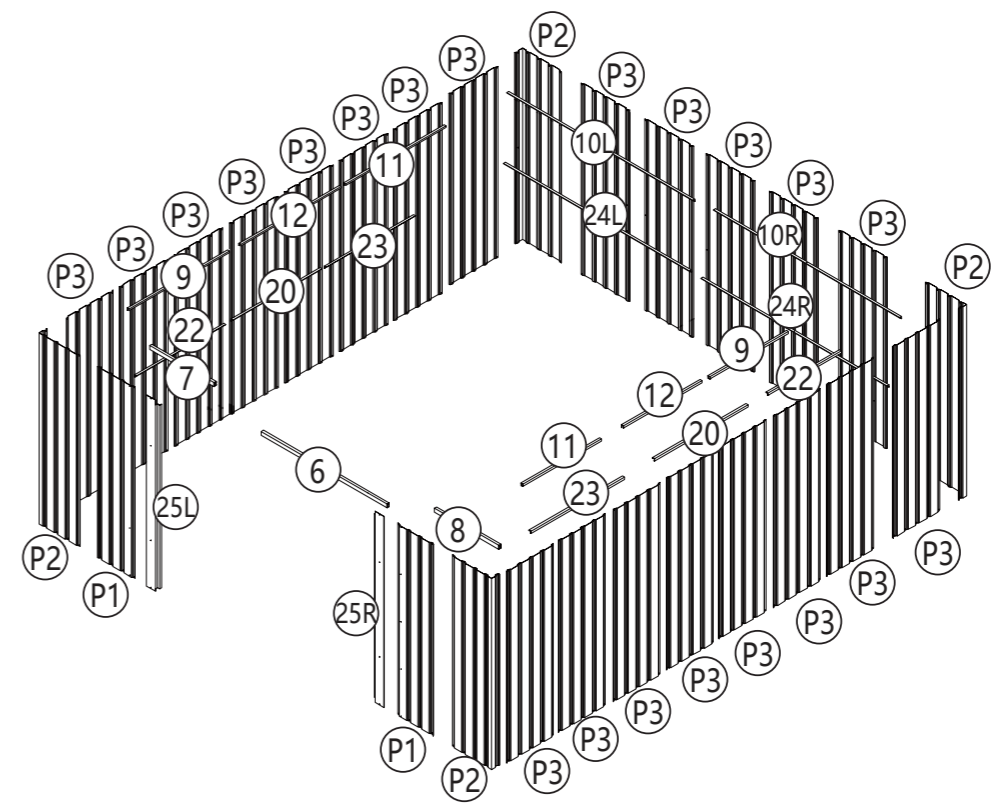
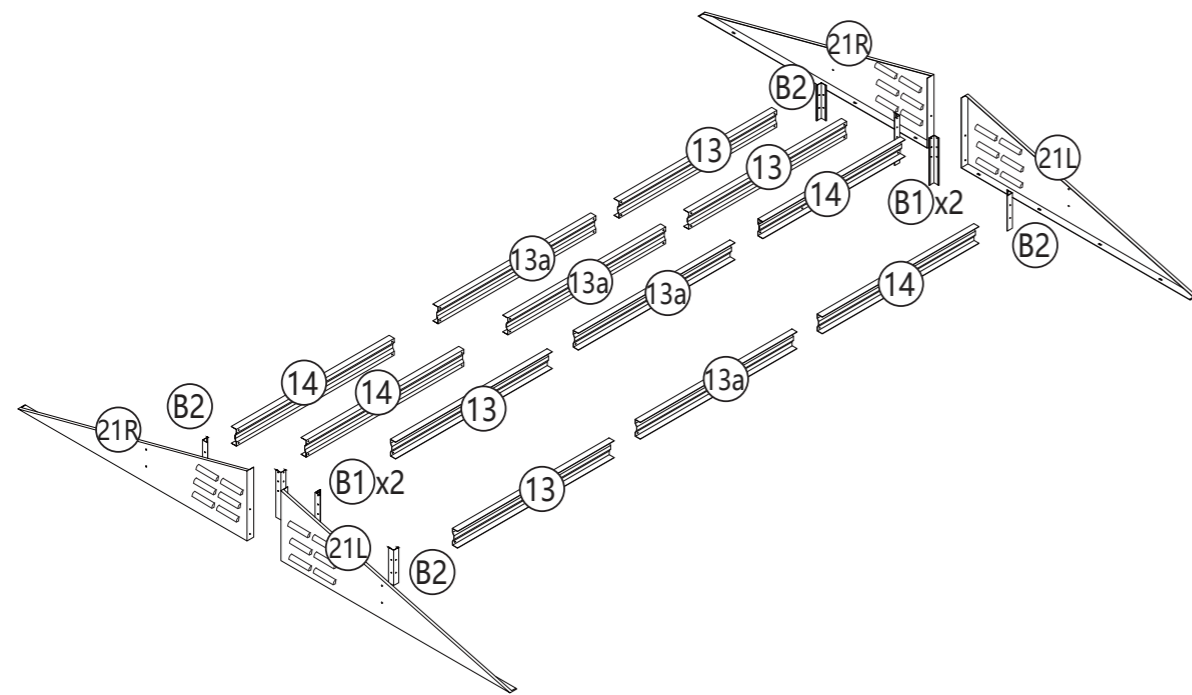
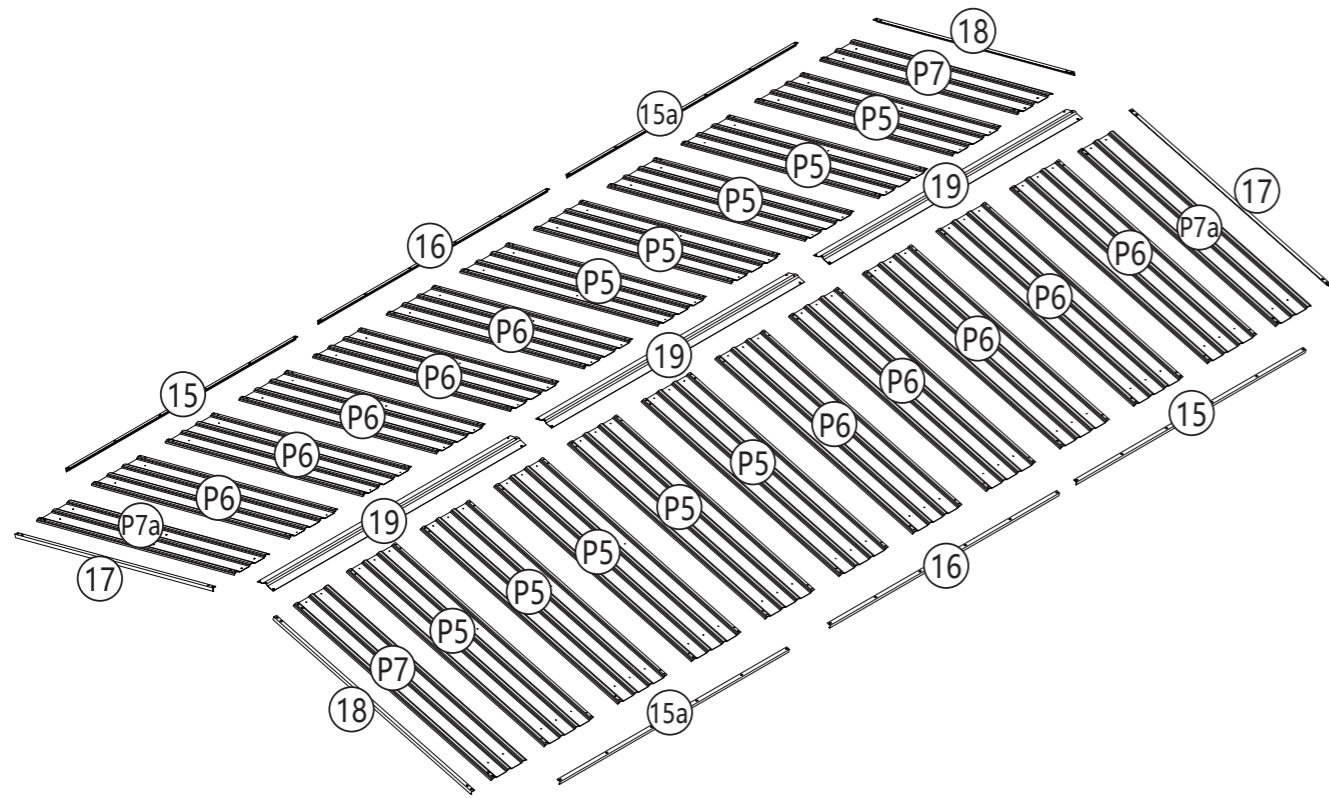

Área de Requisito de Instalación:







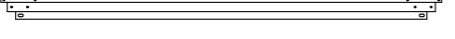
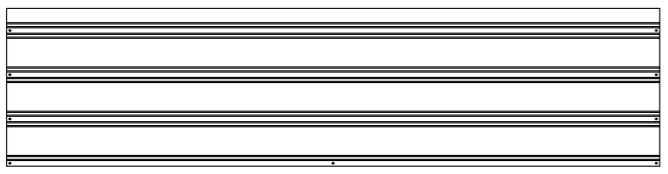
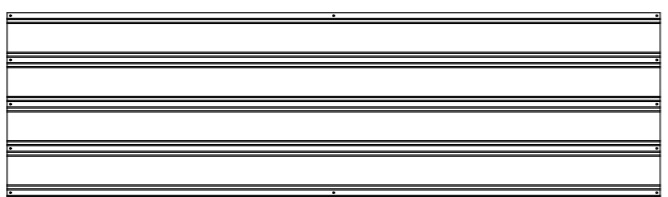
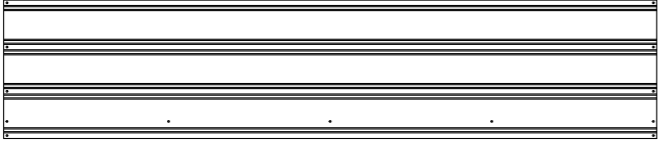











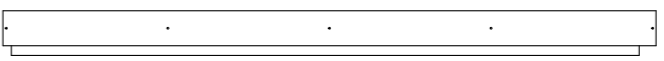
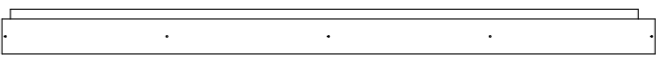
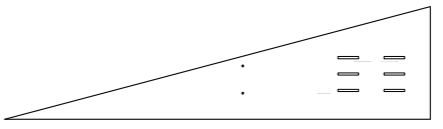
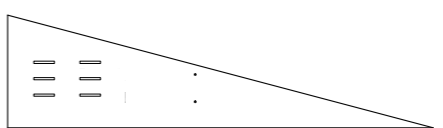
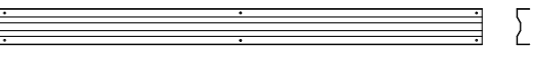



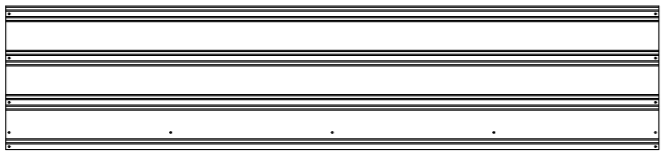
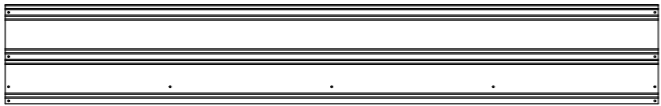



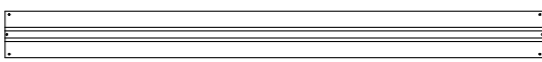





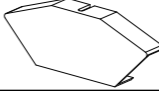
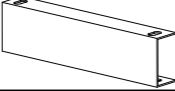

Hardware List

(Lista de Accesorios)

NO. (Número)	IMAGE (Pieza)	QTY (Cantidad)	Box No. (Número de Caja)
UNDER (Debajo)			
1/1L/1R		X2	2/2
		X1	2/2
		X1	2/2
2		X2	2/2
3L/3R		X1	1/2
		X1	1/2
4L/4R		X1	1/2
		X1	1/2
5		X1	1/2
MIDDLE (Medio)			
P2		X4	1/2
P3		X21	2/2
P1		X2	1/2
6		X1	1/2

7		X1	1/2
8		X1	1/2
9		X2	2/2
10L/10R		X1	1/2
		X1	1/2
11/12		X2	2/2
		X2	2/2
20		X2	2/2
22		X2	2/2
23		X2	2/2
24L/24R		X1	2/2
		X1	2/2
25L		X1	1/2
25R		X1	1/2
TOP1 (Techo 1)			
21L		X2	2/2
21R		X2	2/2
13/13a/14		X4	2/2
		X4	2/2
		X4	2/2

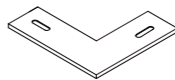
B1		X4	1/2
B2		X4	1/2
TOP2 (Techo 2)			
P5/P6		X10	1/2
		X10	1/2
P7/P7a		X2	1/2
		X2	1/2
15/15a		X2	1/2
		X2	1/2
16		X2	1/2
17/18		X2	1/2
		X2	1/2
19		X3	1/2
DOOR (Puerta)			
D1		X1	2/2
D2		X1	2/2
D1a/D2a		X1	1/2
		X1	1/2
D1b/D2b		X1	1/2
		X1	1/2
D1c/D2c		X1	1/2
		X1	1/2
D1d/D2d		X1	1/2
		X1	1/2
27		X4	1/2

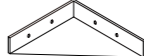
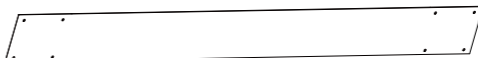
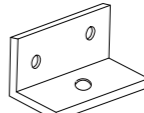
ANNEX (Anexo)			
GC		X4	2/2
GE		X2	2/2
A1		X2	1/2
F1		X521	2/2
F2		X113	2/2
F5		X6	1/2
S1		X426	2/2
F4	 For drilling (Para perforación)	X1	2/2
A3		X4	1/2
Ca3		X1	1/2
Ca1/Ca2		X2	1/2
		X2	1/2
A5		X4	1/2
A6		X3	1/2
A7		X2	1/2

PRODUCT ASSEMBLY (Ensamblaje del Producto)

! Check the package contents before getting started !
 (¡Revisa el contenido del paquete antes de comenzar!)

STEP 1/ Paso 1

3L		X1	3R		X1
5		X1	F1		X8

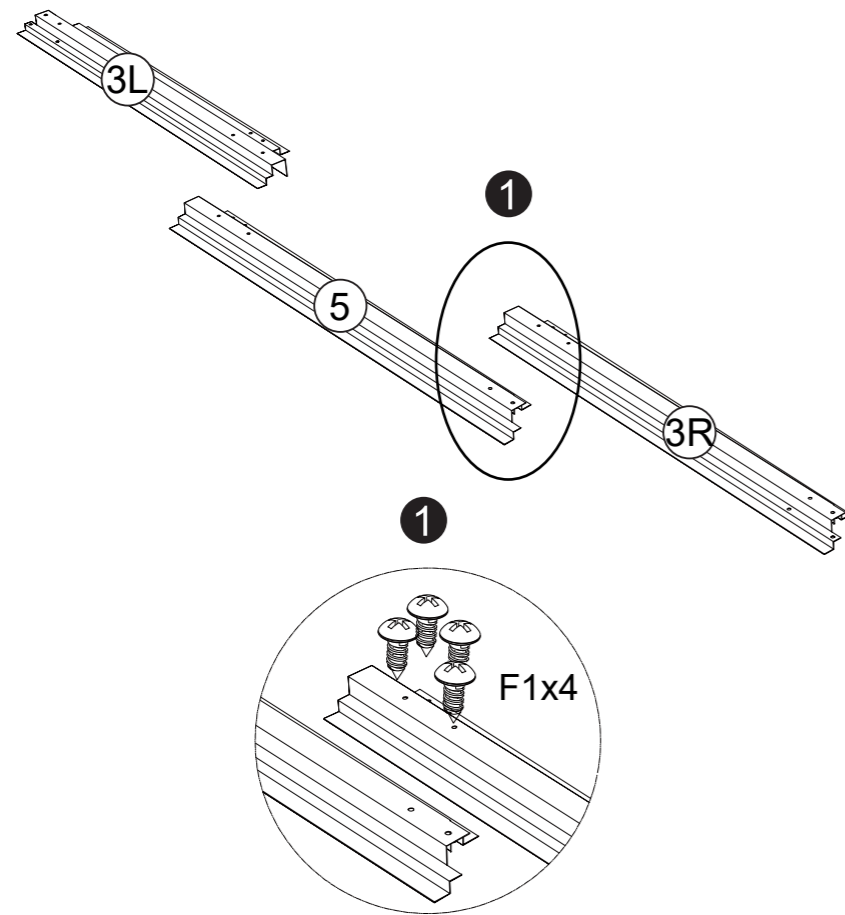



PRODUCT ASSEMBLY (Ensamblaje del Producto)

STEP 2/ Paso 2

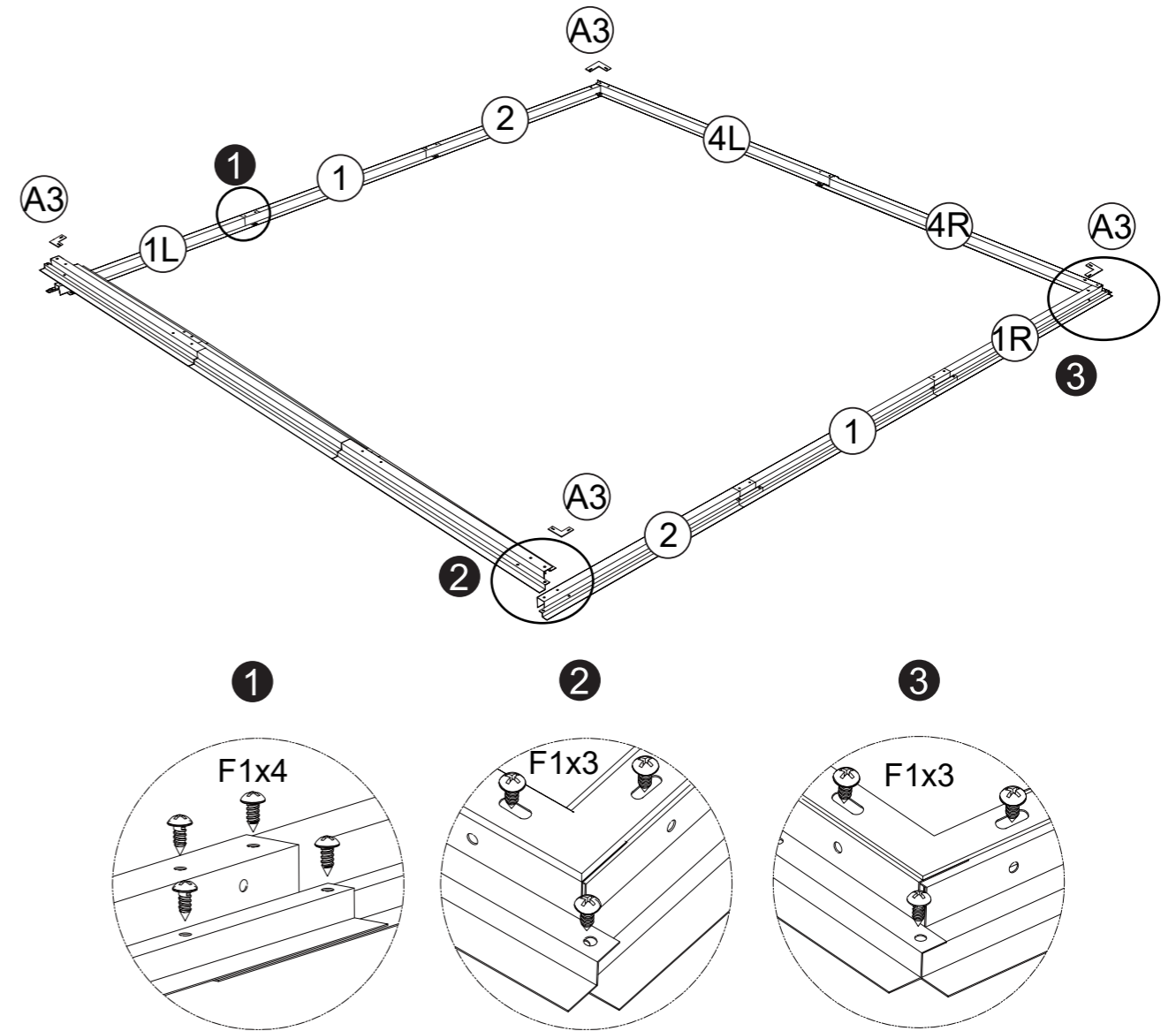
1		X2	1L		X1
1R		X1	2		X2
4L		X1	4R		X1
A3		X4	F1		X32





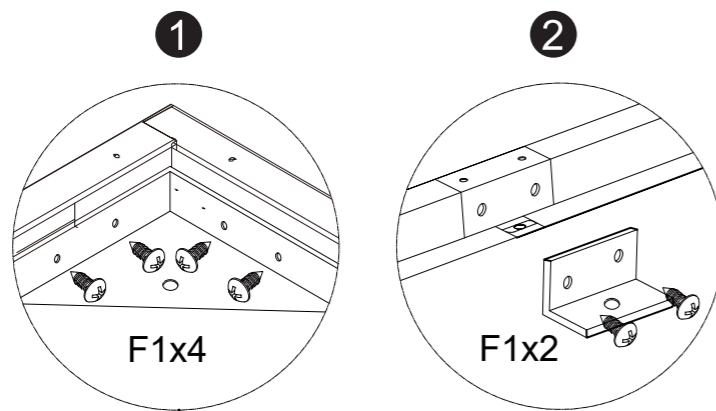
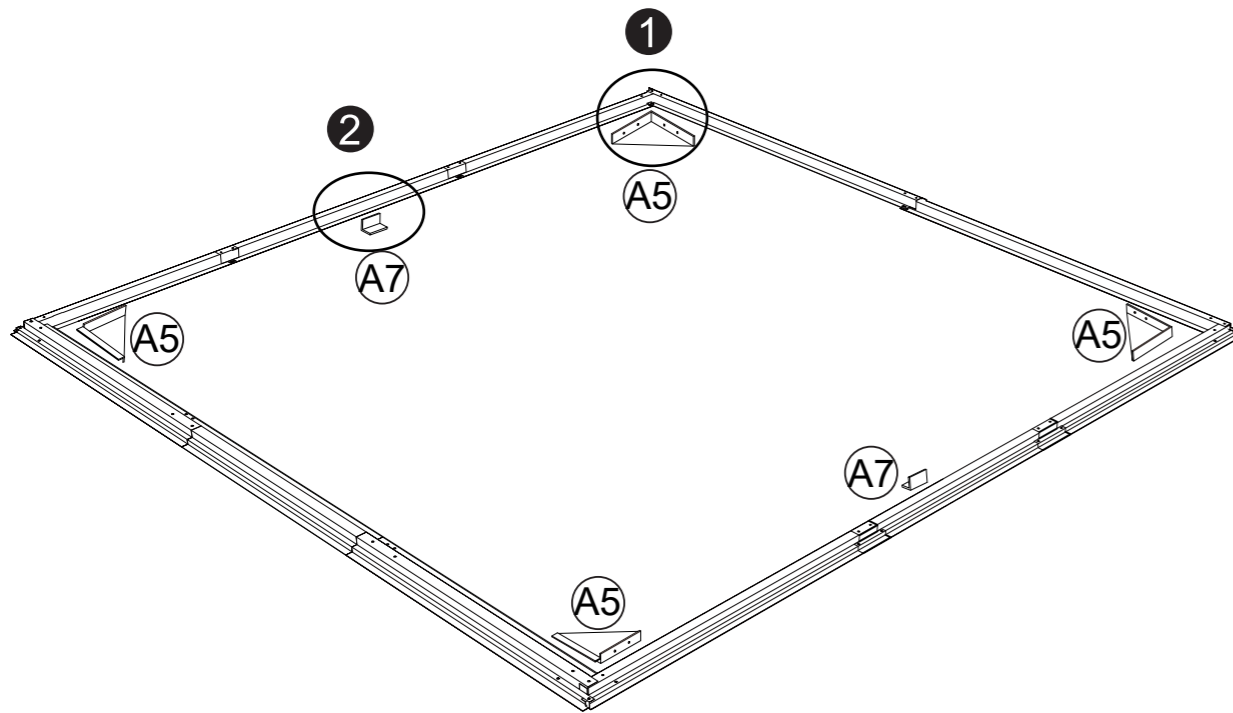

STEP 3/ Paso 3

A5		X4	A7		X2
F1		X20			





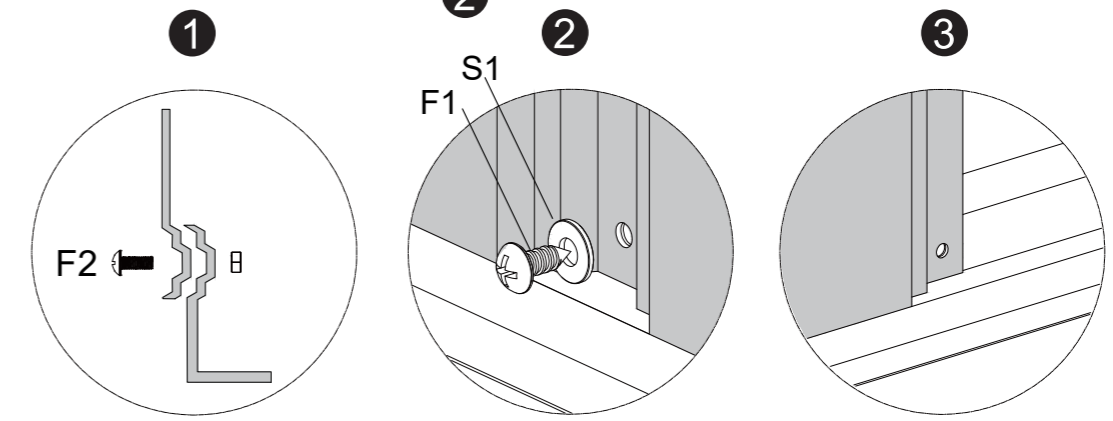
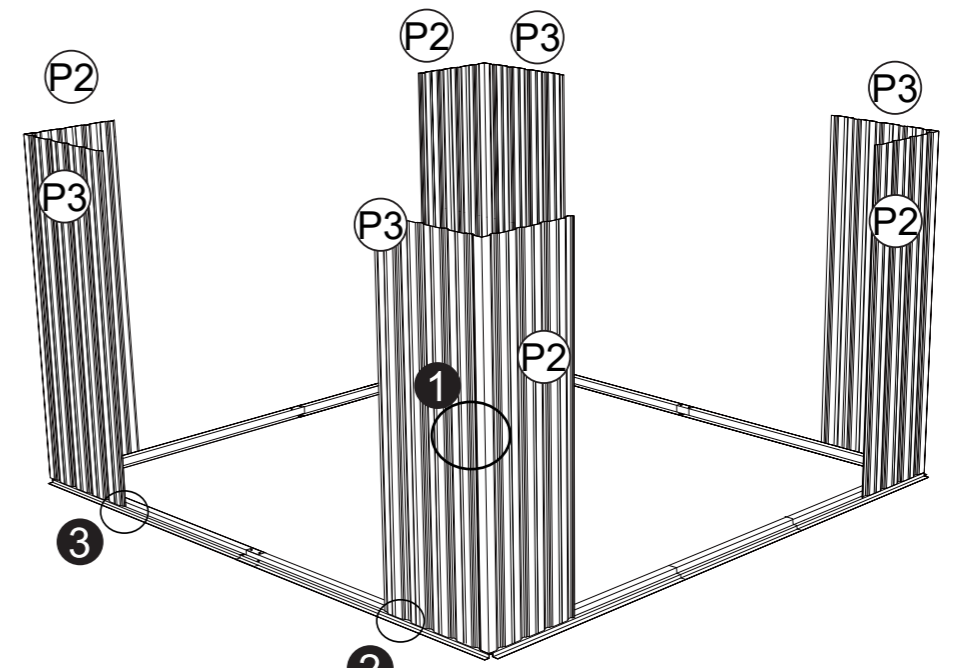

Install one screw on one side of the triangular iron part first, then install the remaining two screws.
 (Primero instale un tornillo en un lado de la parte de hierro triangular, luego instale los dos tornillos restantes.)

STEP 4/ Paso 4

P2		X4	P3		X4
F1		X28	F2		X4
S1		X28			



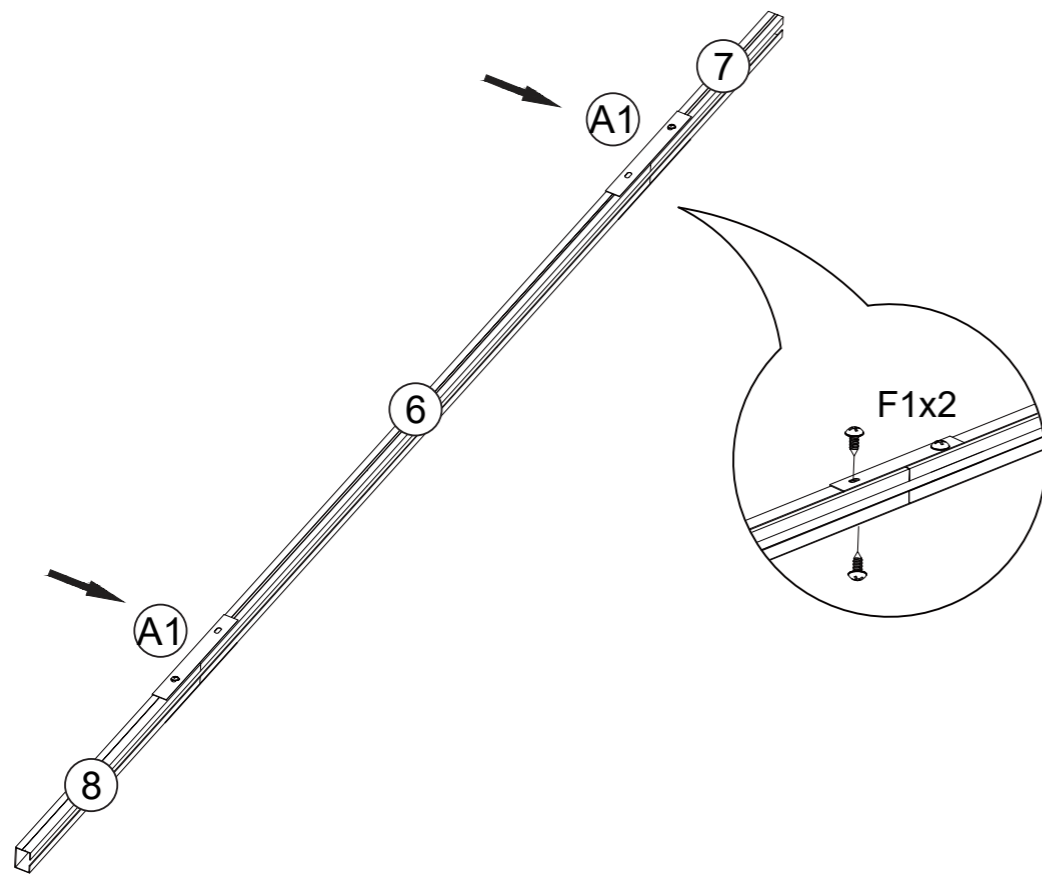

STEP 5/ Paso 5

6		X1	7		X1
8		X1	A1		X2
F1		X4			



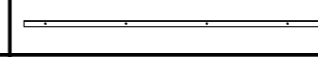
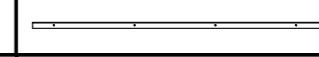
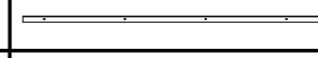
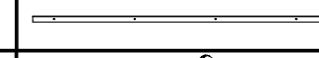
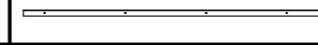

Note: A1 is already pre-installed on 7.8.
 £ Nota: A1 ya está preinstalado en 7.8.£

STEP 6/ Paso 6

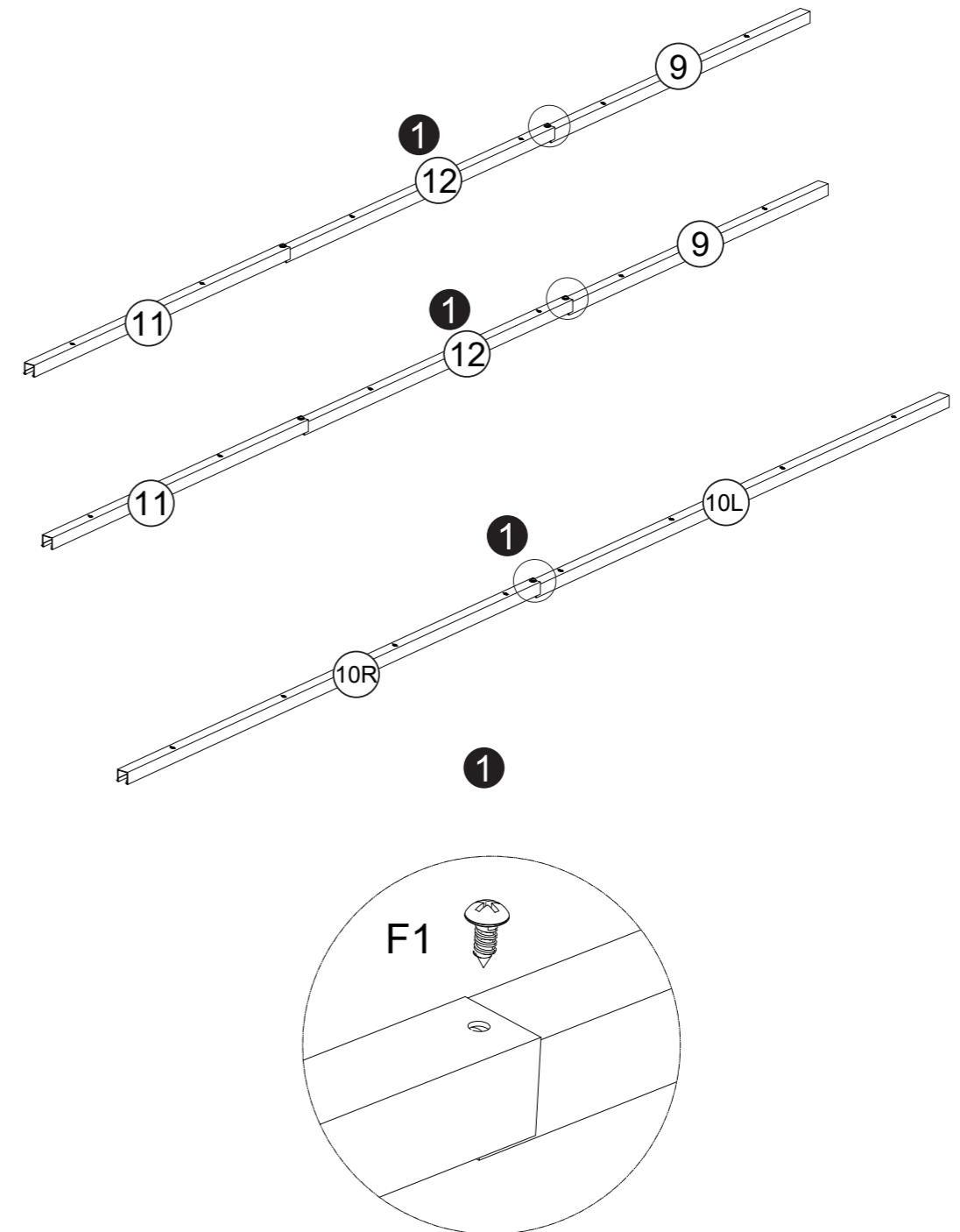
9		X2	10R		X1
10L		X1	11		X2
12		X2	F1		X5



STEP 7 / Paso 7



F1		X28	S1		X28
----	---	-----	----	---	-----

Note: After this step, you need to remove the 4 F2 that hold P2 and P3 in place.

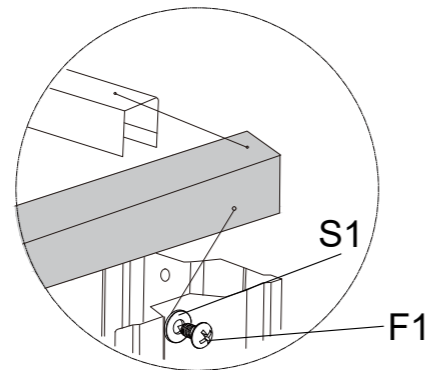
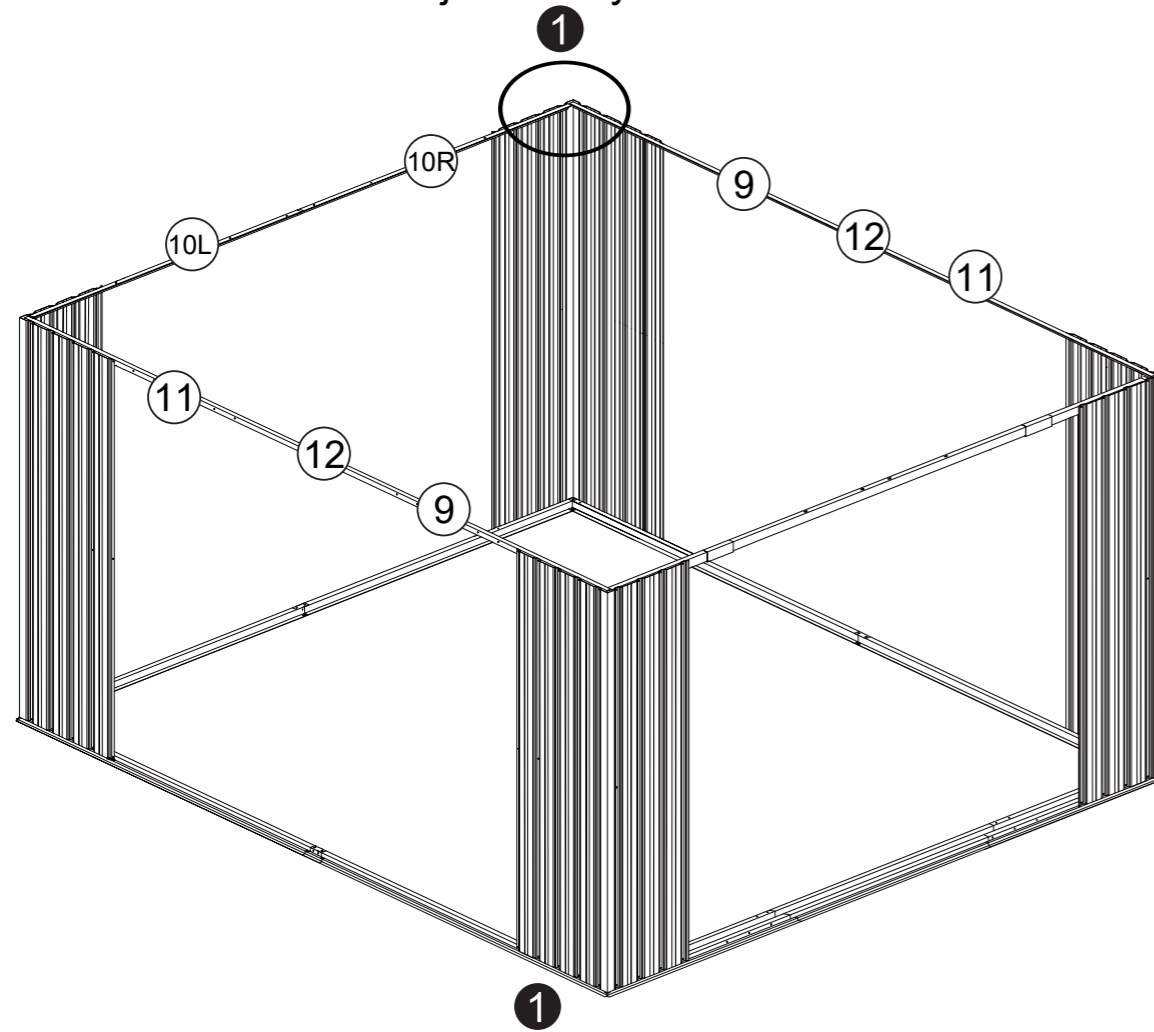
£ Nota: Después de este paso, necesita quitar los 4 F2 que sujetan P2 y P3.£



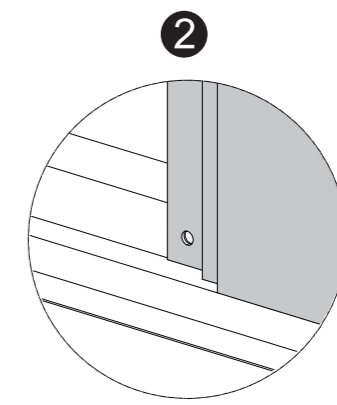
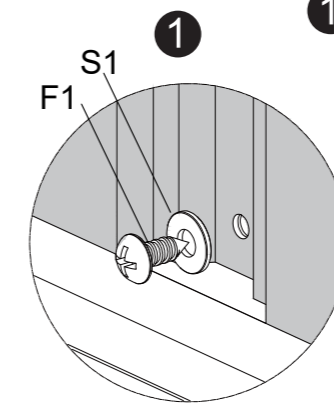
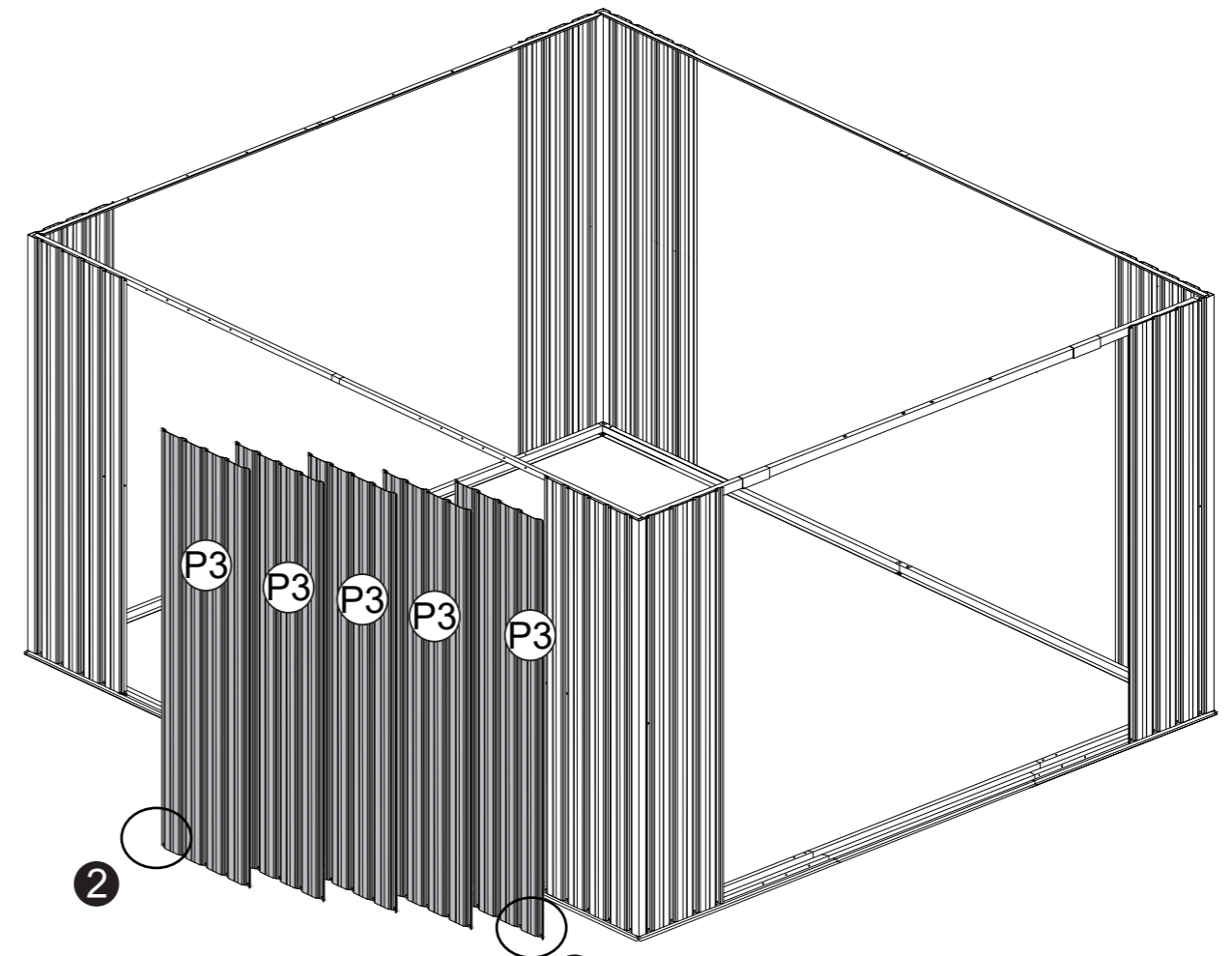

STEP 8 / Paso 8

P3		X5	F1		X40
S1		X40			



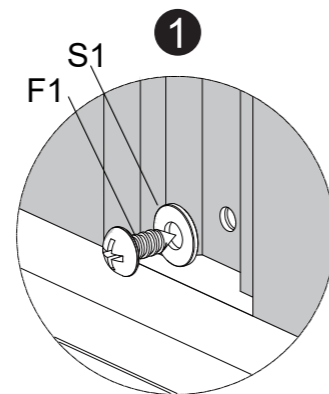
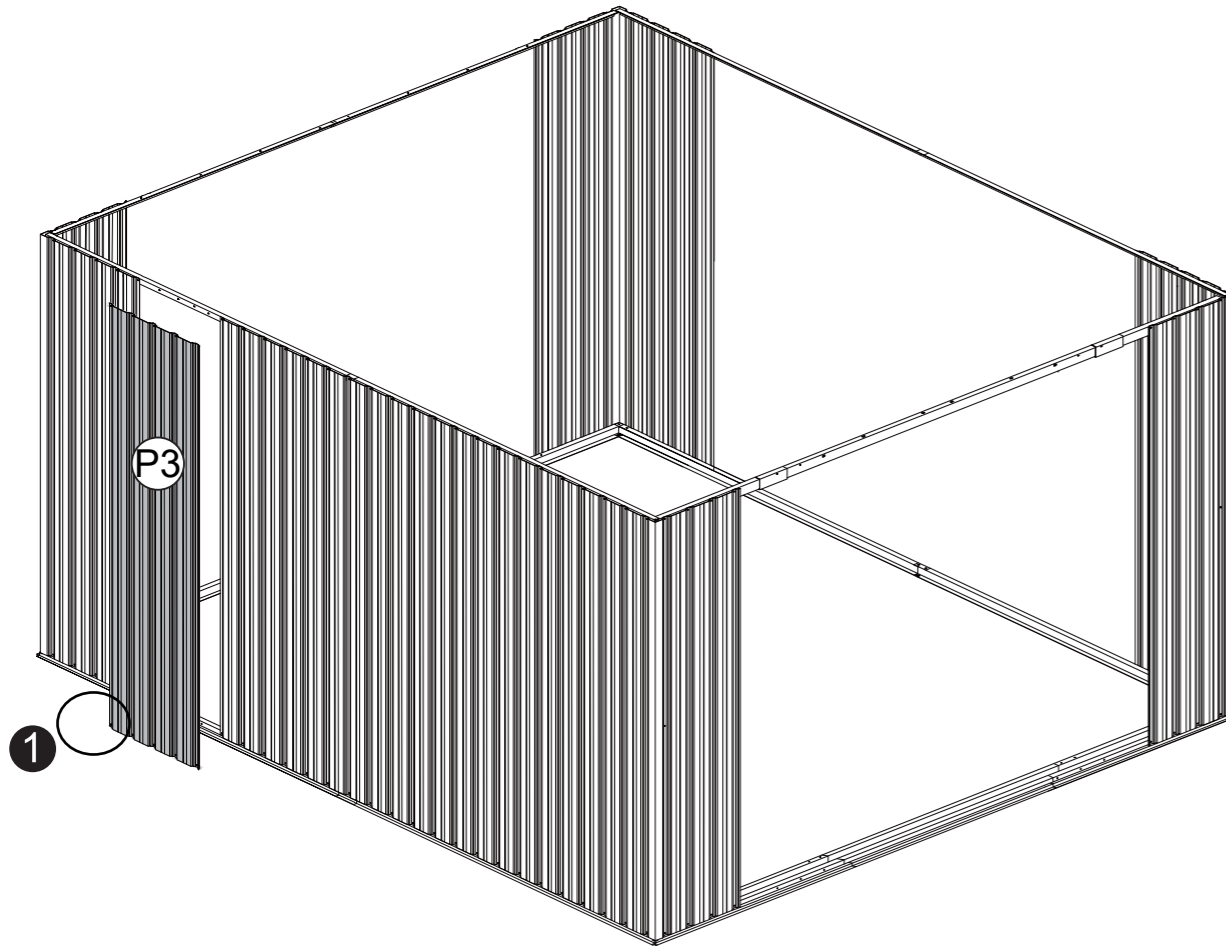

STEP 9/ Paso 9

P3		X1	F1		X5
S1		X5			



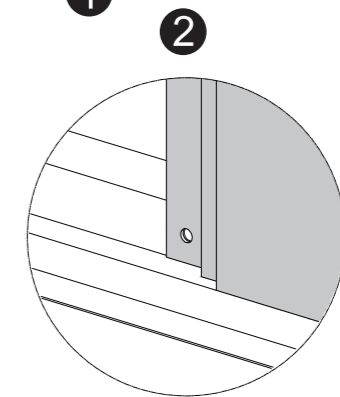
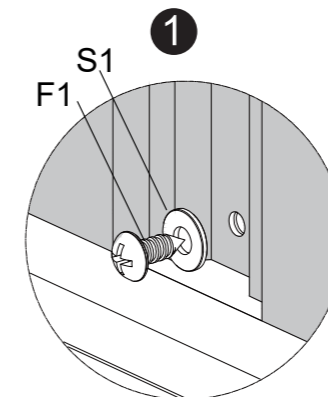
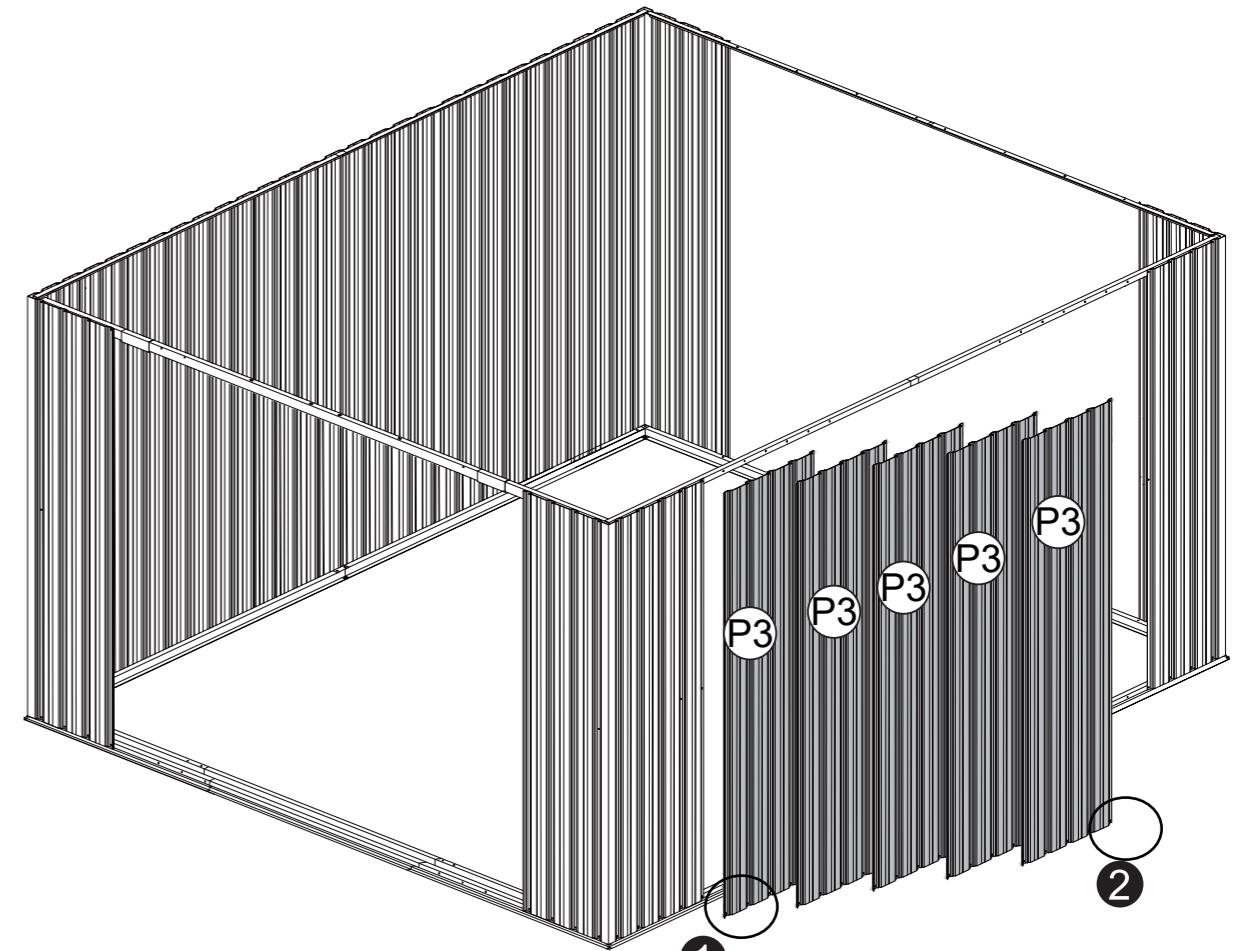

STEP 10/ Paso 10

P3		X5	F1		X40
S1		X40			



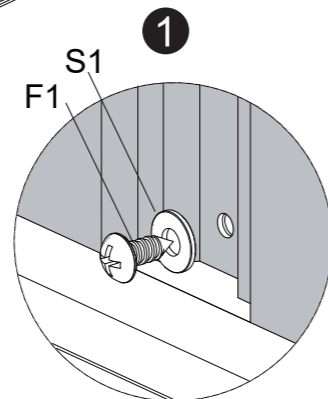
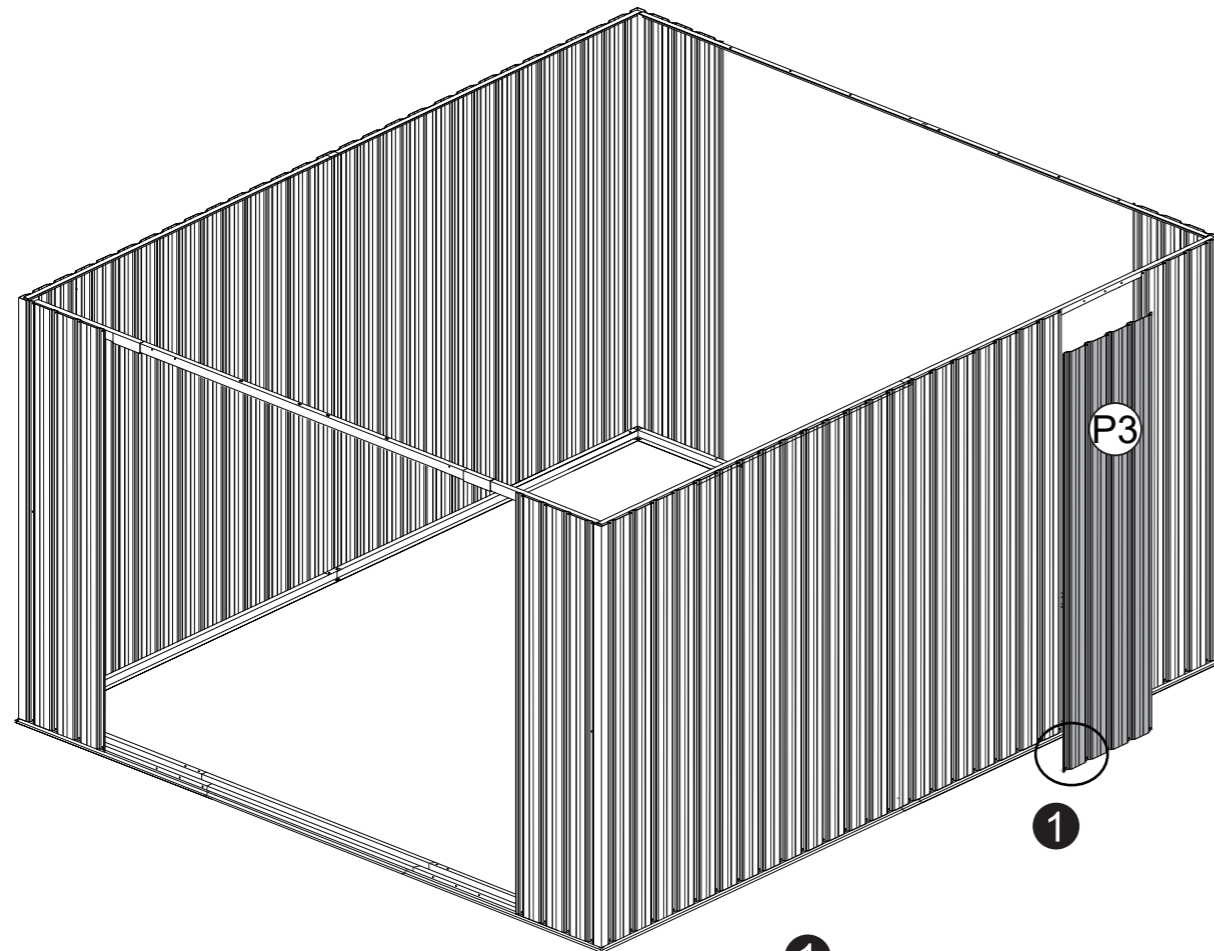

STEP 11/ Paso 11

P3		X1	F1		X5
S1		X5			



STEP 12/ Paso 12

P3		X4	F1		X32
S1		X32			

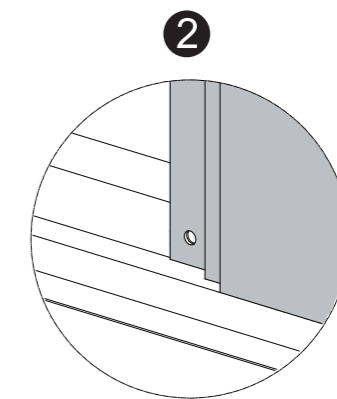
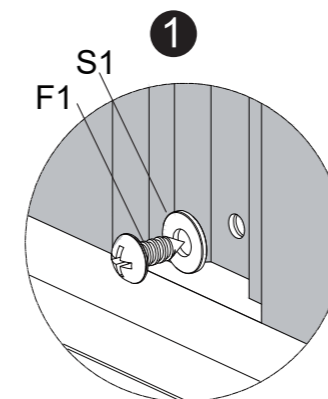
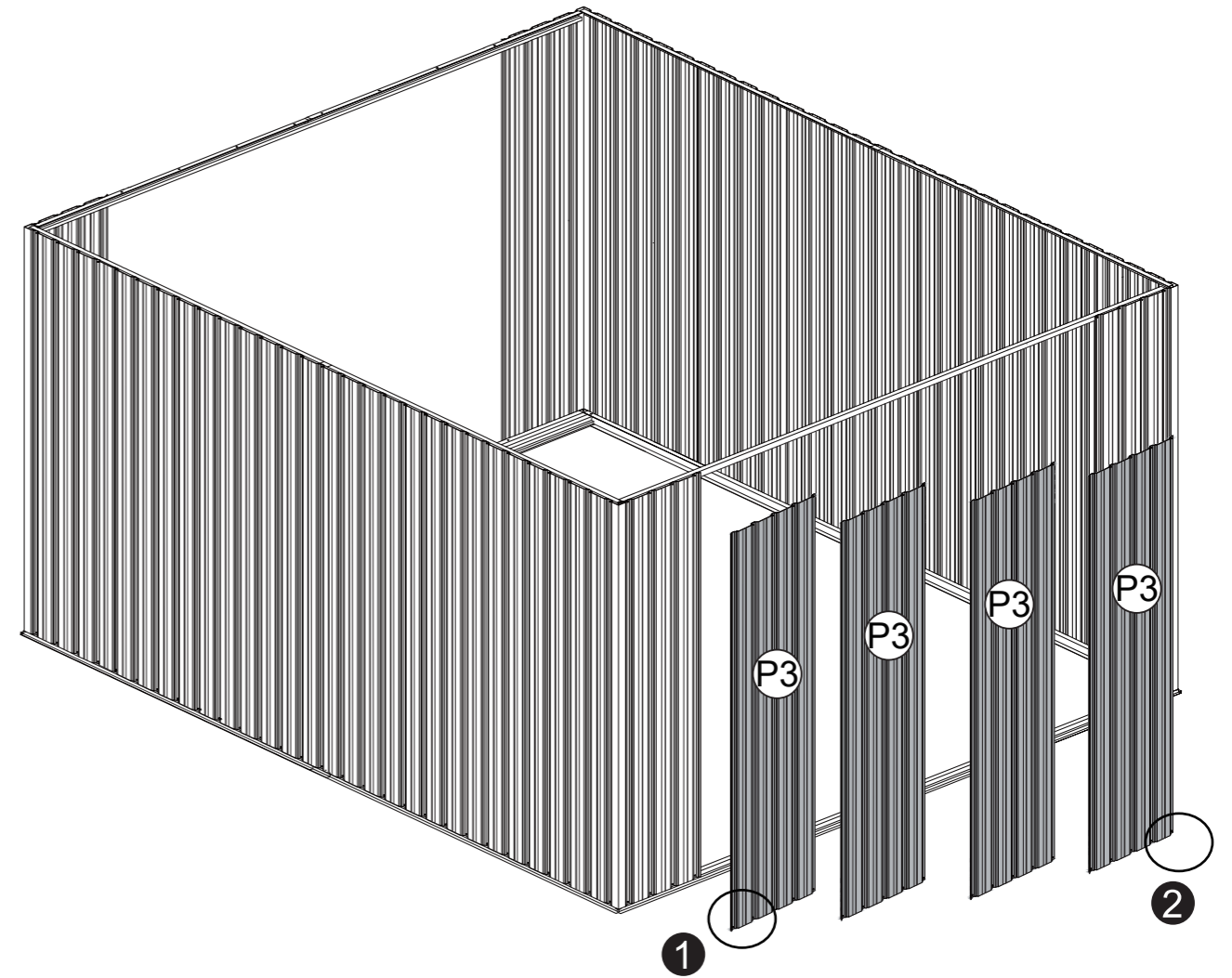

STEP 13/ Paso 13

P3		X1	F1		X5
S1		X5			

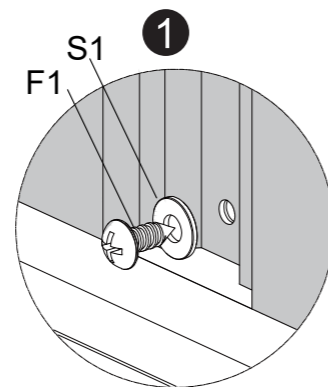
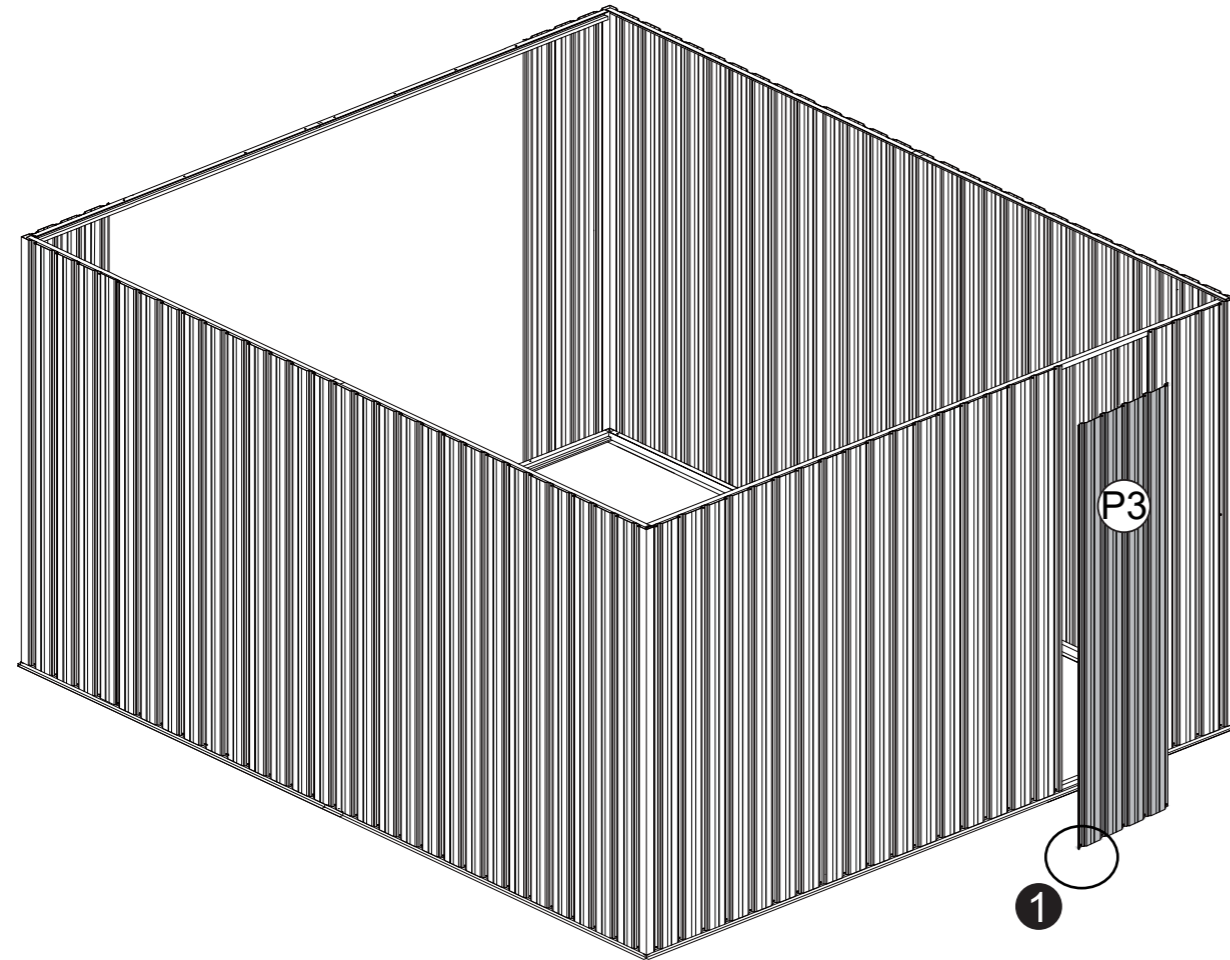



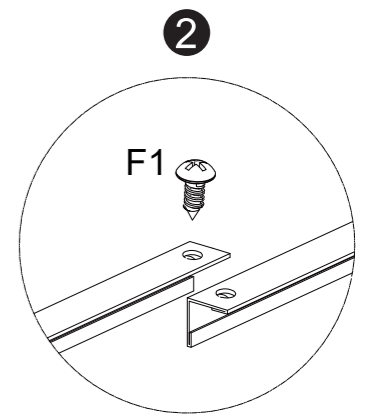
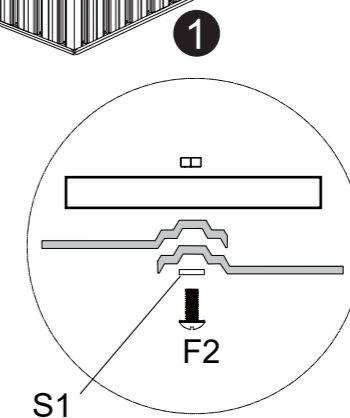
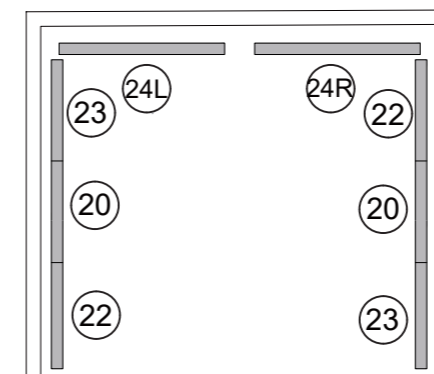
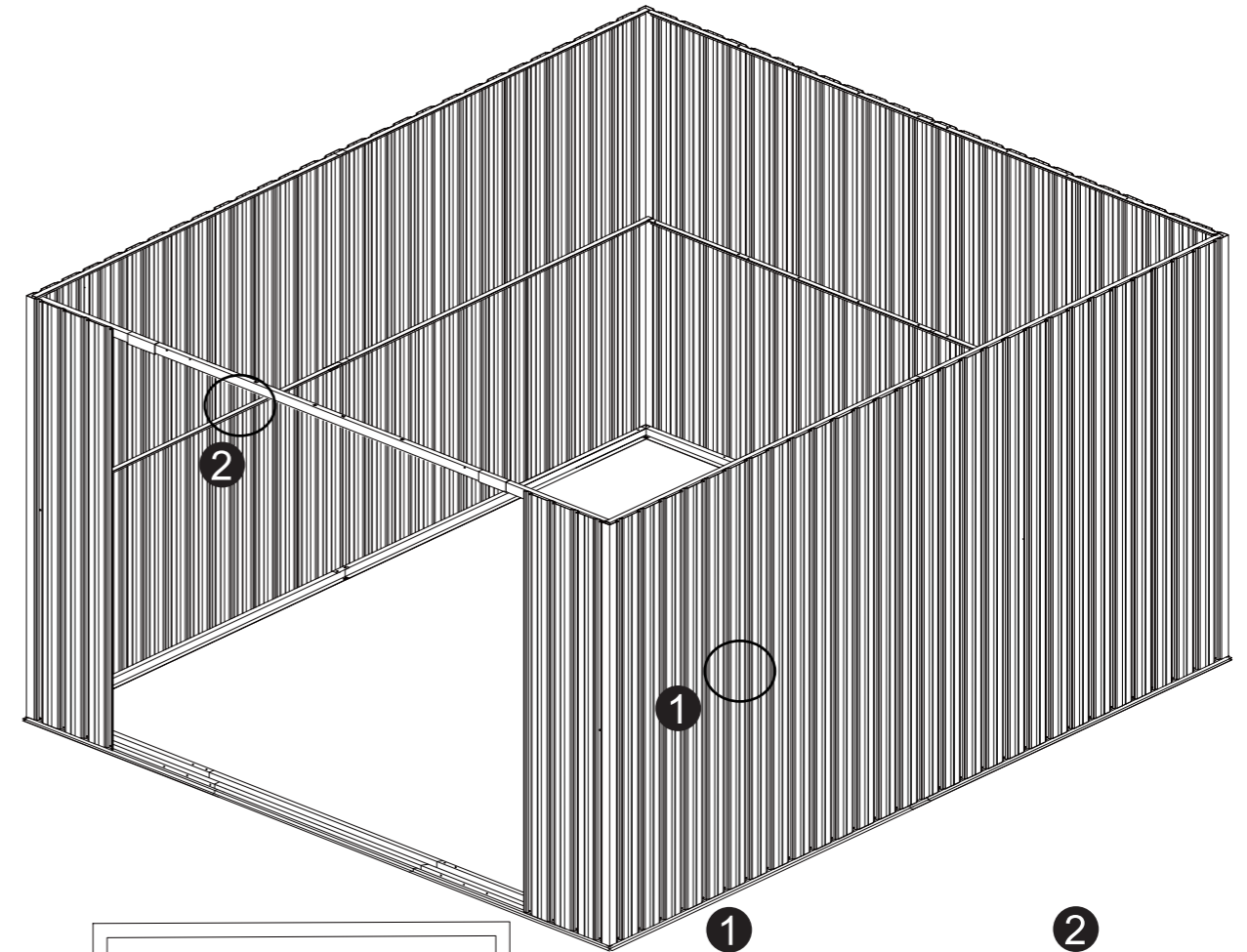

STEP 14/ Paso 14

20		X2	22		X2
23		X2	24L		X1
24R		X1	F1		X5
F2		X23	S1		X23

First, use F2 to secure the waist rail and wall panel, then use F1 to assemble parts 20, 22, 23, 24L, and 24R.
 £ Primero, utilice F2 para asegurar el riel de la cintura y el panel de la pared, luego use F1 para ensamblar las partes 20, 22, 23, 24L y 24R.£





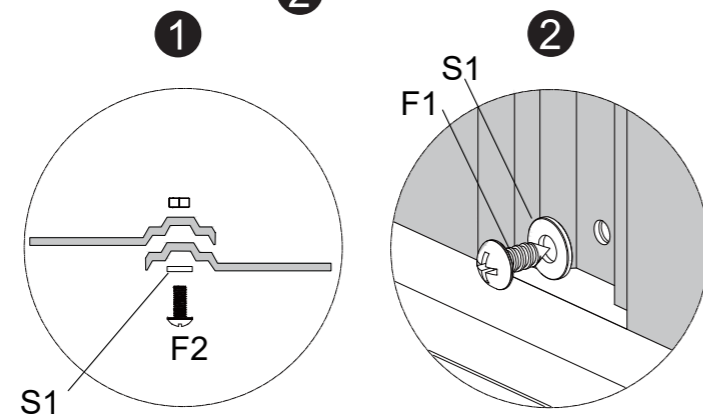
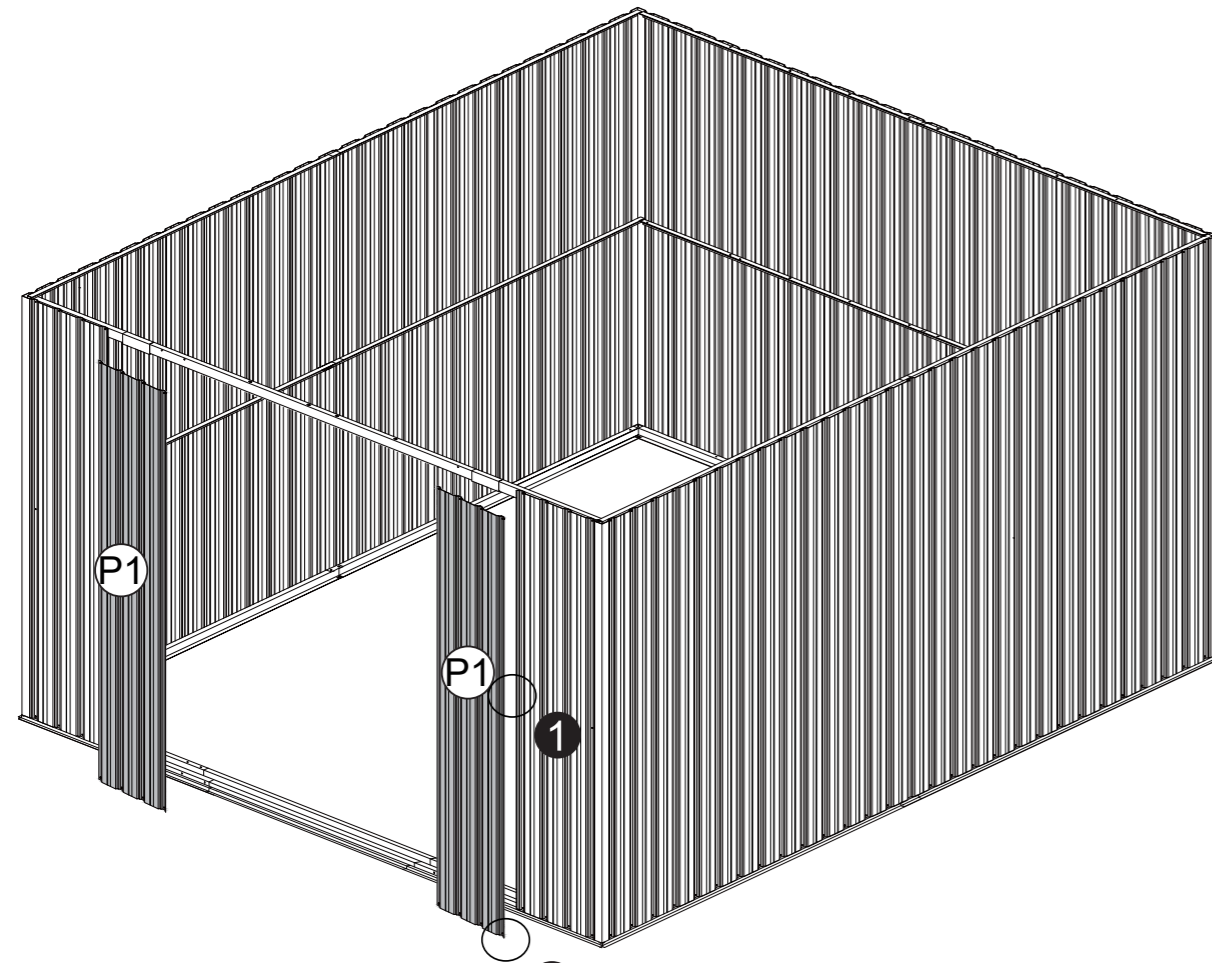

STEP 15/ Paso 15

P1		X2	F1		X12
F2		X2	S1		X14

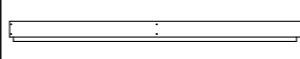
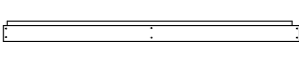

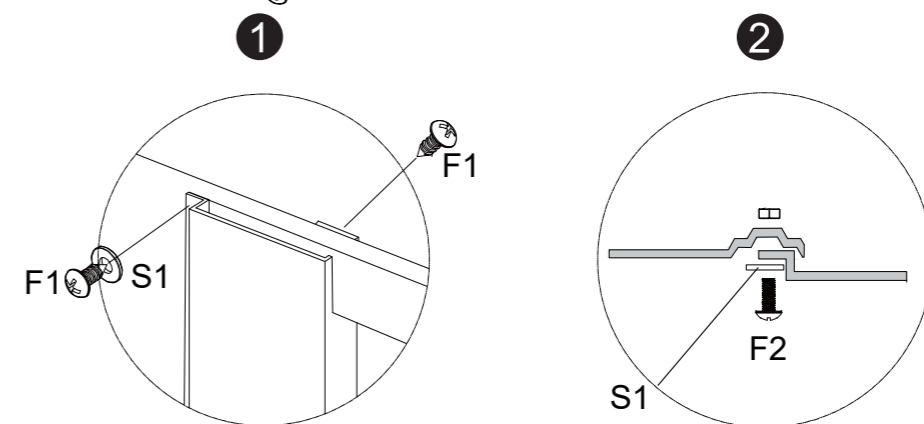
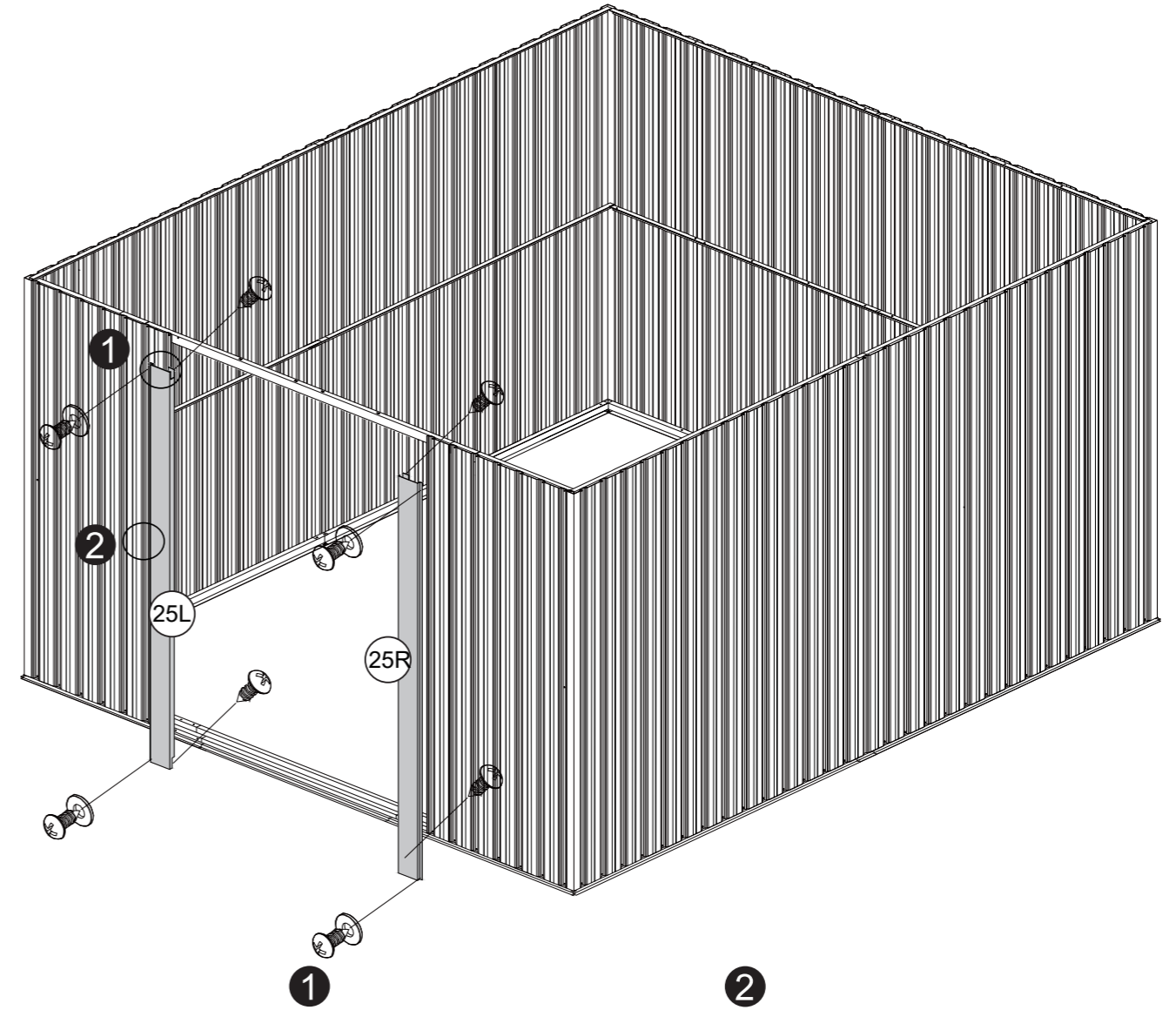

STEP 16/ Paso 16

25L		X1	25R		X1
F1		X8	F2		X2
S1		X10			



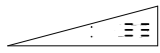
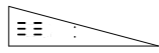
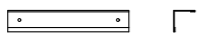

STEP 17/ Paso 17

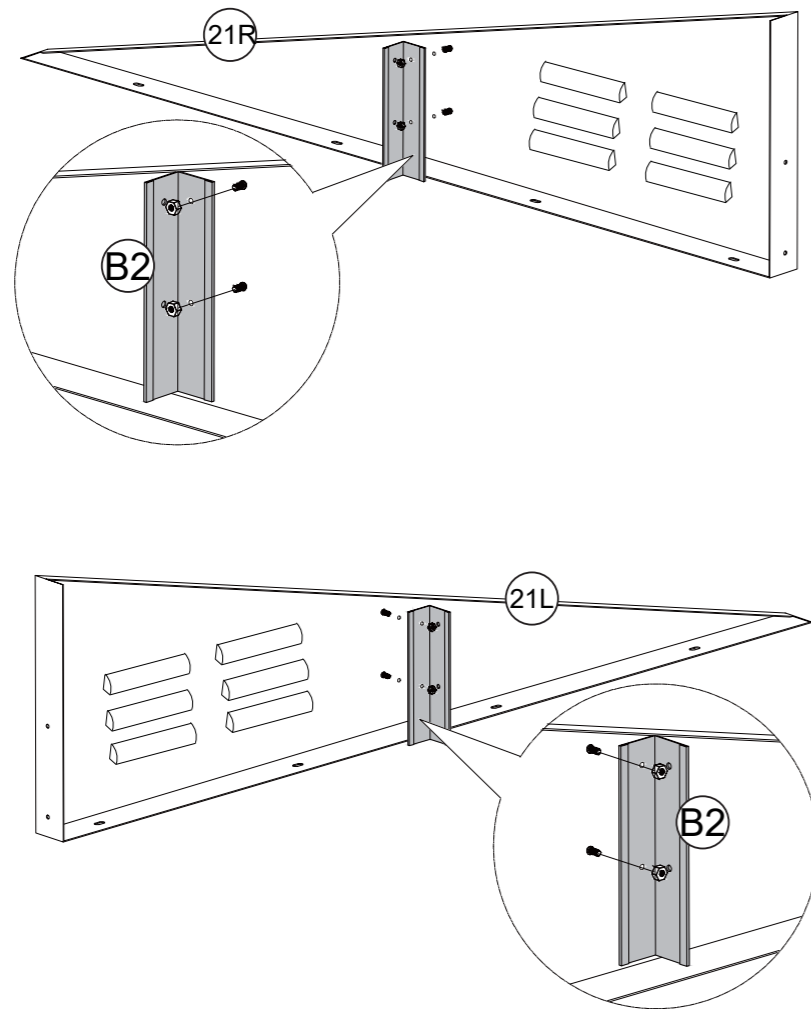
21L		X2	21R		X2
B2		X4	F2		X8

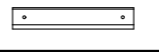

x2

STEP 18/ Paso 18

B1		X4	F2		X4
----	---	----	----	---	----

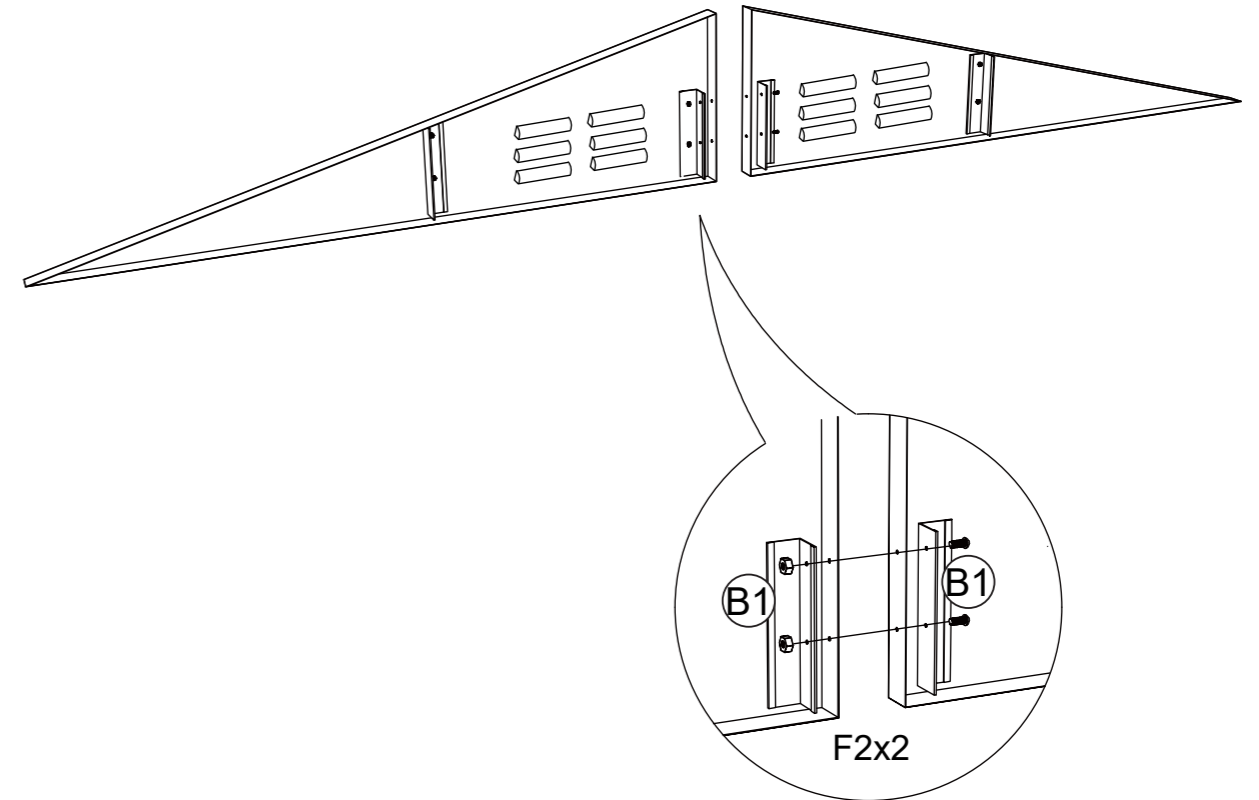

x2

STEP 19/ Paso 19

F1		X10
----	---	-----

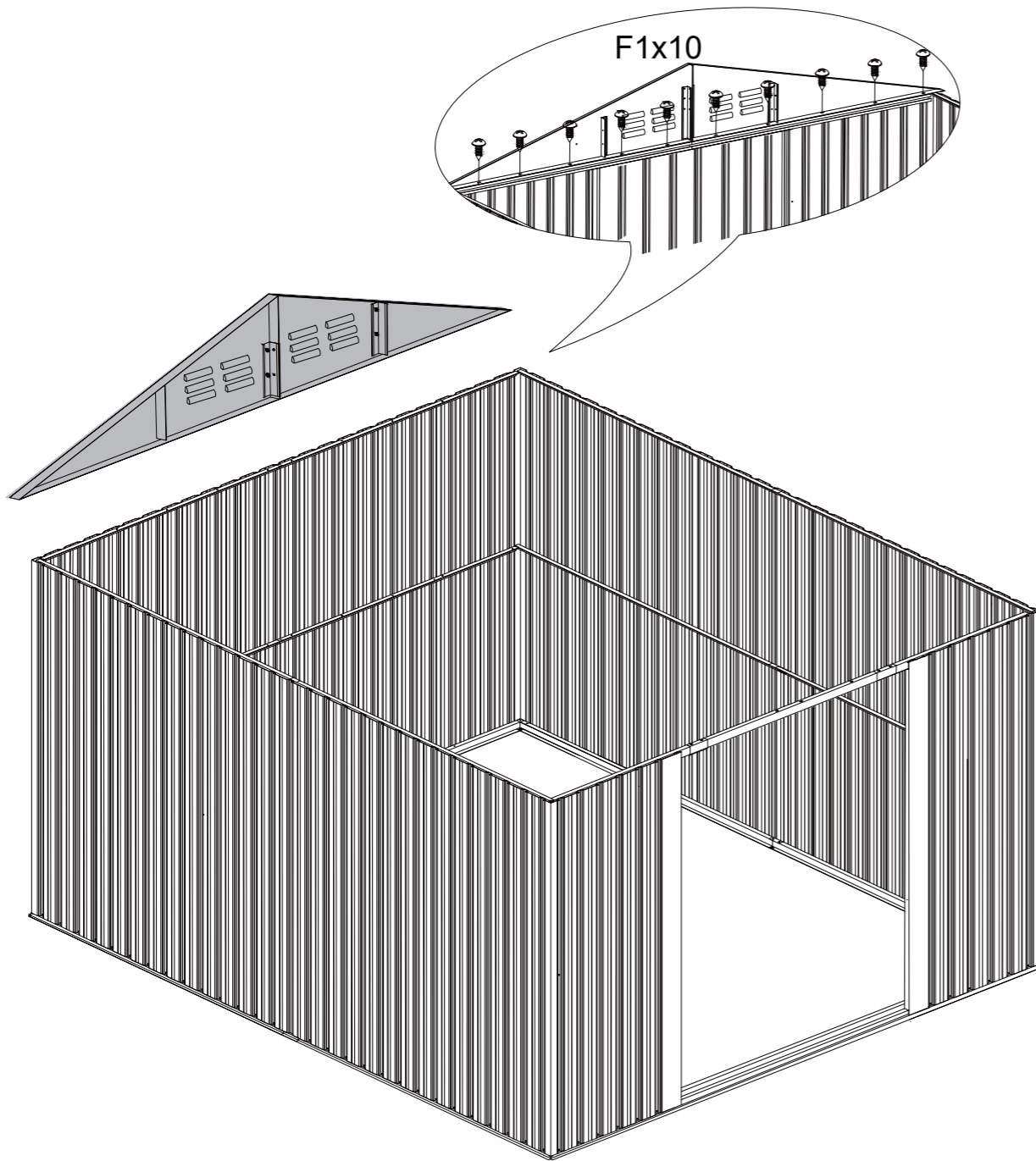



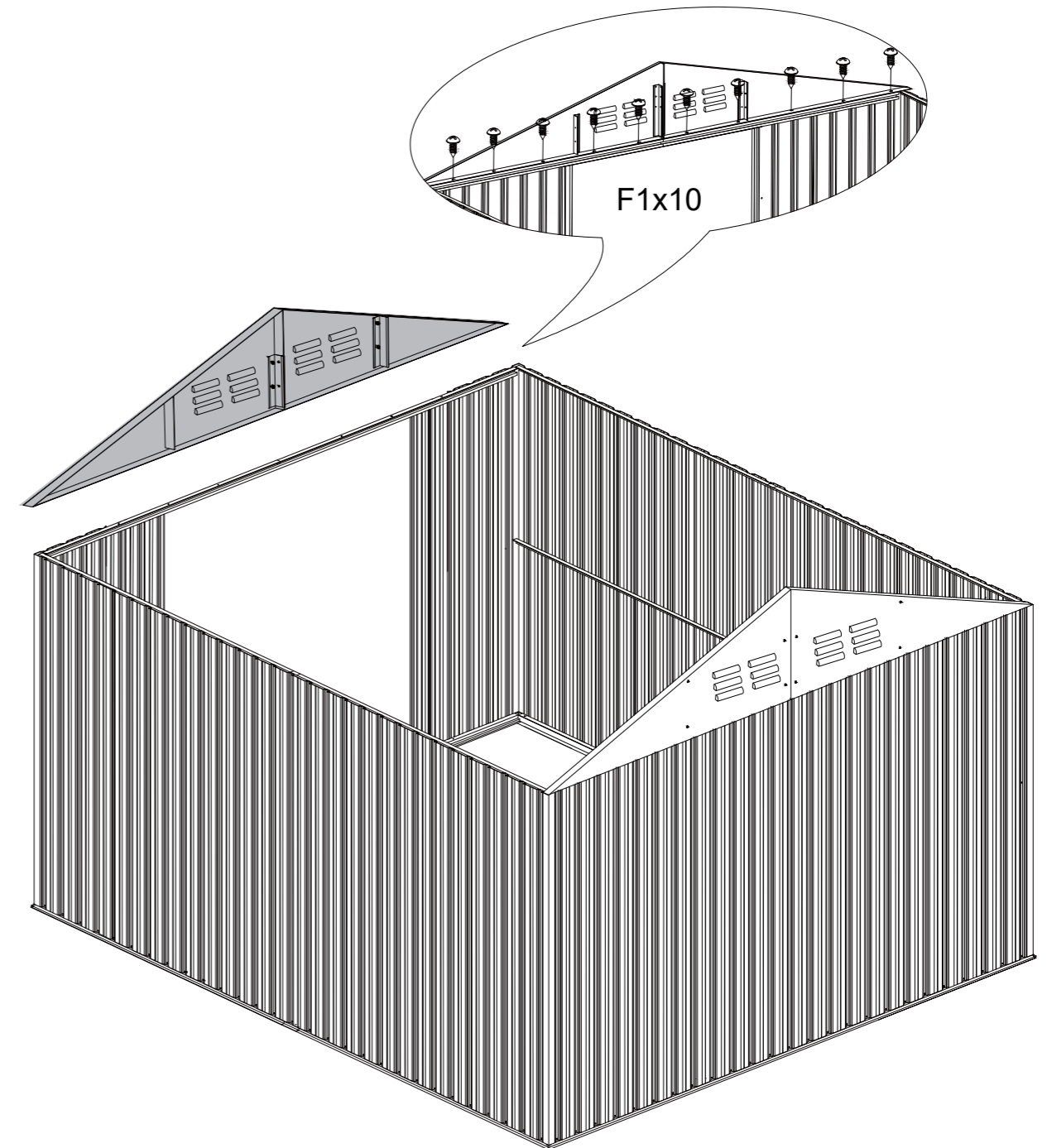

STEP 20/ Paso 20

F1		X10
----	---	-----





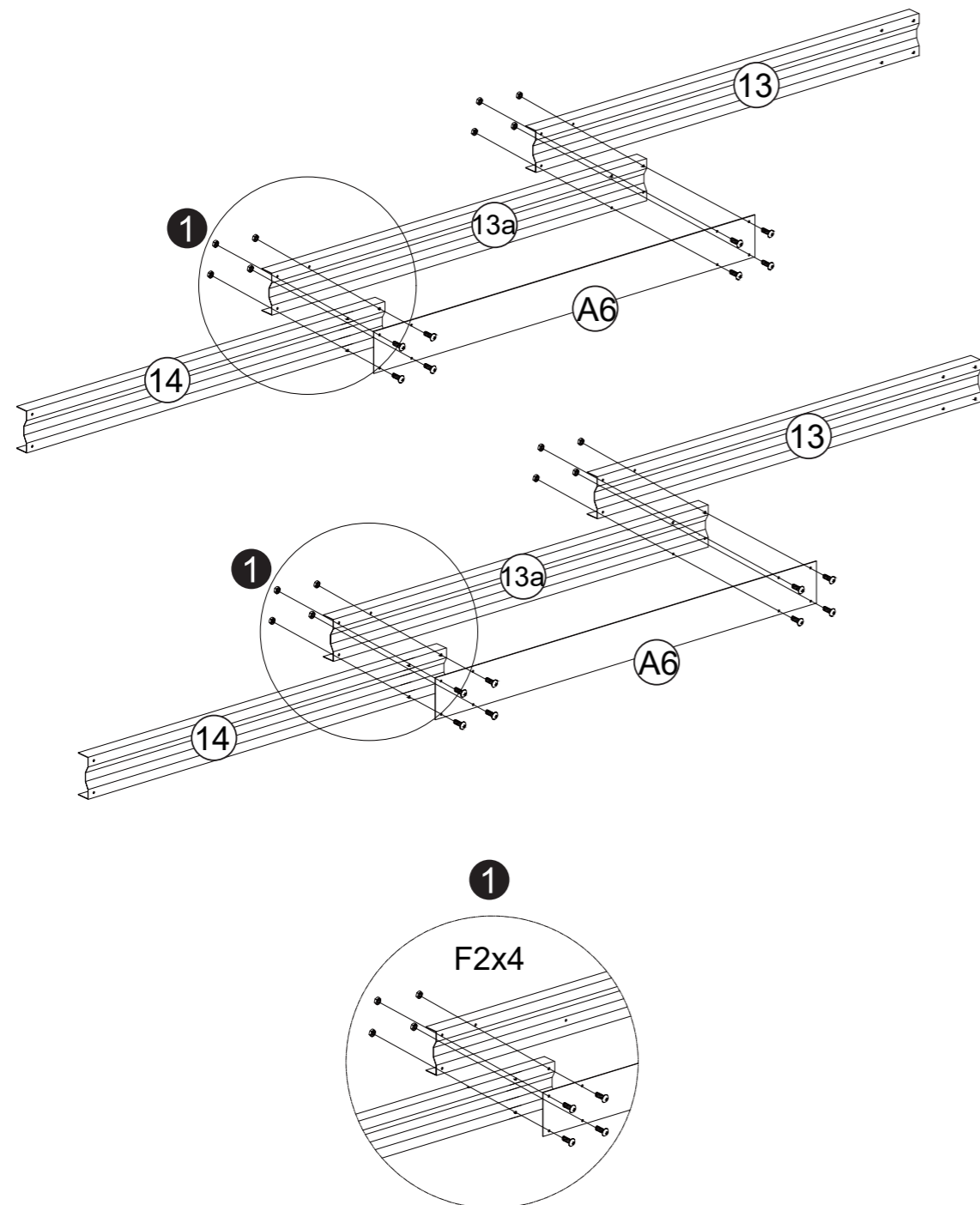

STEP 21/ Paso 21

13		X2	13a		X2
14		X2	A6		X2
F2		X16			

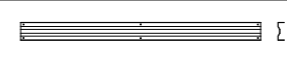

STEP 22/ Paso 22

13		X2	13a		X2
14		X2	A6		X1
F2		X8			

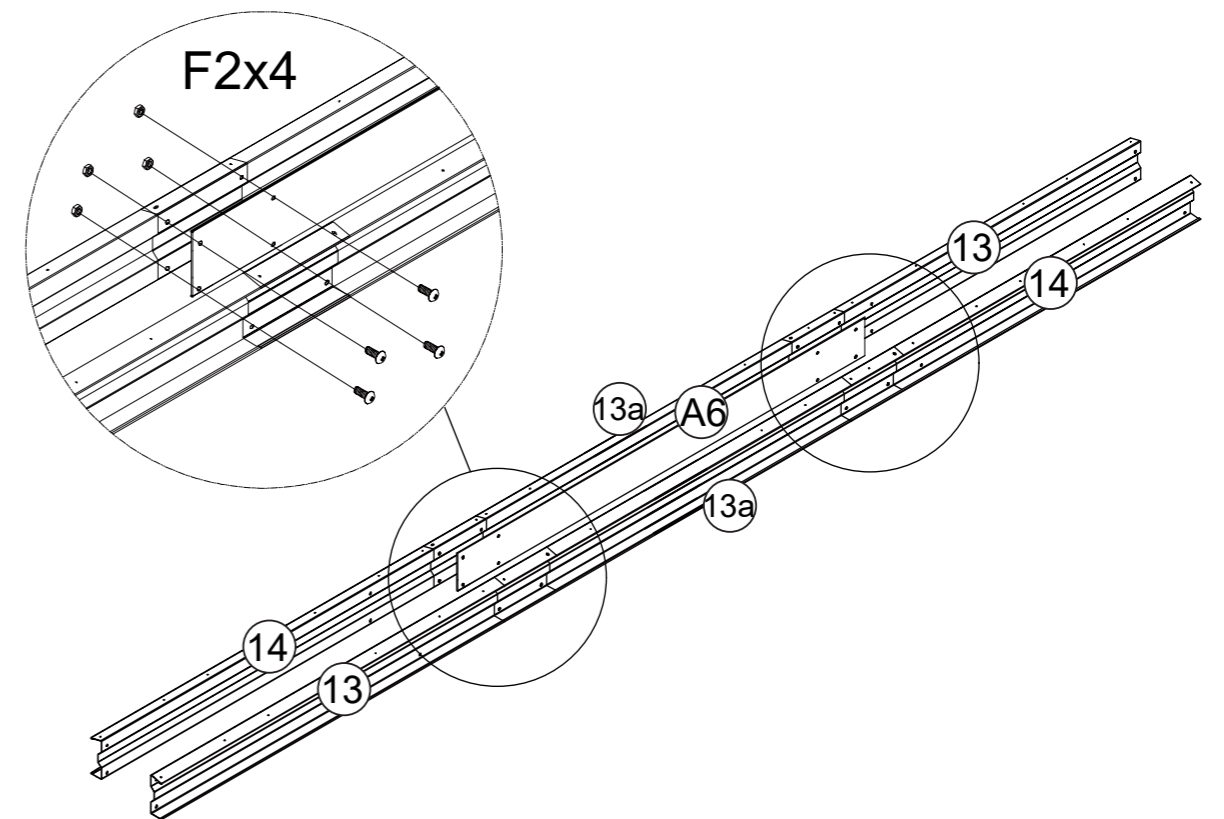

STEP 23/ Paso 23

F2		X4
----	---	----

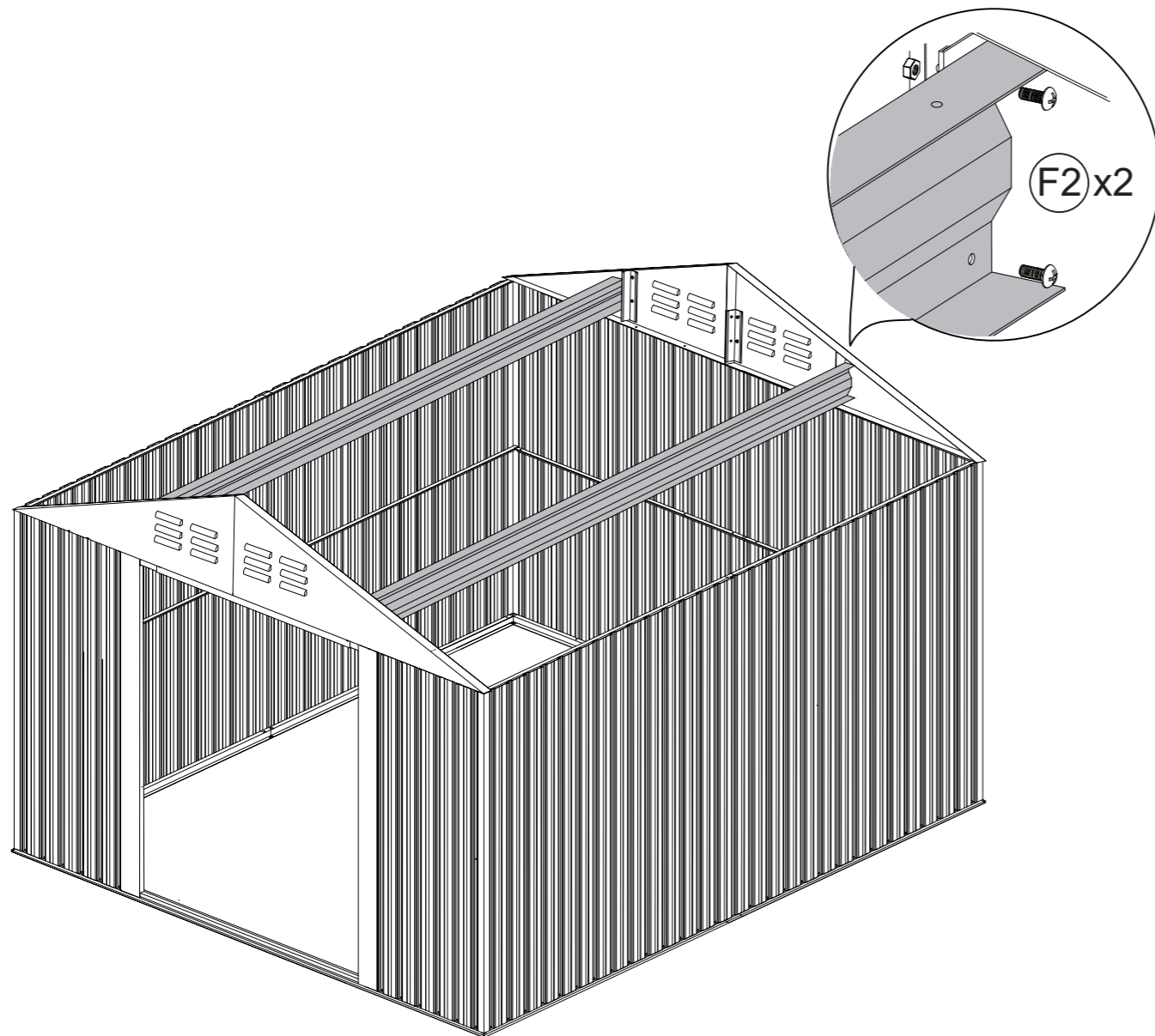

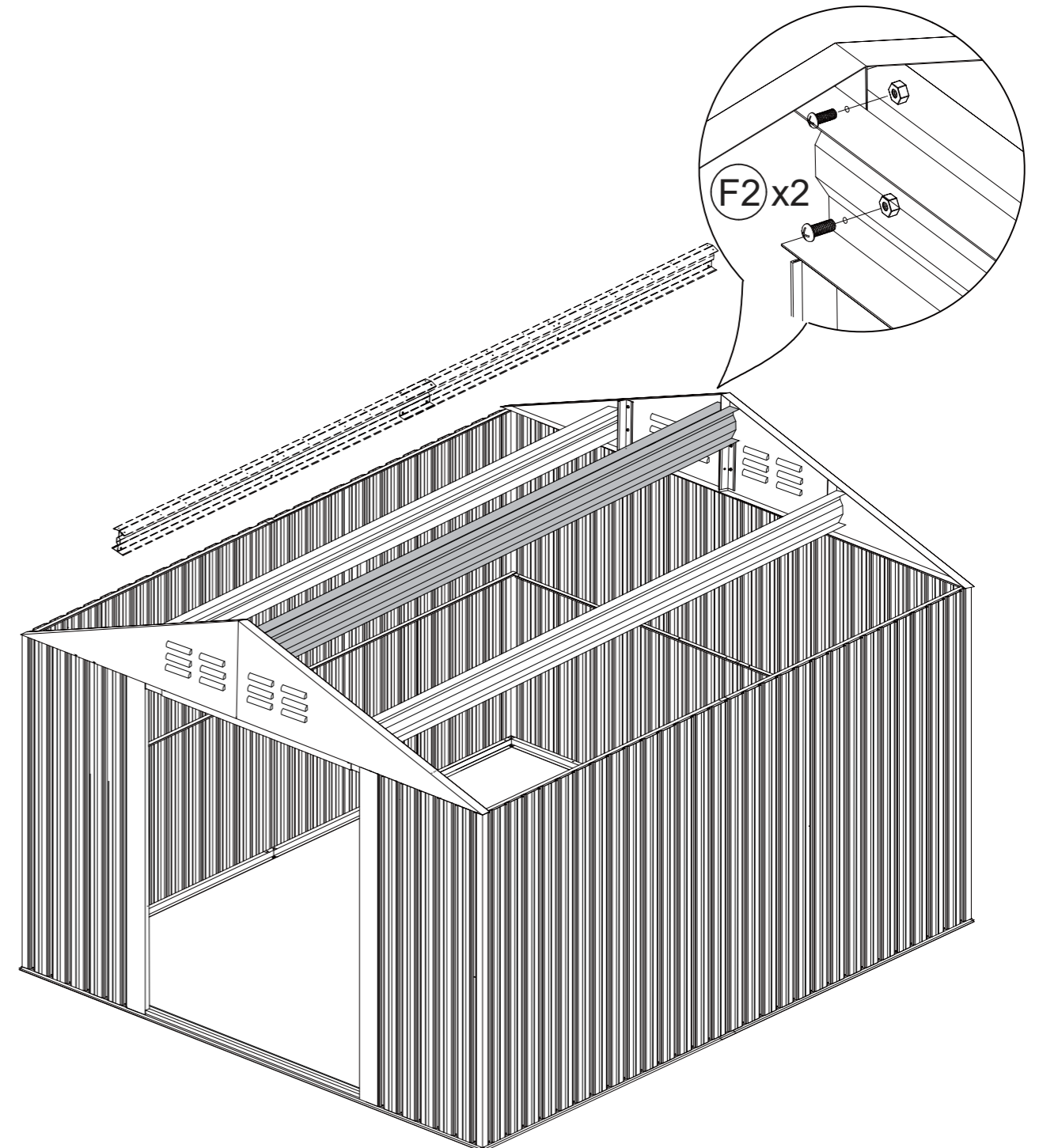

STEP 24/ Paso 24

F2		X4
----	---	----



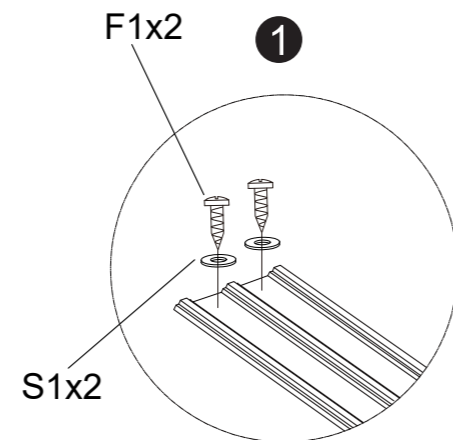
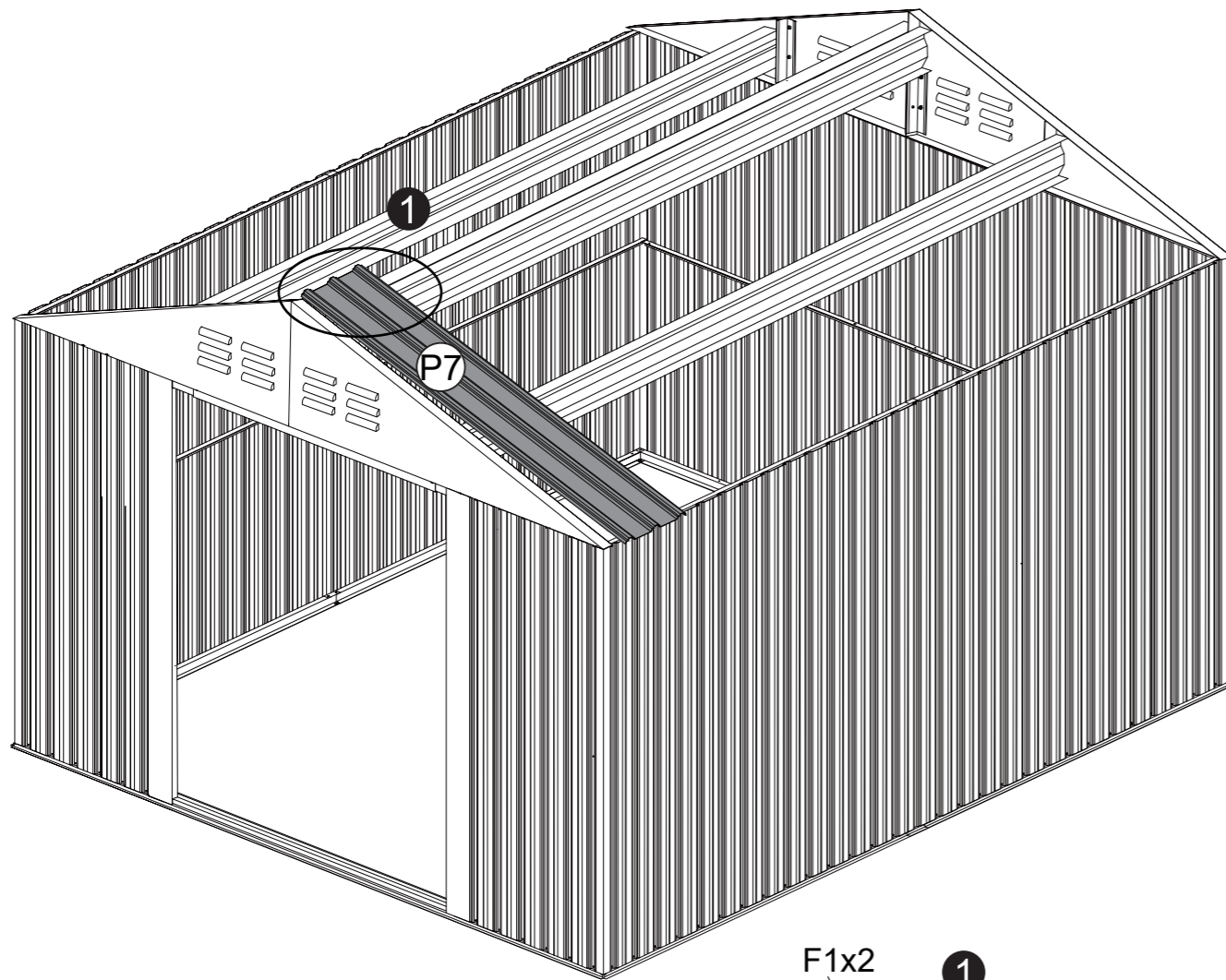

STEP 25/ Paso 25

P7		X1	F1		X6
S1		X6			



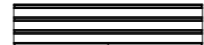

STEP 26/ Paso 26

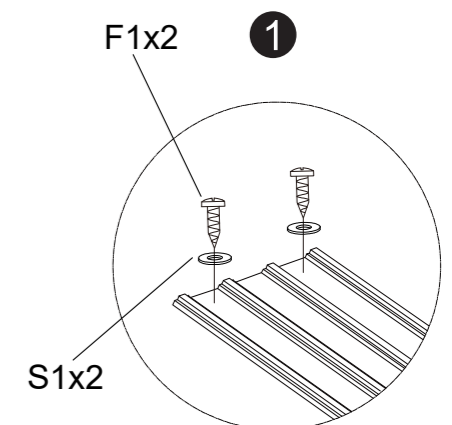
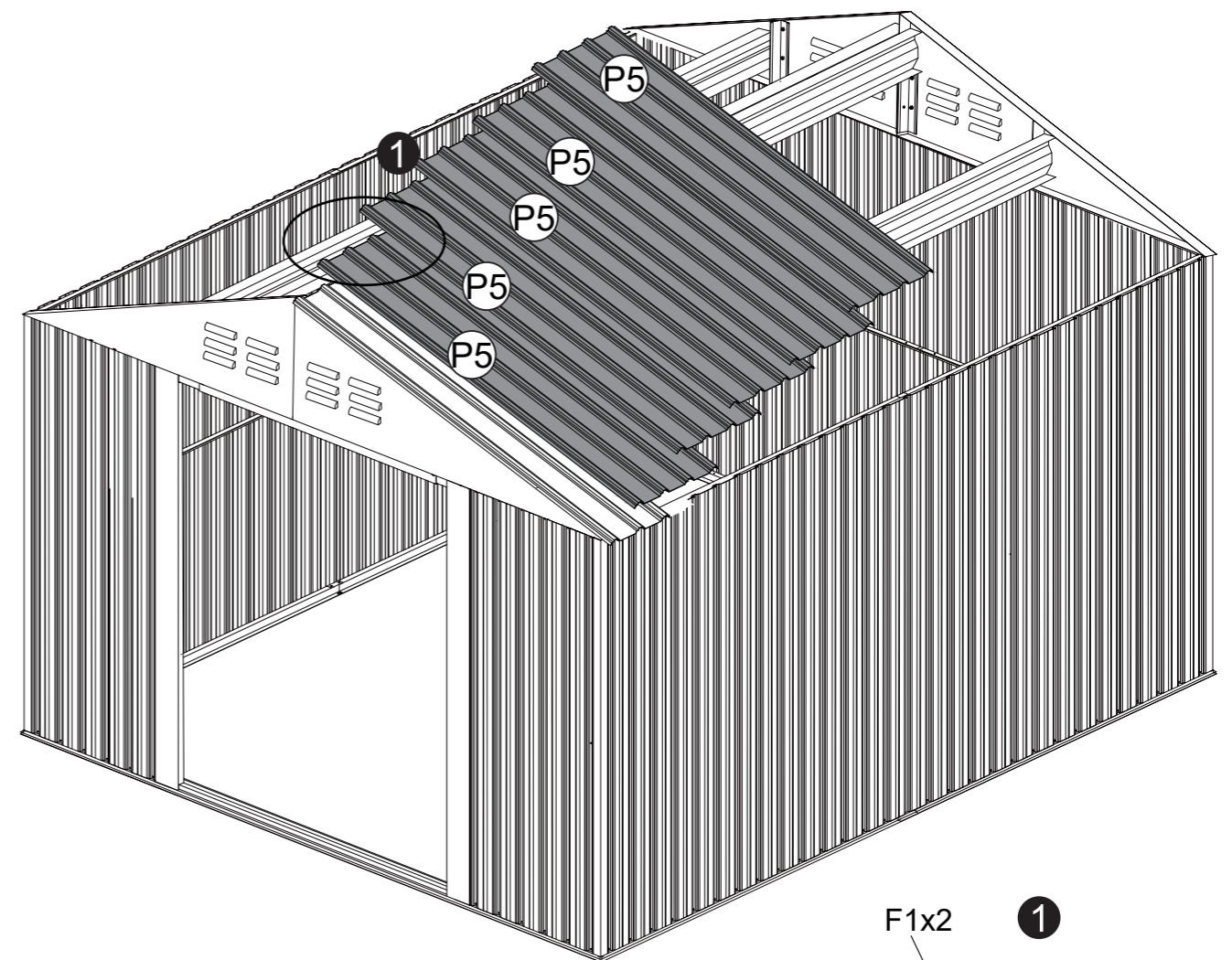
P5		X5	F1		X30
S1		X30			



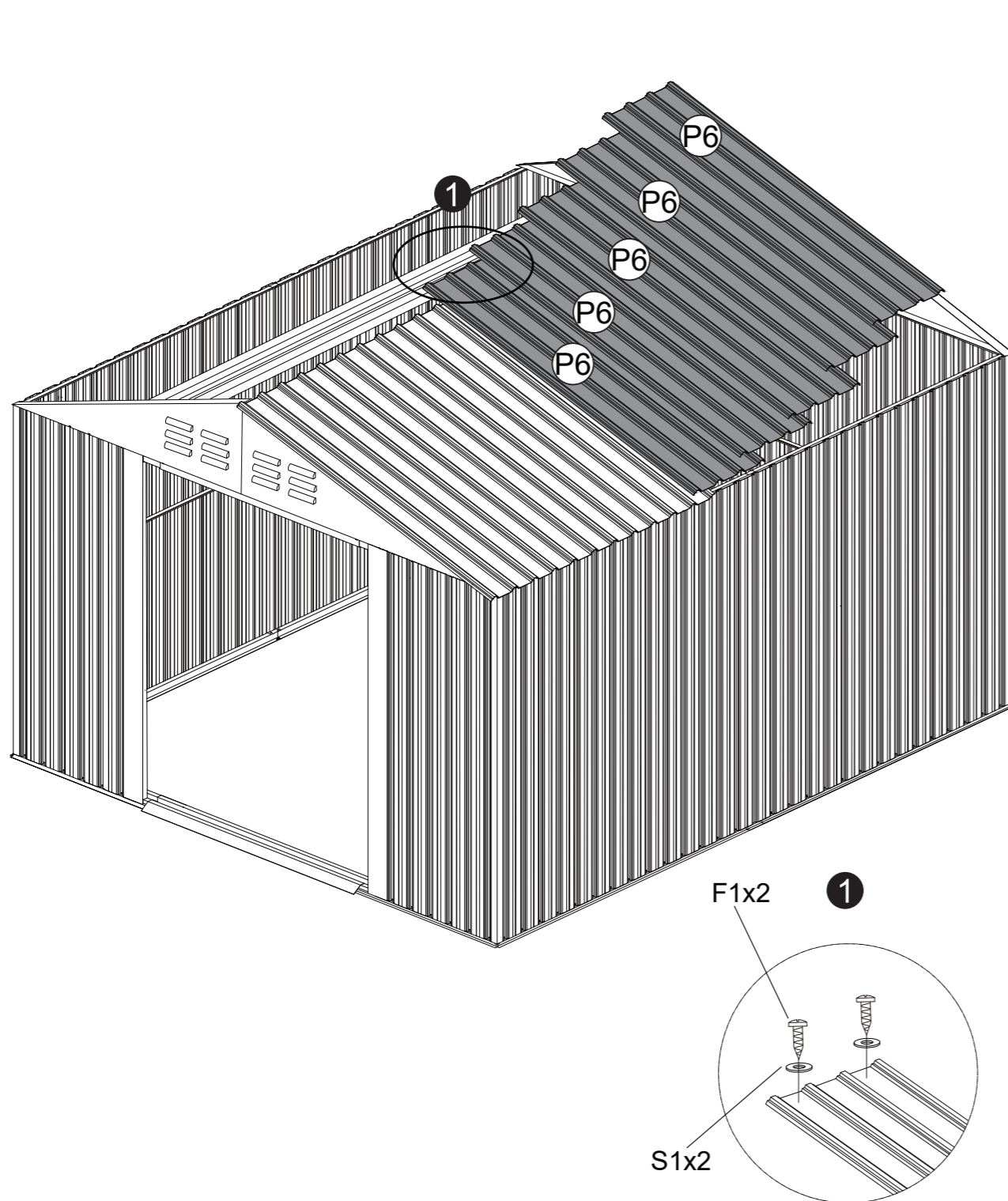

STEP 27/ Paso 27

P6		X5	F1		X30
S1		X30			



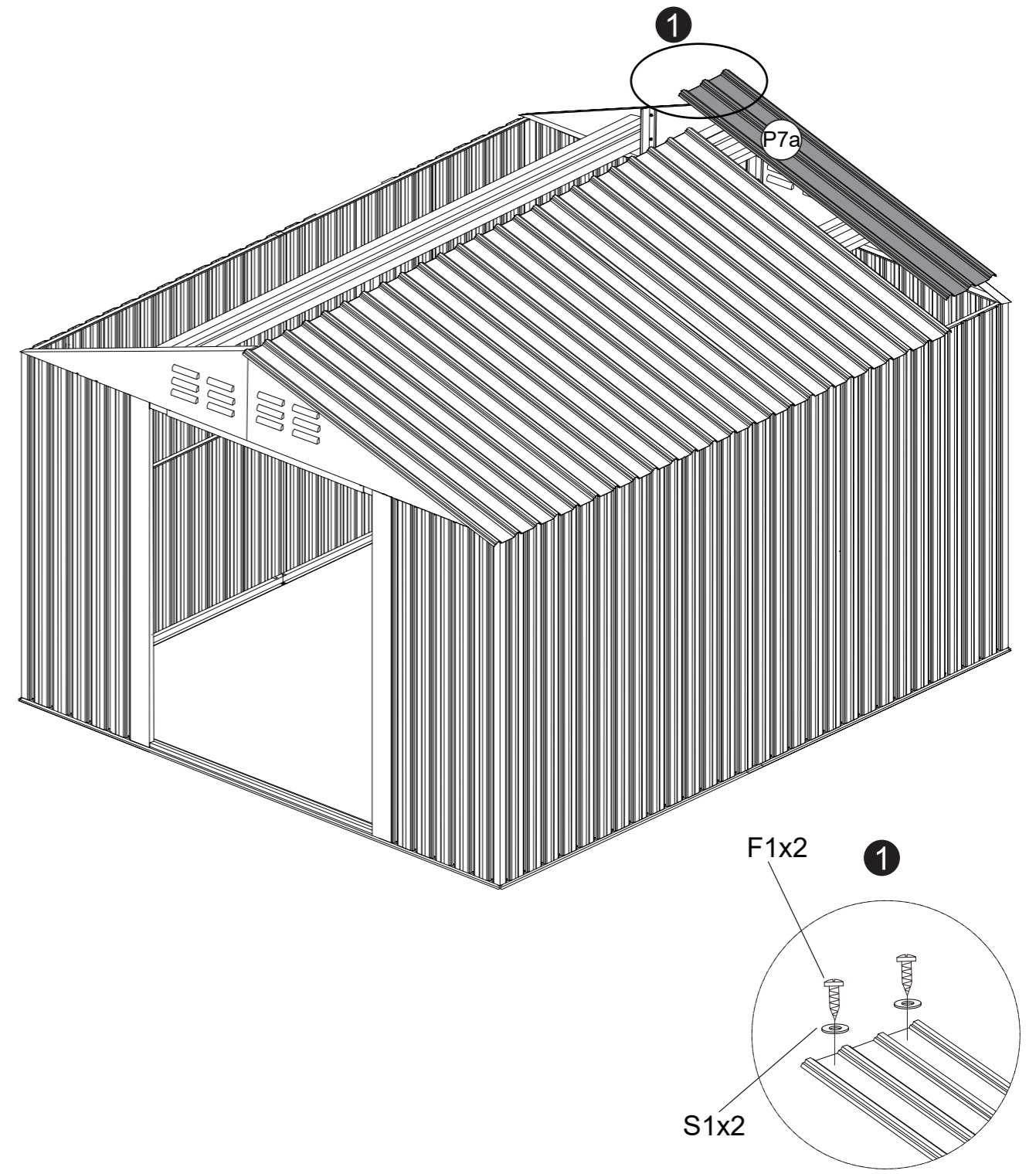

STEP 28/ Paso 28

P7a		X1	F1		X6
S1		X6			



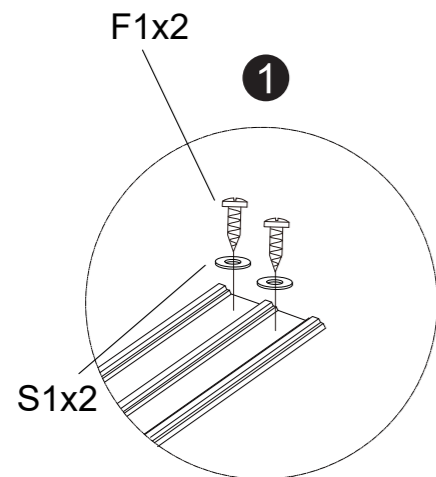
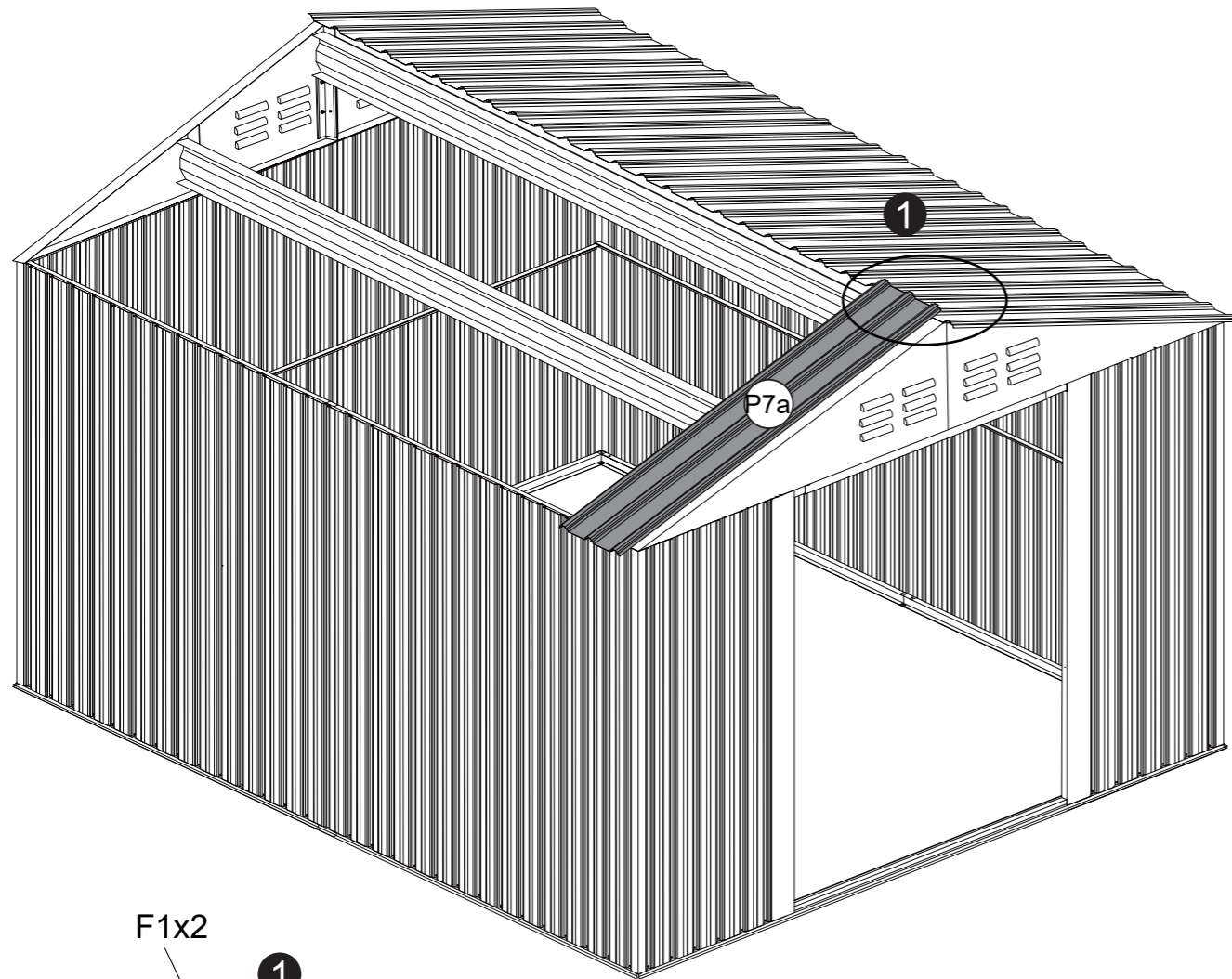

STEP 29/ Paso 29

P7a		X1	F1		X6
S1		X6			



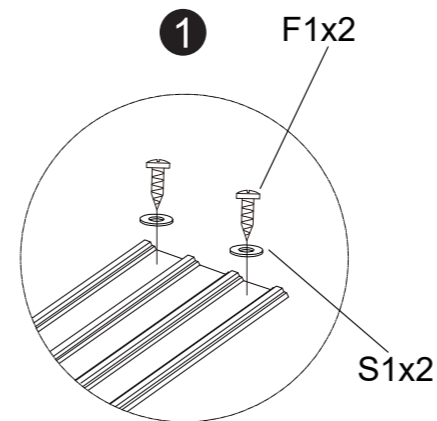
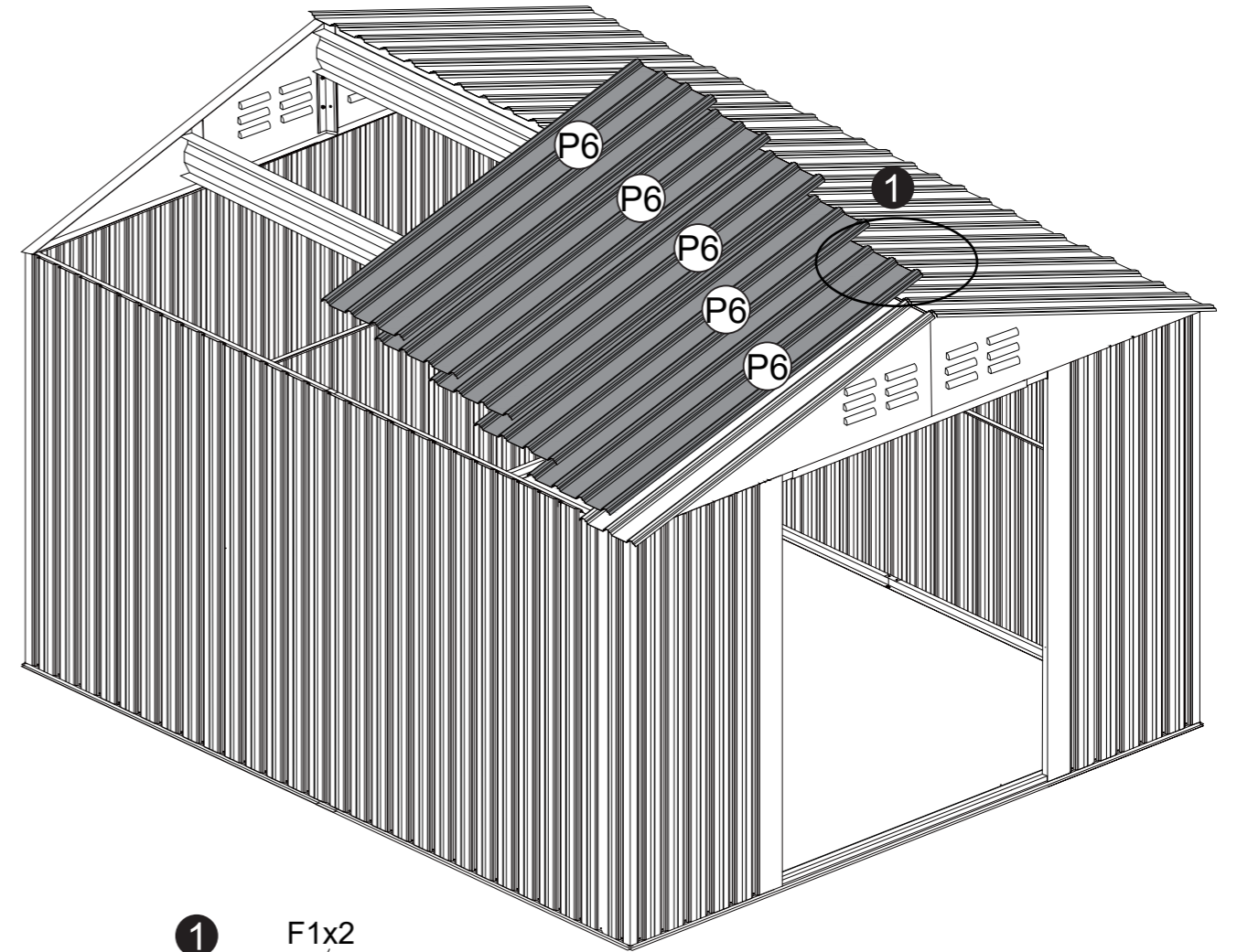

STEP 30/ Paso 30

P6		X5	F1		X30
S1		X30			



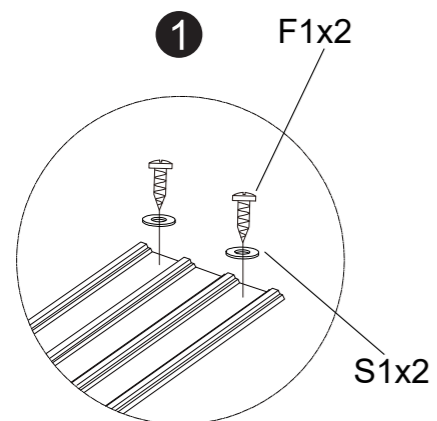
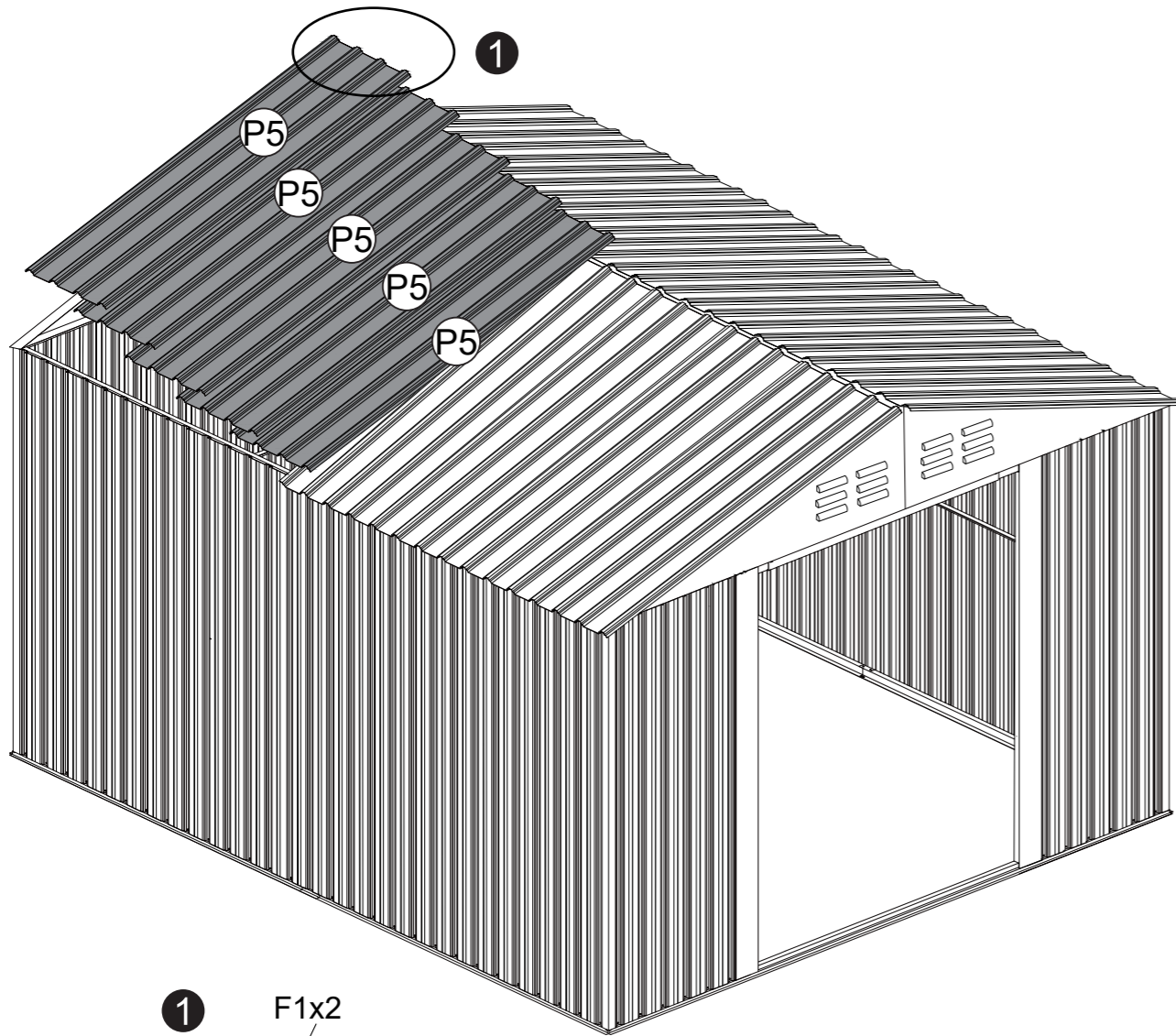

STEP 31/ Paso 31

P5		X5	F1		X30
S1		X30			





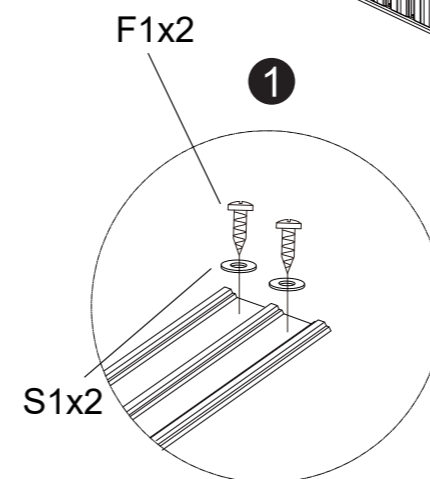
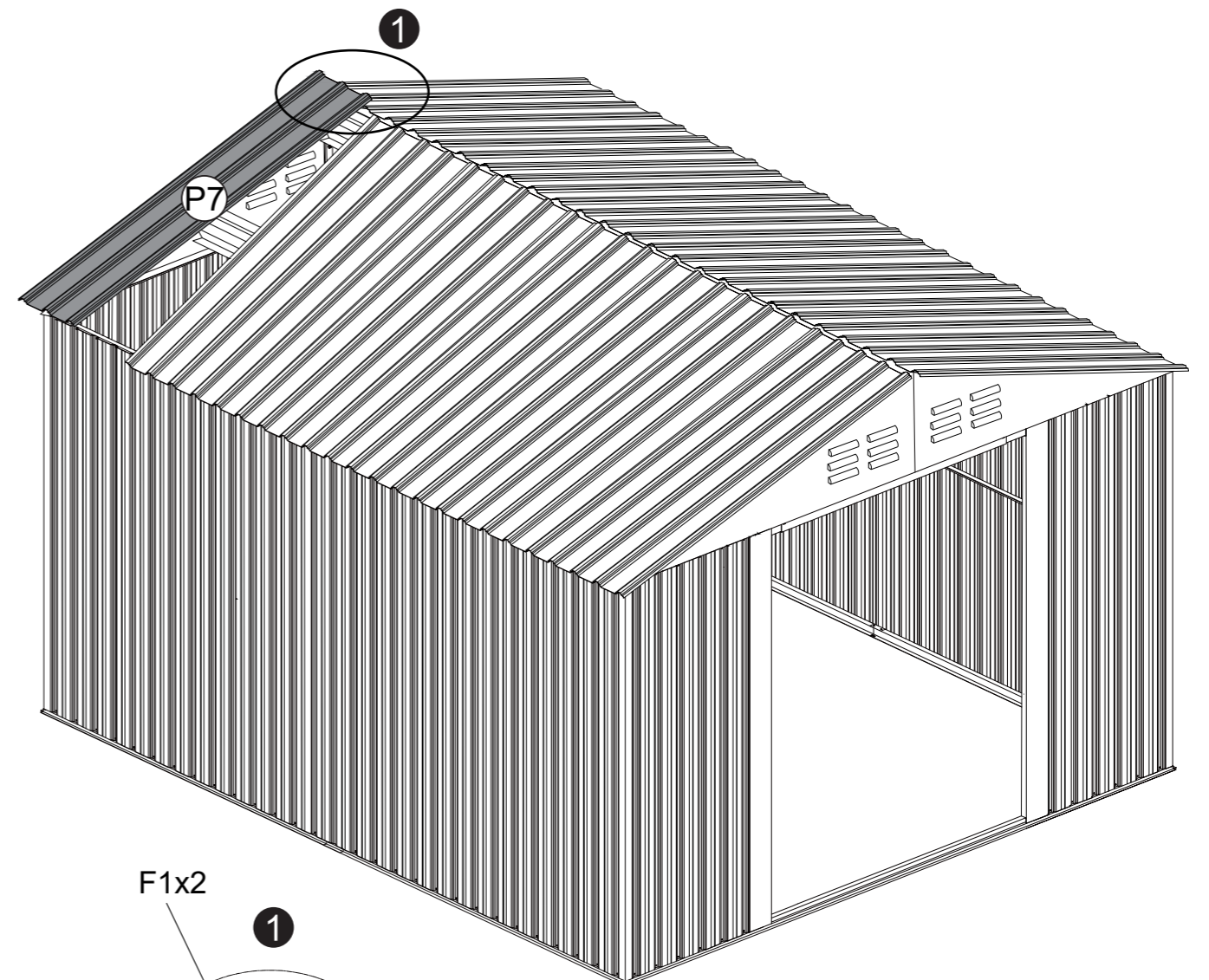

STEP 32/ Paso 32

P7		X1	F1		X6
S1		X6			





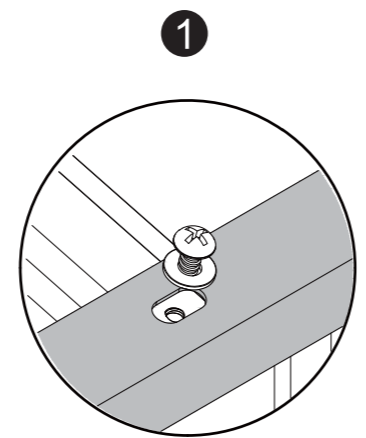
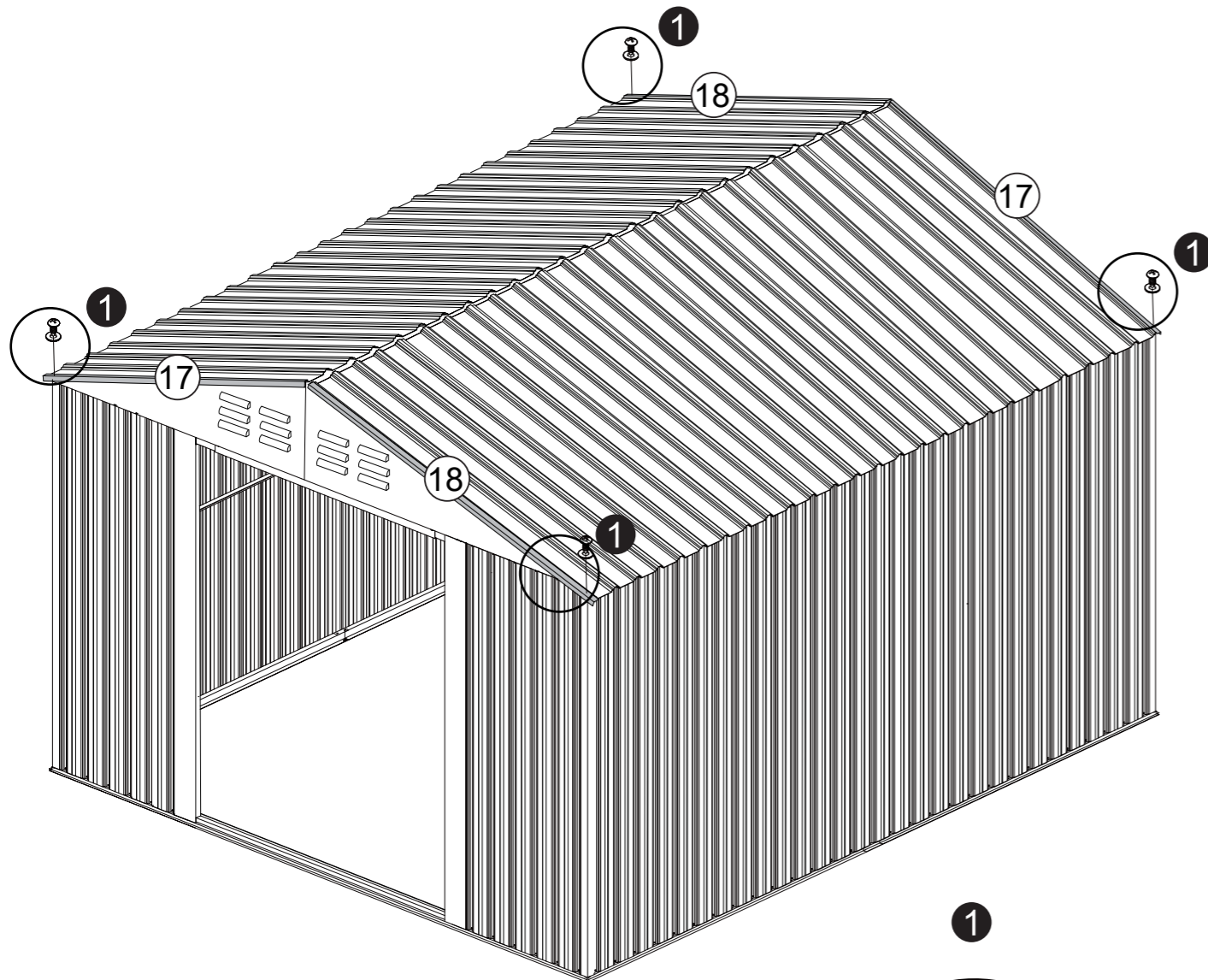

STEP 33/ Paso 33

17		X2	18		X2
F1		X4	S1		X4





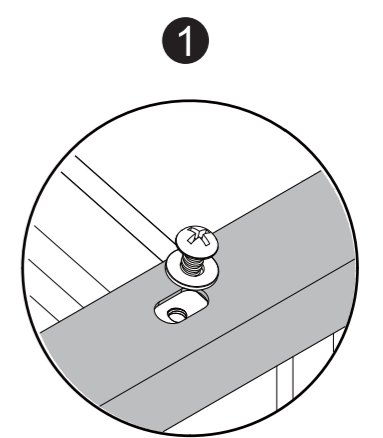
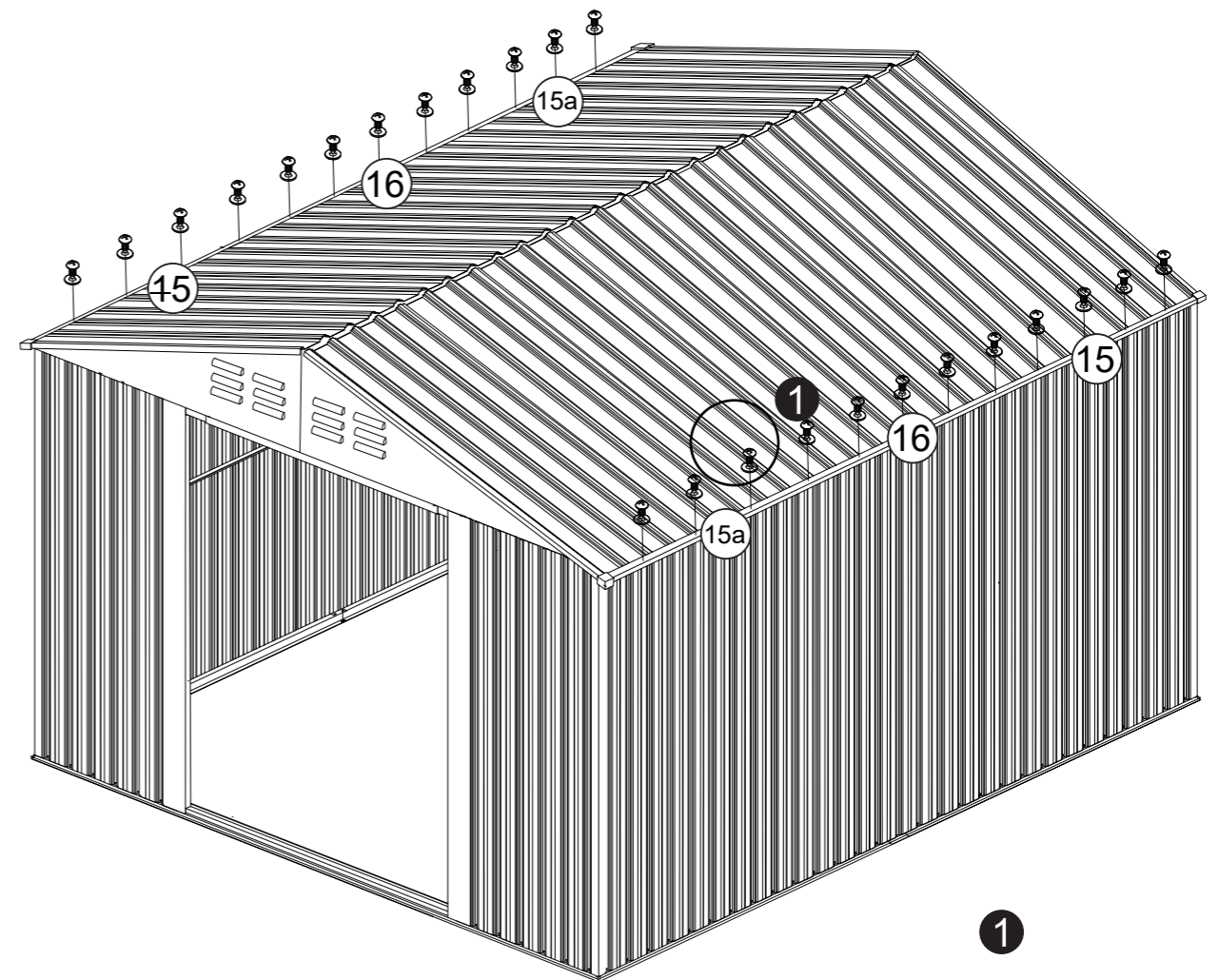

STEP 34/ Paso 34

15		X2	15a		X2
16		X2	F1		X24
S1		X24			





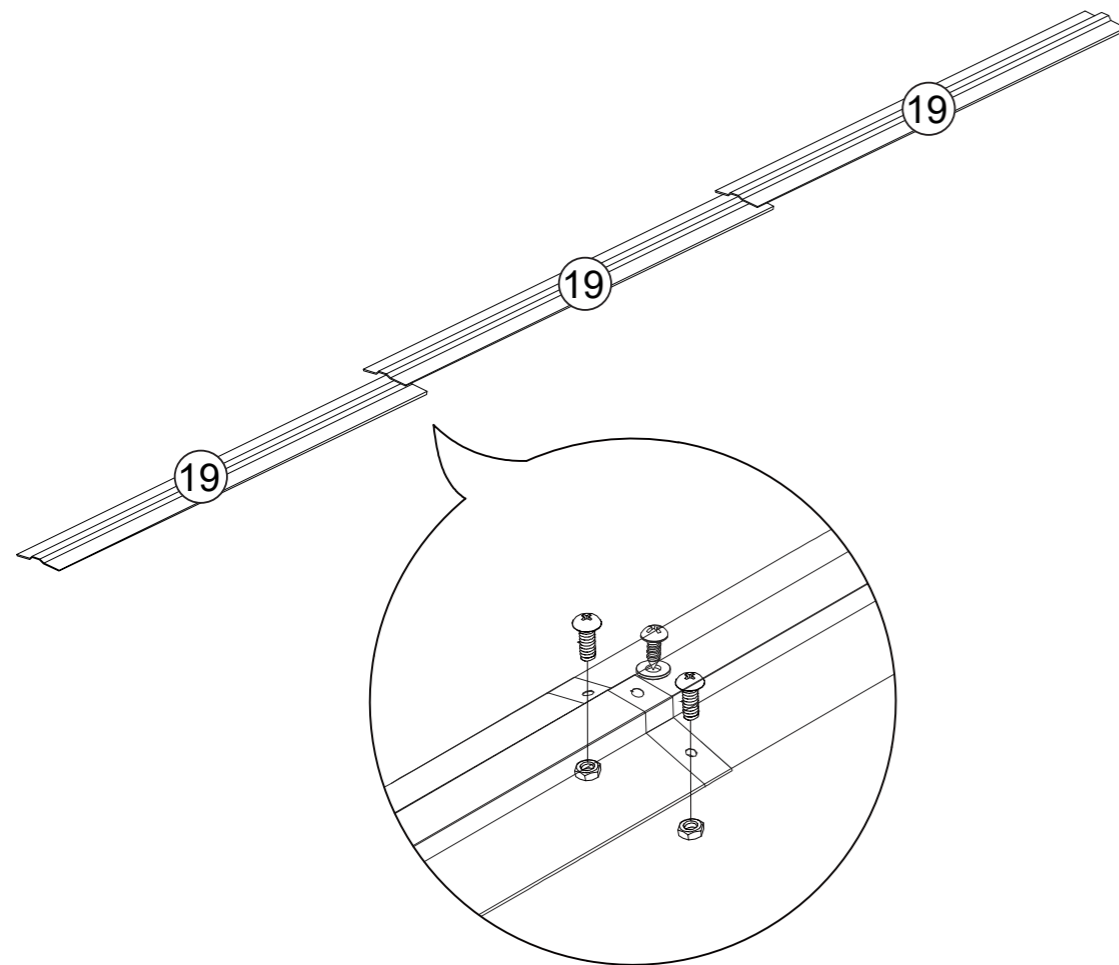

STEP 35/ Paso 35

19		X3	F1		X2
F2		X4	S1		X2



STEP 36/ Paso 36

GC		X4	GE		X2
F1		X10	S1		X6

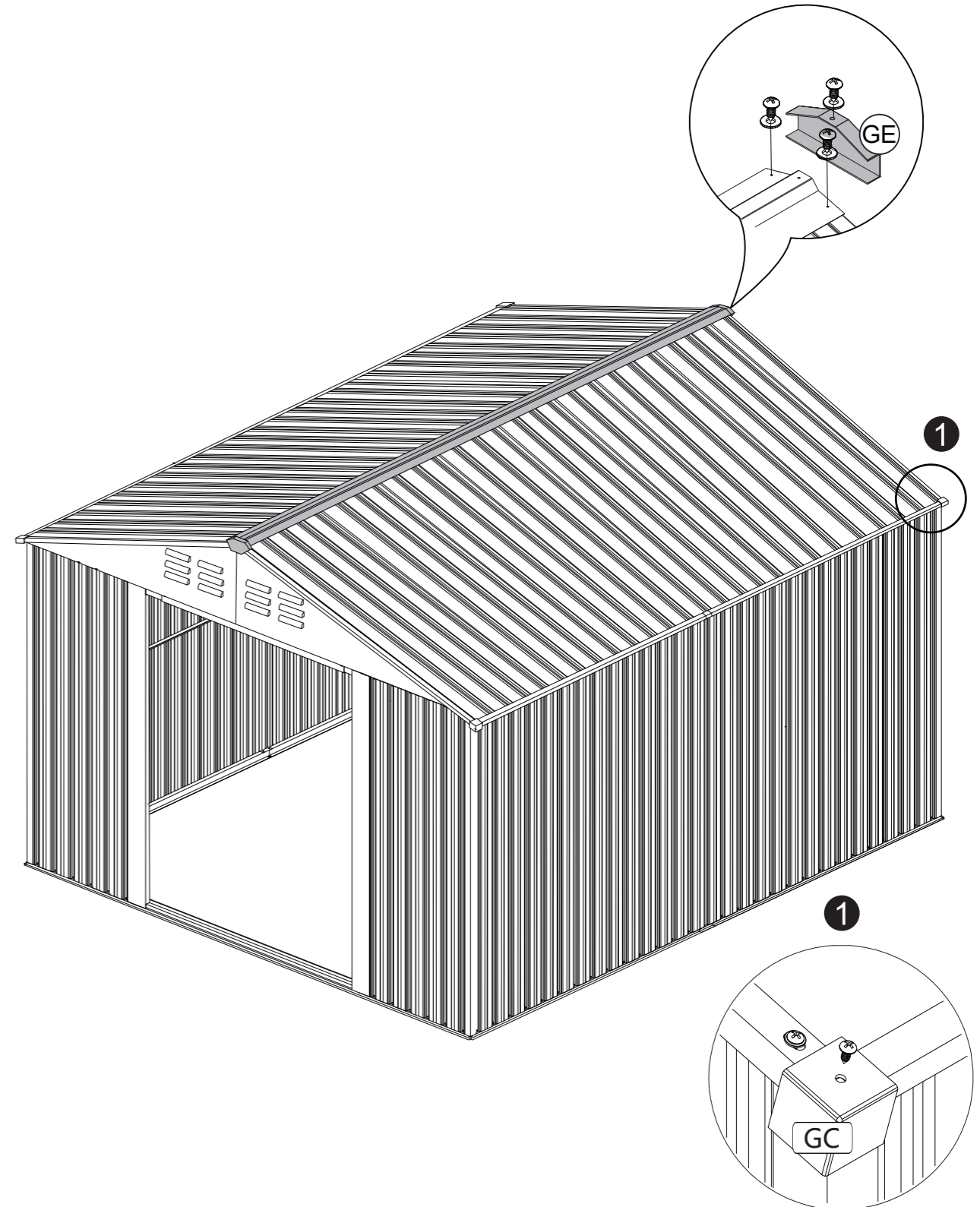

STEP 37/ Paso 37

27		X2	D1		X1
D1a		X1	D1b		X1
D1c		X1	D1d		X1
Ca3		X1	F1		X12
F2		X6	S1		X8

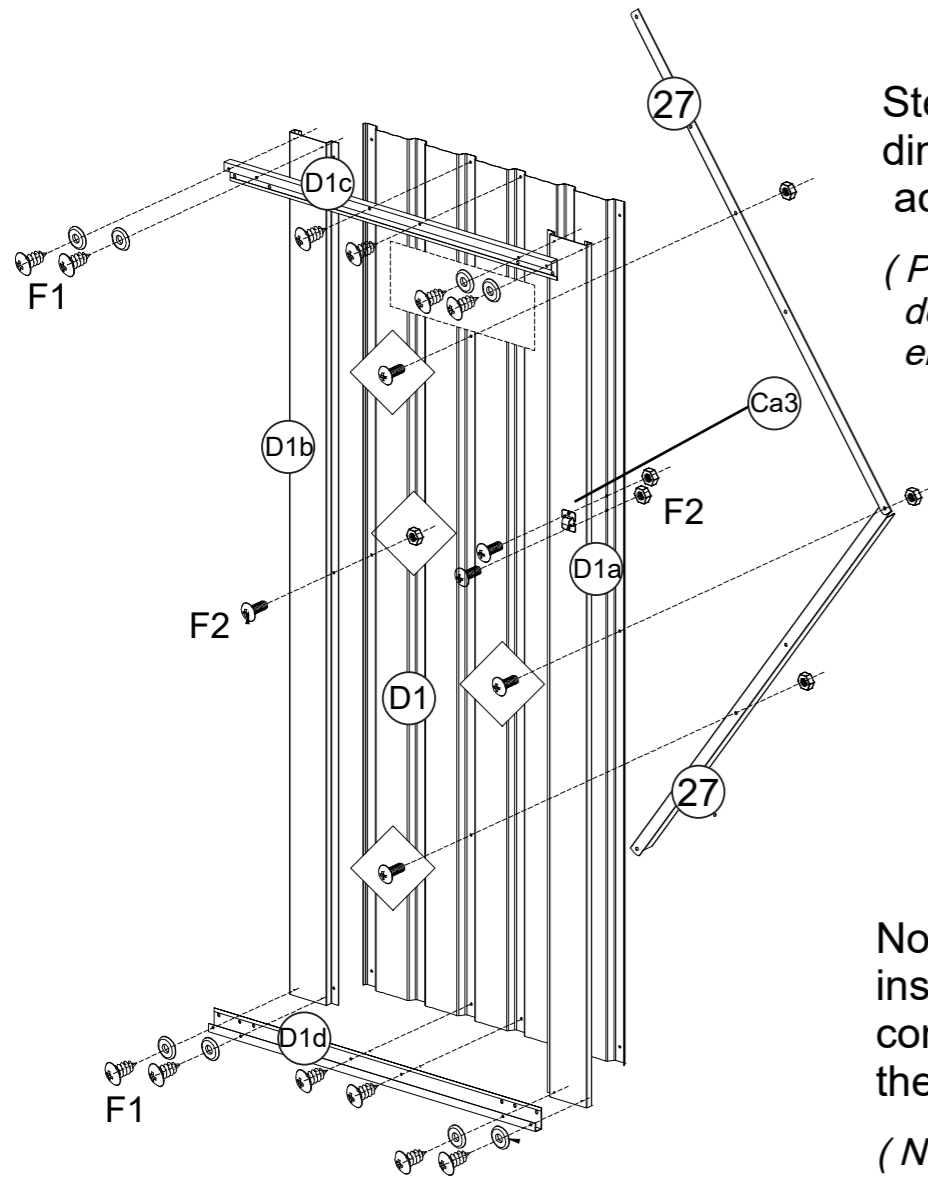

Steps 37 - 40: Board dimensions are subject to actual delivery.

(Pasos 37 - 40: Dimensiones de la tabla están sujetas a la entrega real.)

Note: The procedure for installing the door is quite complicated, please read the instructions carefully.

(Nota: El procedimiento de montaje de la puerta es bastante complicado, por favor, lea atentamente las instrucciones.)

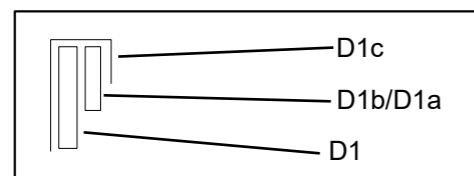





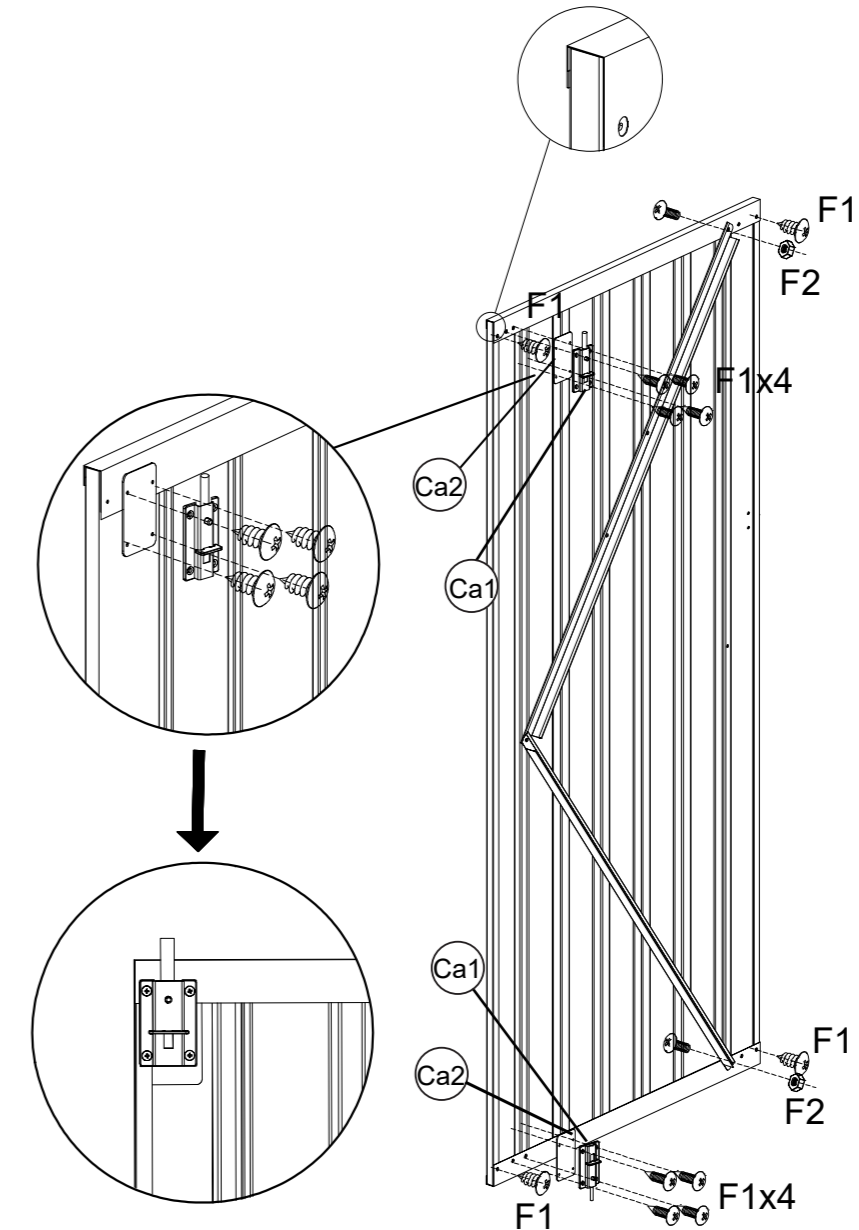

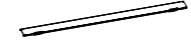

STEP 38/ Paso 38

Ca1		X2	Ca2		X2
F1		X12	F2		X2

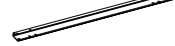

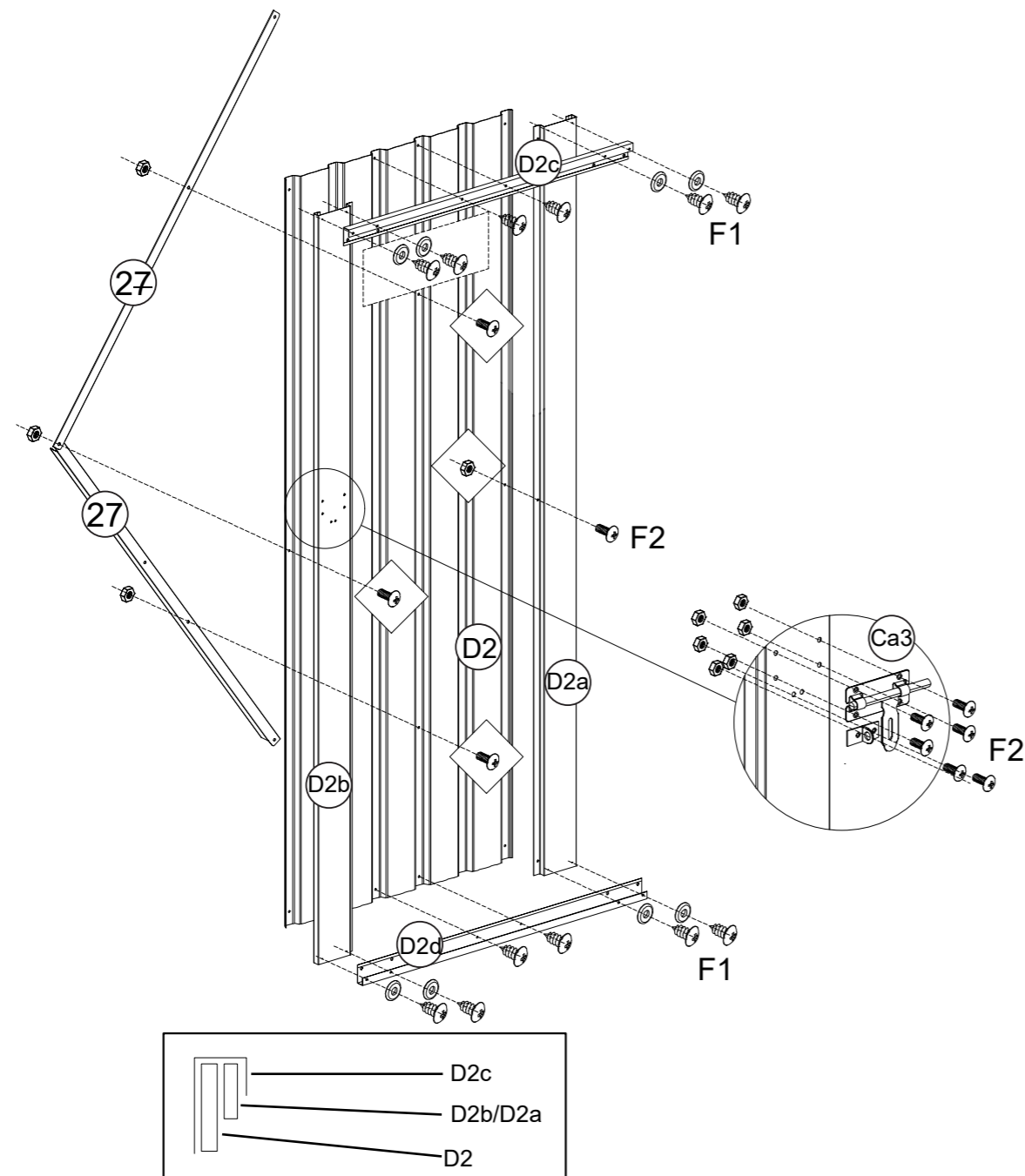

STEP 39/ Paso 39

27		X2	D2		X1
D2a		X1	D2b		X1
D2c		X1	D2d		X1
Ca3		X1	F1		X12
F2		X10	S1		X8



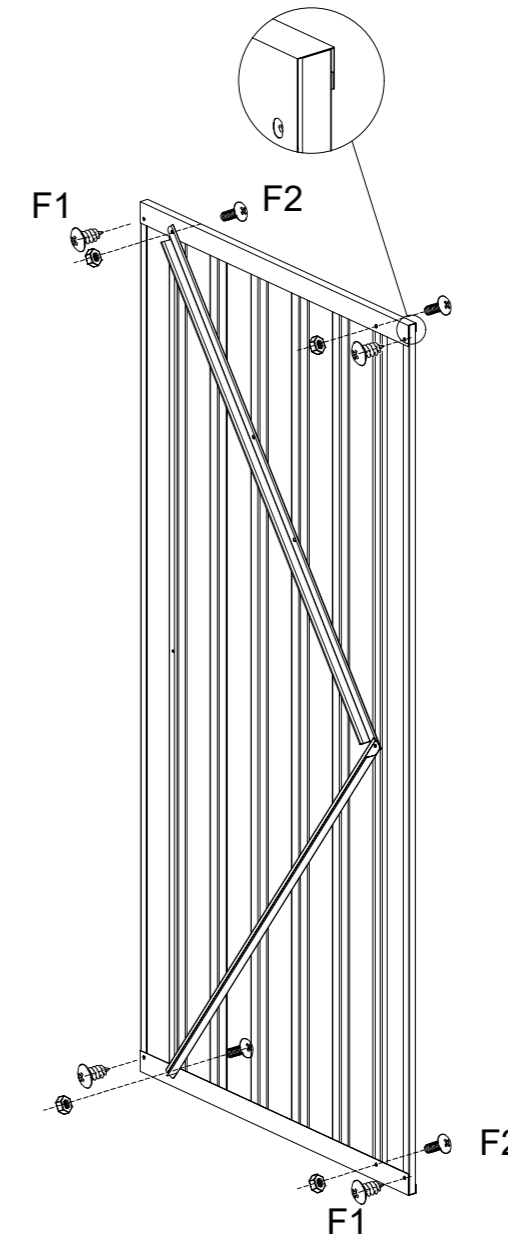

STEP 40/ Paso 40

F1		X4	F2		X4
----	---	----	----	---	----



PRODUCT ASSEMBLY (Ensamblaje del Producto)

STEP 41 / Paso 41

F2		X12	F5		X6
----	---	-----	----	--	----

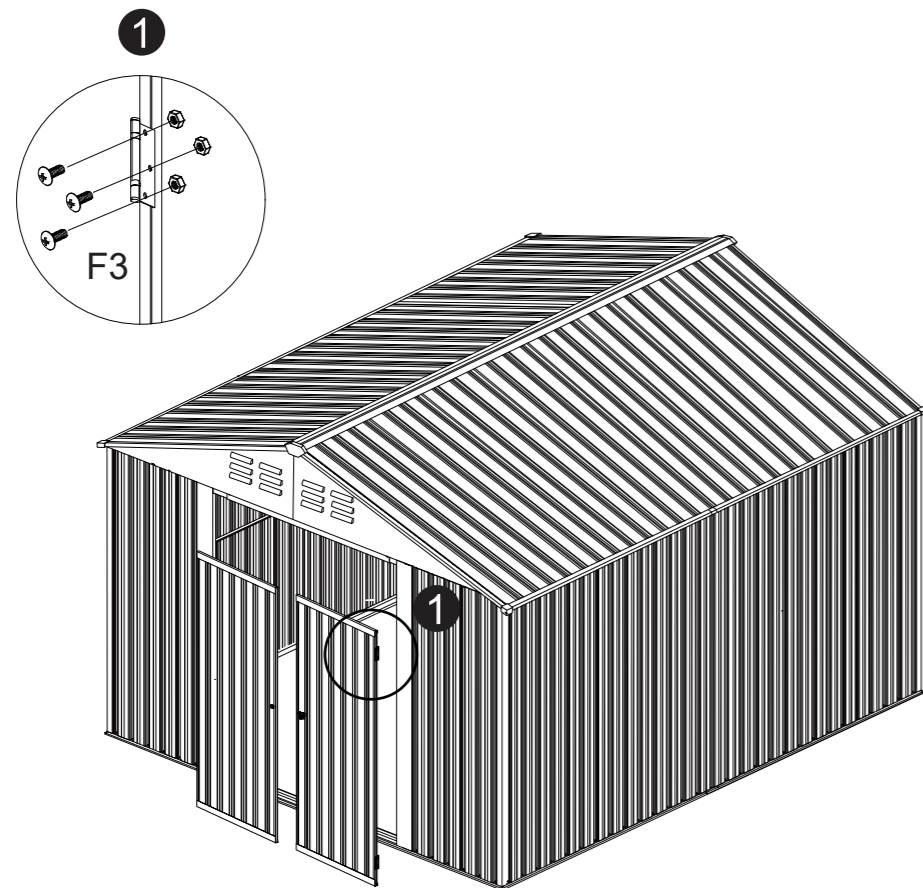

Need to install ground pegs at the 4 corners of the base. The steps are shown in the following picture.

(Los clavos de tierra deben instalarse en las cuatro esquinas de la base. Los pasos se muestran en la siguiente figura.)

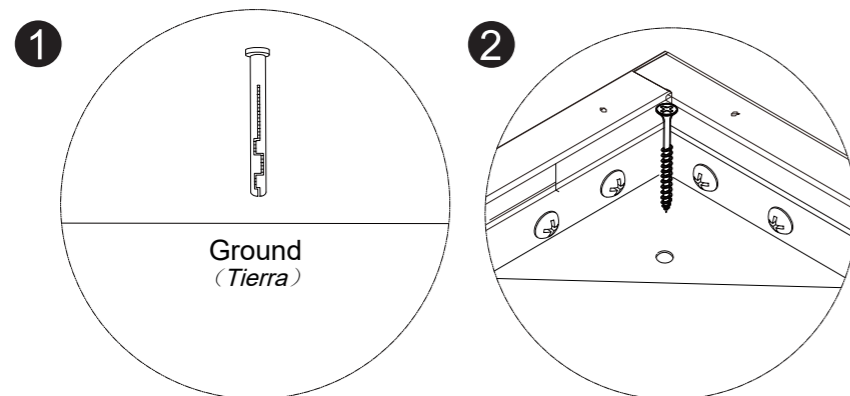

Expansion screws are finally required for both A7 and A5.
(Finalmente, se requieren tornillos de expansión para A7 y A5.)