

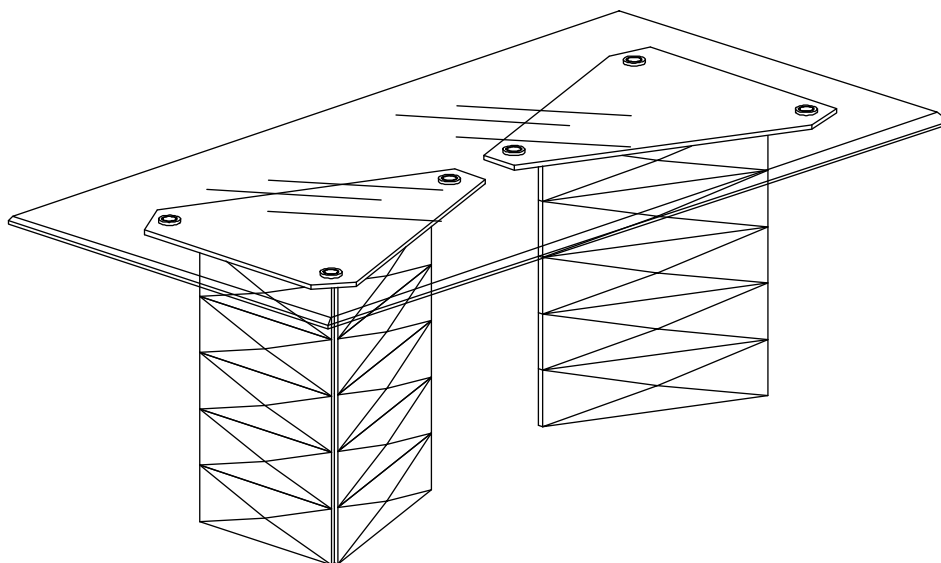

ASSEMBLY INSTRUCTIONS





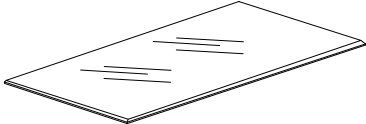
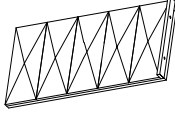

NOTE TO CUSTOMERS:

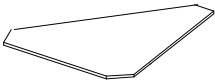
- For ease and speed of assembly we recommend that before you commence each step of the assembly that you identify all the parts required to complete that step.
- We recommend that where possible you allow sufficient space to assemble the item as close as possible to the place where it will be once assembled.
- For the protection of your furniture we recommend that the product is placed on protected surfaces during assembly to prevent any damage.
- During assembly do not over tighten the screws or bolts, as this may damage the product.
- Please ensure you retain all the product packaging until the item is completely assembled.
- Periodically check all fitting and re-tighten as necessary.
- Never allow any liquids to remain on your furniture as absorption can cause the wood to warp or finish to de-laminate.
- It is recommended that this item should be assembled by two adults.

PARTS IDENTIFICATION

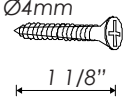
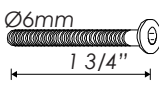
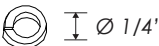
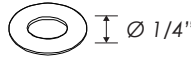
| | | | |
|-----|---------------------|--|--------|
| A- | Glass Top |  | 1 pc |
| B- | Table Base Panel |  | 6 pcs |
| C - | Corner Block |  | 12 pcs |
| D- | Glass Support Panel |  | 2 pcs |

HARDWARE IDENTIFICATION

| | | | |
|----|----------------------------------|---|--------|
| 1- | CSK Screw M4 x 30mm |  | 18 pcs |
| 2- | JCBC Bolt M6 x 45mm |  | 48 pcs |
| 3- | Spring Washer |  | 48 pcs |
| 4- | Flat Washer |  | 24 pcs |
| 5- | Glass Support Ø50 x 10mm |  | 6 pcs |
| 6- | Bolt for Glass Support M6 x 20mm |  | 6 pcs |
| 7- | Allen Key M4 |  | 1 pc |

NOTE: Quantities shown are for one chair. Bolts are metric screw threads

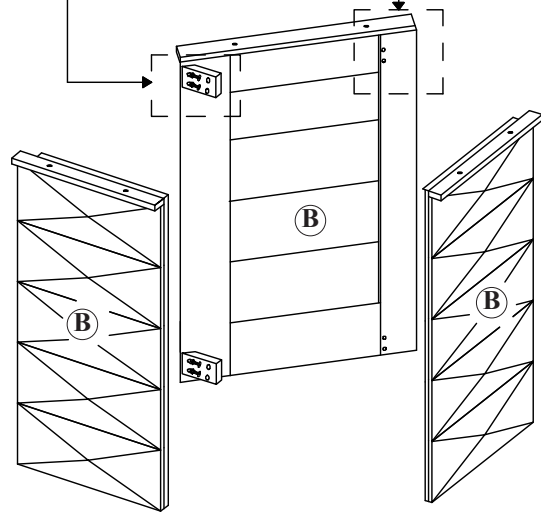
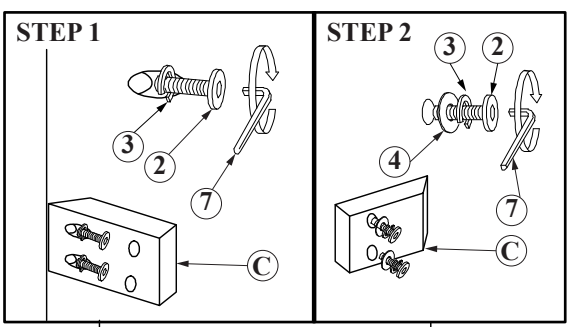

STEP 3

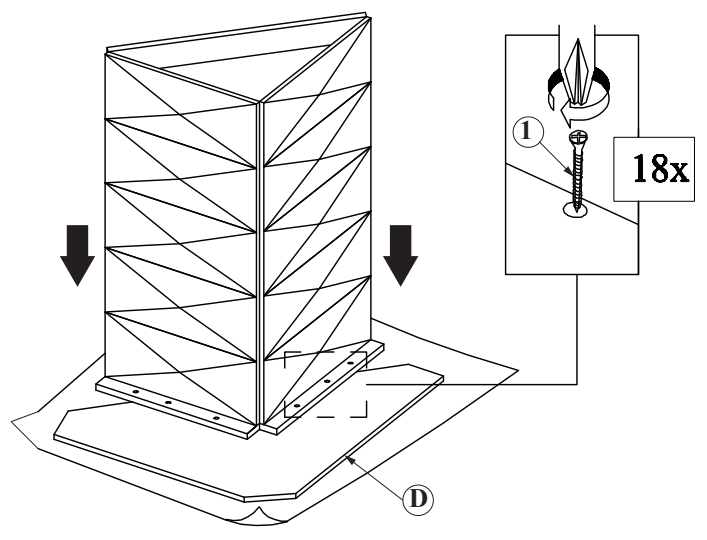

STEP 4 - Turn the table base upright.

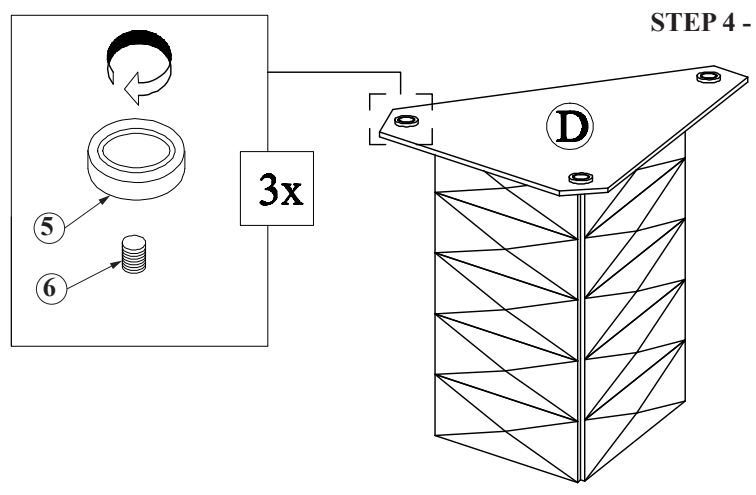

STEP 5 - Carefully place glass top on the table pedestals with help of two adult persons.

