

**CARE AND MAINTENANCE**







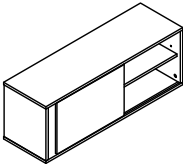
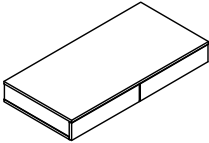
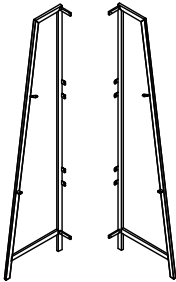
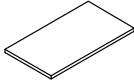
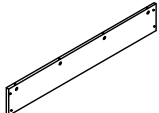

Spot clean using a mild water-free solvent. Only a professional cleaner should undertake a complete overall cleaning.  
The use of steam or water-based cleaners may cause excessive shrinking or staining.

**NOTICE**

- \* Please make sure that you have all parts indicated before you begin assembly of this item
- \* This item should be assembled on a soft surface to prevent scratching the finish during assembly
- \* This item may require periodic tightening

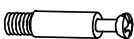
**DIMENSIONS: 39.4"L x 19"D x 70.9"H**

**Part List and Hardware List**

PIECE	DESCRIPTION	PICTURE	QUANTITY
A	body-1		1X
B	body-2		1X
C	metal legs		1X
D	shelf		1X
E	back plant		2X
F	metal bar		2X
HW1	screw M6*1.2*8MM		8X
HW2	screw M6*1.2*14MM		14X
HW3	allen wrench M6		1X
HW4	connecting lever		8X
HW5	fastening		8X
HW6	cover sticker		8X
HW7	shelf supporter		4X

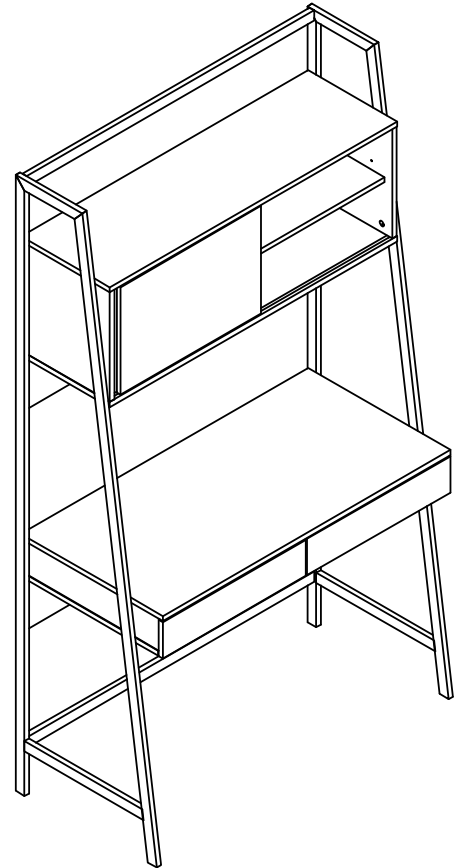

SHELF TOTAL WEIGHT CAPACITY: 110 LBS

**WARNING: DO NOT STAND ON THE SHELF**  
**WARNING: DO NOT OVER TORQUE BOLTS/SCREWS**

## PREPARATION

Before beginning assembly of product, make sure all parts are present. Compare parts with package contents list and hardware contents list.

If any part is missing or damaged, do not attempt to assemble the product.

Estimated Assembly Time: 60 minutes.

Tools Required for Assembly (included): Allen Key

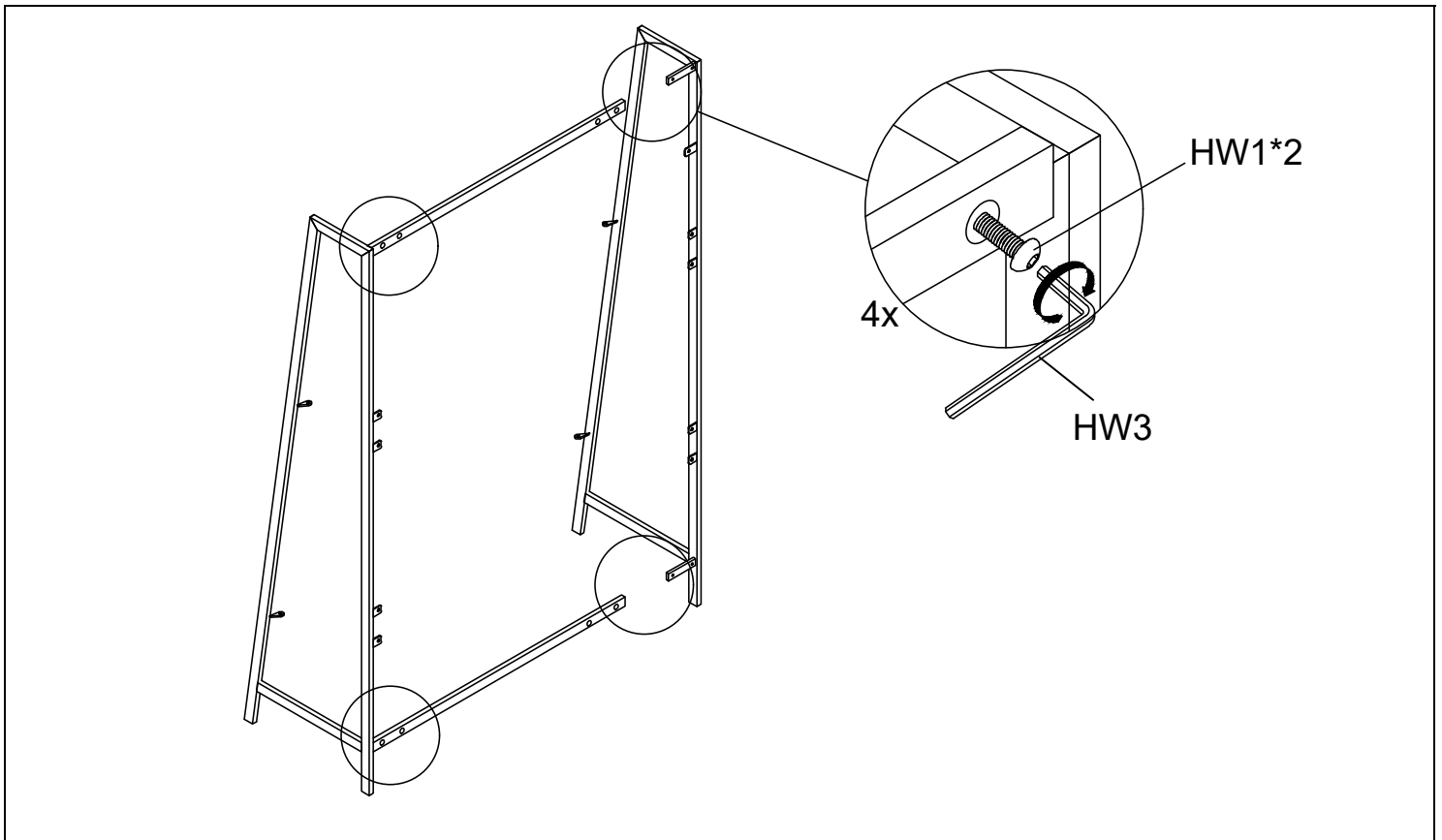

**STEP1** assemble metal legs and metal bars.

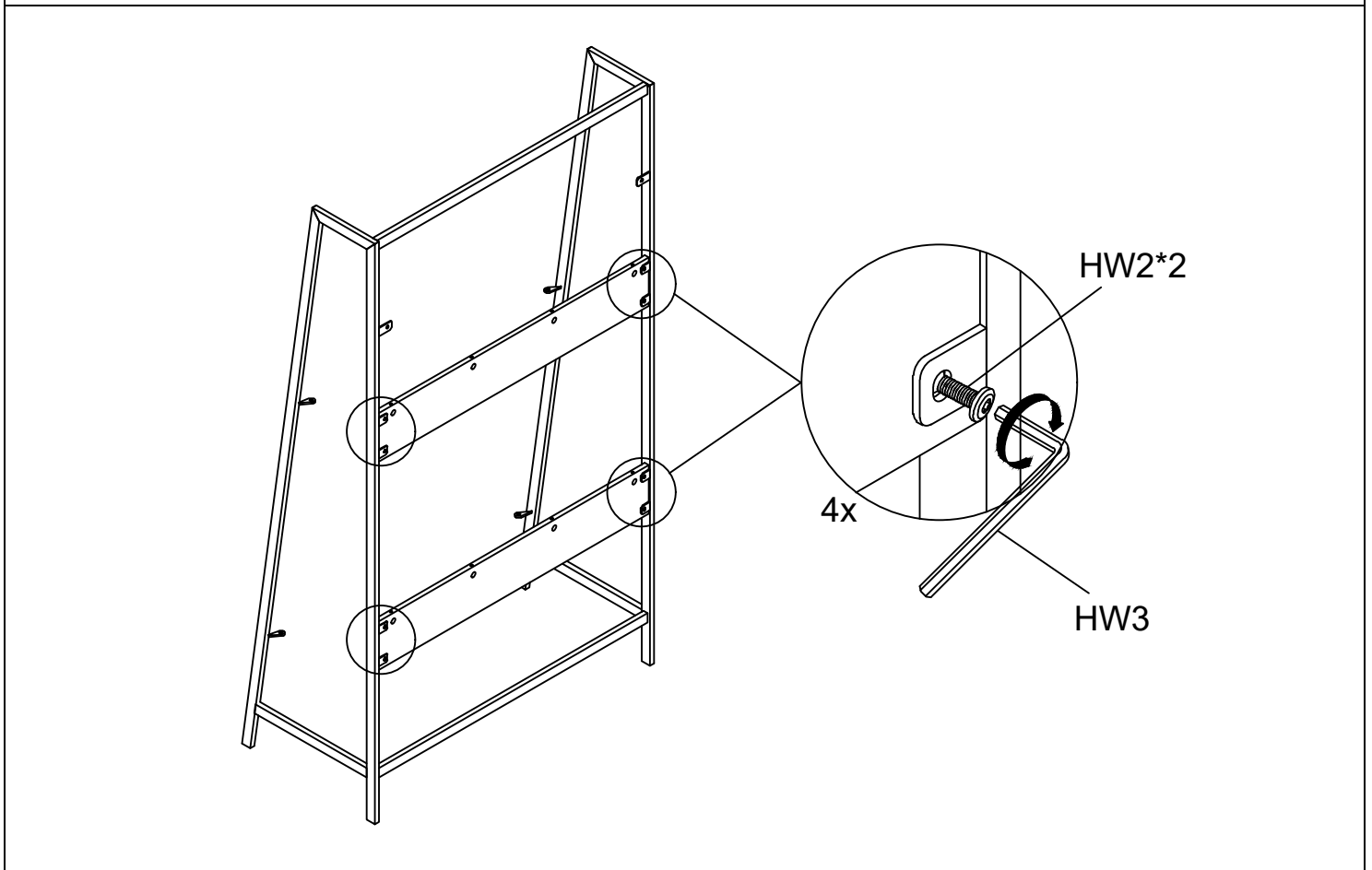

**STEP2** assemble metal bar and the back plant.

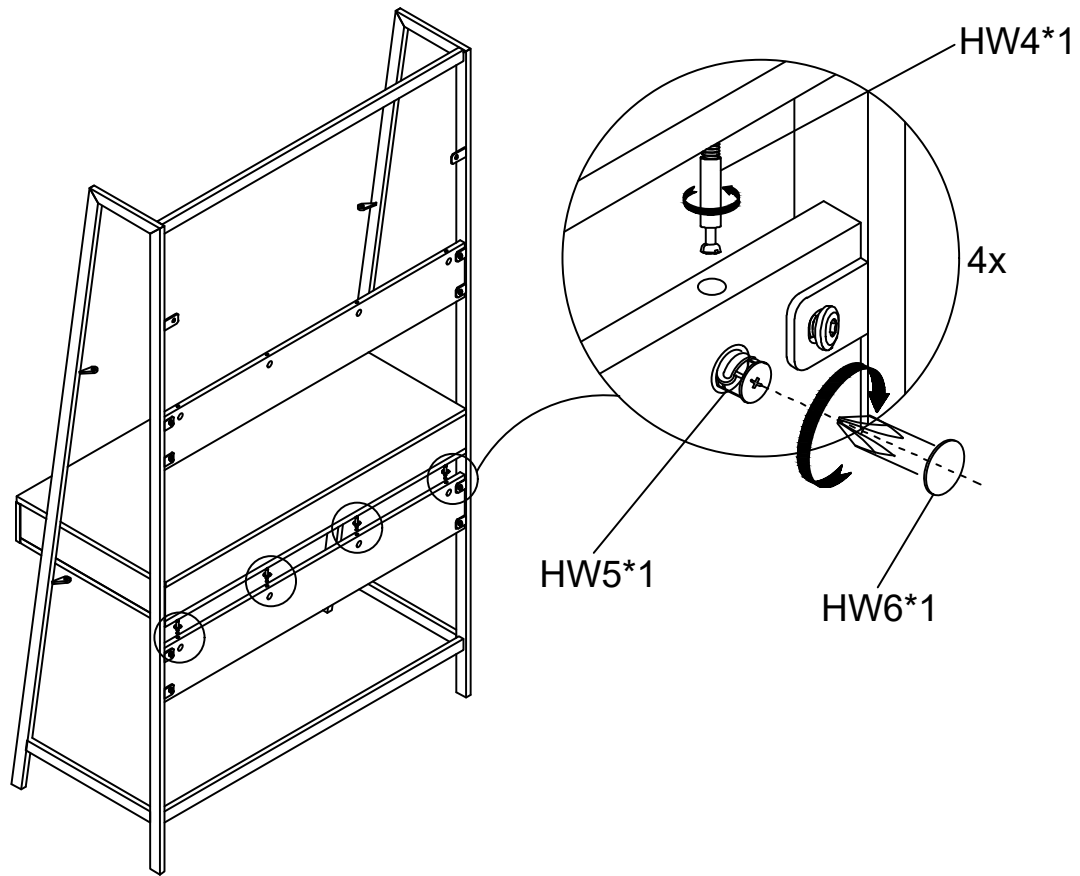

**STEP3** assemble the body-2 and back plant.

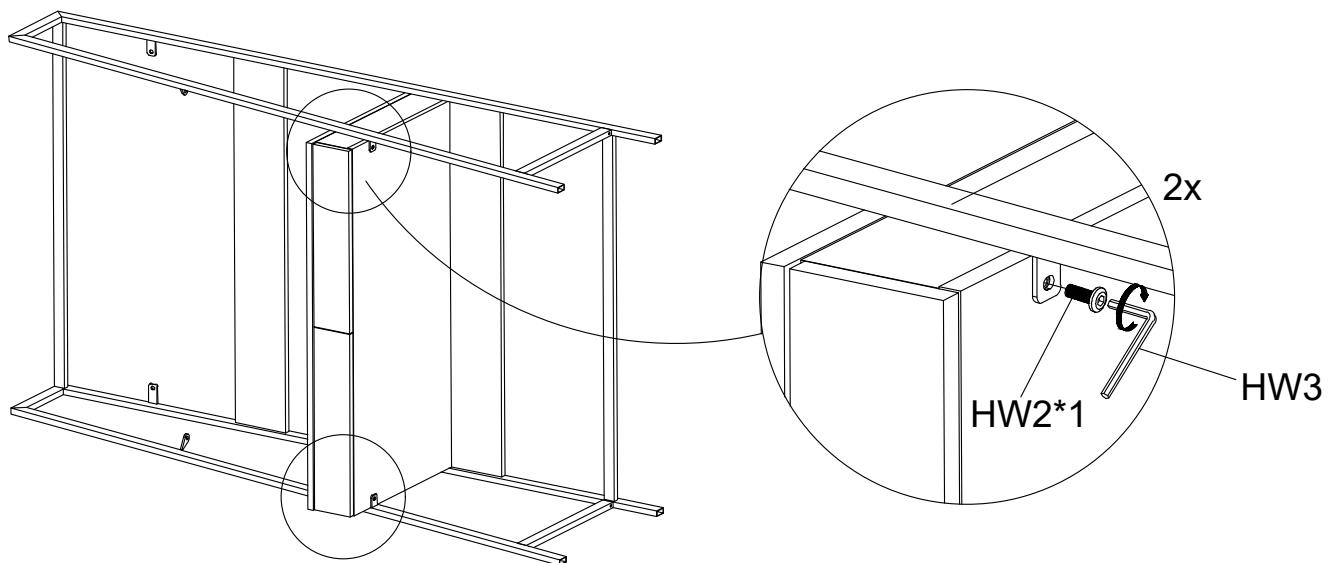

**STEP4** assemble the body-2 and metal legs.

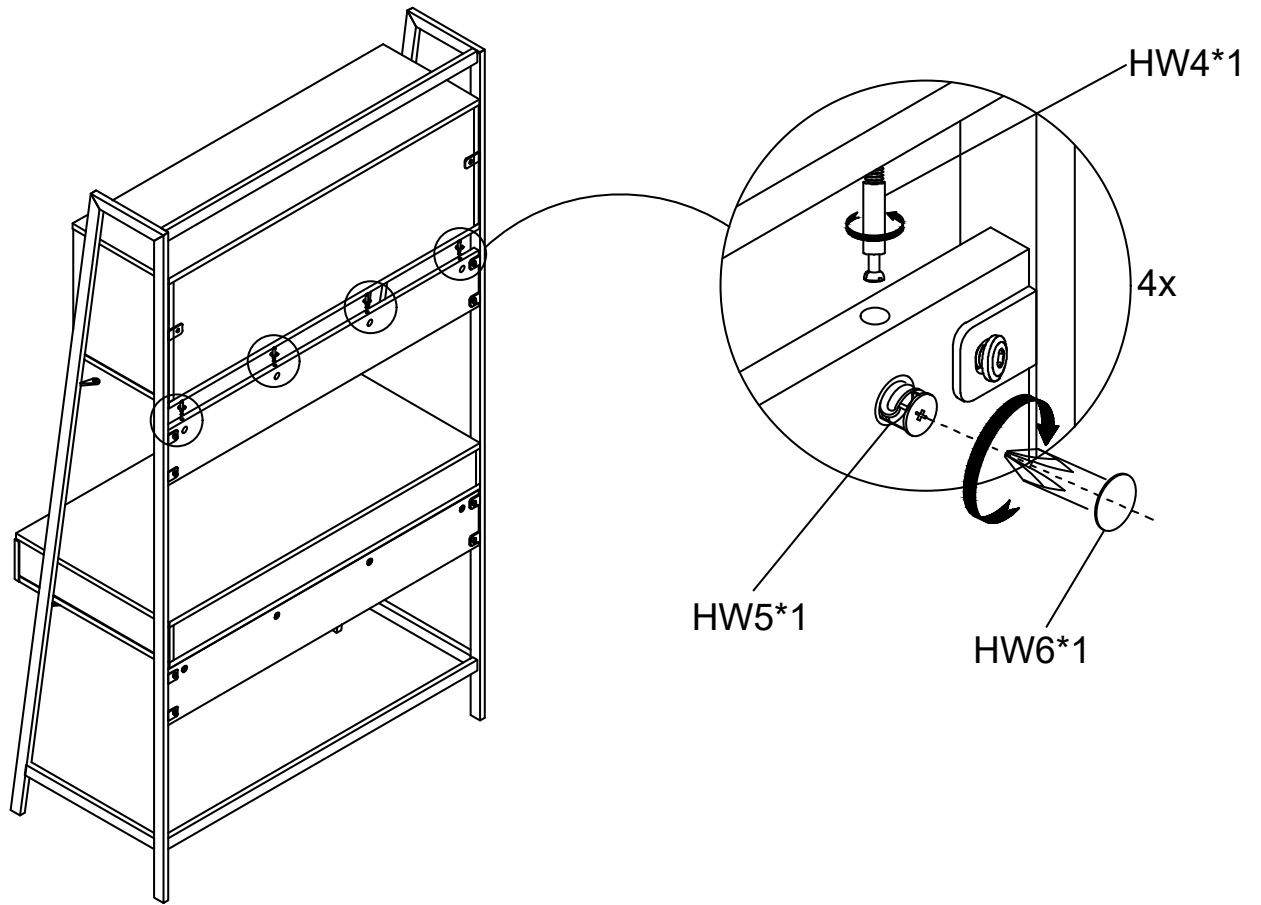

**STEP5** assemble the body-1 and back plant.

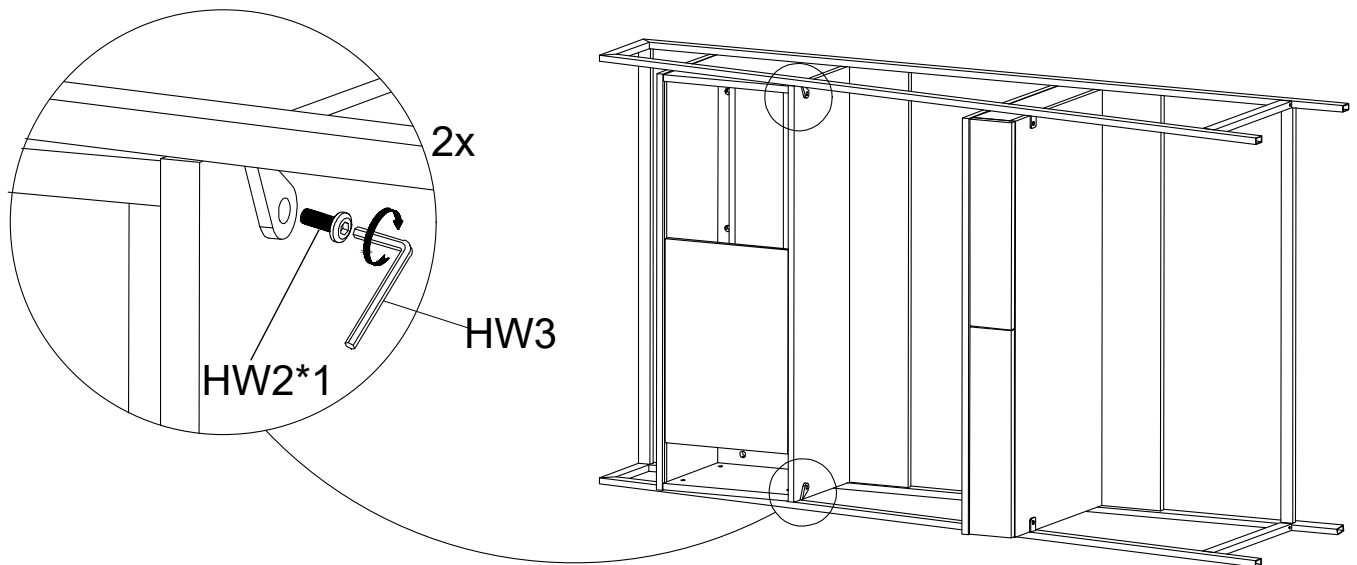

**STEP6** assemble the body-1 and metal legs.

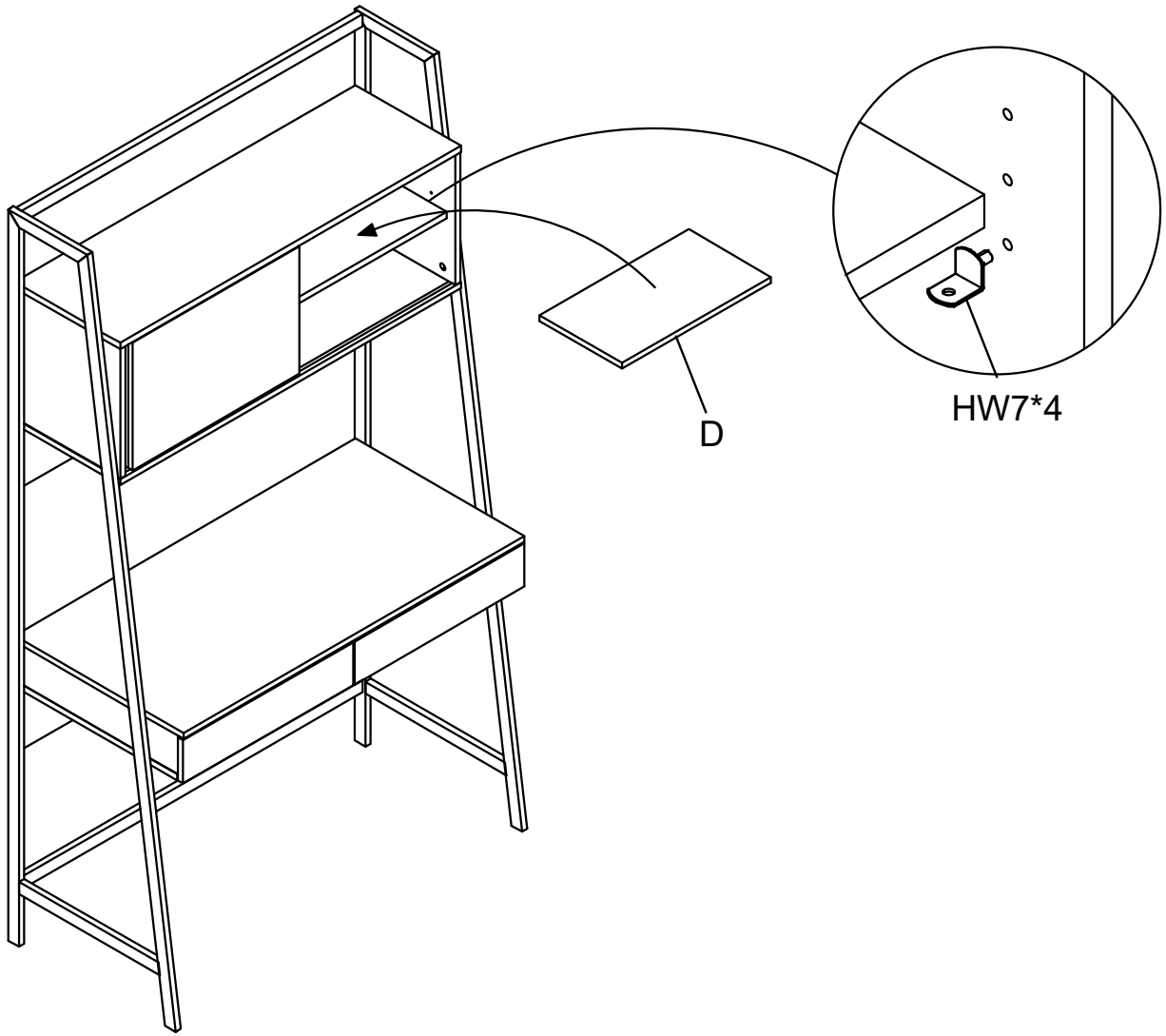

**STEP7** assemble the shelf on the body-1.