

# ASSEMBLY INSTRUCTIONS

SKU CODE: (MF310813)

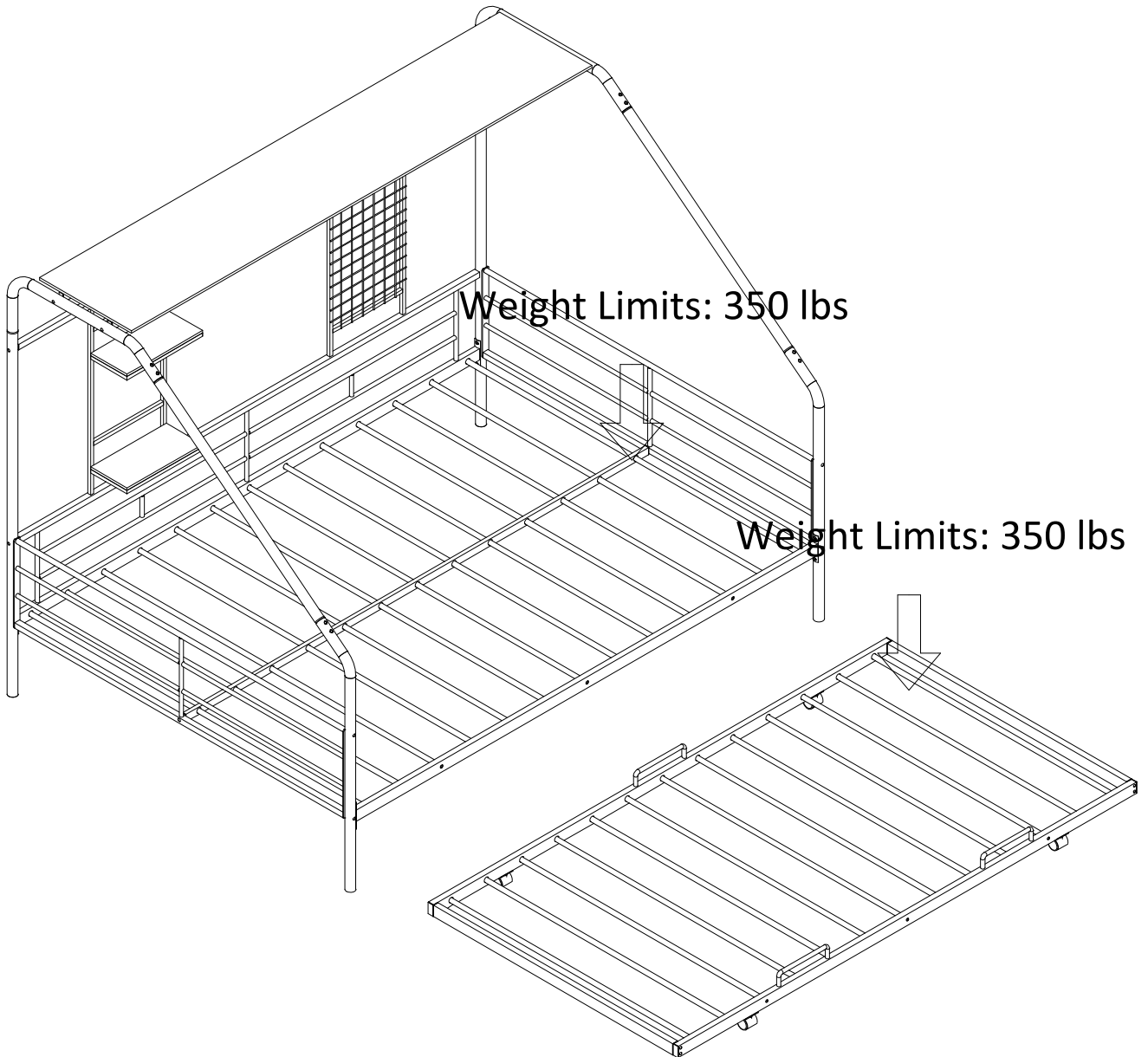

# Detail View

## DAY BED

IMPORTANT:  
PLEASE READ INSTRUCTION BEFORE STARTING THE ASSEMBLY

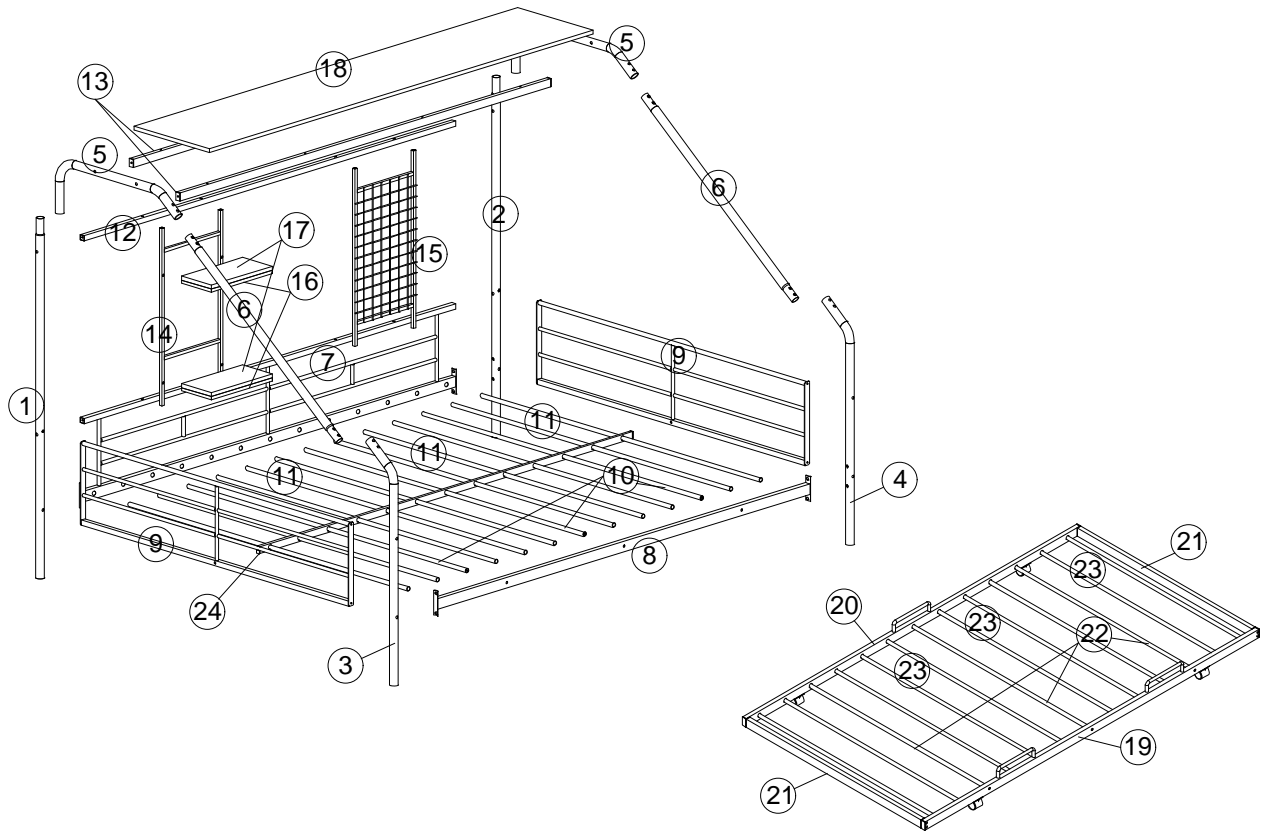

# ASSEMBLY INSTRUCTIONS

## DAY BED

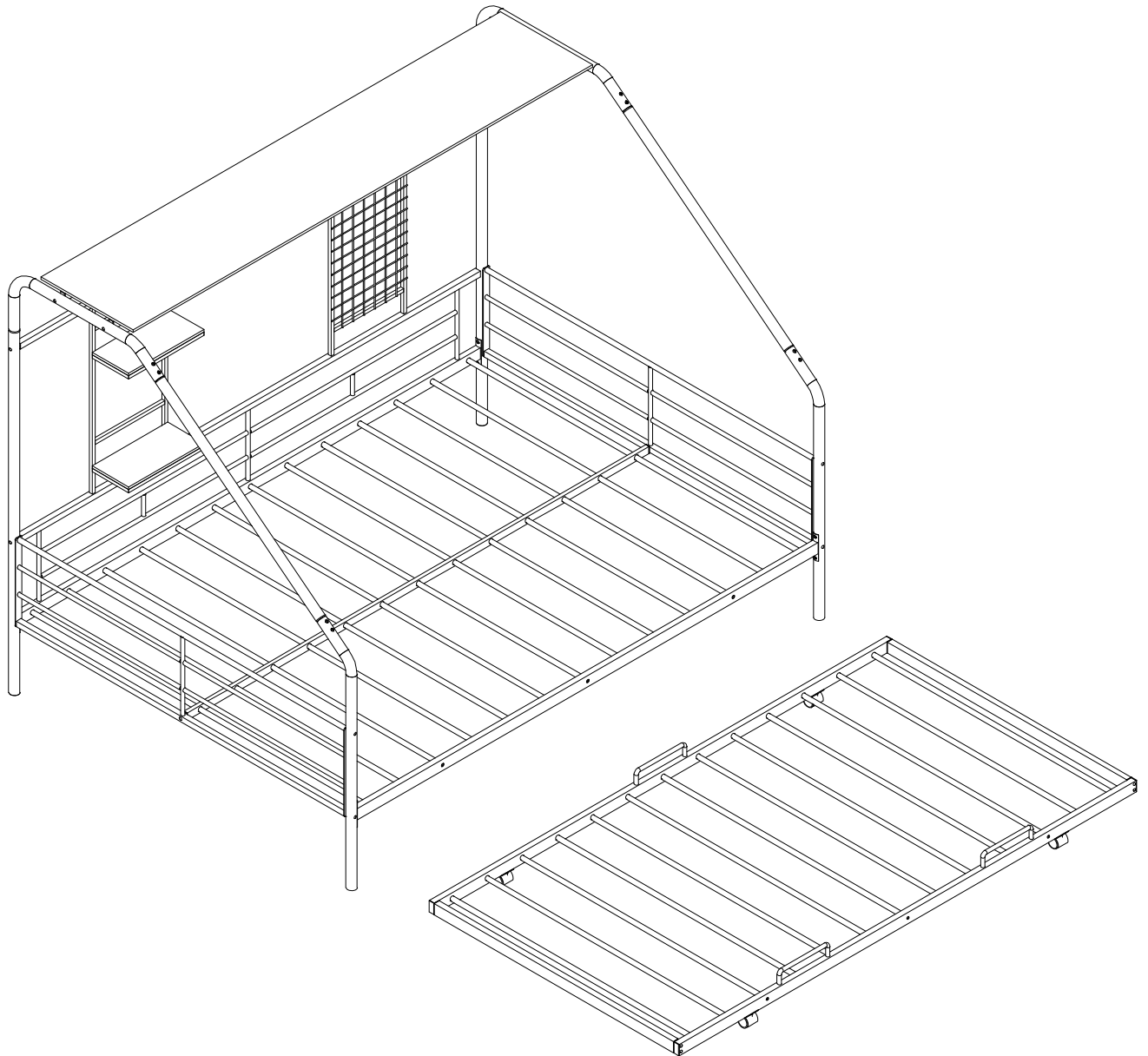













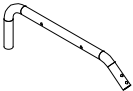
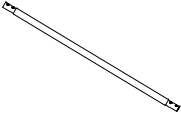
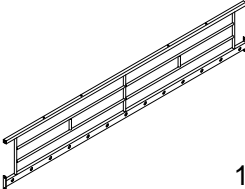
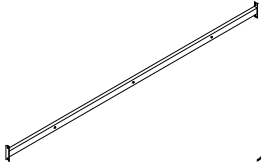
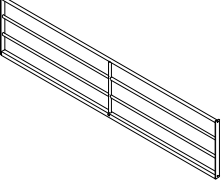

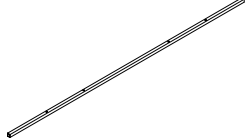
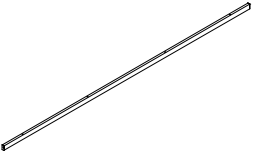
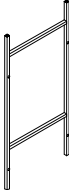
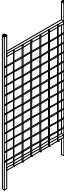
Thank you for purchasing this quality product. Be sure to check all packing material carefully for small parts which may have come loose inside the carton during shipment. Separate, identify and count all parts and hardware.

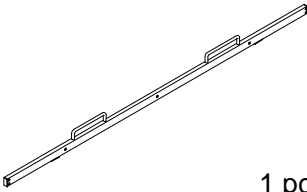
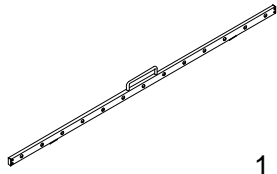
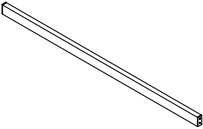

Compare with the parts list to be sure all parts are present.

**"DO NOT TIGHTEN SCREWS UNTIL COMPLETELY ASSEMBLED"**

# PART LIST MF310813

<p>① Vertical Bar</p>  <p>1 pc</p>	<p>② Vertical Bar</p>  <p>1 pc</p>	<p>③ Vertical Bar</p>  <p>1 pc</p>	<p>④ Vertical Bar</p>  <p>1 pc</p>
<p>⑤ Horizontal Bar</p>  <p>2 pcs</p>	<p>⑥ Horizontal Bar</p>  <p>2 pcs</p>	<p>⑦ Guard Frame</p>  <p>1 pc</p>	<p>⑧ Horizontal Bar</p>  <p>1 pc</p>
<p>⑨ Guard Frame</p>  <p>2 pcs</p>	<p>⑩ Slats</p>  <p>3 pcs</p>	<p>⑪ Slats</p>  <p>10 pcs</p>	<p>⑫ Horizontal Bar</p>  <p>1 pc</p>
<p>⑬ Horizontal Bar</p>  <p>2 pcs</p>	<p>⑭ Frame</p>  <p>1 pc</p>	<p>⑮ Frame</p>  <p>1 pc</p>	<p>⑯ Frame</p>  <p>2 pcs</p>
<p>⑰ Plank</p>  <p>2 pcs</p>	<p>⑱ Plank</p>  <p>1 pc</p>	<p>⑲ Horizontal Bar</p>  <p>1 pc</p>	<p>⑳ Horizontal Bar</p>  <p>1 pc</p>
<p>㉑ Horizontal Bar</p>  <p>2 pcs</p>	<p>㉒ Slats</p>  <p>3 pcs</p>	<p>㉓ Slats</p>  <p>10 pcs</p>	<p>㉔ Horizontal Bar</p>  <p>1 pc</p>

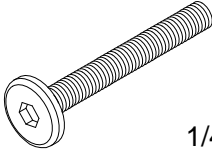
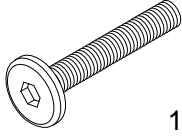
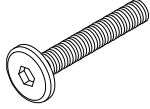
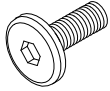
# HARDWARE LIST MF310813

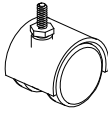
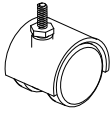
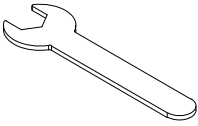
<p>(A) Bolts</p>  <p>1/4*50 16 pcs</p>	<p>(B) Bolts</p>  <p>1/4*40 20 pcs</p>	<p>(C) Bolts</p>  <p>1/4*32 2pcs</p>	<p>(D) Bolts</p>  <p>1/4*18 32 pcs</p>
<p>(E) Bolts</p>  <p>#8*10 16 pcs</p>	<p>(F) Screws</p>  <p>4*59 1 pc</p>	<p>(G) Caster</p>  <p>2 pcs</p>	<p>(H) Locking Caster</p>  <p>2 pcs</p>
<p>(I) Wrench</p>  <p>13*90 1 pc</p>			

# DAY BED ASSEMBLY INSTRUCTIONS ITEM: MF310813

## STEP 1

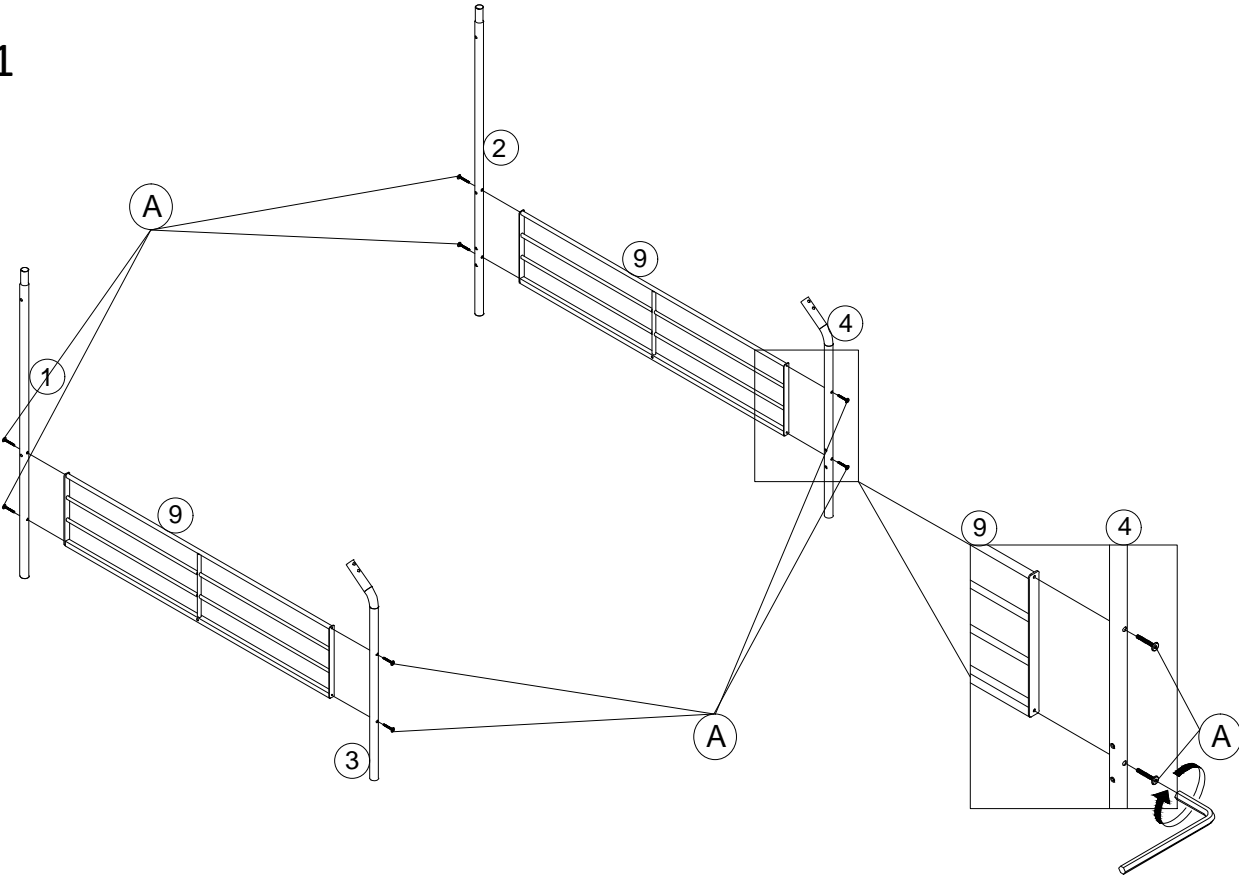

A		1/4*50	8 pcs
---	---	--------	-------

## STEP 2

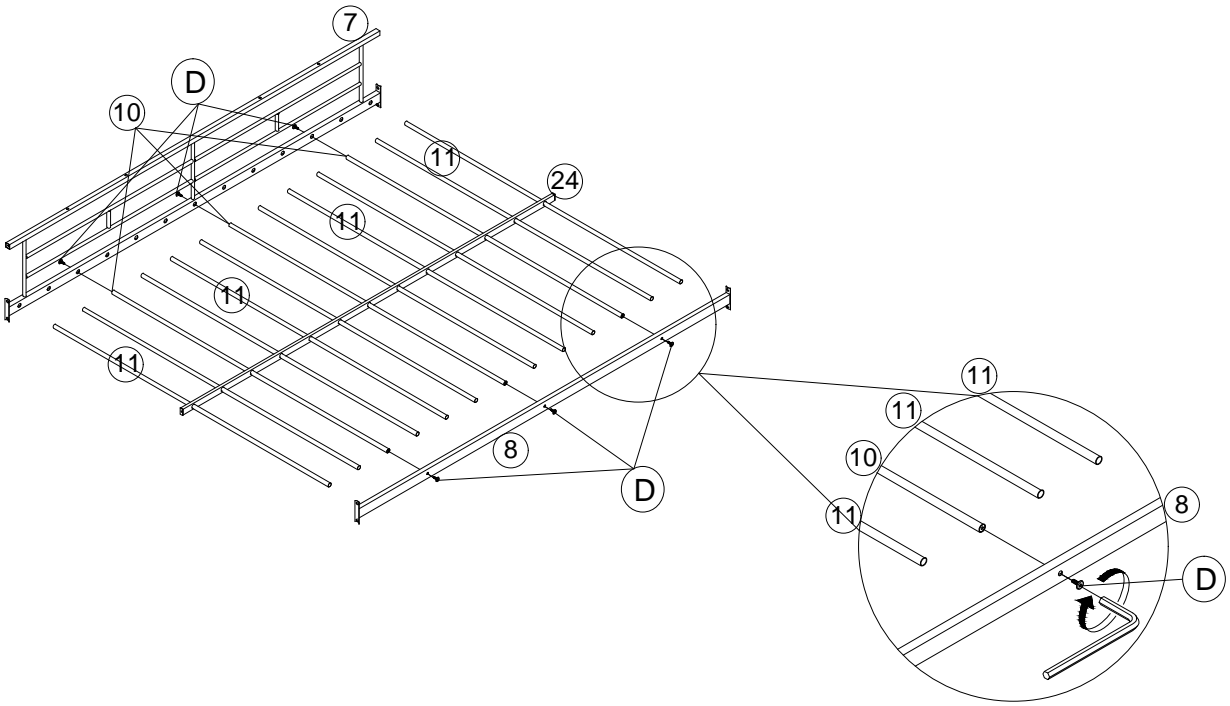



D		1/4*18	6 pcs
---	---	--------	-------

# DAY BED ASSEMBLY INSTRUCTIONS ITEM: MF310813

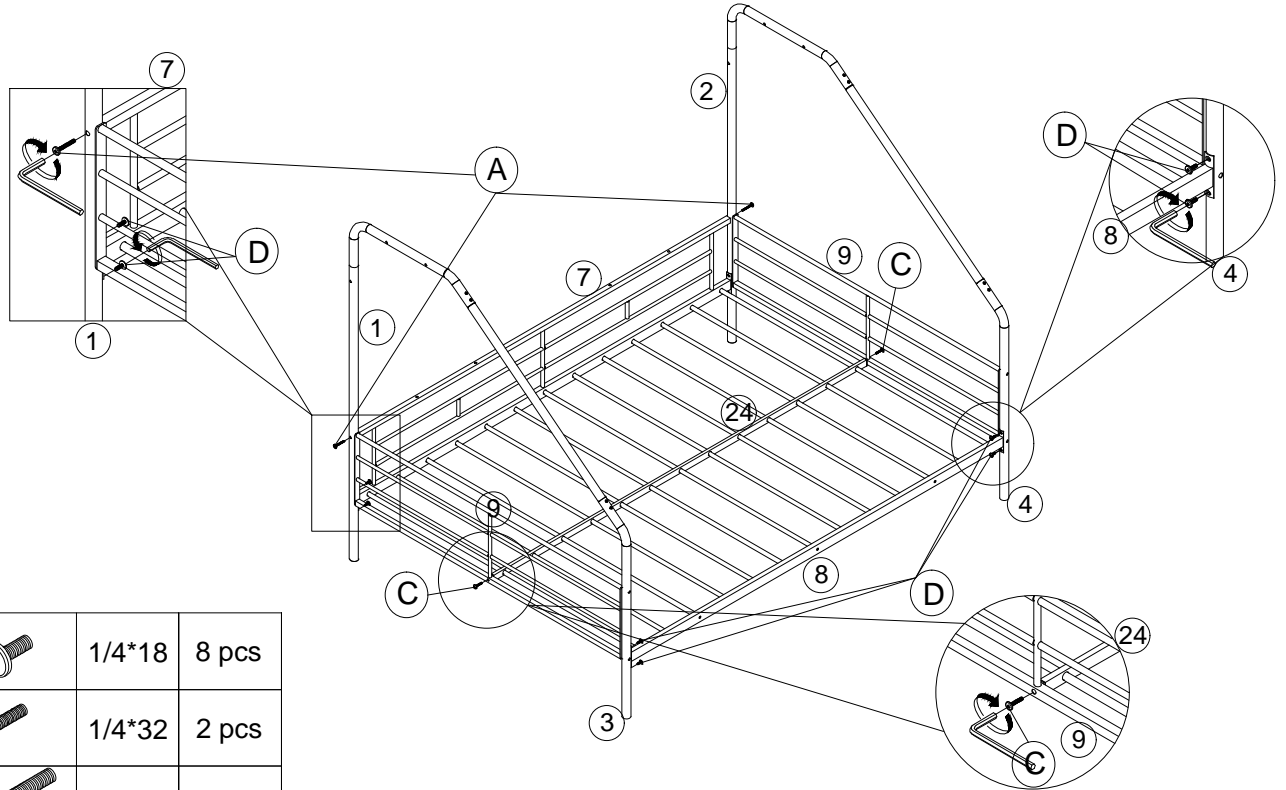
## STEP 3

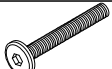

D		1/4*18	8 pcs
C		1/4*32	2 pcs
A		1/4*50	2 pcs

## STEP 4

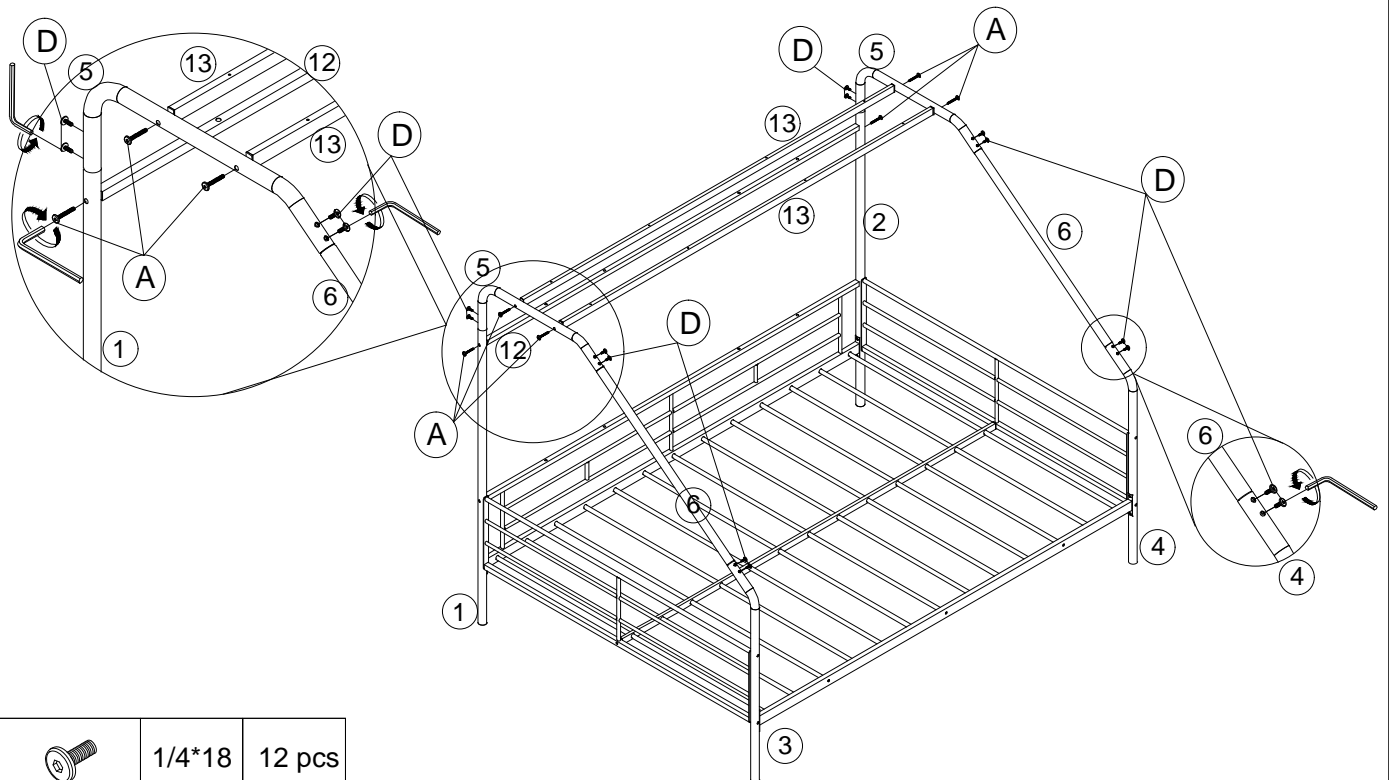

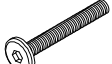
D		1/4*18	12 pcs
A		1/4*50	6 pcs

# DAY BED ASSEMBLY INSTRUCTIONS ITEM: MF310813

## STEP 5

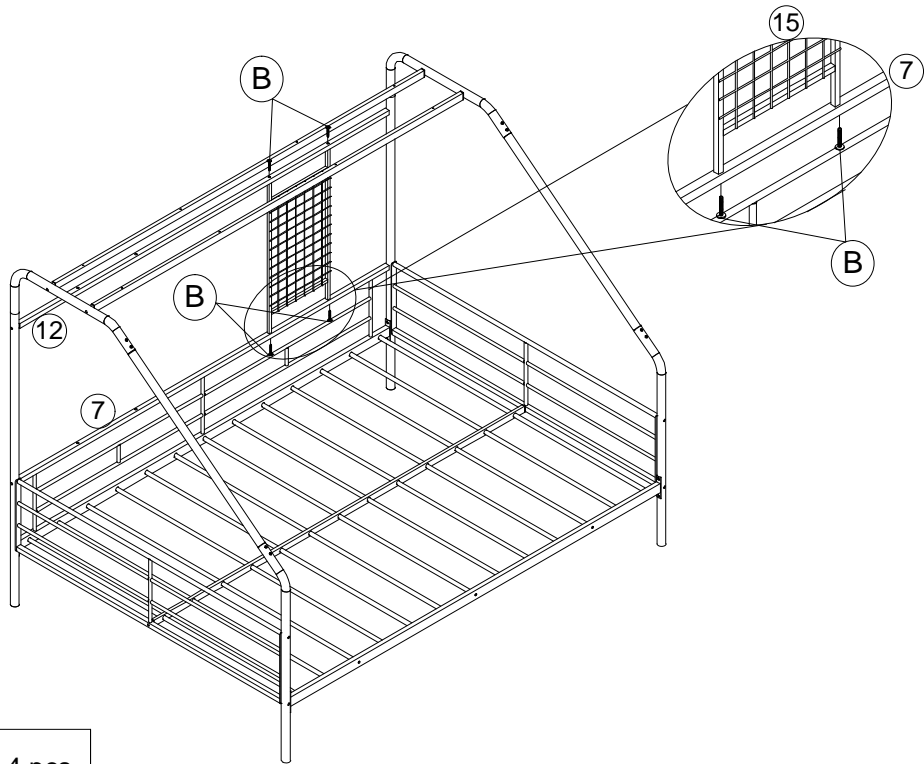

(B)		1/4*40	4 pcs
-----	---	--------	-------

## STEP 6

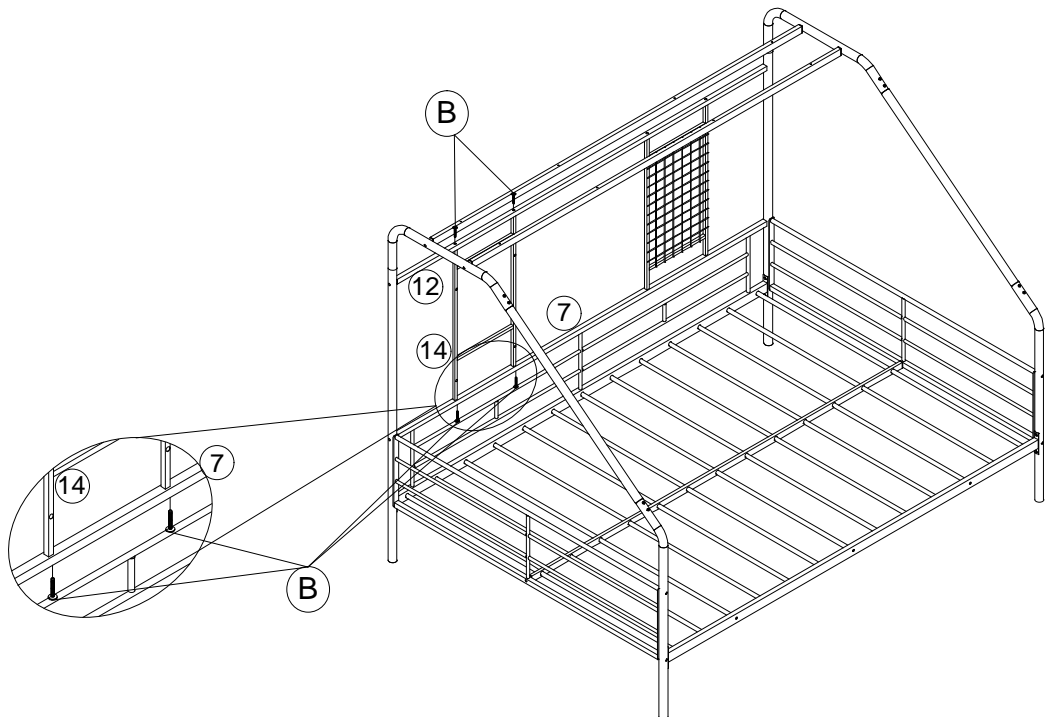

(B)		1/4*40	4 pcs
-----	---	--------	-------

# DAY BED ASSEMBLY INSTRUCTIONS ITEM: MF310813

## STEP 7 x2

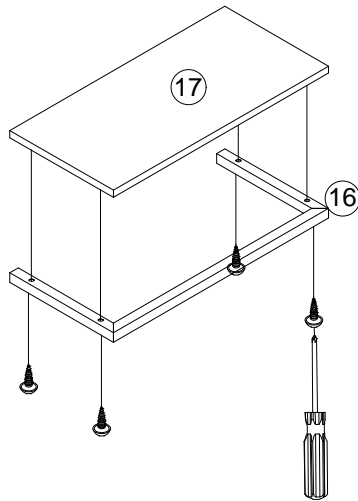

E



#8\*10

4 pcs x2

## STEP 8

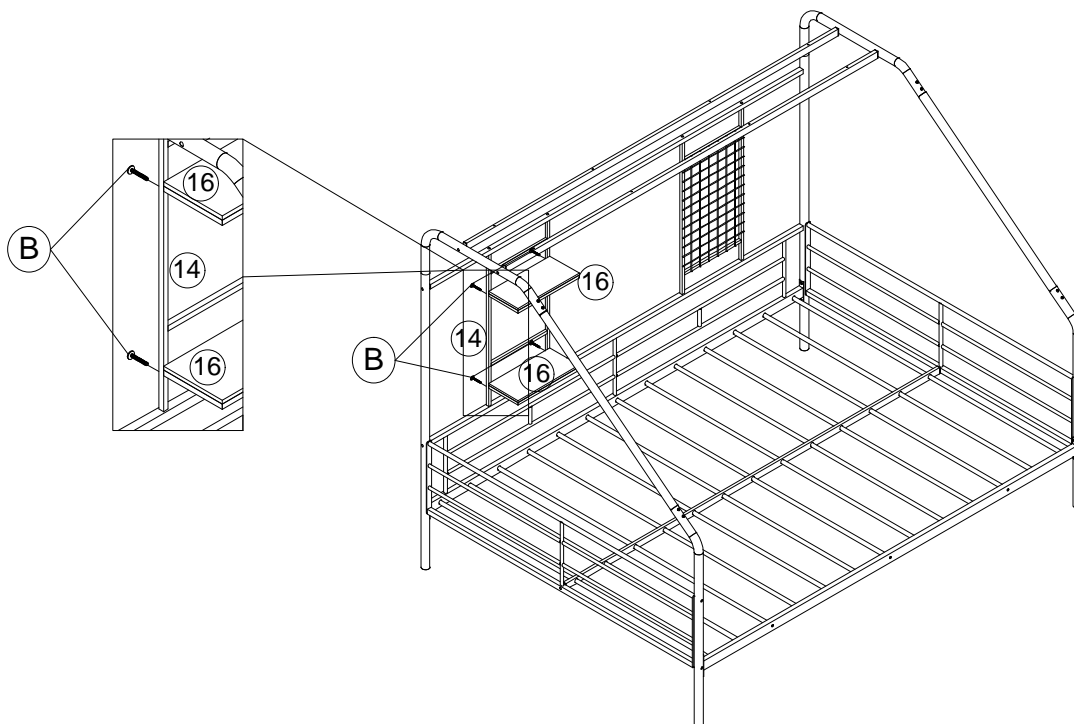

B



1/4\*40

4 pcs

# DAY BED

## ASSEMBLY INSTRUCTIONS

### ITEM: MF310813

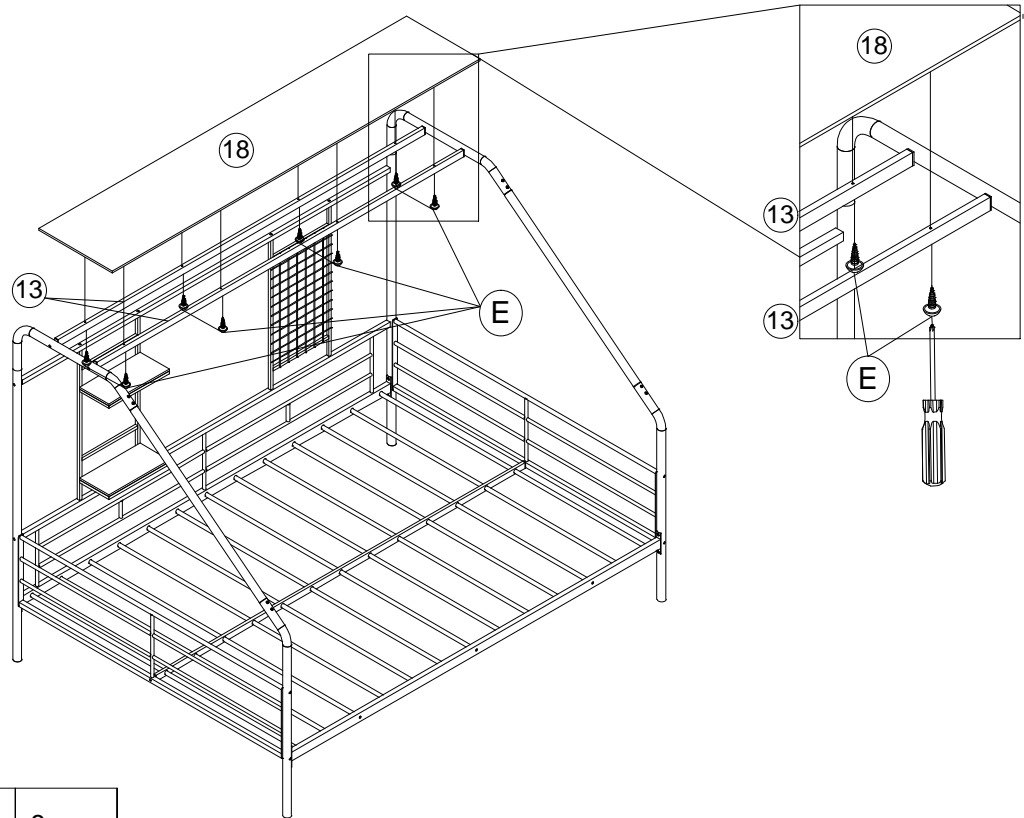

#### STEP 9

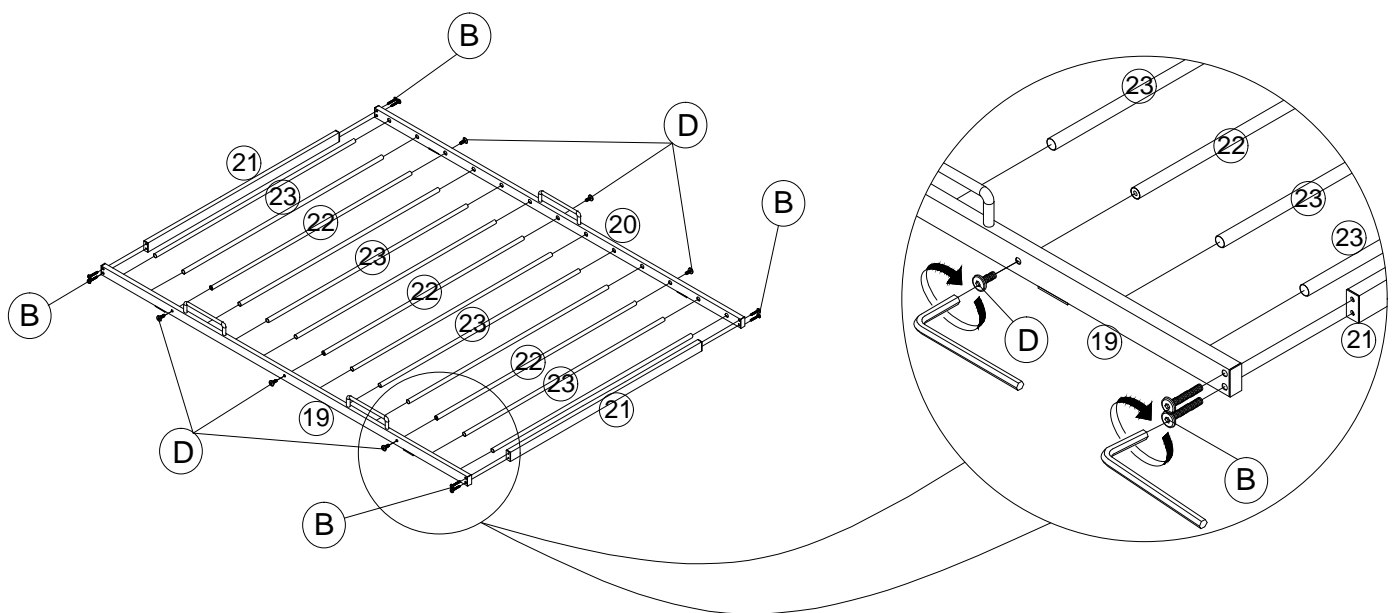

E		#8*10	8 pcs
---	---	-------	-------

#### STEP 10



D		1/4*18	6 pcs
B		1/4*40	8 pcs

DAY BED  
ASSEMBLY INSTRUCTIONS  
ITEM: MF310813

STEP 11

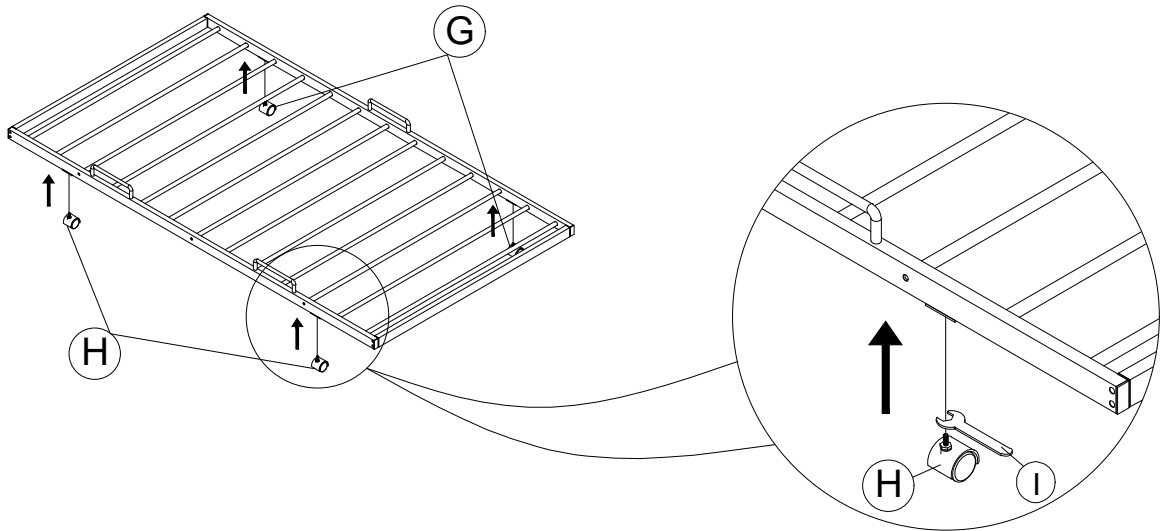

COMPLETE

