

# Assembly Instructions

## Corner Coat Rack

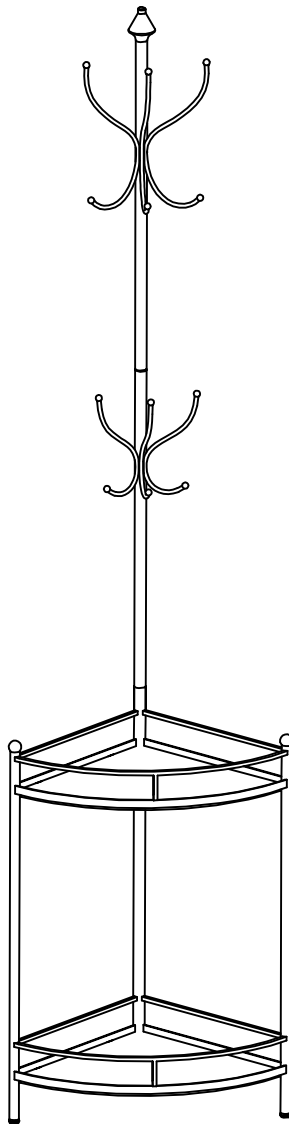



## Before you start to assemble this coat rack:

- Remove all pieces from the box.
- The flatted carton can be used as a work surface during assembly.
- Gather all tools needed for assembly.
- For ease and speed of assembly we recommend that before you commence each step of the assembly that you identify all the parts required to complete that step.
- For the protection of your furniture we recommend that the product is placed on protected surfaces during assembly to prevent any damage.
- During assembly do not over tighten, as this may damage the product.
- Please ensure you retain all the product packaging until the item completely assembled.
- Please periodically check all fittings and re-tighten as necessary.
- It is recommended that this item should be assembled by two adults.
- Weight capacity of each shelf 10lbs, weight capacity of each hook 5lbs.

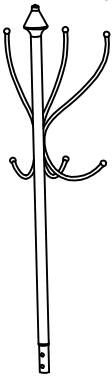
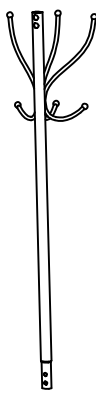
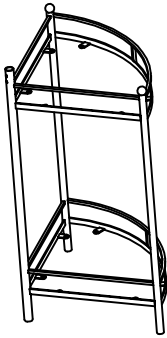

## WARNING

- Do not let any sharp objects touch or rub the surface of the product.
- When assembling, do not let children around the working area.
- Please confirm all parts are correct before starting the assembly process.
- Do not tighten all bolts and screws completely until the entire unit has been assembled and set up.
- Use only the hex wrench provided (B3). **DO NOT USE POWER TOOLS.**  
**Power tools can overtighten screws and strip threads.**  
**DO NOT OVERTIGHTEN.**

## Part List

|   |  |   |   |
|---|--|---|---|
| <p><b>A1</b>                      Quantity of 1</p>  <p>Top Pole</p> | <p><b>A2</b>                      Quantity of 1</p>  <p>Middle Pole</p> | <p><b>A3</b>                      Quantity of 1</p>  <p>Bottom Frame</p> | <p><b>A4</b>                      Quantity of 2</p>  <p>Shelf</p> |
|---|--|---|---|

## Hardware List

|   |   |  |  |
|---|---|--|--|
| <p><b>B1</b>                      Quantity of 4</p>  <p>Bolt</p> | <p><b>B2</b>                      Quantity of 12</p>  <p>Screw</p> | <p><b>B3</b>                      Quantity of 1</p>  <p>Allen Wrench</p> |  |
|---|---|--|--|

Tool required: Phillips screwdriver.

## STEP 1                      Assembly instructions

**B2**  12pcs

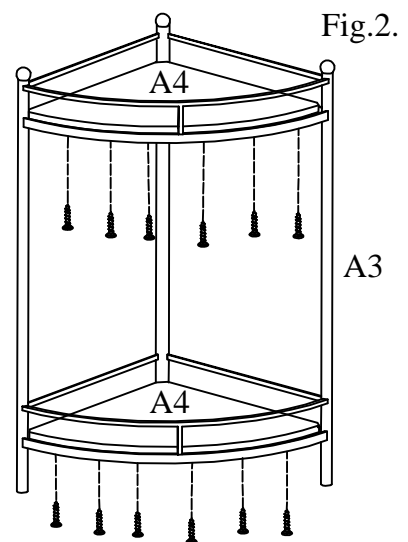
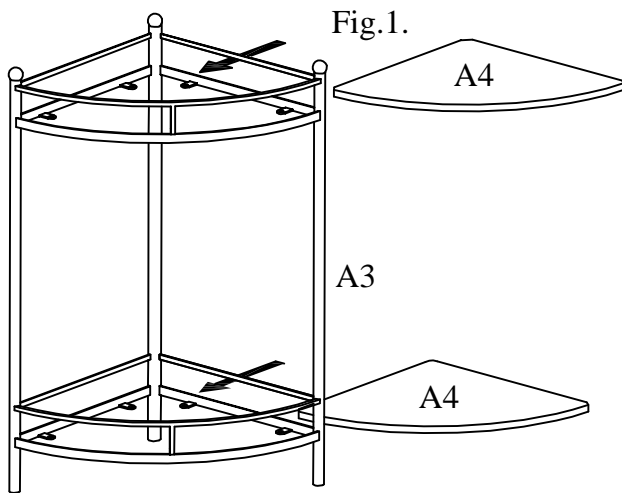

- 1). Insert Shelves A4 from the side of Bottom Frame A3 refer Fig.1.
  - 2). Then assemble Shelves A4 to Bottom Frame A3 using Screws B2 refer Fig.2.
- Note: Holes are pre-drilled for screws B2.

## STEP 2

B1  4pcs

B3  1pc

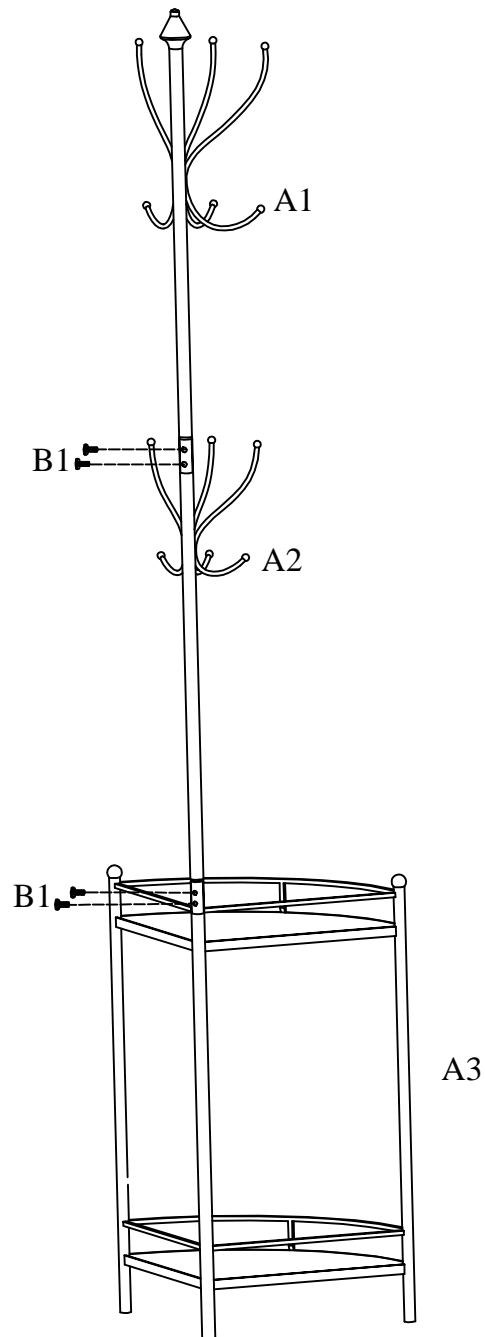

- 1). Insert Middle Pole A2 into Bottom Frame A3, then using Bolts B1 to tighten A2 & A3 as shown above.
- 2). Insert Top Pole A1 into Middle Pole A2, then using Bolts B1 to tighten A1 & A2 as shown above.