

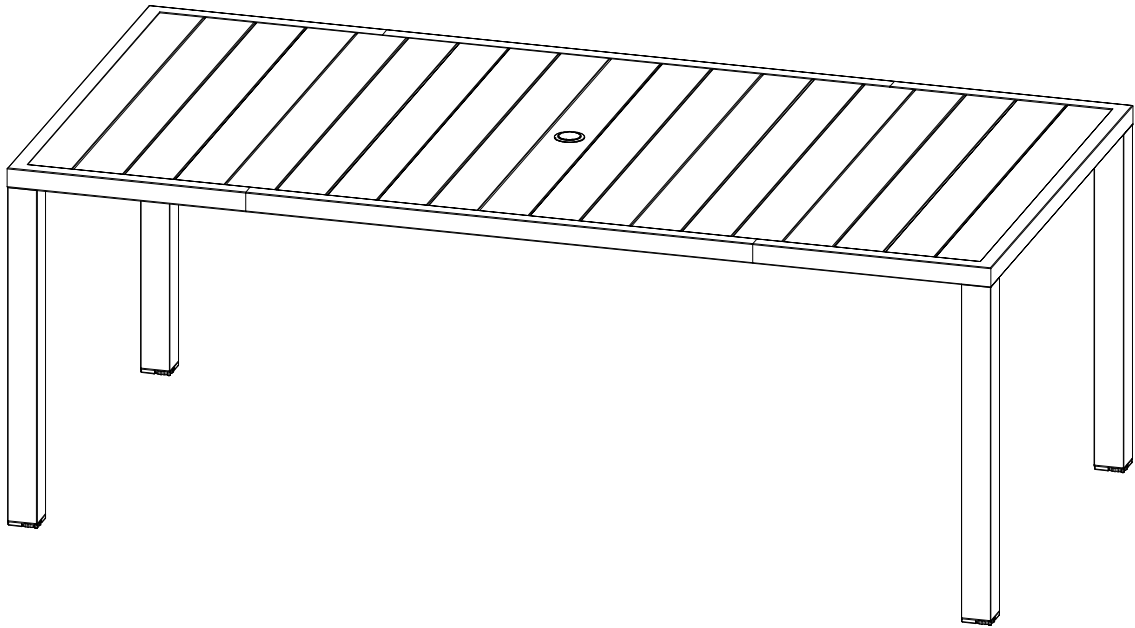

Metal Dining Table Assembly Manual



MODEL#: LTCF5451

Missing part? Damaged? Contact us via email at

service@domioutdoorliving.com

www.domioutdoorliving.com



READ & SAVE BELOW INSTRUCTIONS BEFORE ASSEMBLY

1. PLEASE SEPARATE AND IDENTIFY ALL PARTS, MAKING SURE THAT YOU HAVE ALL OF THE PARTS LISTED.
2. TO AVOID ANY SCRATCH DURING ASSEMBLY, PLEASE ASSEMBLE ON A SOFT MAT OR SIMILAR.
3. PLEASE ASSEMBLE STEP BY STEP AND FOLLOW THE INSTRUCTIONS.
4. WASHERS MUST BE USED.
5. WHILE EACH SCREW AND NUT IS PROPERLY FASTENED, DO NOT OVER FASTEN IT.

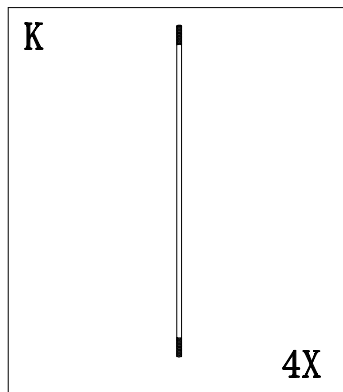
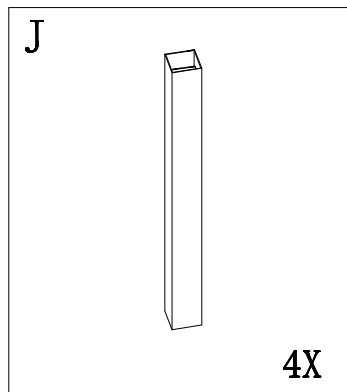
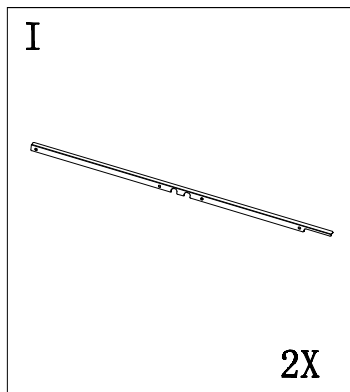
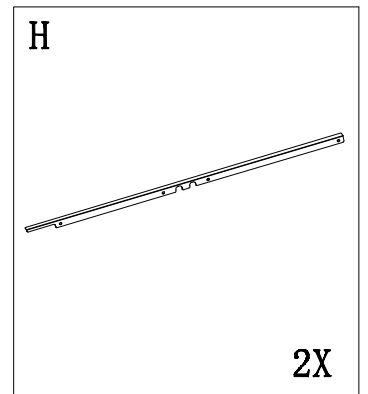
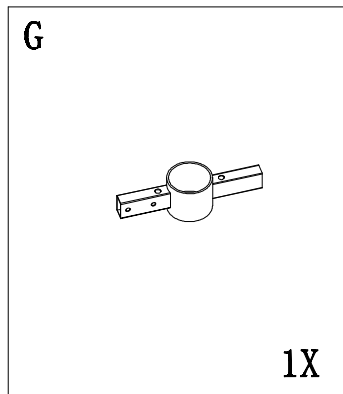
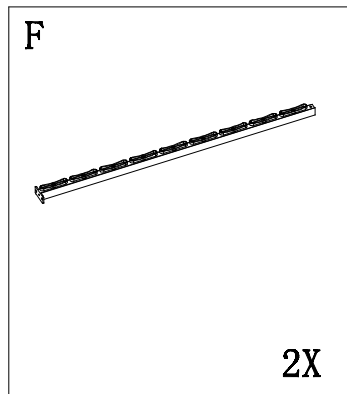
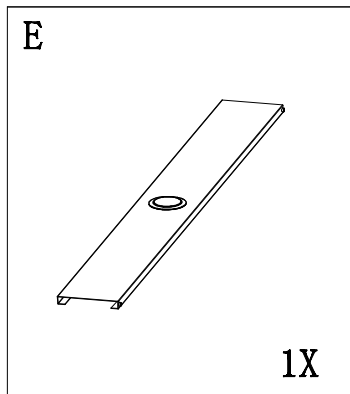
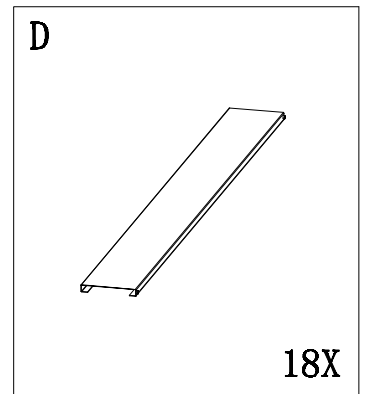
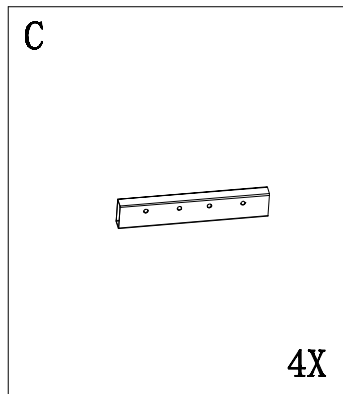
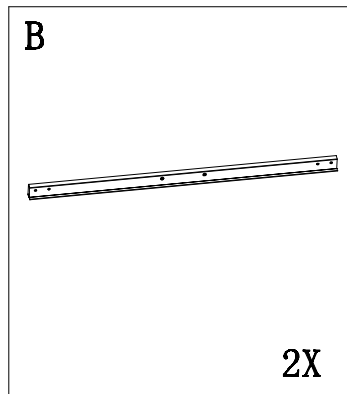
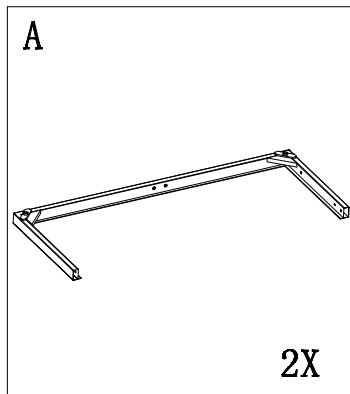

L

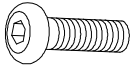

M6*15

32X

M

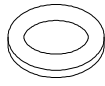

32X

N



St4. 2*40

2X

O

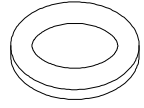

8X

P

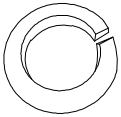

8X

Q

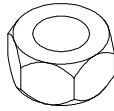

8X

R

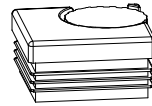

4X

S



S4

1X

T

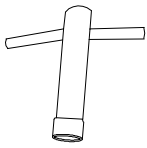

1X



B 2X

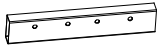

C 4X



L 4X



M 4X



S S4
1X

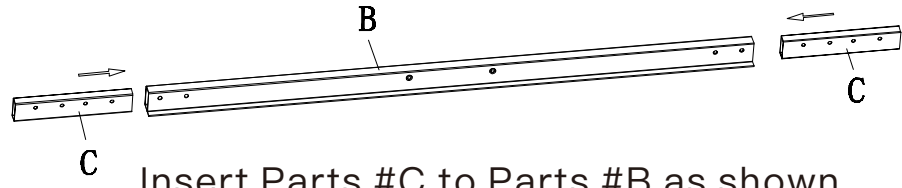

Insert Parts #C to Parts #B as shown.

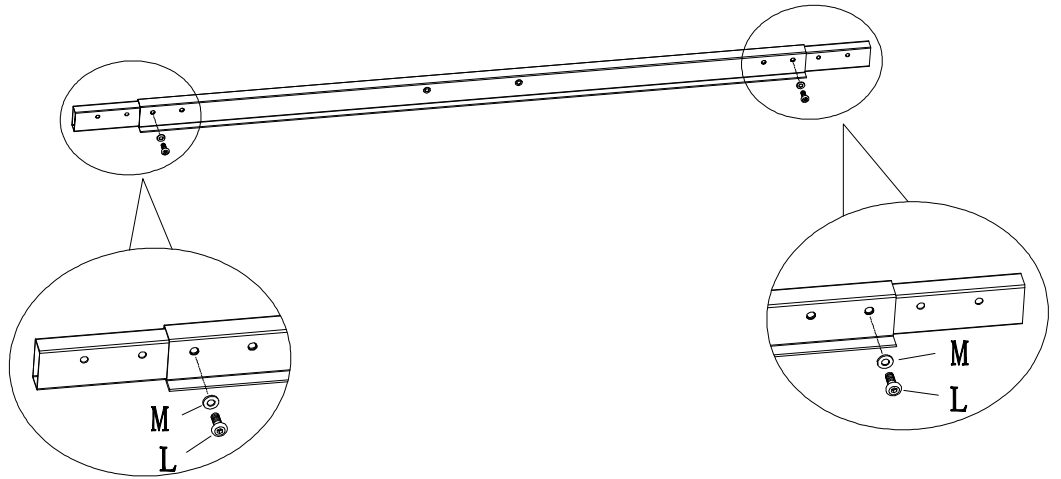

Attention: The installation hole position of the bolts #L and washers #M should be placed as shown.



A 2X



L 4X



M 4X



S S4
1X

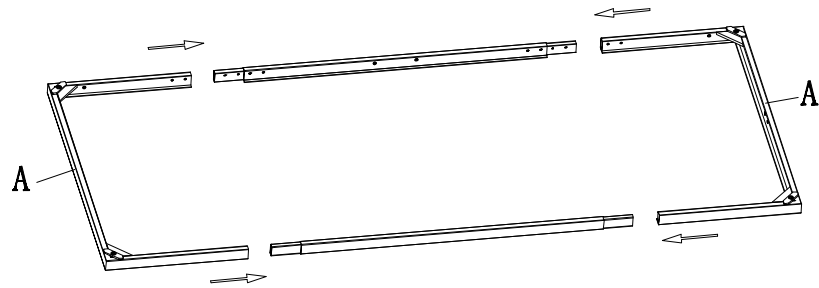

Insert #A into the #B in the previous step as shown.

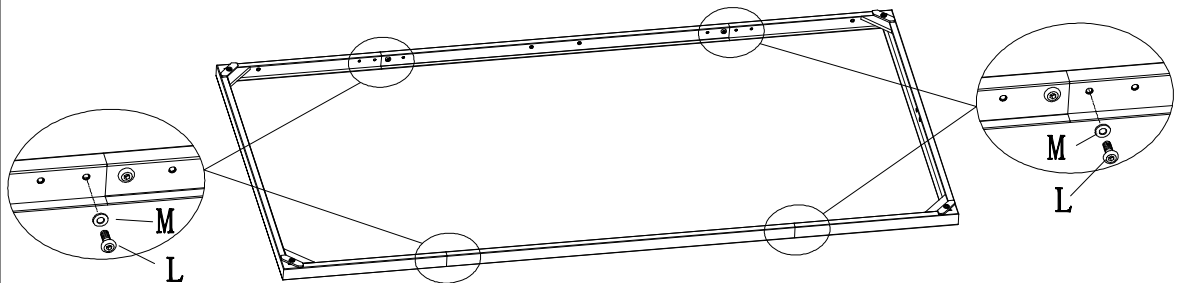

Attention: The installation hole position of the bolts #L and washers #M should be placed as shown.

1

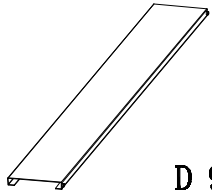

D 9X

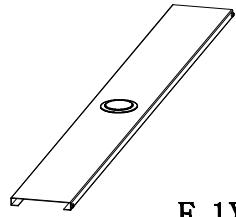

E 1X

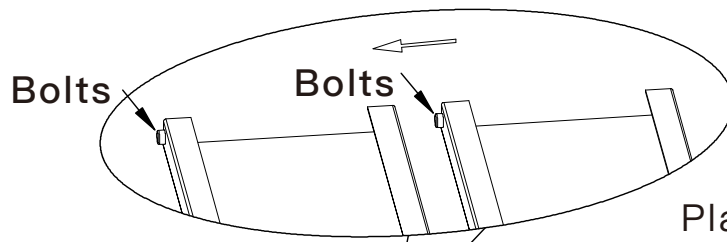

Bolts

Bolts

Place the tabletops #D in sequence from left to right as shown, and place #E in the middle.

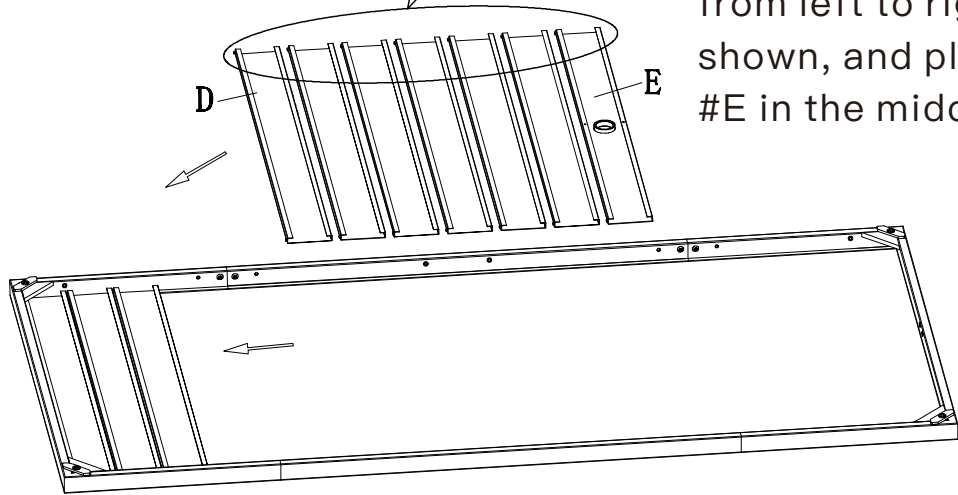

Note that the bolts on the sides of each tabletop panel should face the same direction.

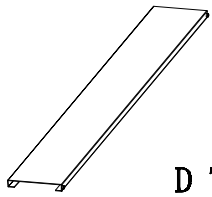

D 7X

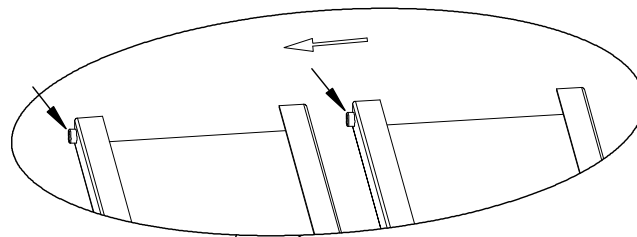

D

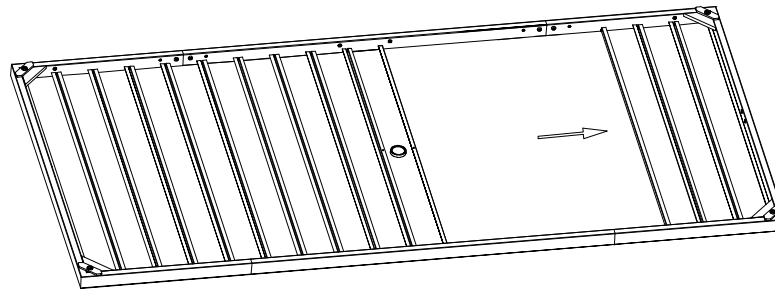

Do the tabletop panel installation for the right part the same as above.

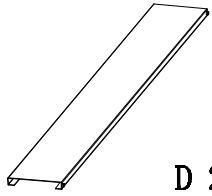

D 2X

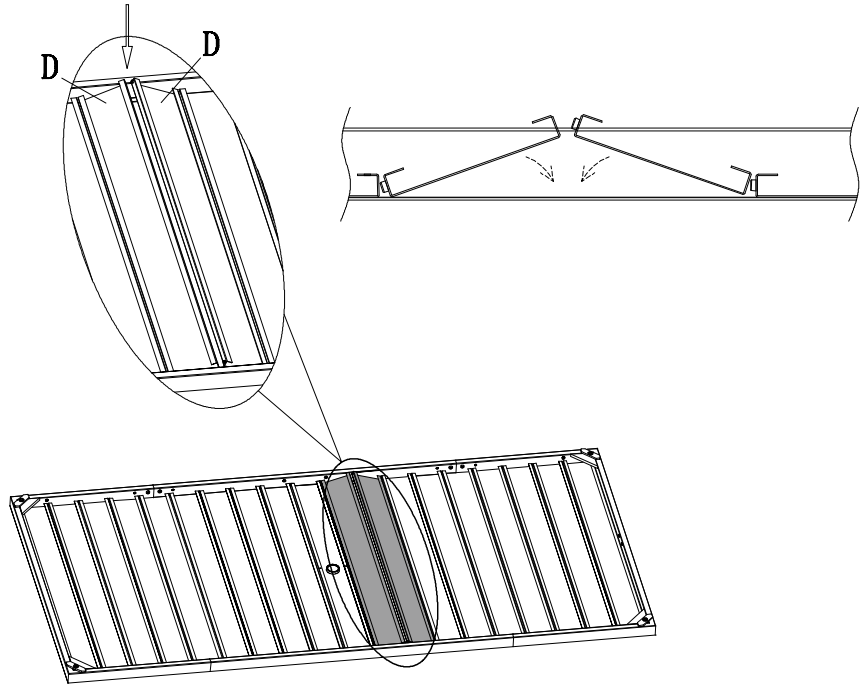

When there are the last two tabletops remaining, open them to the angle as shown for assembly.

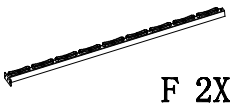

F 2X

Insert 2 Parts #F to Parts #G as shown.

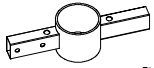

G 1X

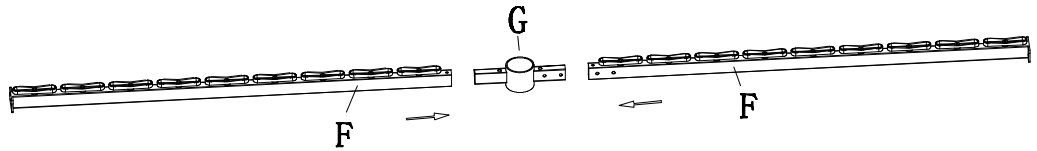

L 4X



M 4X



S 4
1X

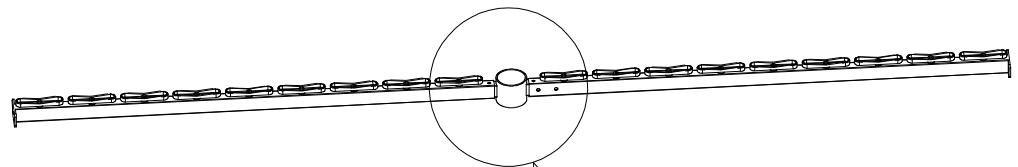

Secure the connecting rod with 4 bolts #L and 4 washers #M as shown.

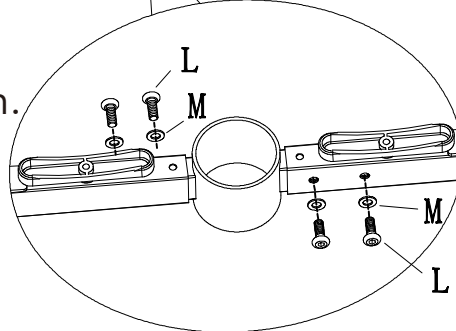

3

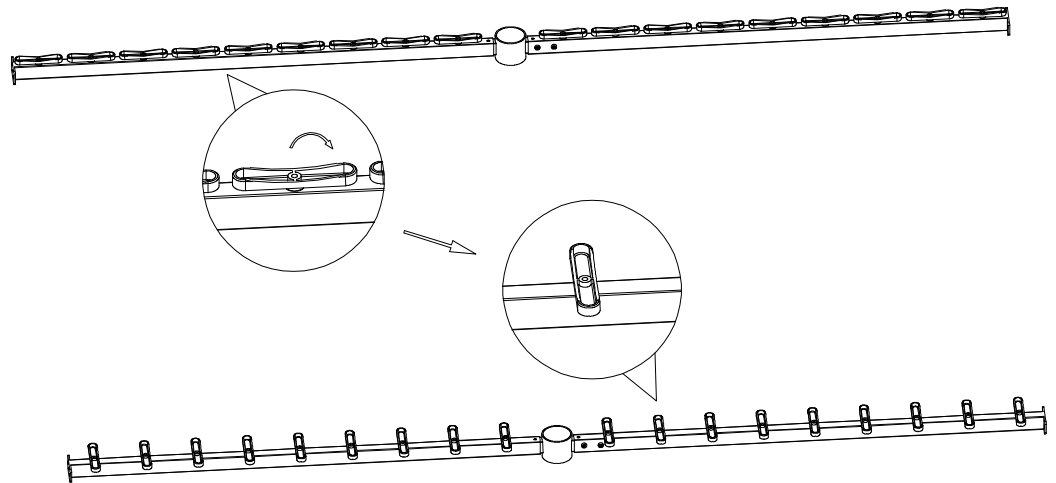

Rotate each plastic clip 90° perpendicular to the connecting rod as shown.

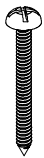

N 2X

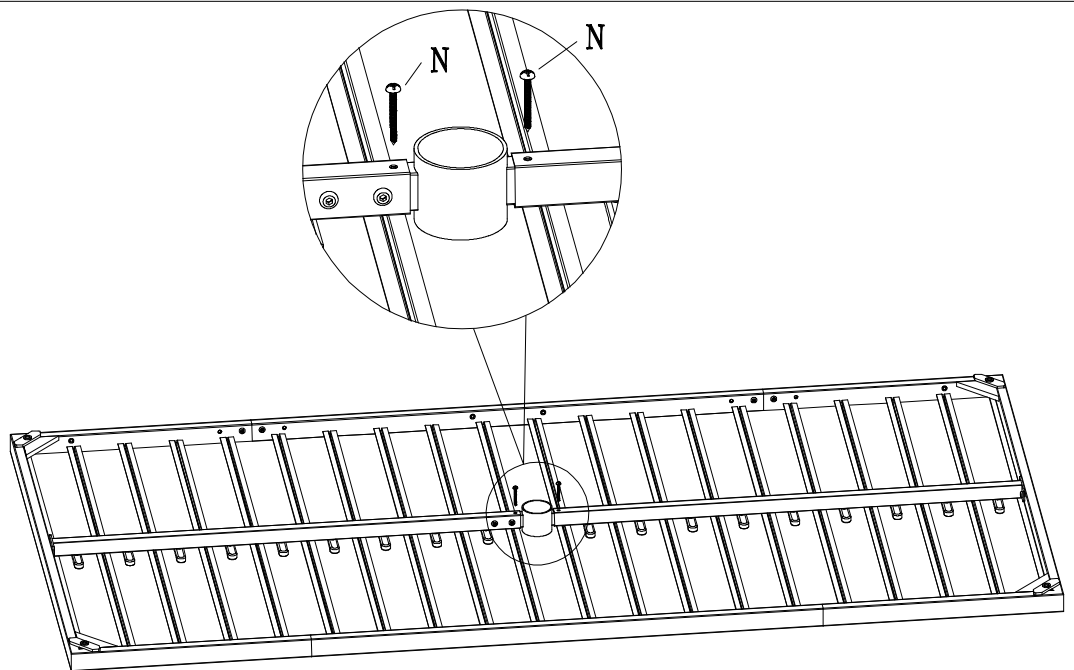

Place the connecting rod in the center of the tabletop, and tighten the 2 screws #N at the screw holes on both sides.

4



L 4X



M 4X



S S4
1X

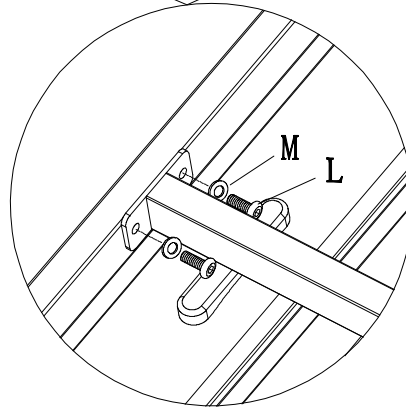
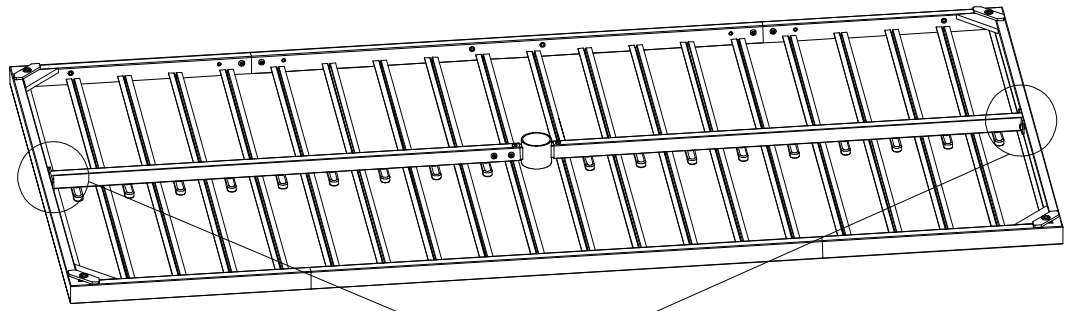



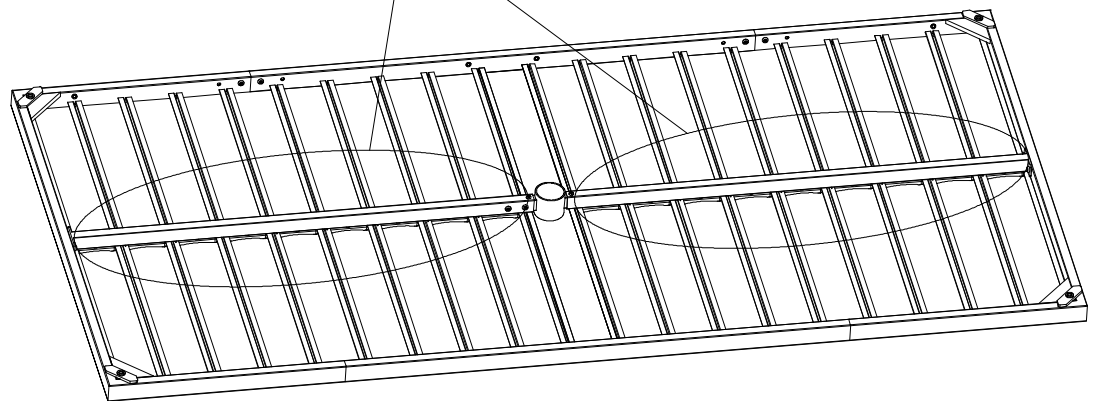
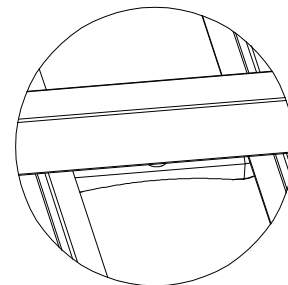
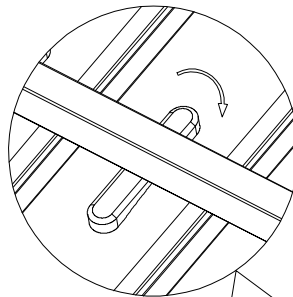

Assemble tabletop to the connecting rod with washers #M and bolts #L. After all bolts are assembled in place, tighten them together as shown.

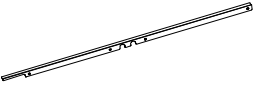
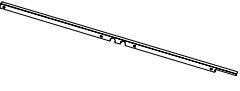

Rotate each plastic clip for 90° to reset as shown.



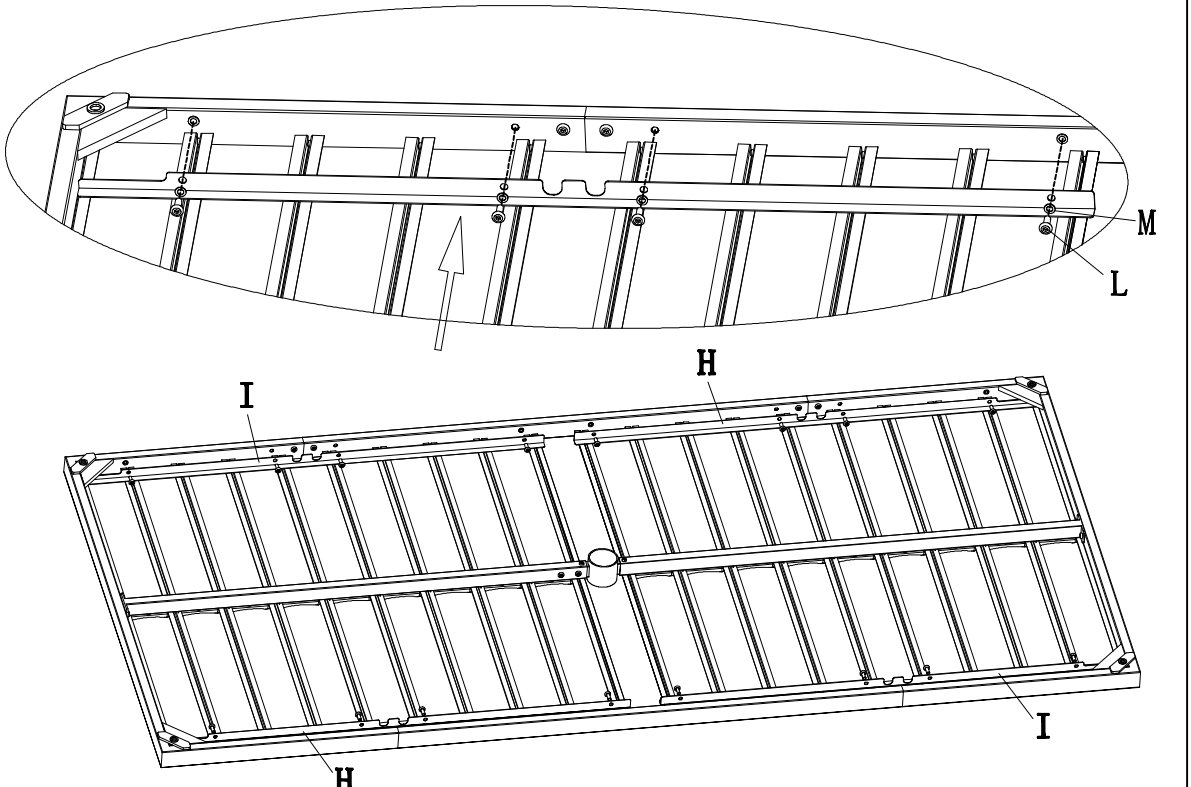

5

-  H 2X
-  I 2X
-  L 16X
-  M 16X
-  S S4
1X

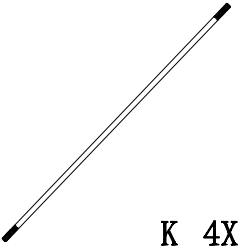

(1) Place fixed iron pieces #H and #I diagonally as shown, noting that the narrower side inserts outward.

(2) Insert bolts #L and washers #M into the hole positions by the tool #S as shown. After all bolts are assembled in place, tighten them together.

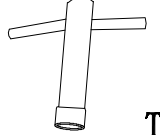
-  K 4X
-  O 4X
-  P 4X
-  Q 4X
-  T 1X

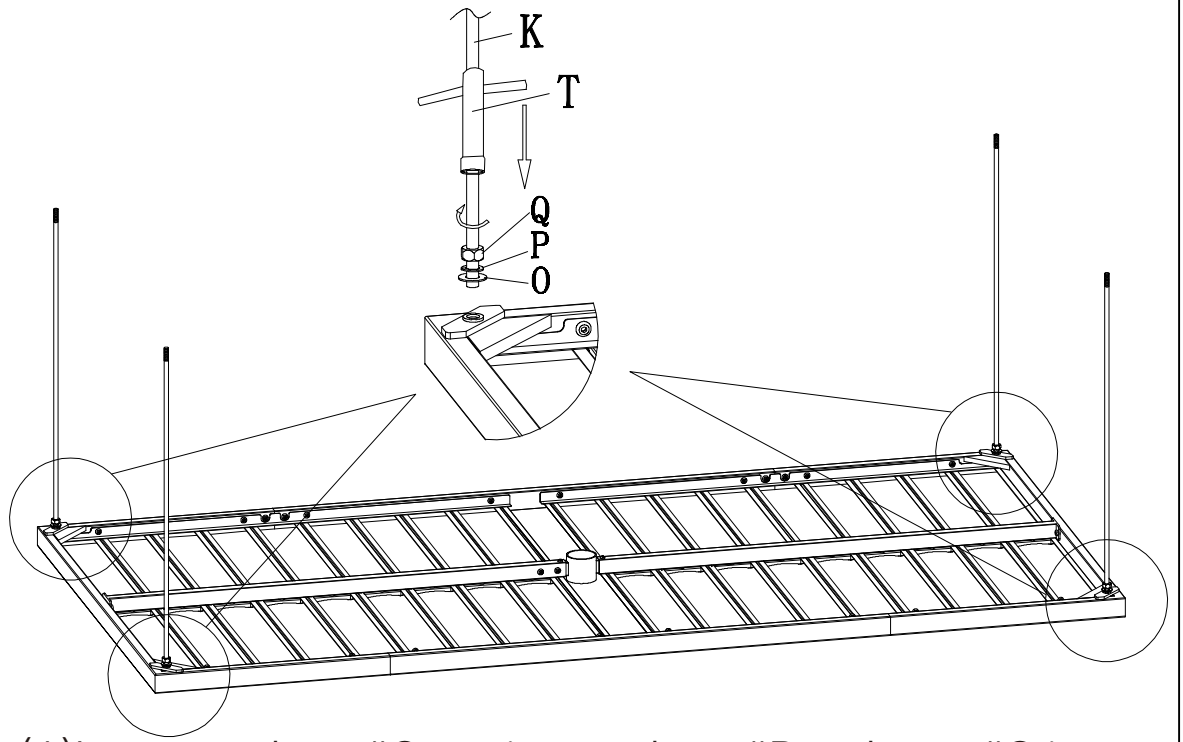

(1) Insert washers #O, spring washers #P and nuts #Q into parts #K as shown.

(2) Align #K with the hole position, twist it by hand until it cannot be turned. And tighten parts #K with wrench #T.

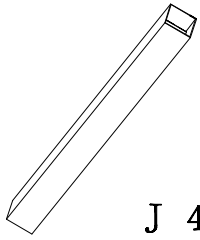

J 4X



O 4X



P 4X



Q 4X

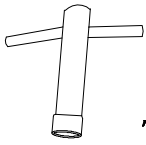

T 1X

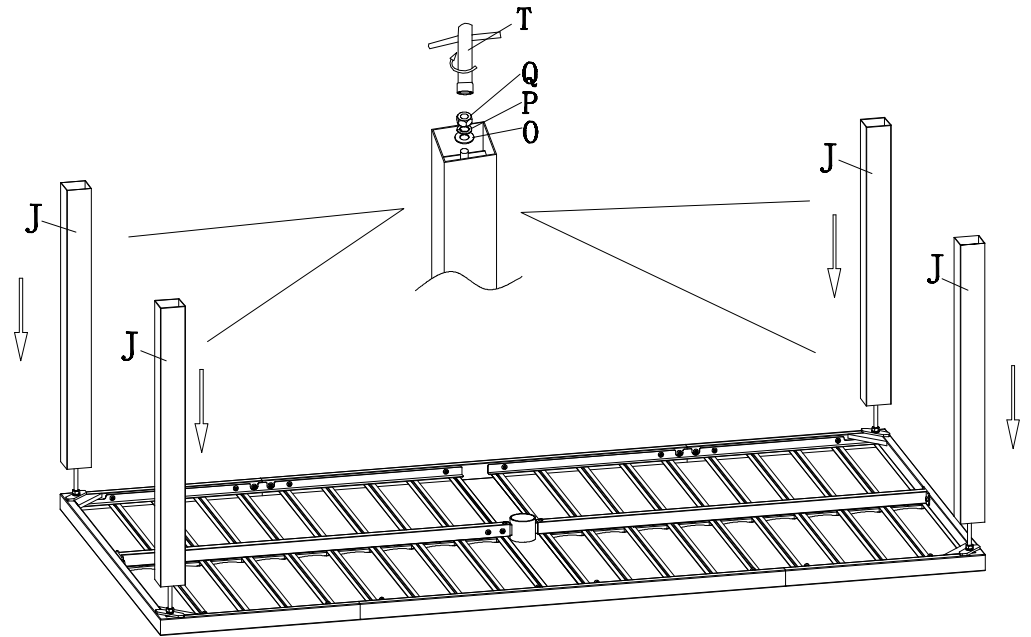

- (1) Set table legs #J into parts #K, then install the washers #O, spring washers #P and nuts #Q on #K.
- (2) Tighten them with wrench #T. (The remaining legs #L follows the same steps as above.)

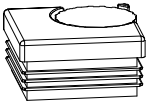

R 4X

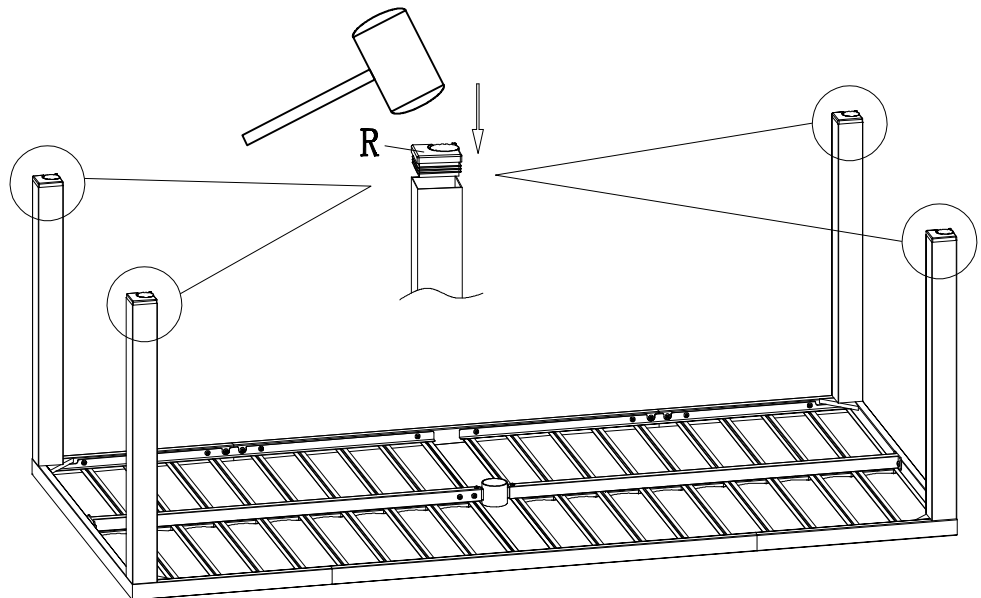

Put adjustable foot pads #R into #J and press it with a hammer

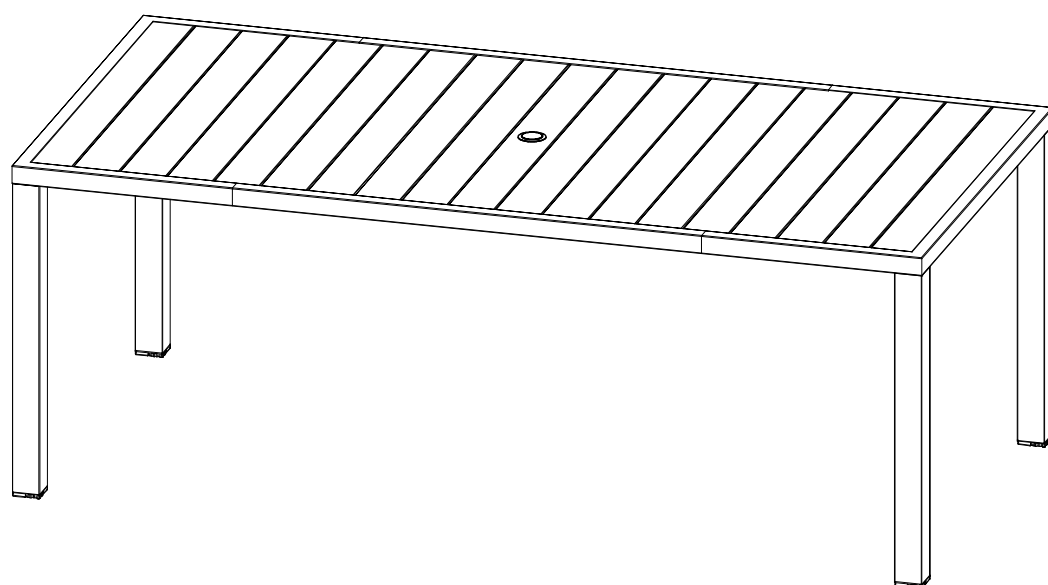



Thanks for your purchase.

At domi outdoor living, we believe in our products.

That's why we provide a 12-month warranty and

friendly, easy-to-reach after-sales service. So if you

have any questions about our product and assembly-

,please feel free to contact us. We will be here for you.

Support:  

After-sales contact email:

service@domioutdoorliving.com

Business cooperation contact email:

marketing@domioutdoorliving.com

Please tell us your order ID when contact.

Attach photos of damaged part for instant reply.