

Installation & Assembly

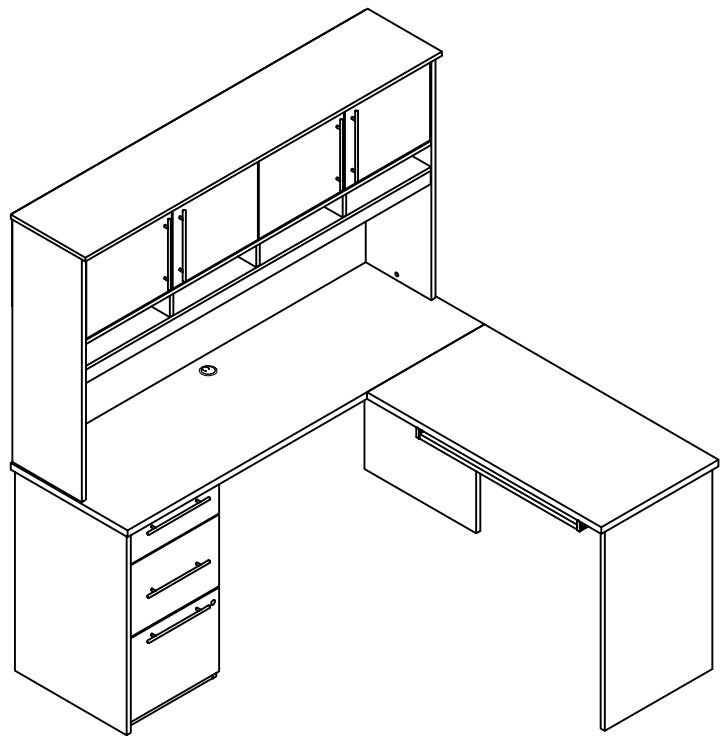
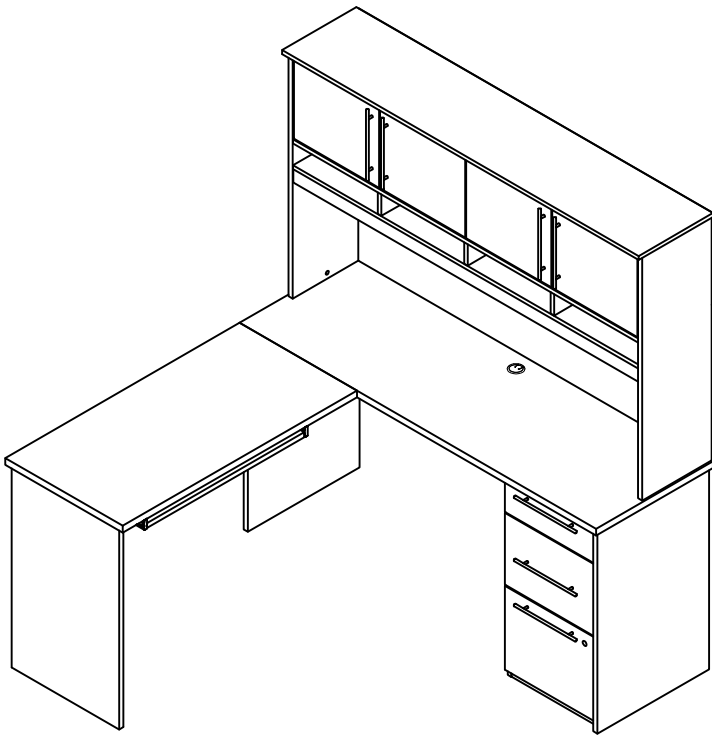

Thank you for choosing. Your total satisfaction is our #1 priority.

Customer Service and warranty information

Please have your assembly instruction manual on hand when you call. are warranted to the original purchaser against defects in material or workmanship in the furniture. Defects as mentioned in this warranty refer to any imperfections which may impair the use of the product. Our warranty is expressly limited to the replacement of furniture parts and components for ten years following the date of purchase. will replace any part that is defective. This warranty applies under conditions of normal use. Our furniture products are not intended for outdoor use. The warranty does not cover defects caused by improper assembly or disassembly, defects occurring after purchase due to product modifications, intentional damage, accident, misuse, exposure to the elements and labor or assembly costs. reserves the right to request proof of purchase to document a warranty claim. In no event shall be liable for incidental or consequent damages resulting from the misuse of the product. This warranty is not transferable and is valid only in Canada and the United States excluding Alaska, Hawaii and Puerto Rico.



MERCI D'AVOIR CHOISI. VOUS SATISFAIRE EST NOTRE PRIORITÉ.

Service à la clientèle et informations relatives à la garantie

Veillez avoir en main le manuel d'instructions lors de votre appel. La garantie des est valide, pour l'acheteur original, en cas de défaut de matériel ou de fabrication. Les défauts couverts par cette garantie incluent toutes les imperfections qui ont pour conséquence une utilisation non appropriée du produit. Notre garantie est expressément limitée au remplacement des composants et des éléments de meubles pour une durée de dix ans suivant la date de l'achat. s'engage à remplacer tout élément défectueux. Cette garantie s'inscrit dans le cadre d'une utilisation du produit dans des conditions normales. Nos meubles ne sont pas destinés à être utilisés à l'extérieur. La garantie ne couvre pas les défauts générés par un assemblage ou un démontage non conforme, les défauts apparus suite à des modifications apportées au produit, à des dommages intentionnels, à un accident, une mauvaise utilisation, l'utilisation à l'extérieur, ni les coûts de main d'œuvre ou d'assemblage. se réserve le droit d'exiger une preuve d'achat afin de documenter la réclamation. La société ne pourra être tenue, en aucun cas, responsable de dommages indirects ou consécutifs, suite à une mauvaise utilisation du produit. Cette garantie ne peut être transférée et est valide au Canada et aux États-Unis sauf Hawaï, Puerto Rico et Alaska.

Gracias por elegir un.
Su entera satisfacción es nuestra prioridad N°1.

Servicio de atención al cliente e información sobre la garantía

Cuando llame, tenga a mano su manual de instrucciones de montaje. Los están garantizados por el comprador original contra defectos en el material o en la confección del mueble. Los defectos, tal como se describen en esta garantía incluyen toda imperfección que pueda impedir el uso del producto. Nuestra garantía se limita expresamente al reemplazo de las partes y componentes del mueble defectuosos por diez años a partir de la fecha de compra. reemplazará cualquier pieza defectuosa. Esta garantía se aplica según las condiciones de uso normal. Nuestros productos no están diseñados para ser utilizados al aire libre. La garantía no cubre defectos provocados por ensamblaje o desensamblaje incorrectos, defectos ocurridos luego de la compra por la modificación del mueble, daños intencionales, accidentes, uso incorrecto, exposición a los agentes naturales ni costos derivados de la fabricación o ensamblaje. se reserva el derecho de solicitar una factura de compra para poder extender un reclamo de garantía. Bajo ninguna circunstancia será responsable de los daños accidentales o consecuentes que pudieran resultar del uso incorrecto del producto. Esta garantía es intransferible y se aplica solamente a Canadá y los Estados Unidos.

Get Ready to Assemble

For best results, keep these tips in mind:

- ① We know you want to finish this assembly as quickly as possible, but trust us: you'll have a better experience if you take it one step at a time.
- ② Give yourself some room to work near where you want the fully assembled product.
- ③ If your floor isn't carpeted, assemble this product on the empty carton to avoid scratching.
- ④ Do you have a friend who owes you a favor? Some steps may go a little easier with a second set of hands.

DOs

- ✔ Wear safety glasses at all times during assembly
- ✔ Carefully follow the instructions in this guide and complete all steps in order
- ✔ Give us a call if you're having trouble with a particularly tricky step

DON'Ts

- ✘ Never move your furniture with items inside or resting on the surface
- ✘ Do not attempt to use this product before all steps have been completed

IMPORTANT NOTICE / NOTE IMPORTANTE / NOTA IMPORTANTE



two people are required to assemble and move this model.
deux personnes sont requises pour assembler et déplacer ce modèle.
se necesitan dos personas para ensamblar y desplazar este mueble.



Use electric tools with caution.
Use herramientas eléctricas con precaución.
Utilisez les outils électriques avec prudence.

tools required outils requis herramientas necesarias

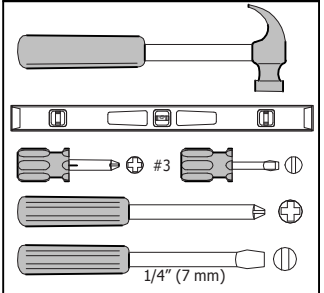

IMPORTANT NOTICE / NOTE IMPORTANTE / NOTA IMPORTANTE

Group together all the hardware required for each step as the construction of your piece of furniture is progressing.

Regroupez toutes les quincailleries requises pour chaque étape de façon à vous assurer de tout installer au bon moment.

Reúna todas las quincallas necesarias para cada una de las etapas de montaje, para asegurar una correcta instalación en el momento adecuado.

IMPORTANT SAFETY INFORMATION



PLEASE READ WARNINGS

Improper use can cause safety hazards, or damage to your furniture and household items.

Warning	Do	Don't	Why it's important
Serious injury may occur.	<ul style="list-style-type: none">Assemble following all instructions using all indicated parts and hardware provided.	<ul style="list-style-type: none">Do not move unit when loaded.Do not load with a television or other heavy equipment.Do not exceed the maximum load limits stated in the instructions.	Improper assembly, use or loading can lead to product instability, tip-over or collapse.

Advertencia	Hacer	No	Por qué es importante
Se pueden producir lesiones graves.	<ul style="list-style-type: none">Ensamble siguiendo todas las instrucciones utilizando todas las piezas y ferretería indicados provistos.	<ul style="list-style-type: none">No mueva la unidad cuando esté cargada.No cargue con un televisor u otro equipo pesado.No exceda los límites máximos de carga establecidos en las instrucciones.	El ensamblaje, uso o carga inadecuados pueden provocar inestabilidad del producto, vuelco o colapso.

Avertissement	Faire	Ne le fais pas	Pourquoi c'est important
Des blessures graves peuvent survenir.	<ul style="list-style-type: none">Assemblez en suivant toutes les instructions en utilisant toutes les pièces et le matériel indiqués fournis.	<ul style="list-style-type: none">Ne déplacez pas l'unité lorsqu'elle est chargée.Ne chargez pas avec un téléviseur ou un autre équipement lourd.Ne dépassez pas les limites de charge maximale indiquées dans les instructions.	Un assemblage, une utilisation ou un chargement incorrects peuvent entraîner une instabilité du produit, un renversement ou un effondrement.

IMPORTANT SAFETY INFORMATION



PLEASE READ WARNINGS

Improper use can cause safety hazards, or damage to your furniture and household items.

Warning	Do	Don't	Why it's important
Serious injury may occur.	<ul style="list-style-type: none">Assemble following all instructions using all indicated parts and hardware provided.Attach hutch as described in the instructions.Verify furniture is stable on it's own.	<ul style="list-style-type: none">Do not move unit when loaded.Do not load with a television or other heavy equipment.Do not exceed the maximum load limits stated in the instructions.Do not allow children to climb, or hang on furniture.	Improper assembly, use or loading can lead to product instability, tip-over or collapse.

Advertencia	Hacer	No	Por qué es importante
Se pueden producir lesiones graves.	<ul style="list-style-type: none">Ensamble siguiendo todas las instrucciones utilizando todas las piezas y ferretería indicados provistos.Coloque la conejera como se describe en las instrucciones.Verifique que los muebles sean estables por sí mismos.	<ul style="list-style-type: none">No mueva la unidad cuando esté cargada.No cargue con un televisor u otro equipo pesado.No exceda los límites máximos de carga establecidos en las instrucciones.No permita que los niños se paren, trepen o cuelguen de muebles.	El ensamblaje, uso o carga inadecuados pueden provocar inestabilidad del producto, vuelco o colapso.



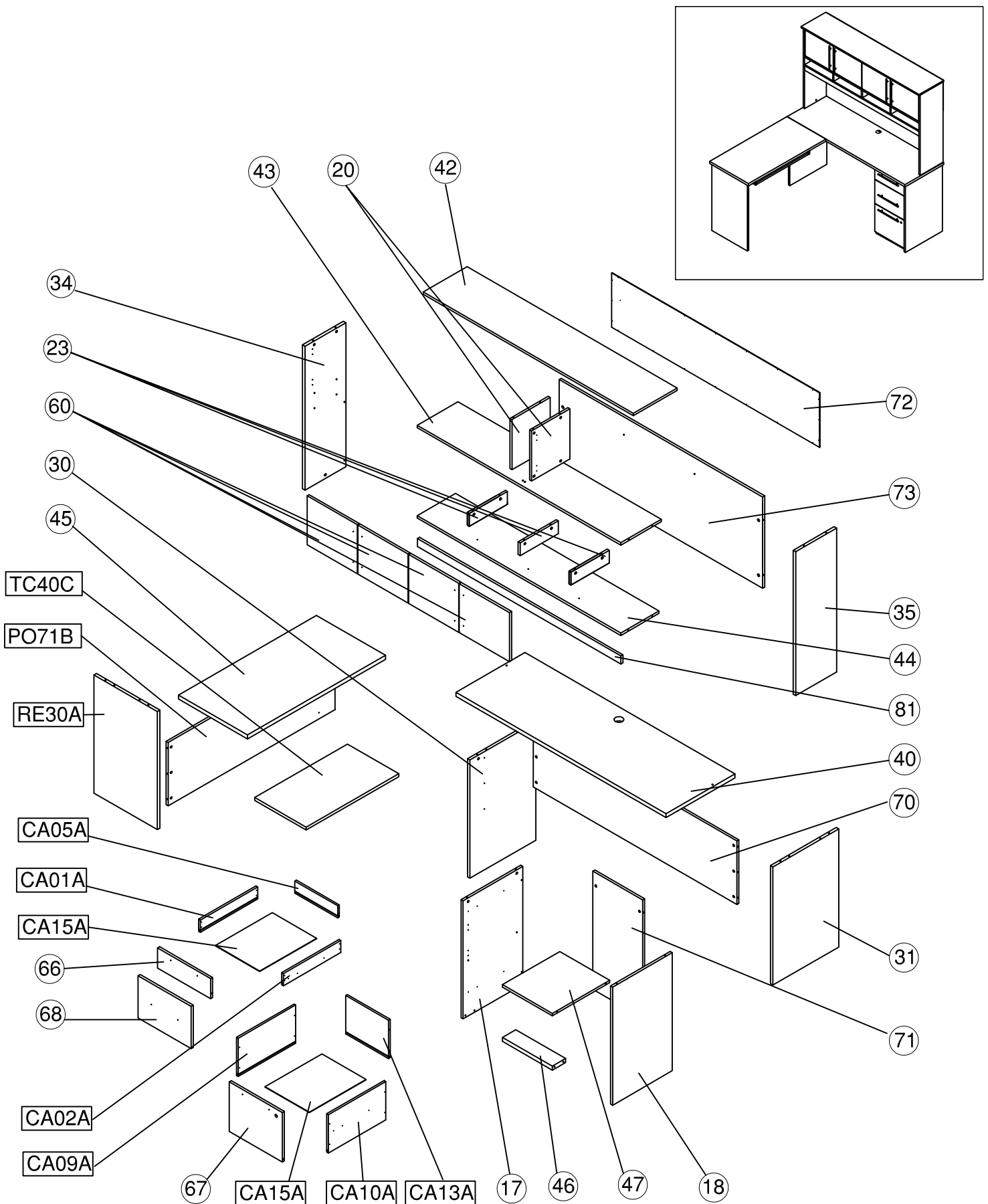

Avertissement	Faire	Ne le fais pas	Pourquoi c'est important
Des blessures graves peuvent survenir.	<ul style="list-style-type: none">Assemblez en suivant toutes les instructions en utilisant toutes les pièces et le matériel indiqués fournis.Fixez la huche comme décrit dans les instructions.Vérifiez que les meubles sont stables par eux-mêmes.	<ul style="list-style-type: none">Ne déplacez pas l'unité lorsqu'elle est chargée.Ne chargez pas avec un téléviseur ou un autre équipement lourd.Ne dépassez pas les limites de charge maximale indiquées dans les instructions.Ne laissez pas les enfants grimper ou s'accrocher aux meubles.	Un assemblage, une utilisation ou un chargement incorrects peuvent entraîner une instabilité du produit, un renversement ou un effondrement.

Get to know your Boards

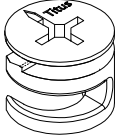
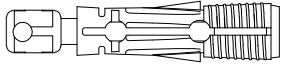
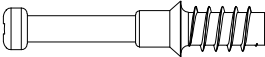
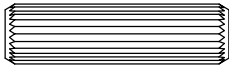
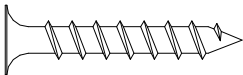
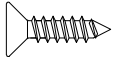
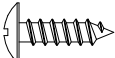
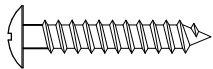

Get to know your Fasteners

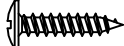
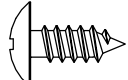
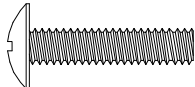
Fasteners are shown actual size.

H181468	 KD Cam	[64]	H166336	 Quick Connect	[28]
H180604	 KD Bolt	[36]	H38169	 Wood Dowel 8 x 30mm	[10]
H26053	 #10 x 1-1/4"	[8]	H167433	 #6x9/16"	[20]
H101725	 #6 x 1/2"	[45]	H150019	 #8 x 1"	[14]
H186067	 #3 x 3/4" NICKEL	[20]	H153243	 #5x9/16"	[6]
H35251	 #10 x 1/2"	[18]	H160460	 M4 x 22MM	[14]
H175158	 #12 x 9/16"	[4]			

Get to know your Hardware

Hardware not to scale.

H166299

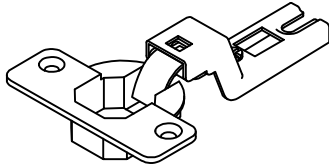

[4]

Hinge

H166306

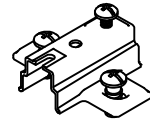

[4]

Mounting Plate

H201026

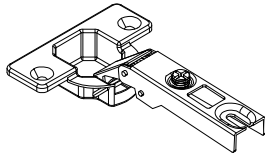

[6]

Hinge

H201027

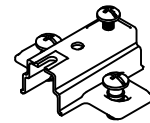

[6]

Mounting Plate

H39922

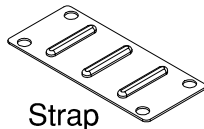

[2]

Strap

H194566

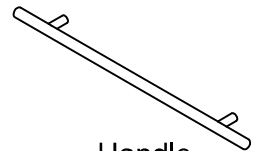

[7]

Handle

H85966

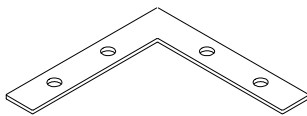

[2]

L" Bracket

H180871

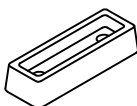

[2]

Door Stopper

H149989



[1]

Bumper

Get to know your Hardware

Hardware not to scale.

H100444

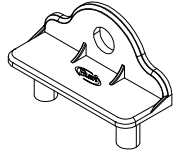

[2]

Drawer Bracket

H100446

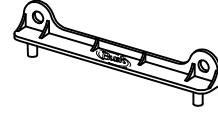

[2]

Drawer Bracket

H199615

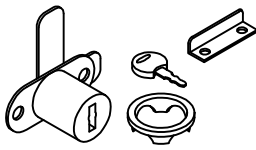

[1]

Lock Kit

H137197

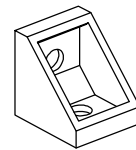

[5]

Plastic Bracket

H195624

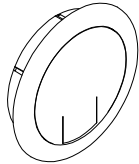

[1]

Grommet

H170595



[43]

Cover Cap

H170594

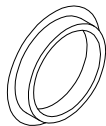

[1]

Cover Cap 15mm

H182573



[7]

Cover Cap 5mm

Get to know your Hardware

Hardware not to scale.

H200972

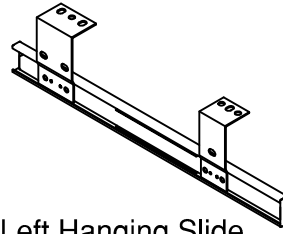

Left Hanging Slide

[1]

H200973

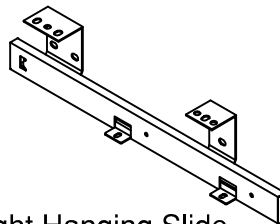

Right Hanging Slide

[1]

H167909

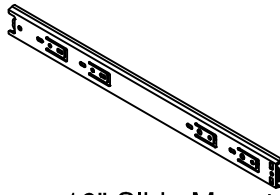

16" Slide Mount

[4]

H162488



File Extrusion
15-3/4" (399mm)

[2]

H94928

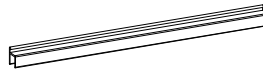

File Extrusion
12" (304mm)

[1]

H201025

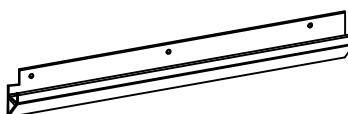

Front File Extrusion
12" (304mm)

[1]

STEP 1

Prepare Drawer Front

H35251

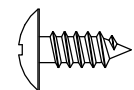

#10 x 1/2"

[4]

H100446

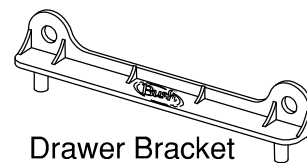

Drawer Bracket

[2]

H101725

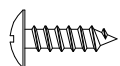

#6 x 1/2"

[3]

H201025

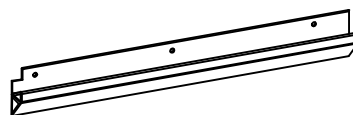

Front File Extrusion
12" (304mm)

[1]

H199615

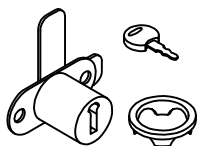

Lock Kit

[1]

H167433

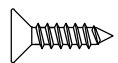

#6x9/16"

[2]

H35251

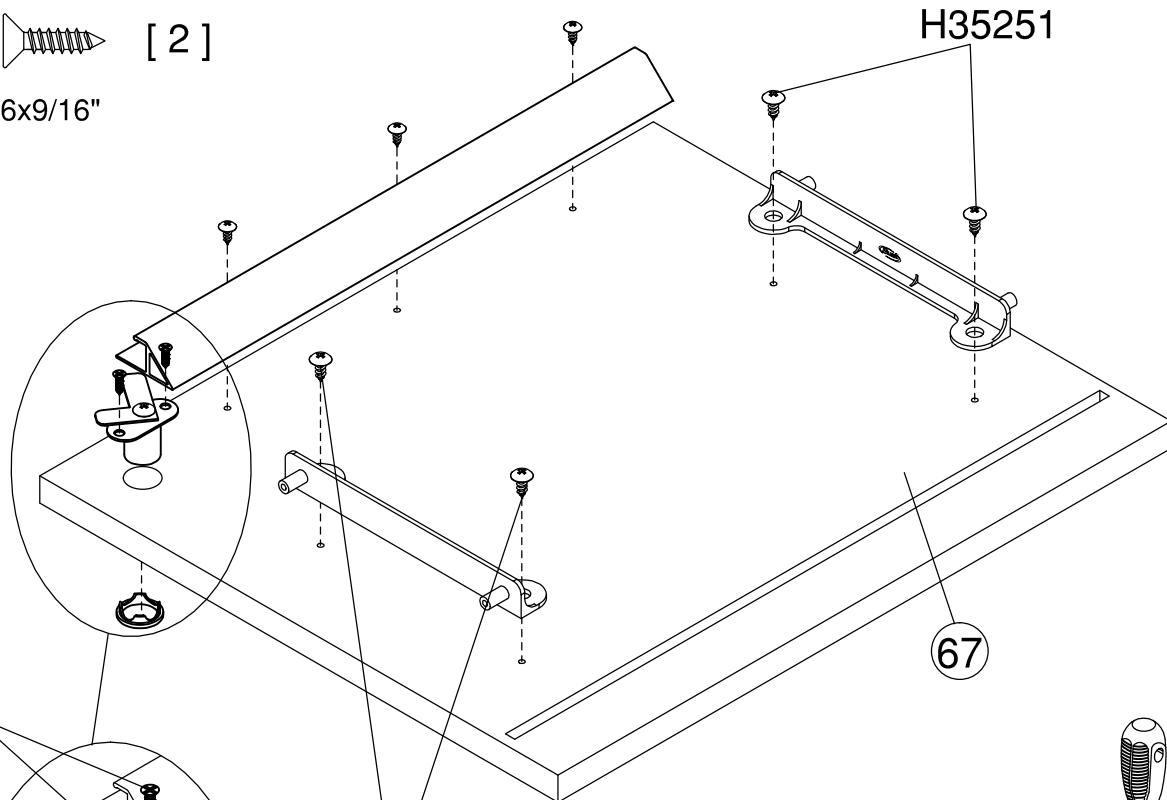

H167433

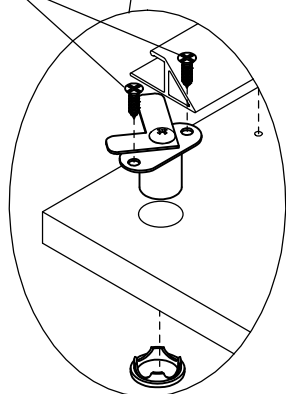

H35251

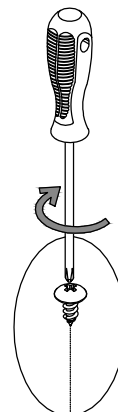

STEP 2

Assemble Drawer

H101725  [4]
#6 x 1/2"

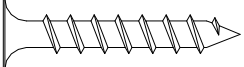
H26053  [4]
#10 x 1-1/4"

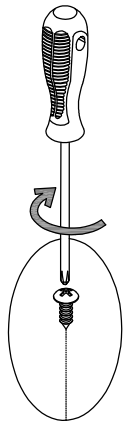
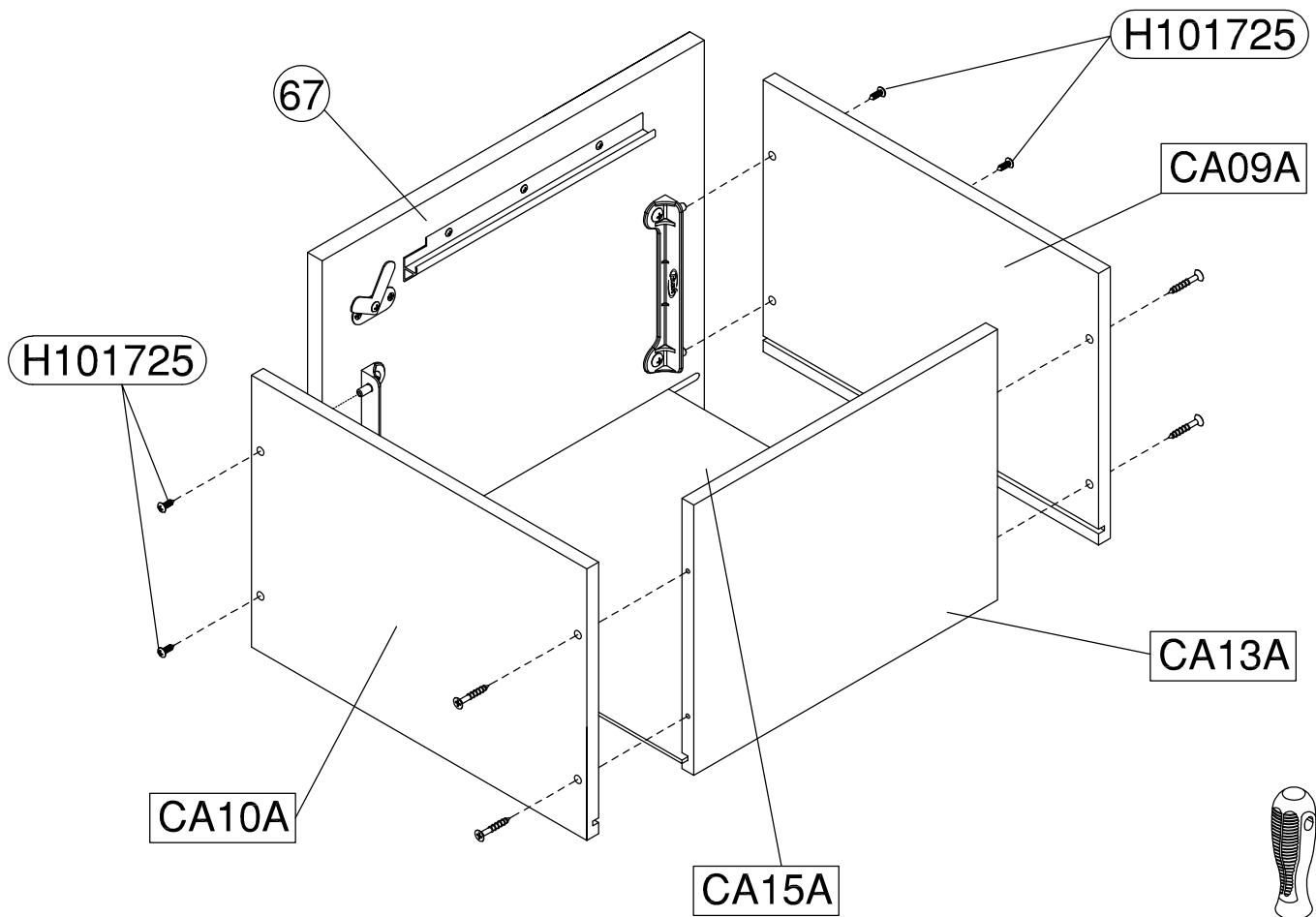

STEP 3

Separate Slides

**Slides Must Be Separated Before Assembly.
After Separated, Set Aside Until Needed for Assembly.**

Las diapositivas deben separarse antes del montaje.
Después de la separación, déjelo a un lado hasta que sea necesario.

Les glissières doivent être séparées avant l'assemblage.
Après la séparation, mettez de côté jusqu'au moment de l'assemblage.

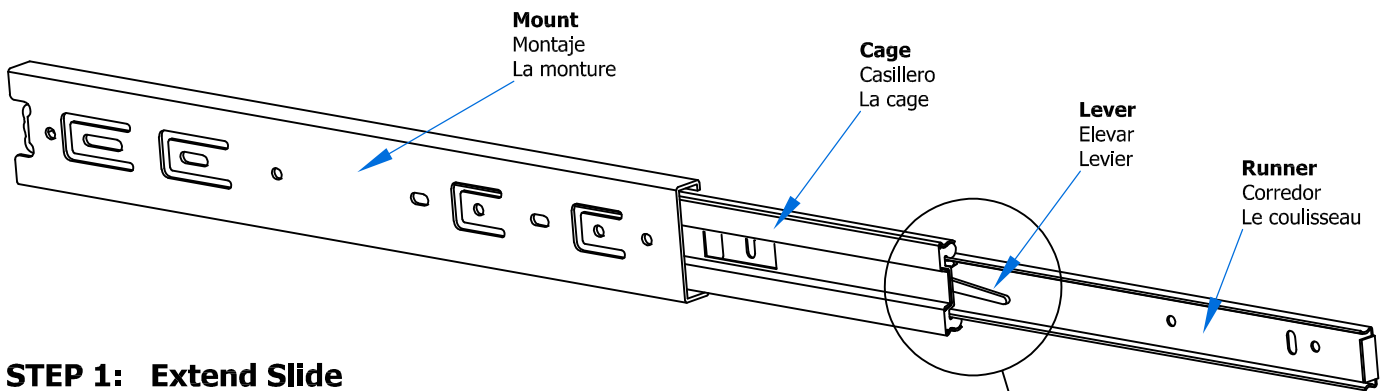

STEP 1: Extend Slide
Extender la diapositiva
Extendre la diapositive

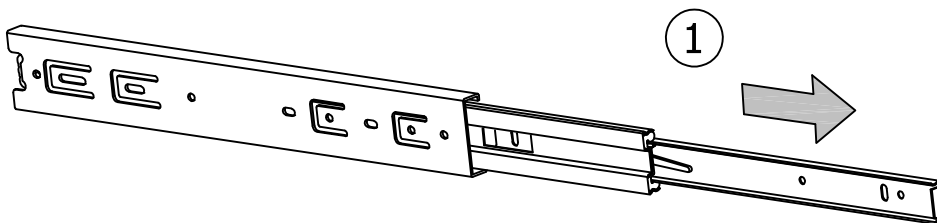

STEP 2: Push Lever UP
Empujar hacia arriba
Lever le levier

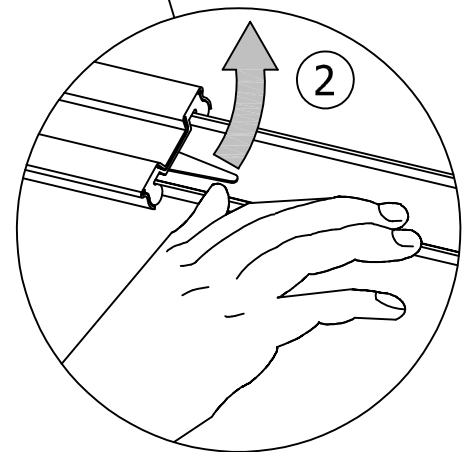

STEP 3: Remove Runner
Quitar el corredor
Enlever le coureur

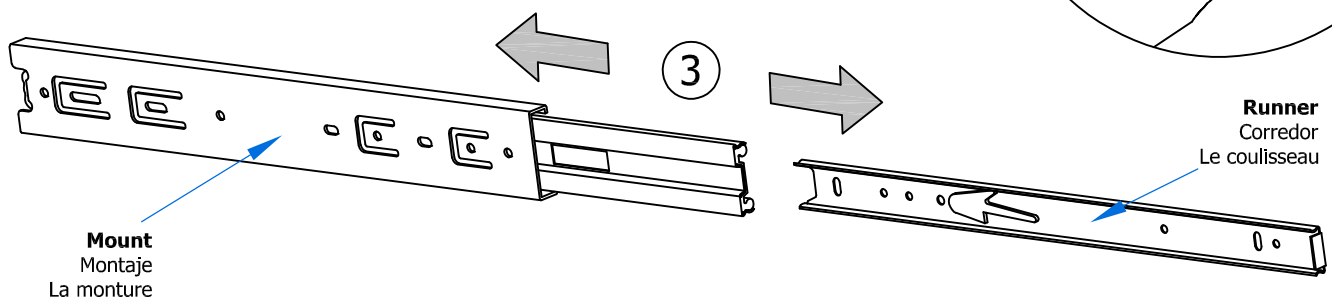

STEP 4

Install Slide Runners

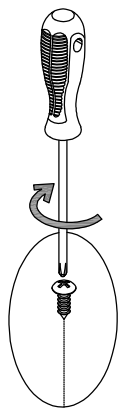
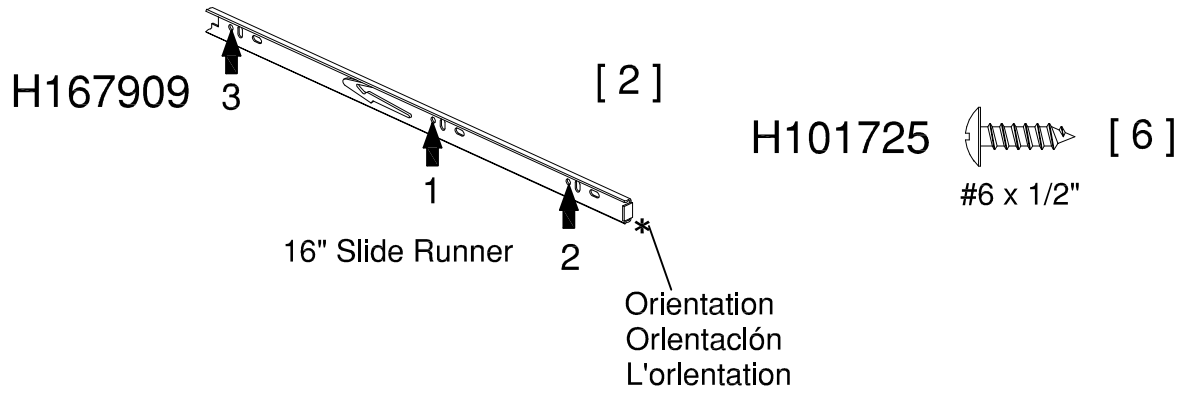

Orientation
Orientación
L'orientation

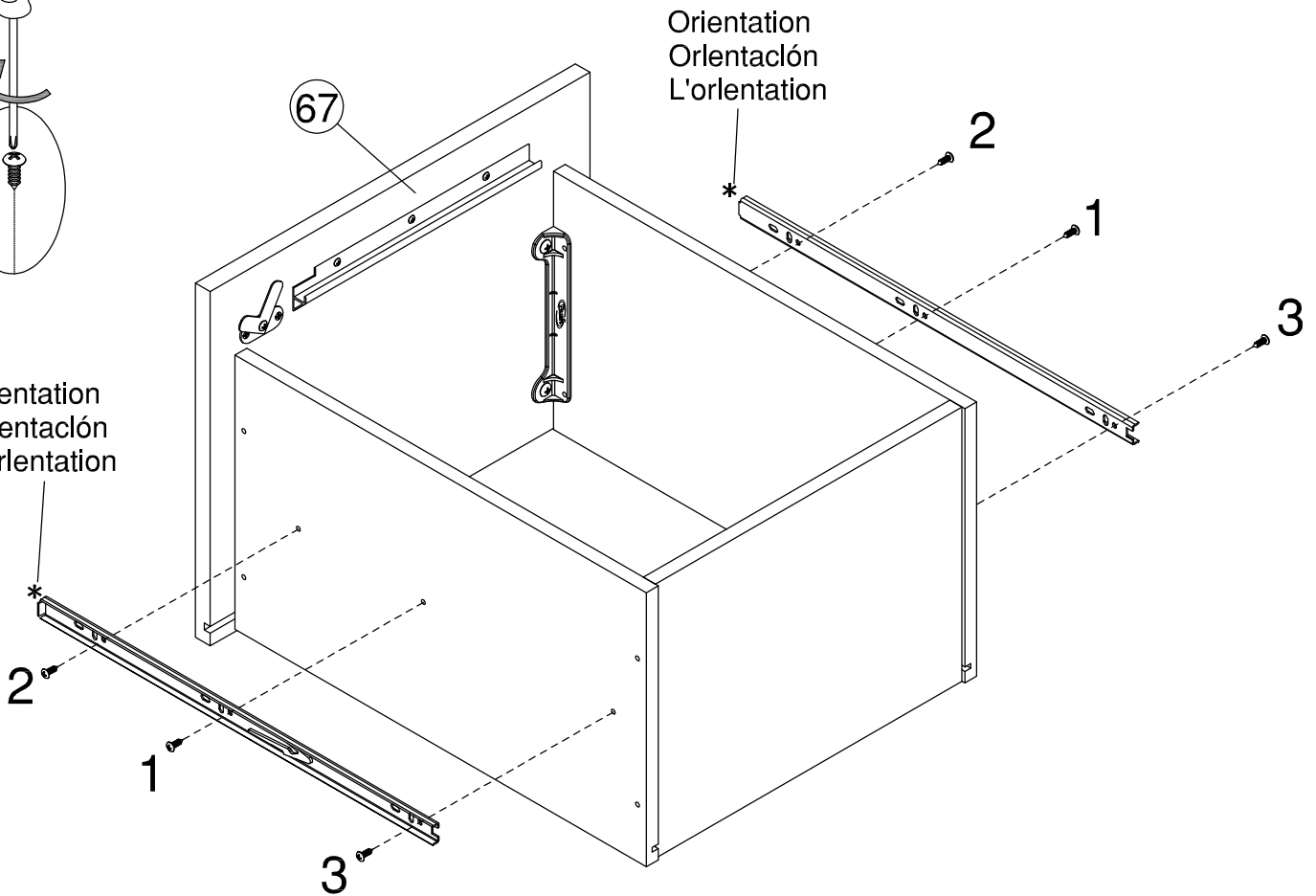

STEP 5

Install Hardware

H162488 [2]
File Extrusion
(399mm)

H94928 [1]
File Extrusion
(304mm)

H194566 [1]
Handle

H160460 [2]
M4 x 22MM

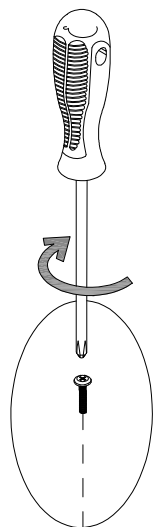
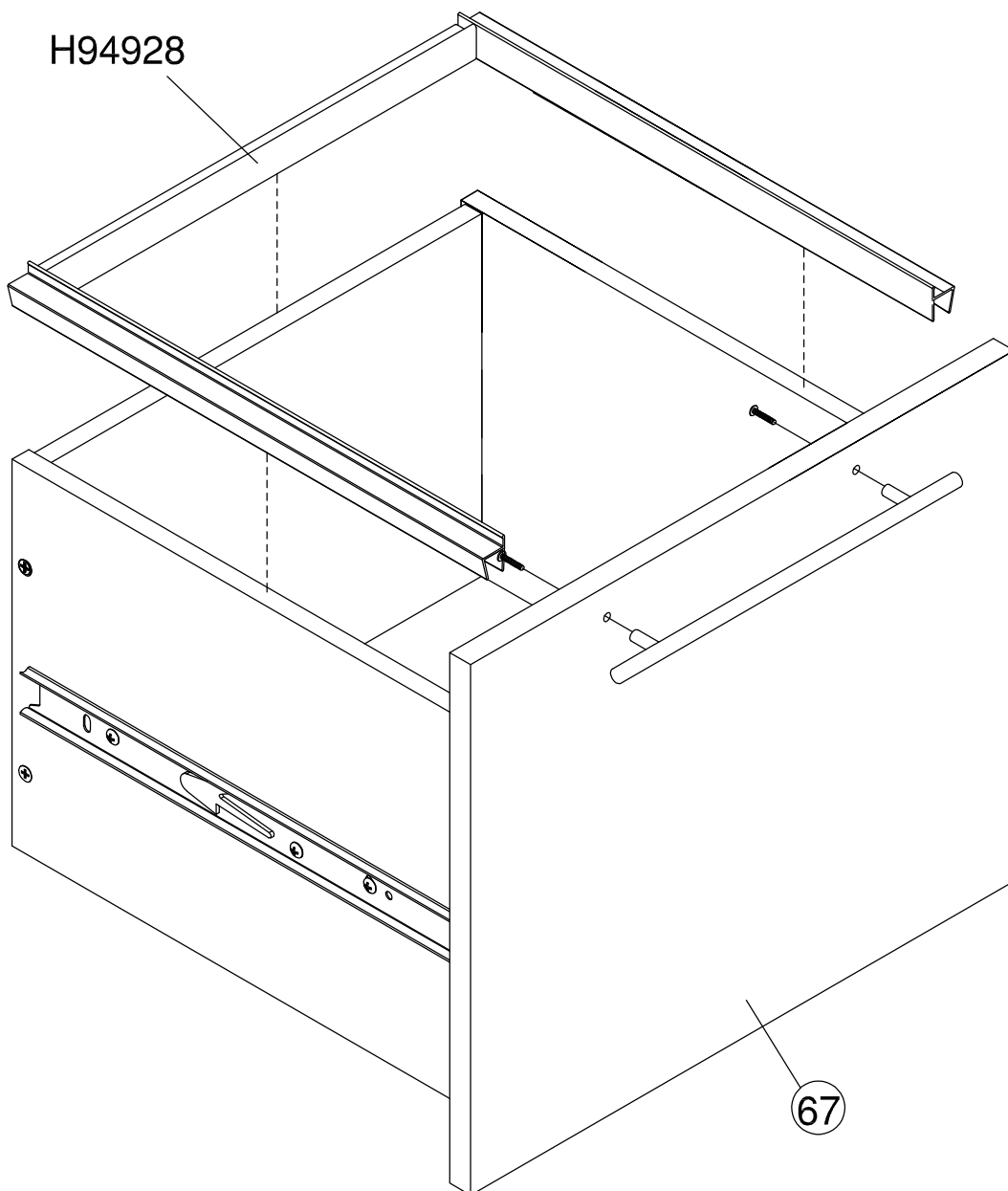

STEP 6

Prepare Drawer Front

H35251

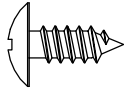

[2]

#10 x 1/2"

H100444

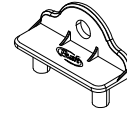

[2]

Drawer Bracket

H160460

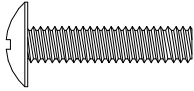

[2]

M4 x 22MM

H194566

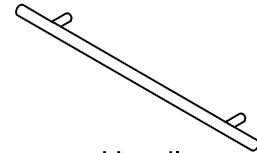

[1]

Handle

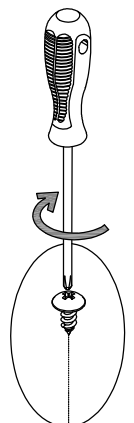
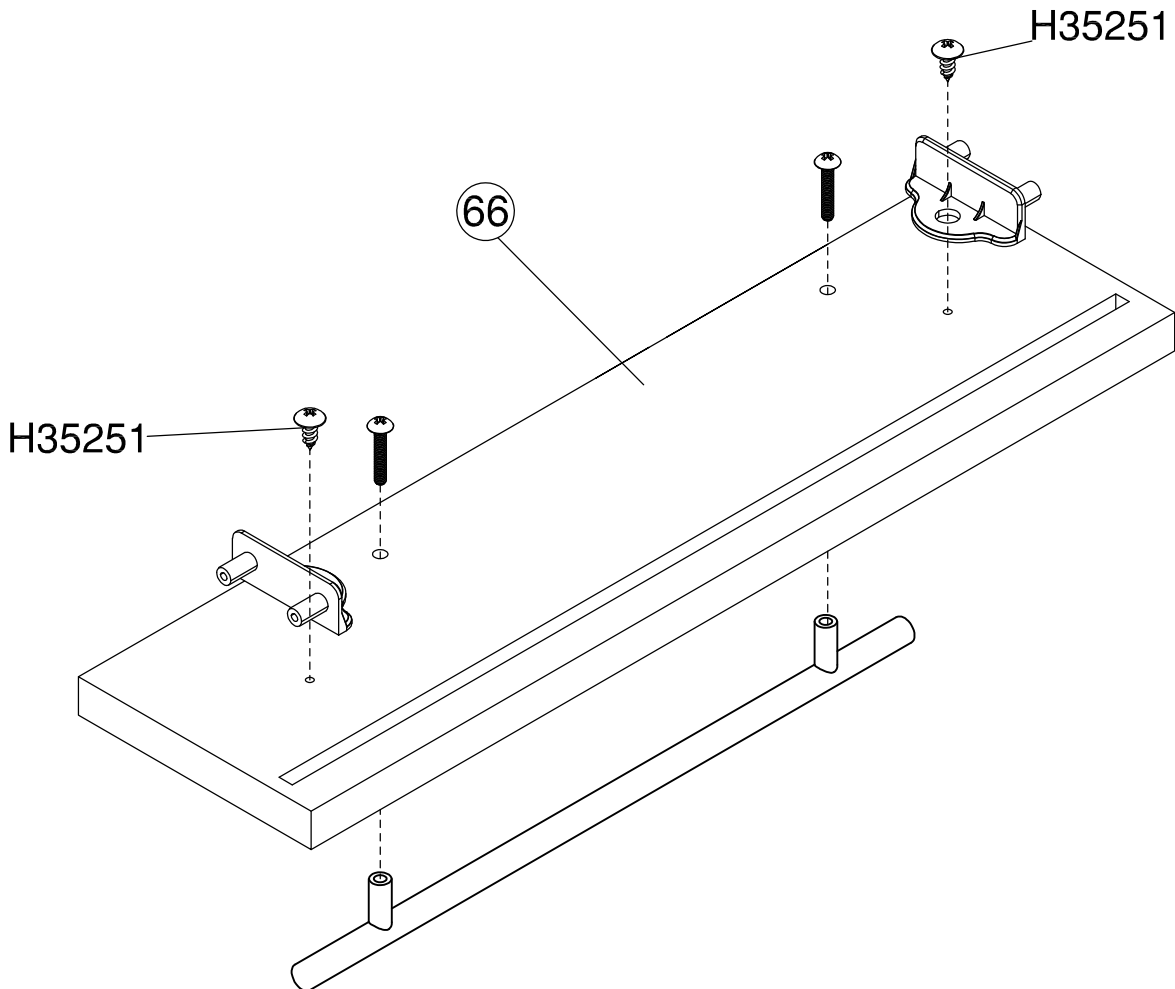

STEP 7

Assemble Drawer

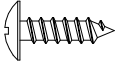
H101725  [4]
#6 x 1/2"

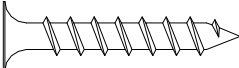
H26053  [4]
#10 x 1-1/4"

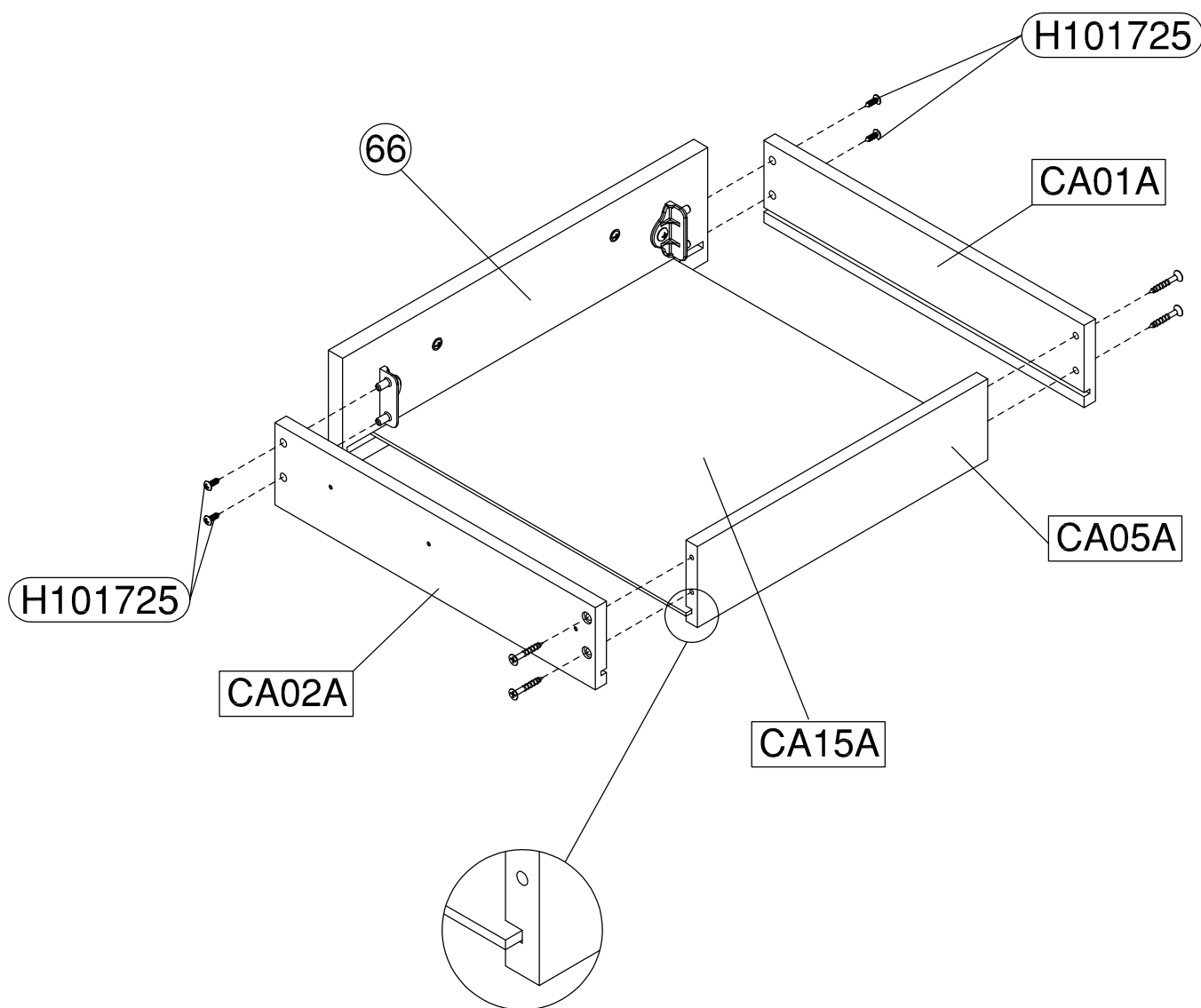

STEP 8

Install Slide Runners

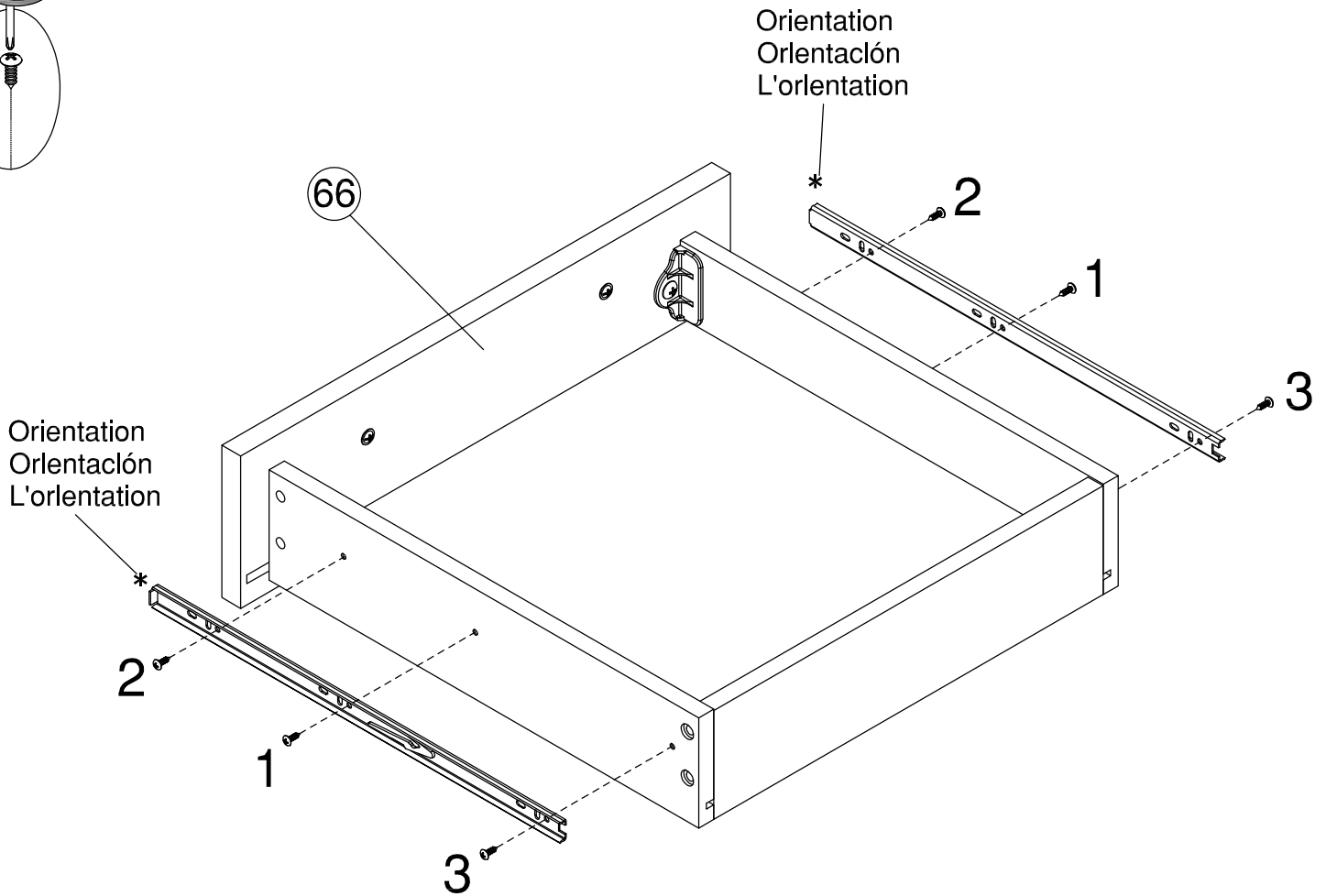
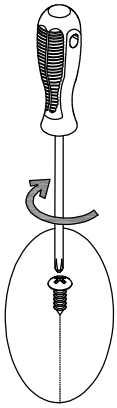
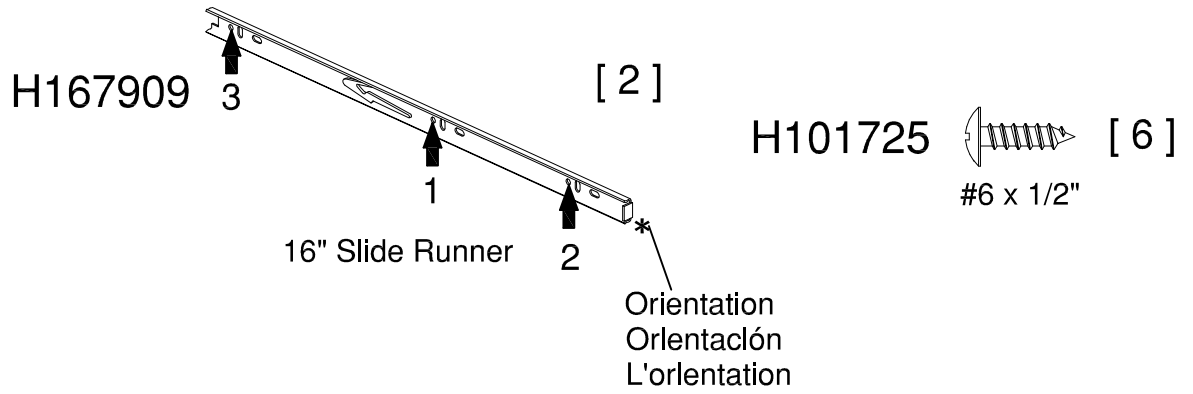

STEP 9

Install Slide

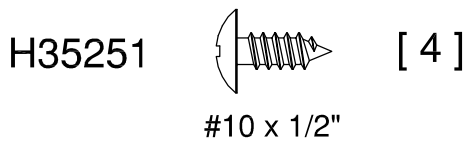
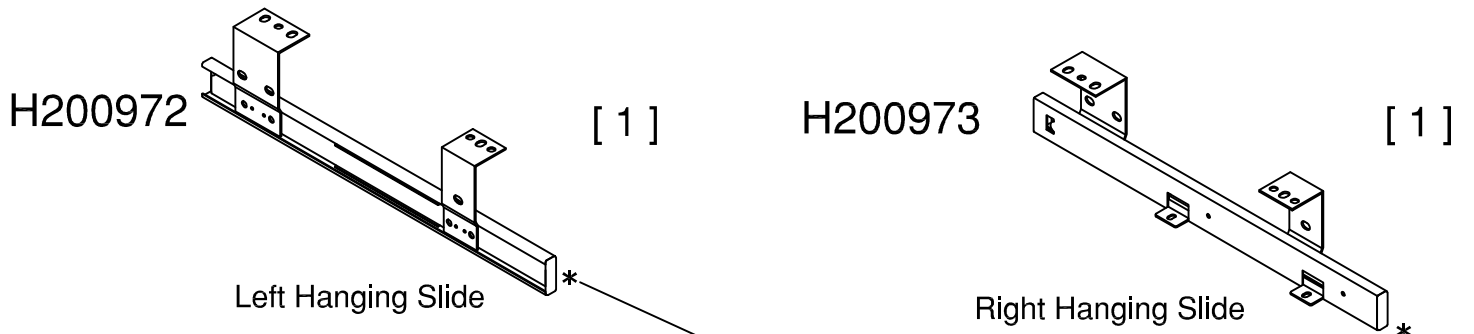

Orientation
Orientación
L'orientation

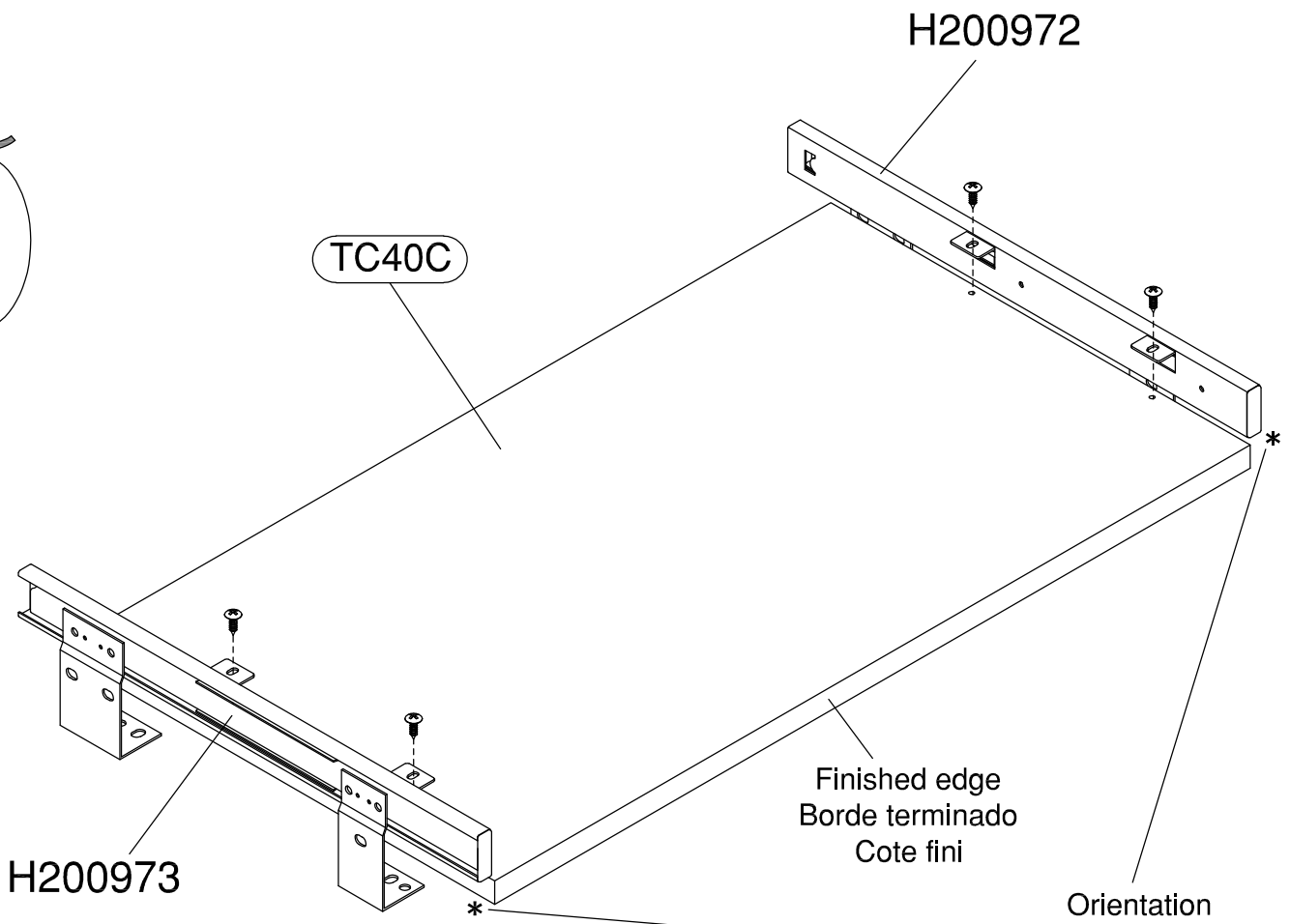
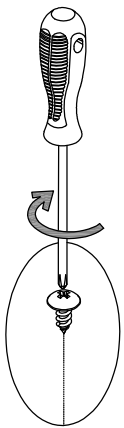

TC40C

H200972

H200973

Finished edge
Borde terminado
Cote fini

Orientation
Orientación
L'orientation

STEP 10

Prepare Panels

H137197

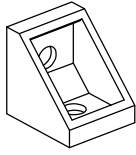

[5]

Plastic Bracket

H101725

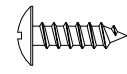

[5]

#6 x 1/2"

H166336

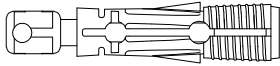

[6]

Quick Connect

H38169

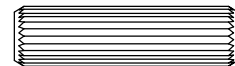

[4]

Wood Dowel
8 x 30mm

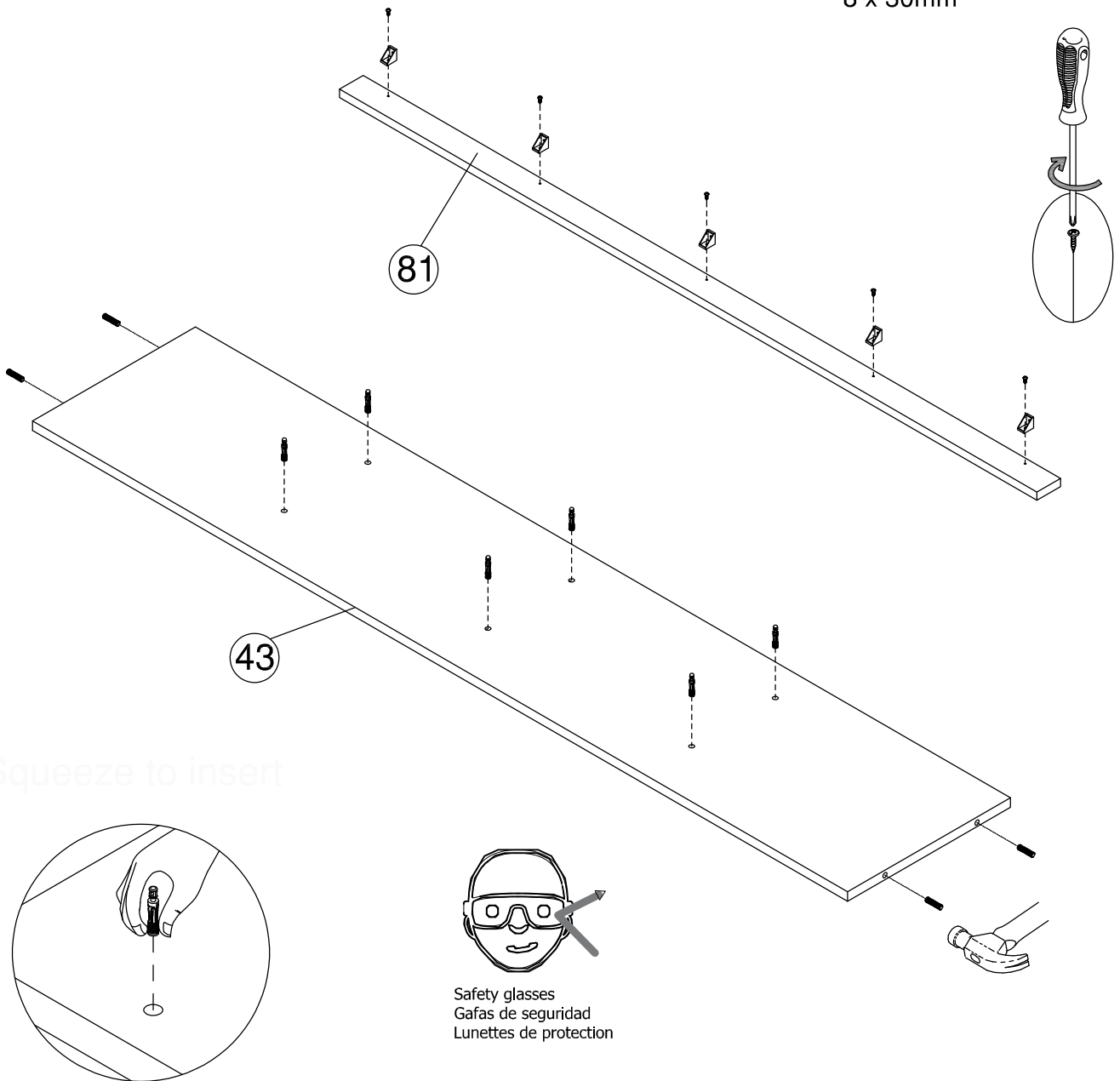

STEP 11

Assemble Panels

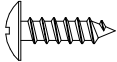
H101725  [5]
#6 x 1/2"

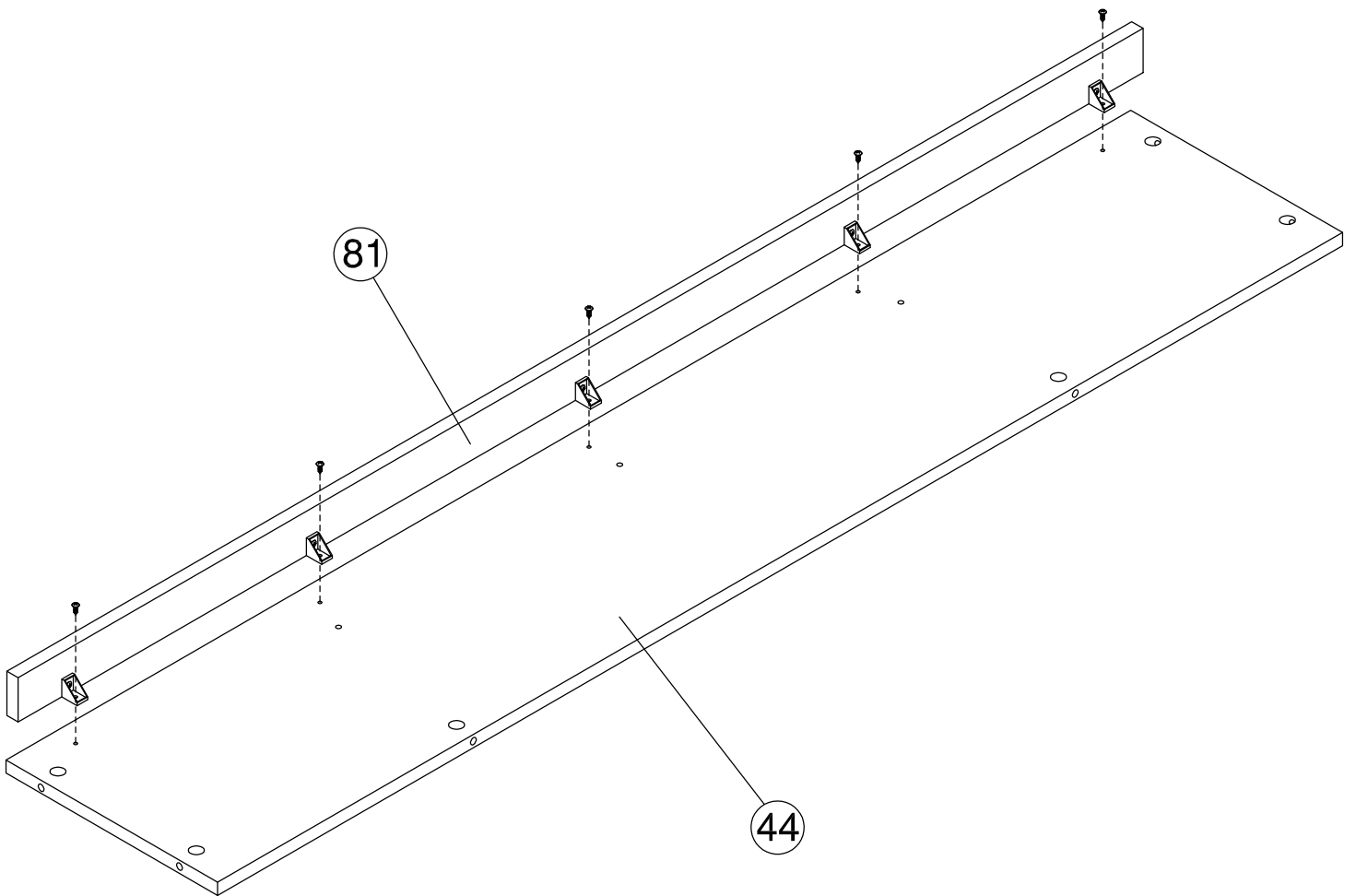

STEP 12

Assemble Panels

H181468

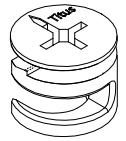

[6]

KD Cam

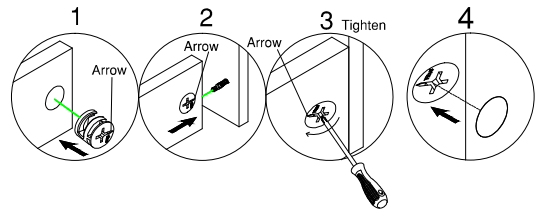

H170595

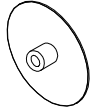

[6]

Cover Cap

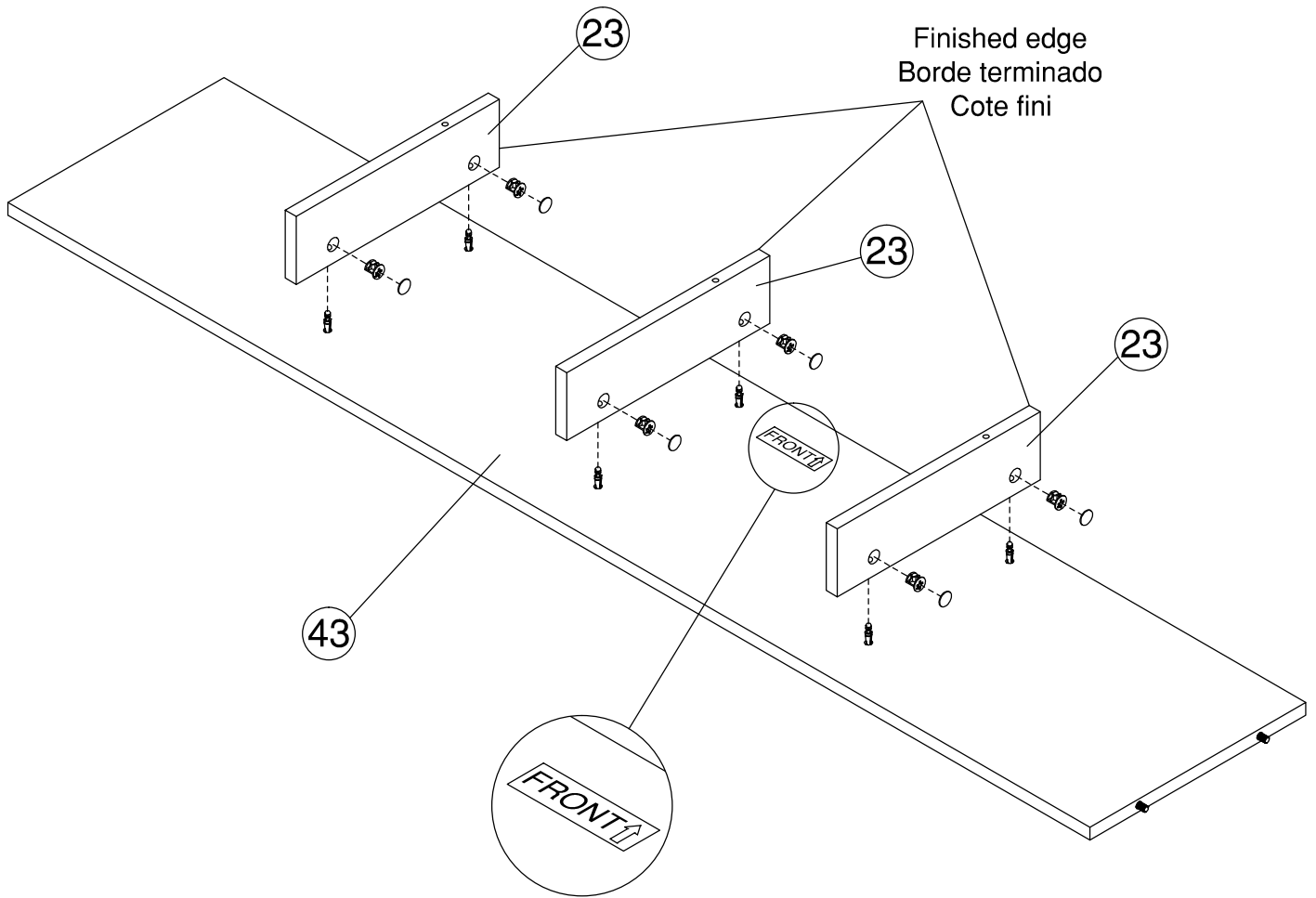

STEP 13

Assemble Panels

H150019

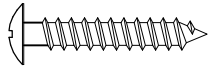

[3]

#8 x 1"

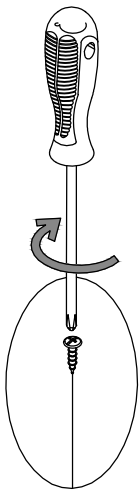
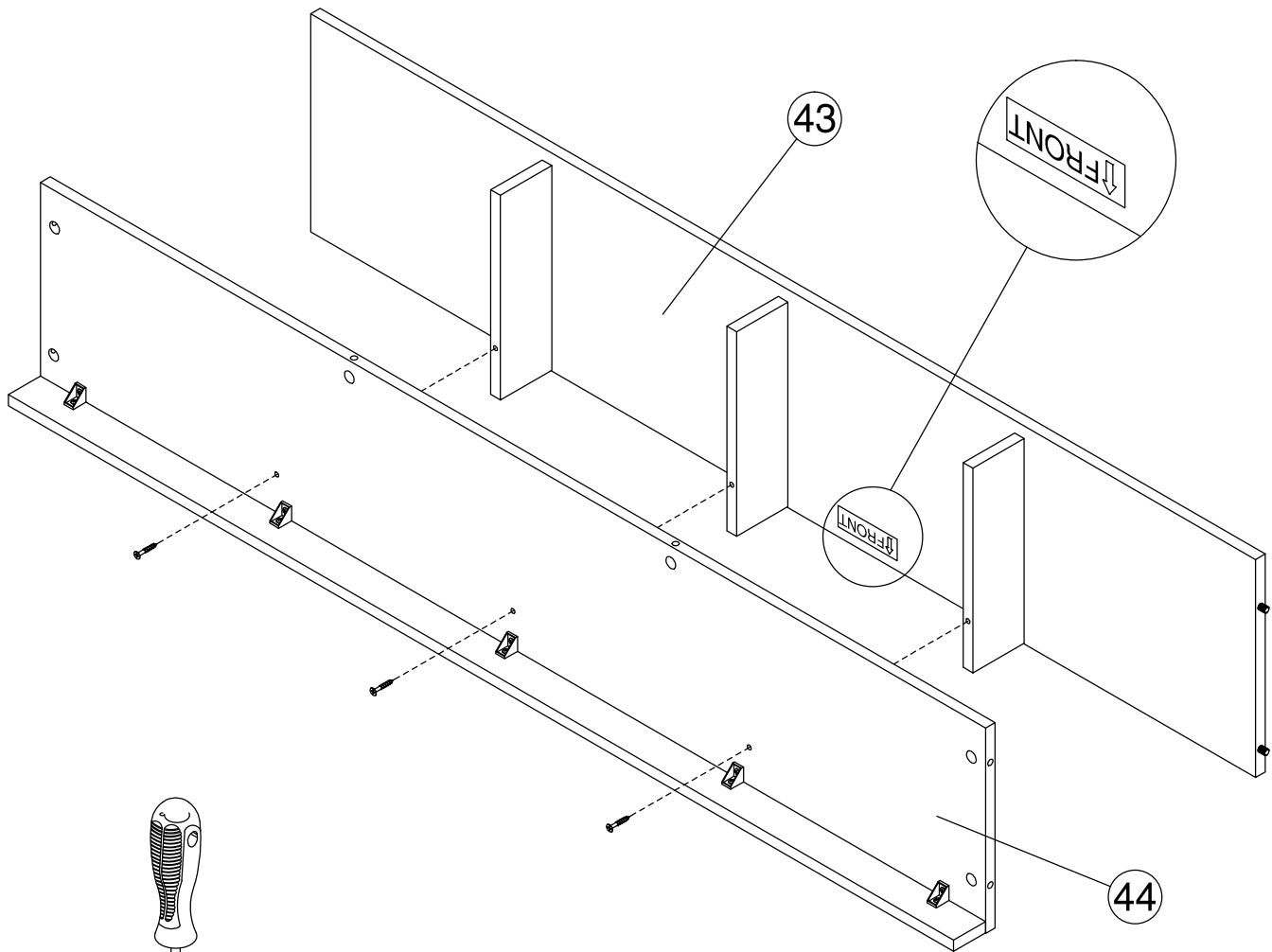

STEP 14

Prepare Panel

H166336

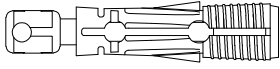

[2]

Quick Connect

Squeeze to insert

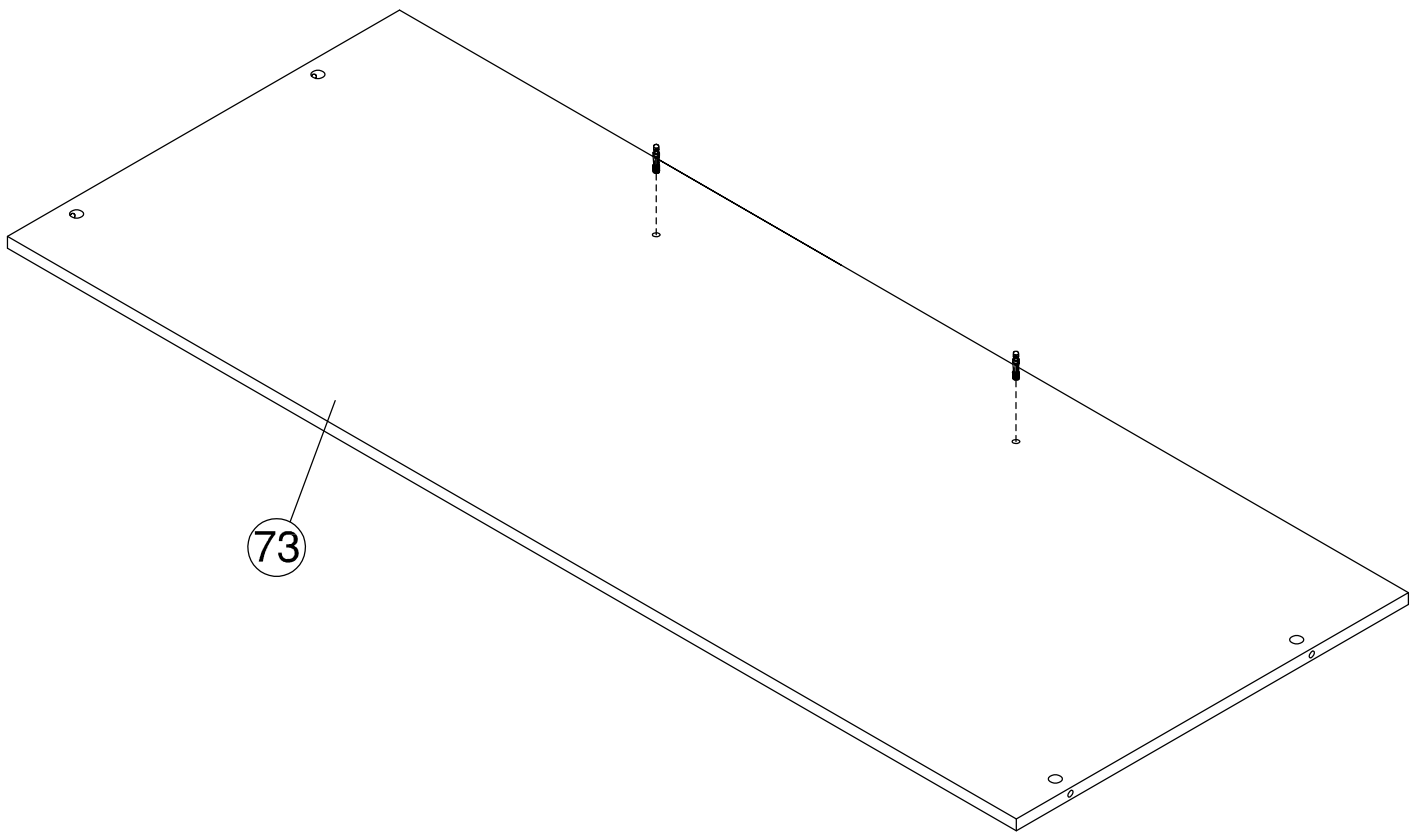
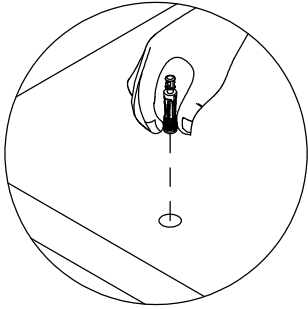

STEP 15

Assemble Panels

H181468 [2]
KD Cam

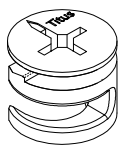

KD Cam

H170595 [2]
Cover Cap

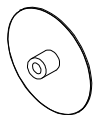

Cover Cap

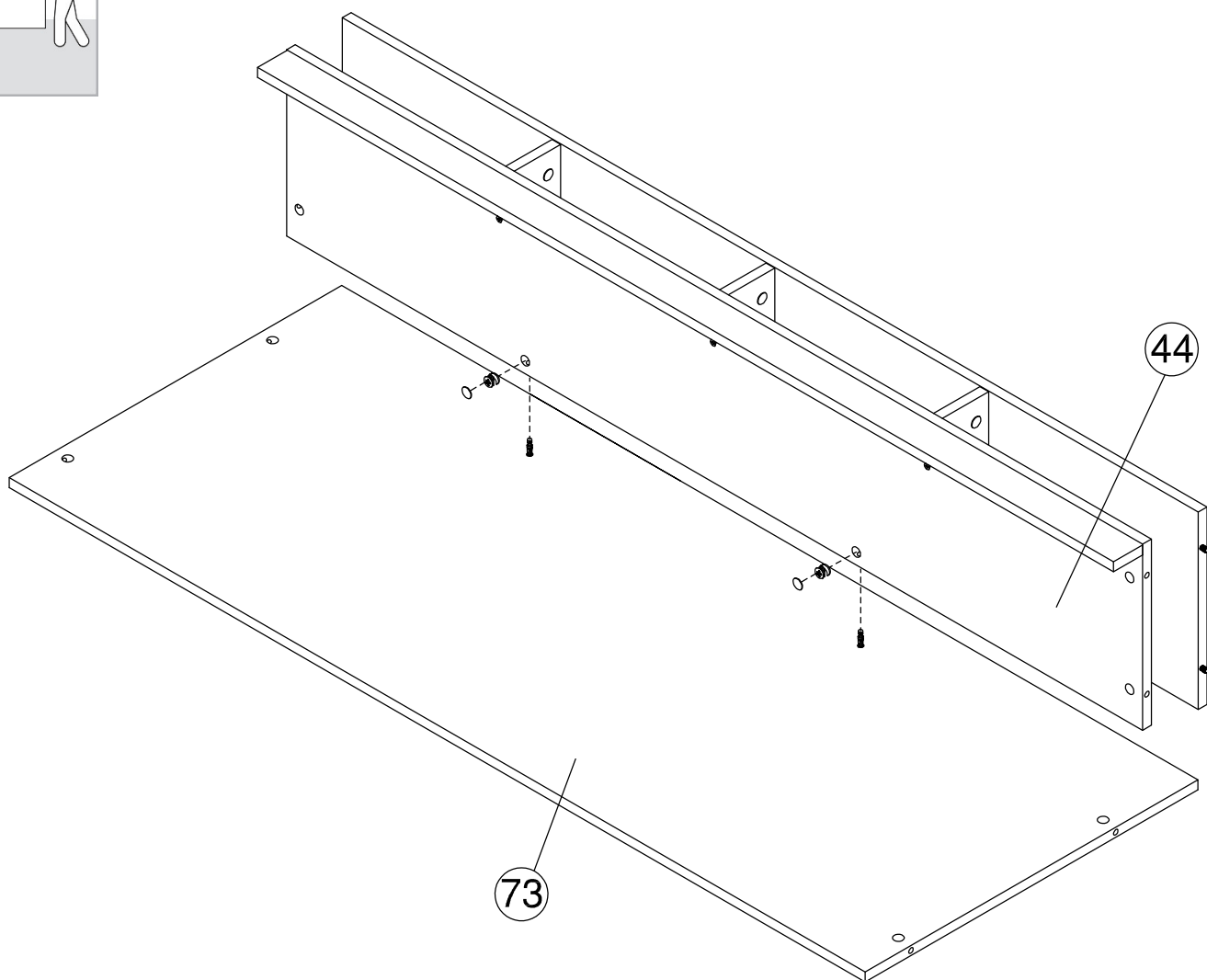
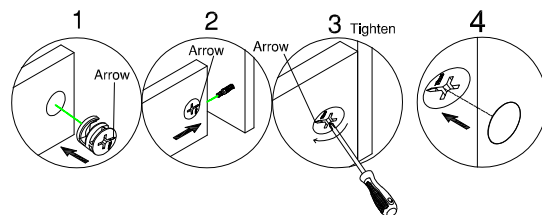

STEP 16

Prepare Panels

H166336

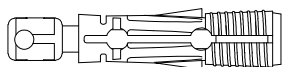

[8]

Quick Connect

H166306

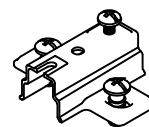

[4]

Mounting Plate

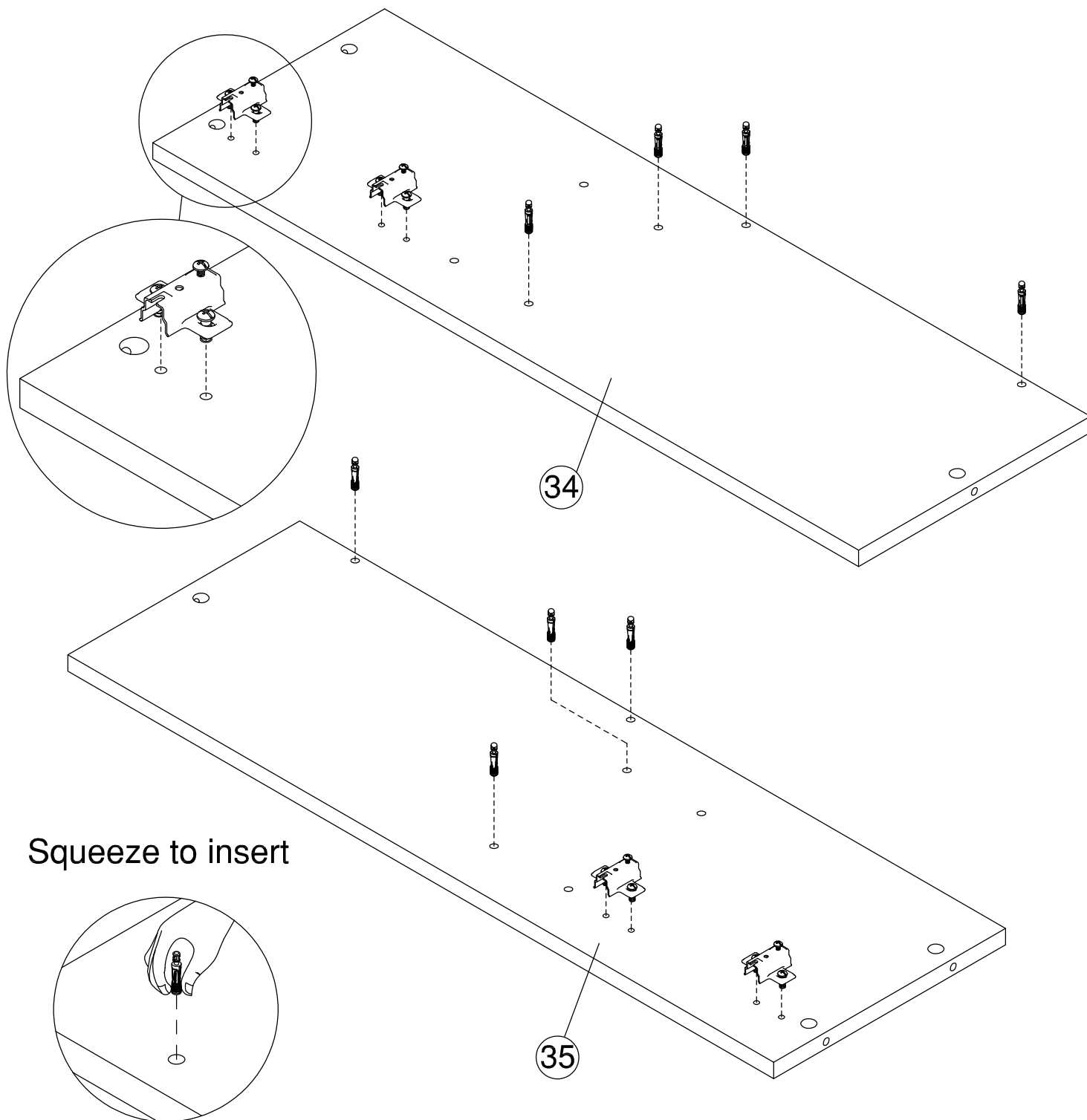

Squeeze to insert

STEP 17

Assemble Panels

H181468

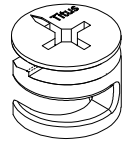

KD Cam

[8]

H170595

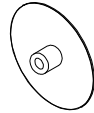

Cover Cap

[8]

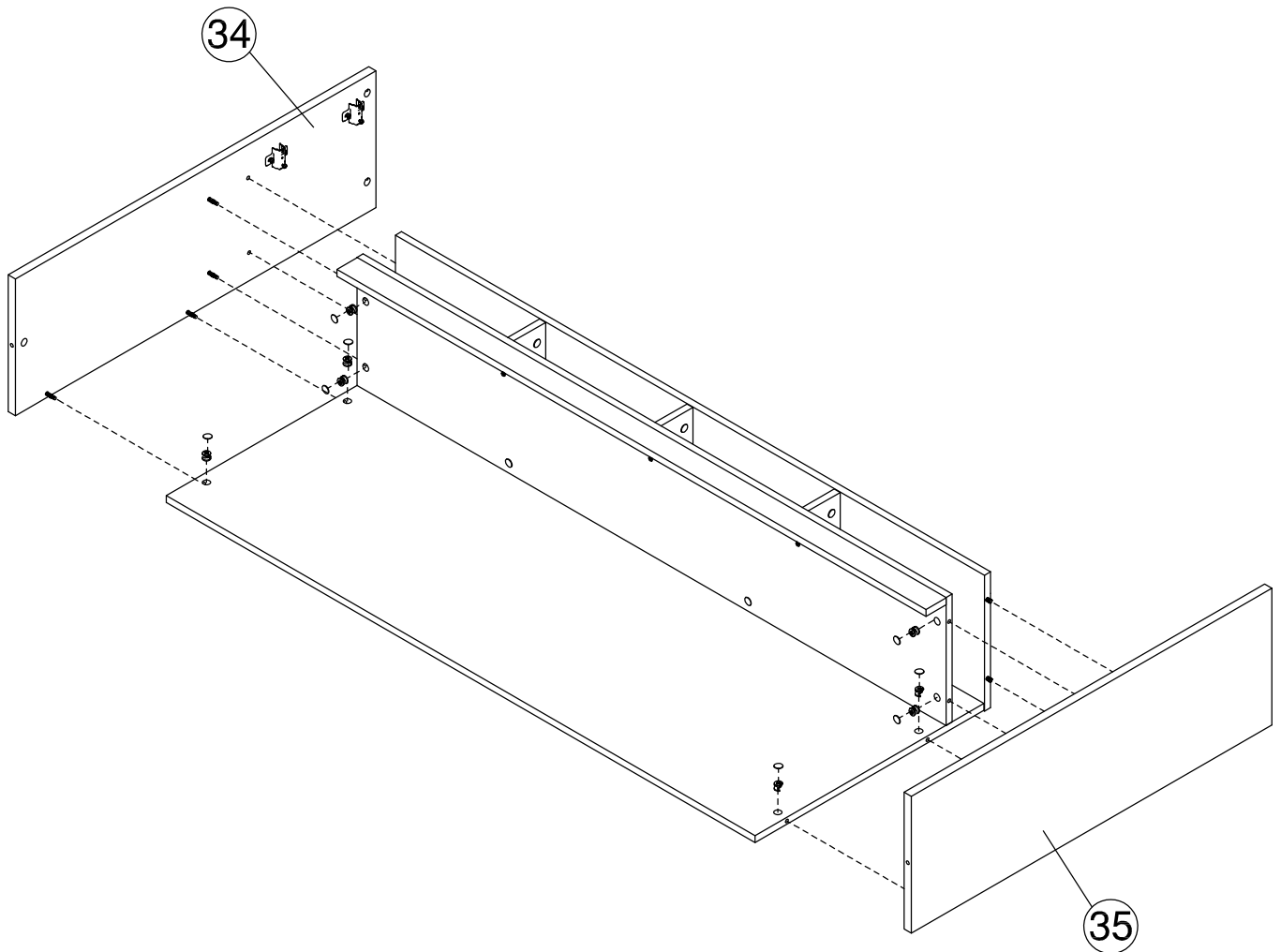
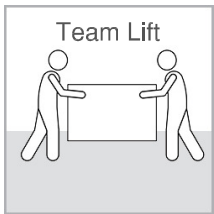
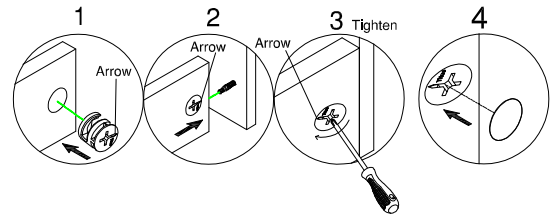

STEP 18

Prepare Panels

H201027

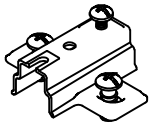

[4]

Mounting Plate

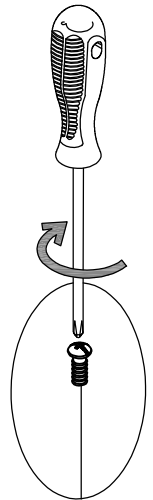
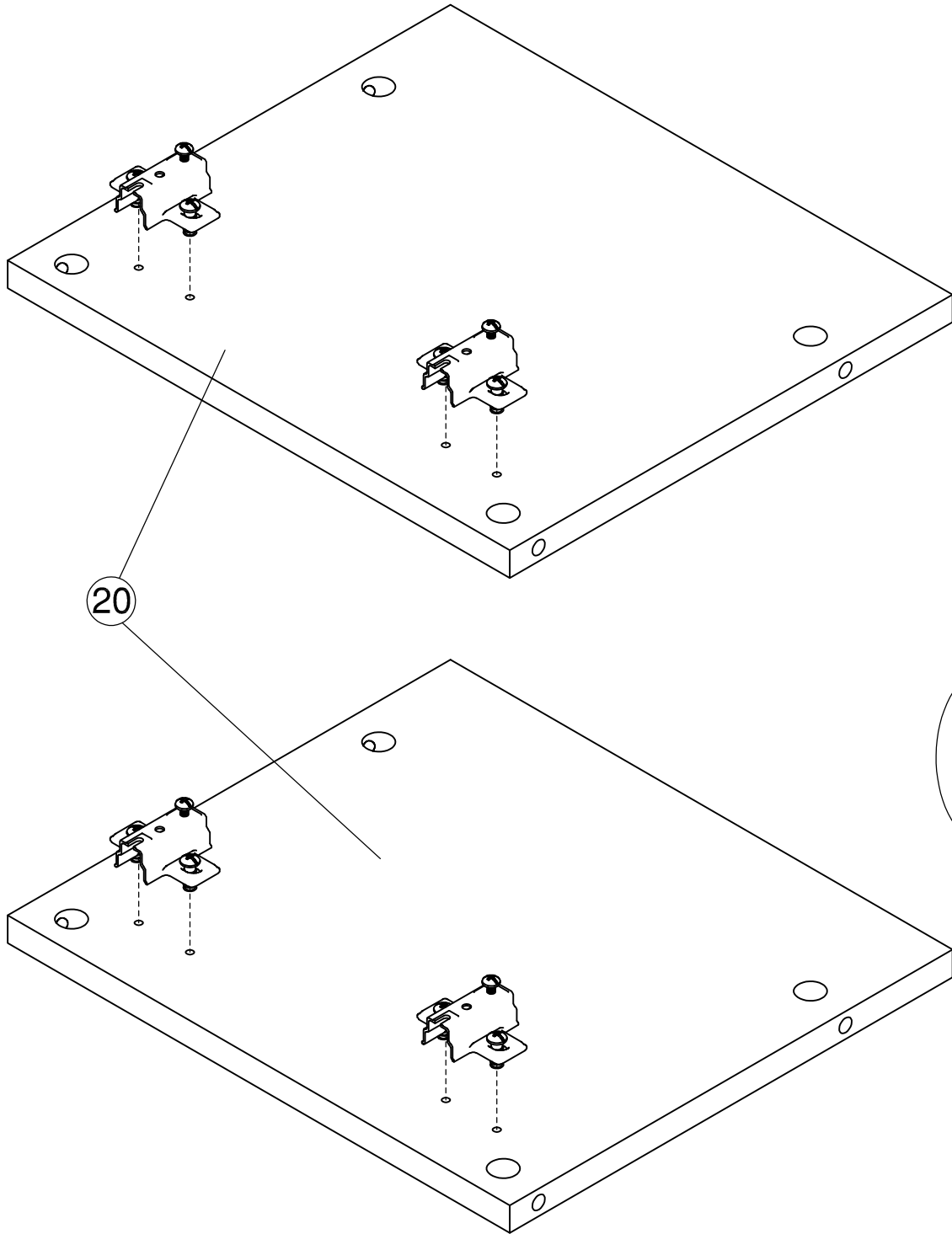

STEP 19

Install Hardware

H166336

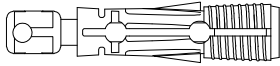

[4]

Quick Connect

Squeeze to insert

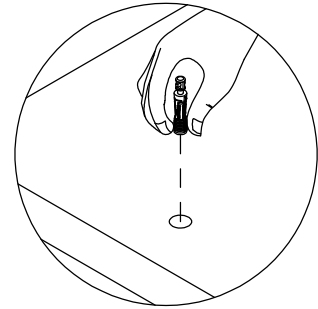
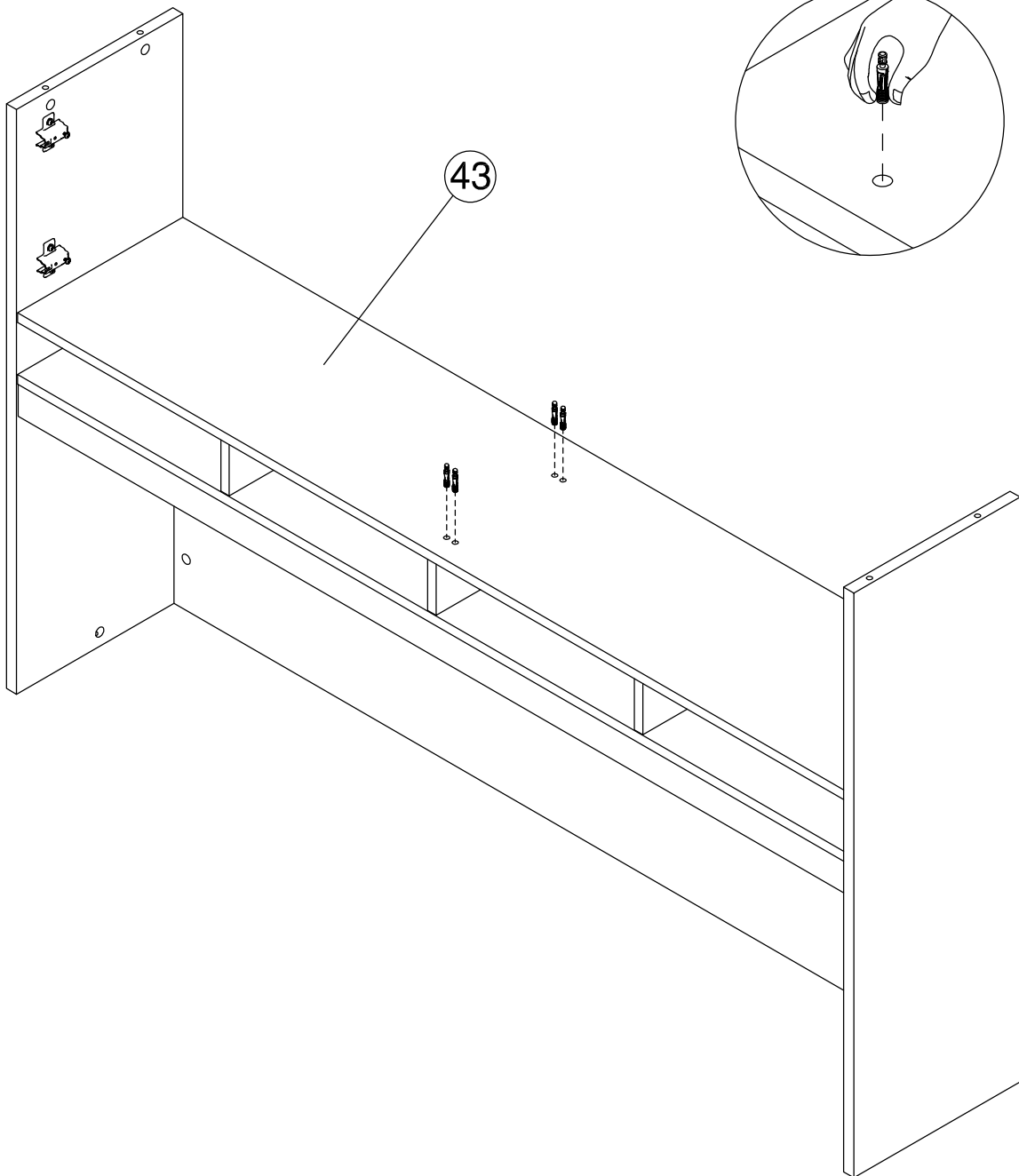

STEP 20

Assemble Panels

H181468 [4]
KD Cam

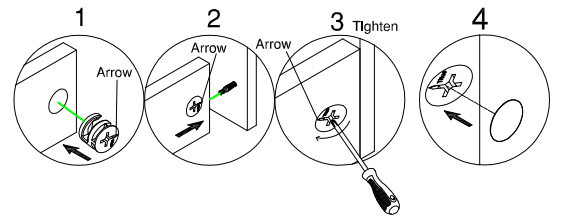
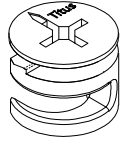

H170595 [4]
Cover Cap

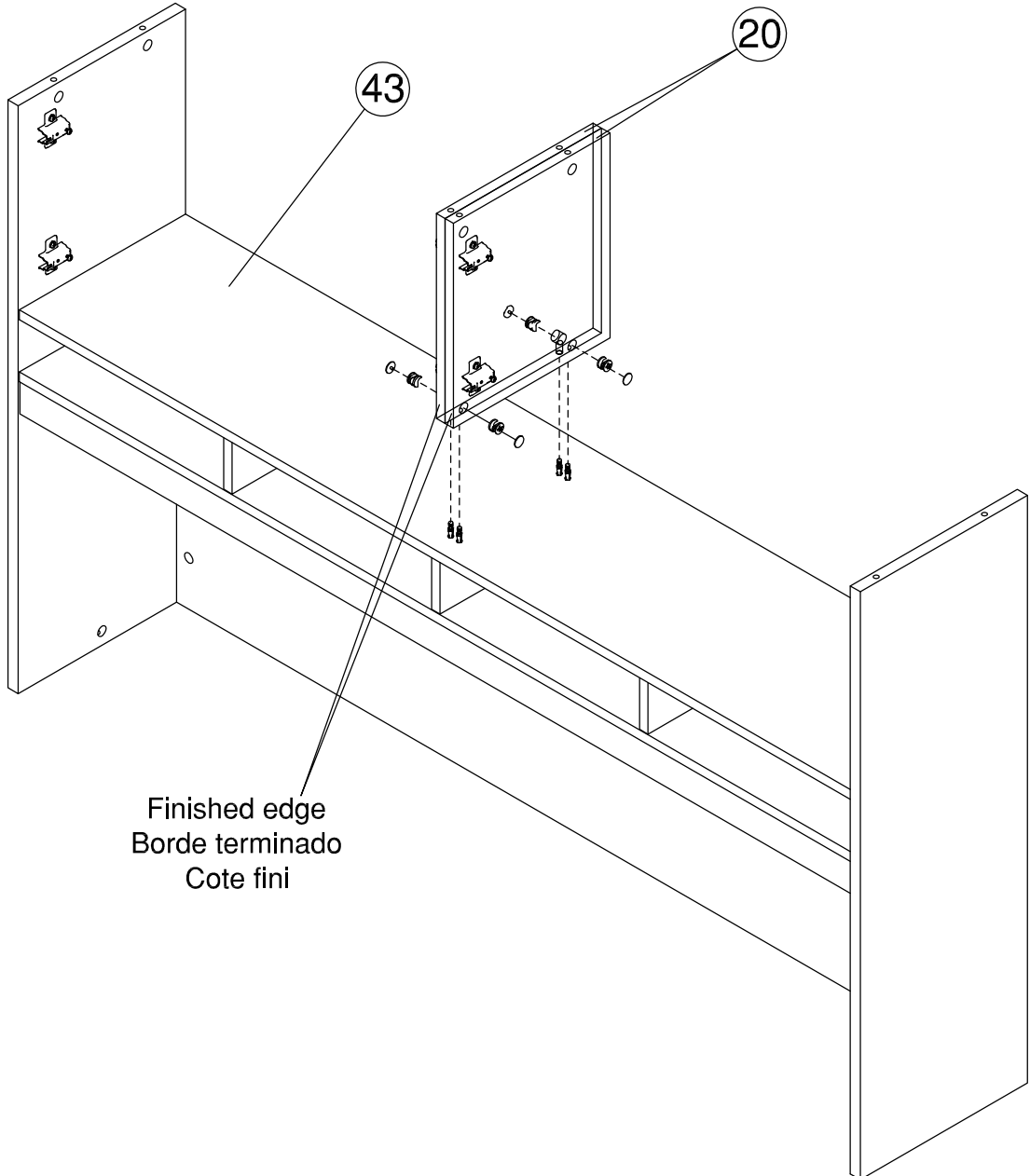
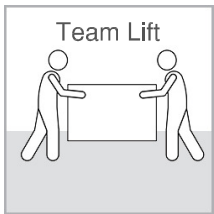
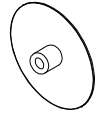

STEP 21

Prepare Panel

H180871

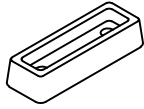

[2]

Door Stopper

H153243

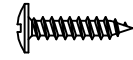

[4]

#5x9/16"

H166336

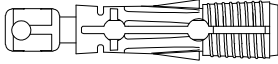

[8]

Quick Connect

Squeeze to insert

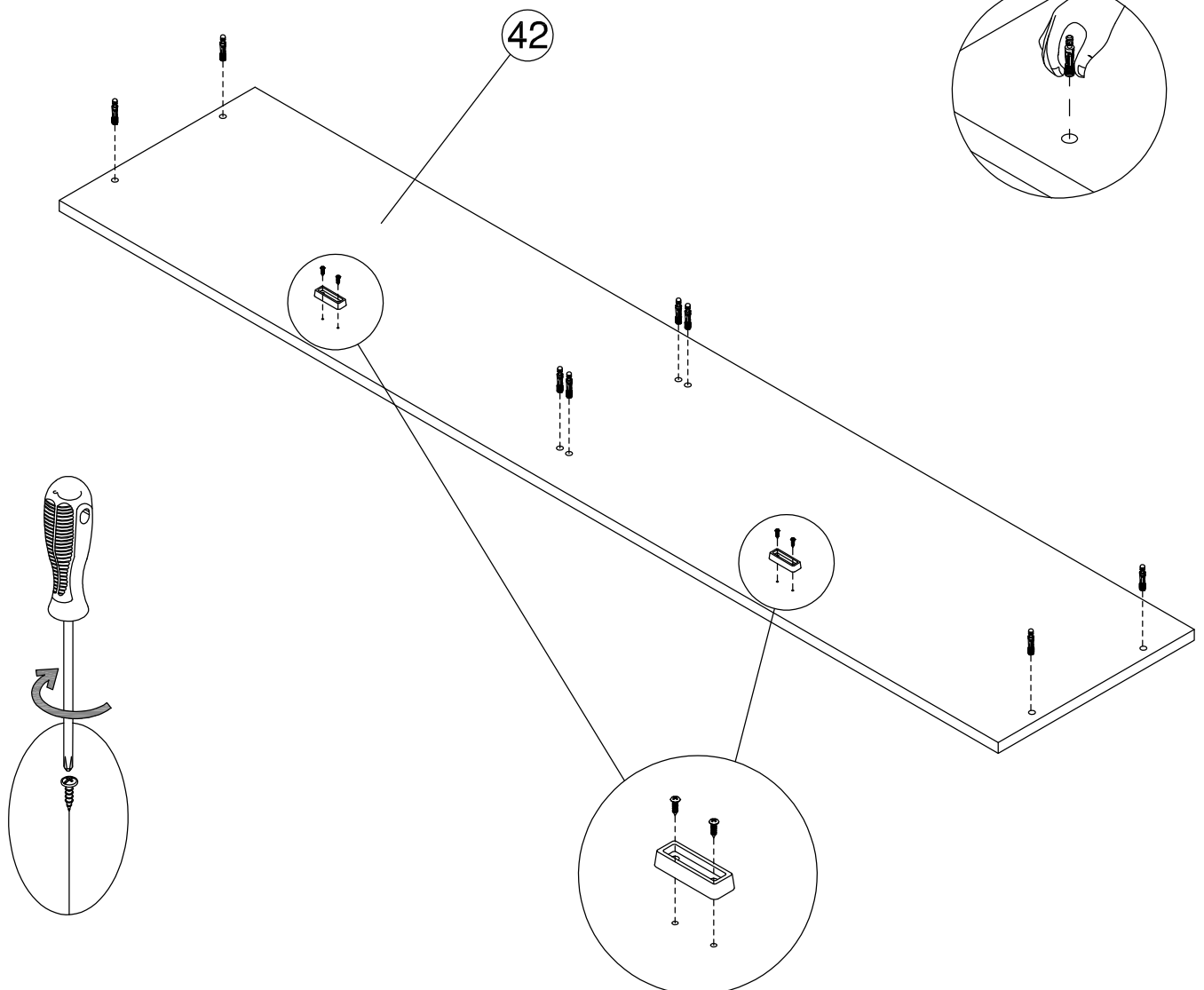

STEP 22

Assemble Panels

H181468

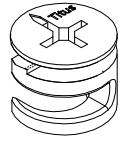

[8]

KD Cam

H170595



[8]

Cover Cap

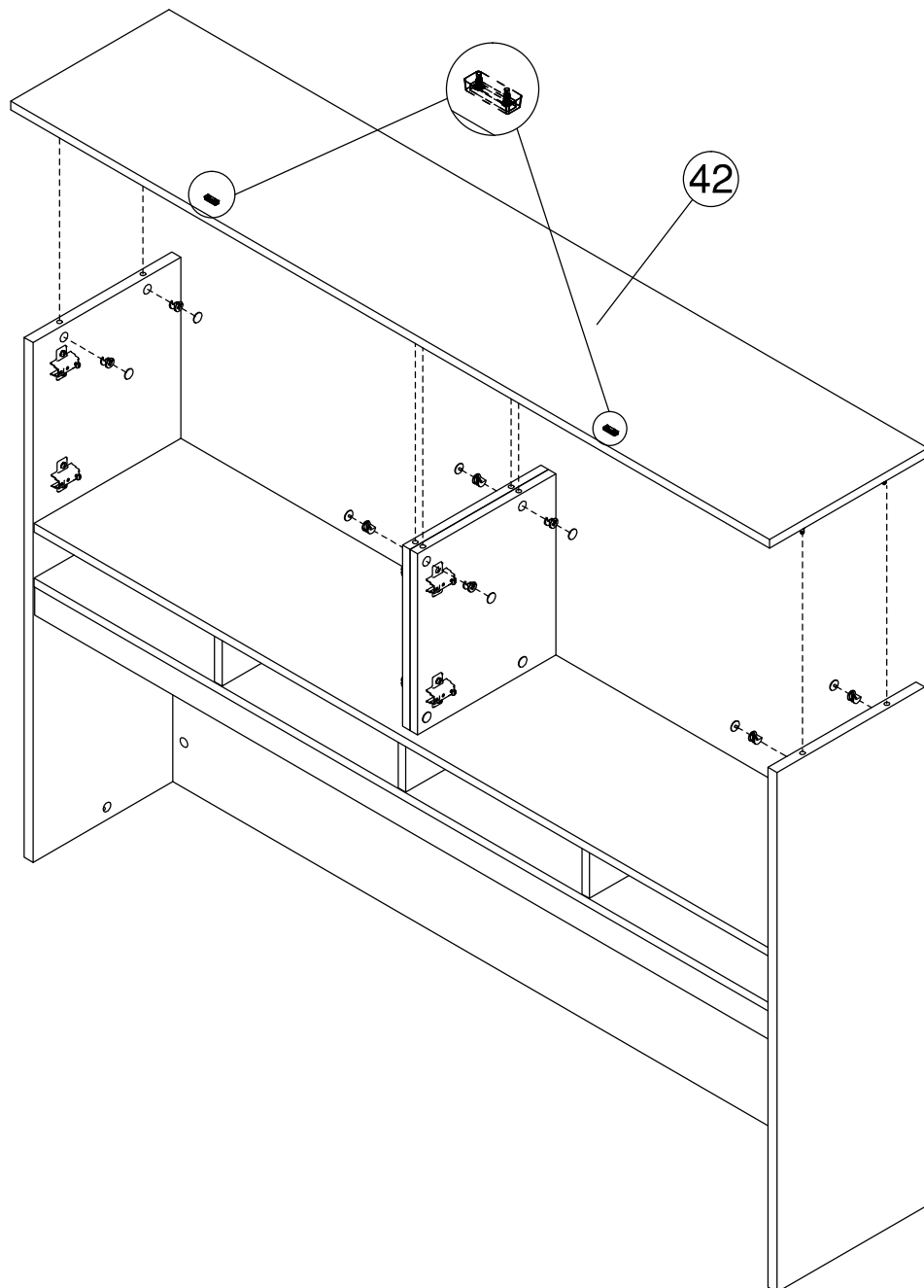
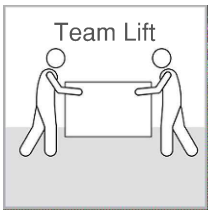
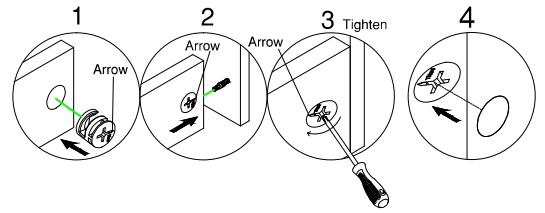

STEP 23

Attach Back Panel

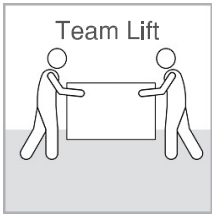

H186067



[20]

#3 x 3/4" NICKEL

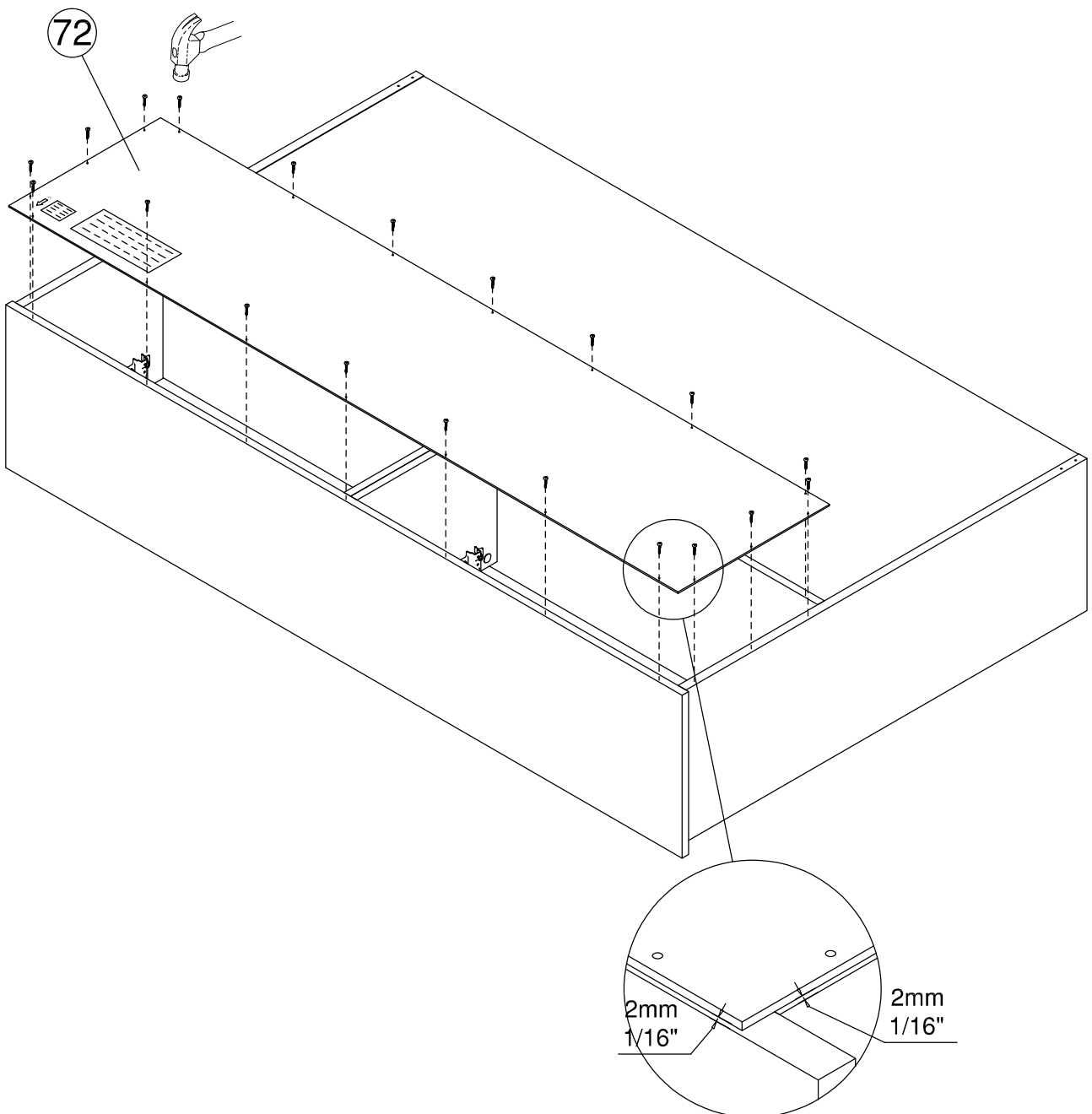

STEP 24

Assembly Options

Go to step 25
Proceda al paso 25
Allez a l'etape 25

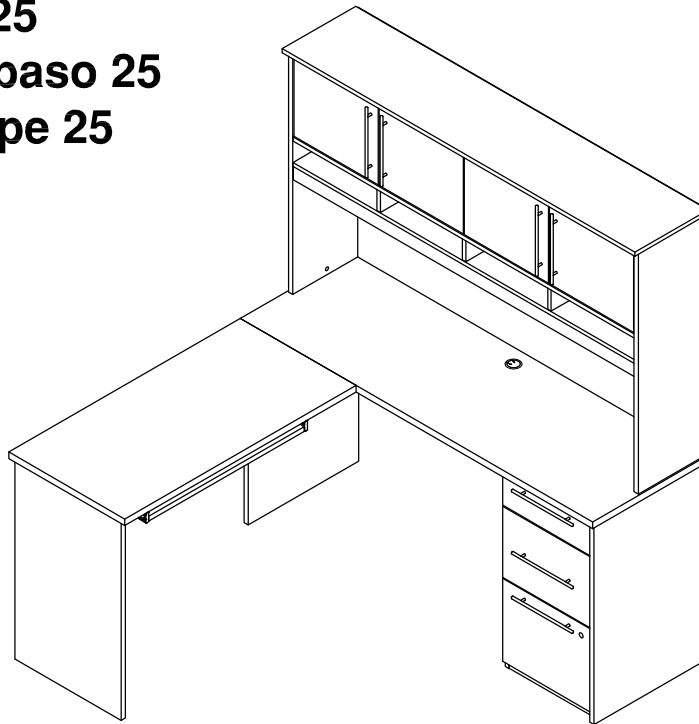

Go to step 40
Proceda al paso 40
Allez a l'etape 40

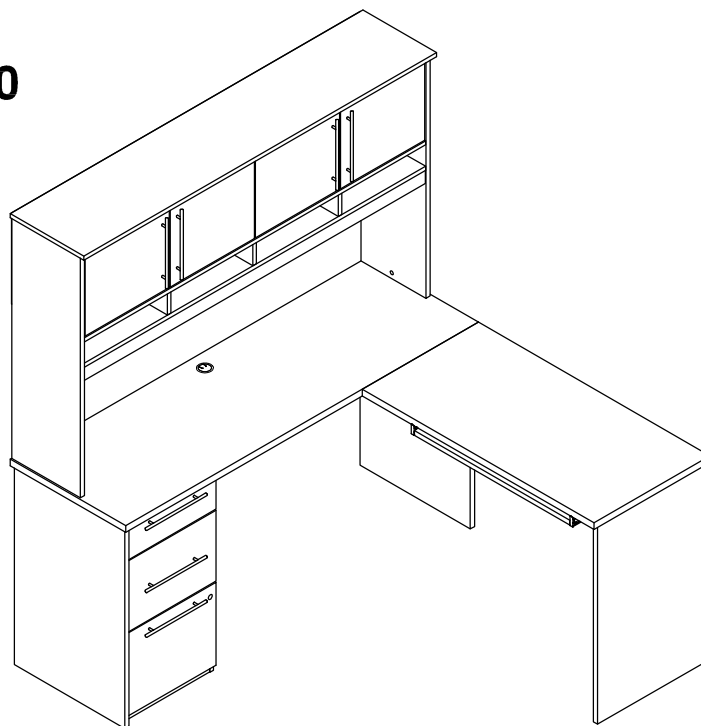

STEP 25

Prepare Panel

H182573  [4]
Cover Cap 5mm

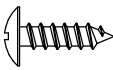
H101725  [6]
#6 x 1/2"

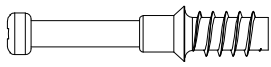
H180604  [6]
KD Bolt

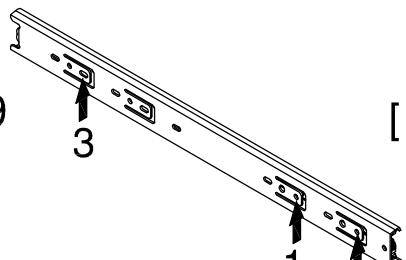
H167909  [2]

16" Slide Mount

Orientation
Orientación
L'orientation

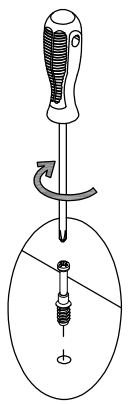
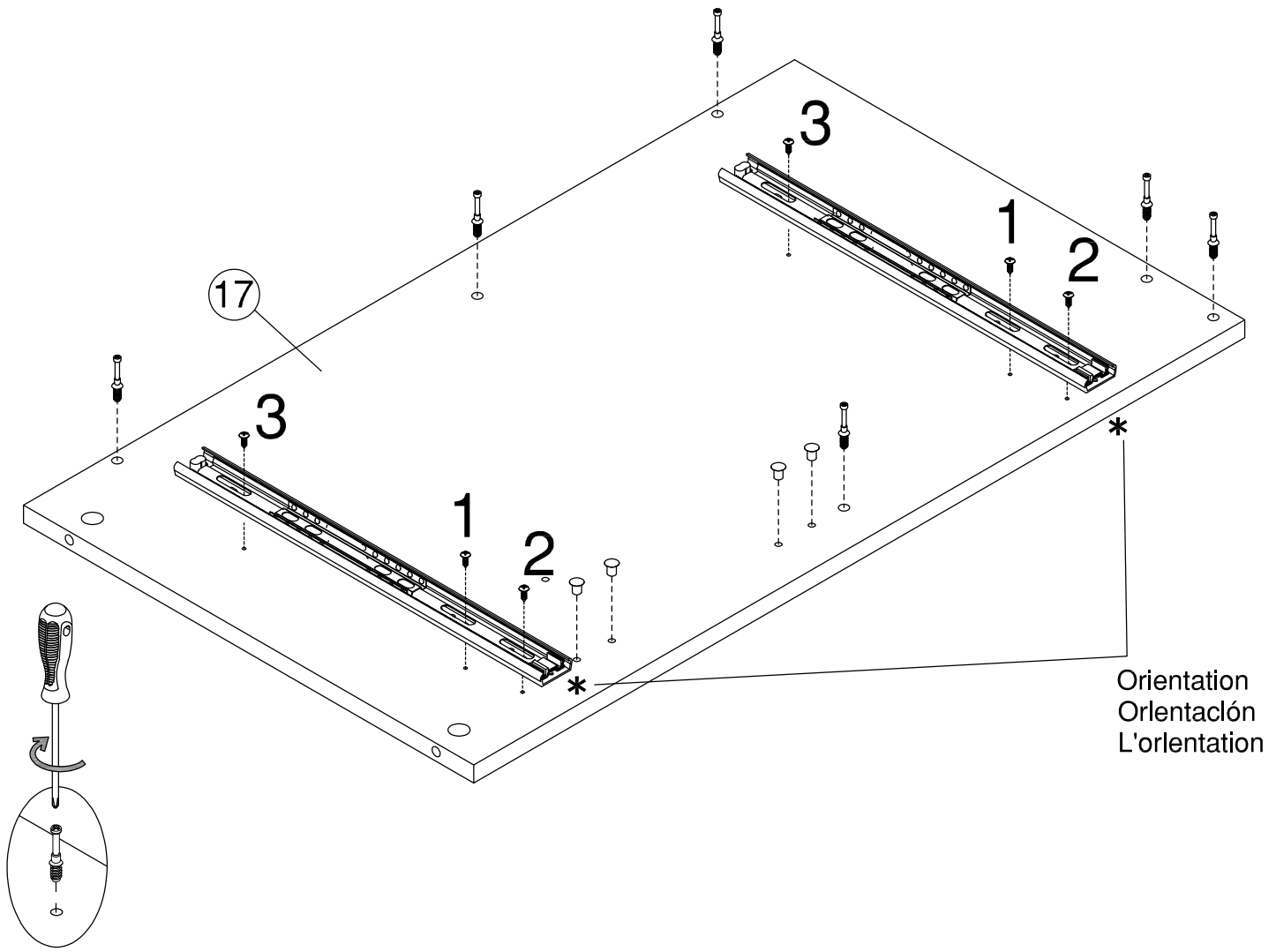

STEP 26

Prepare Panel

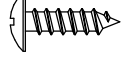
H101725  [6]
#6 x 1/2"

H180604  [6]
KD Bolt

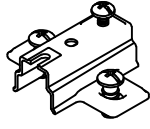
H201027  [2]
Mounting Plate

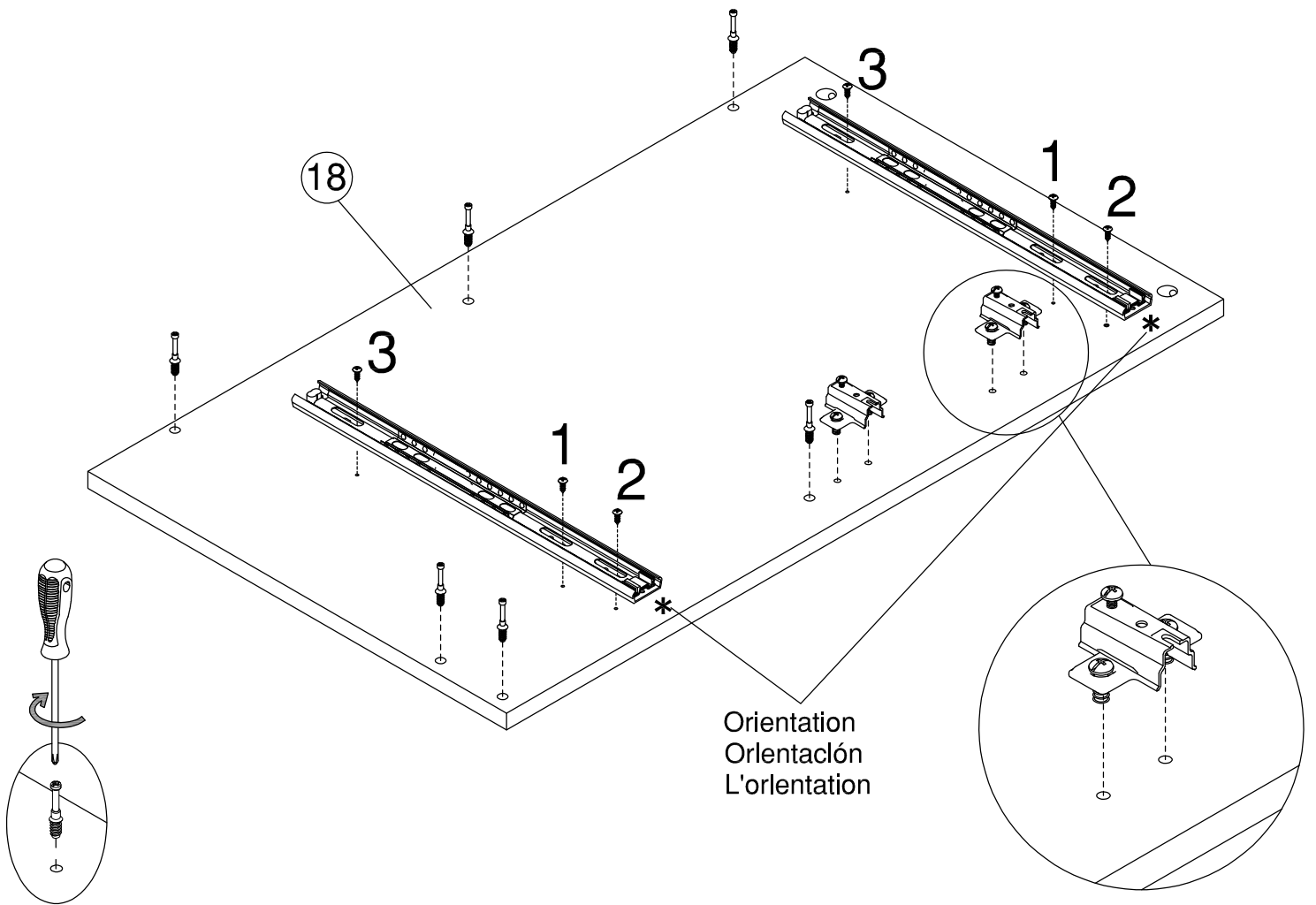
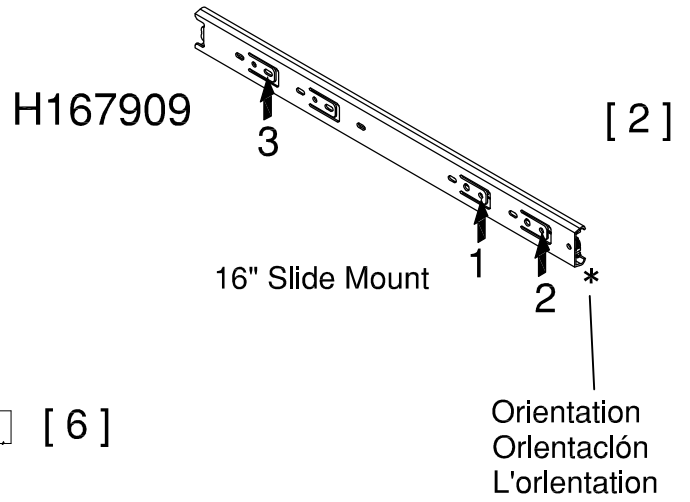

STEP 27

Prepare Panel

H153243



[2]

#5x9/16"

H199615

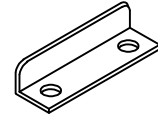

[1]

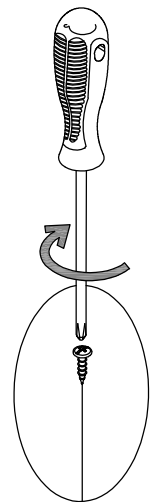
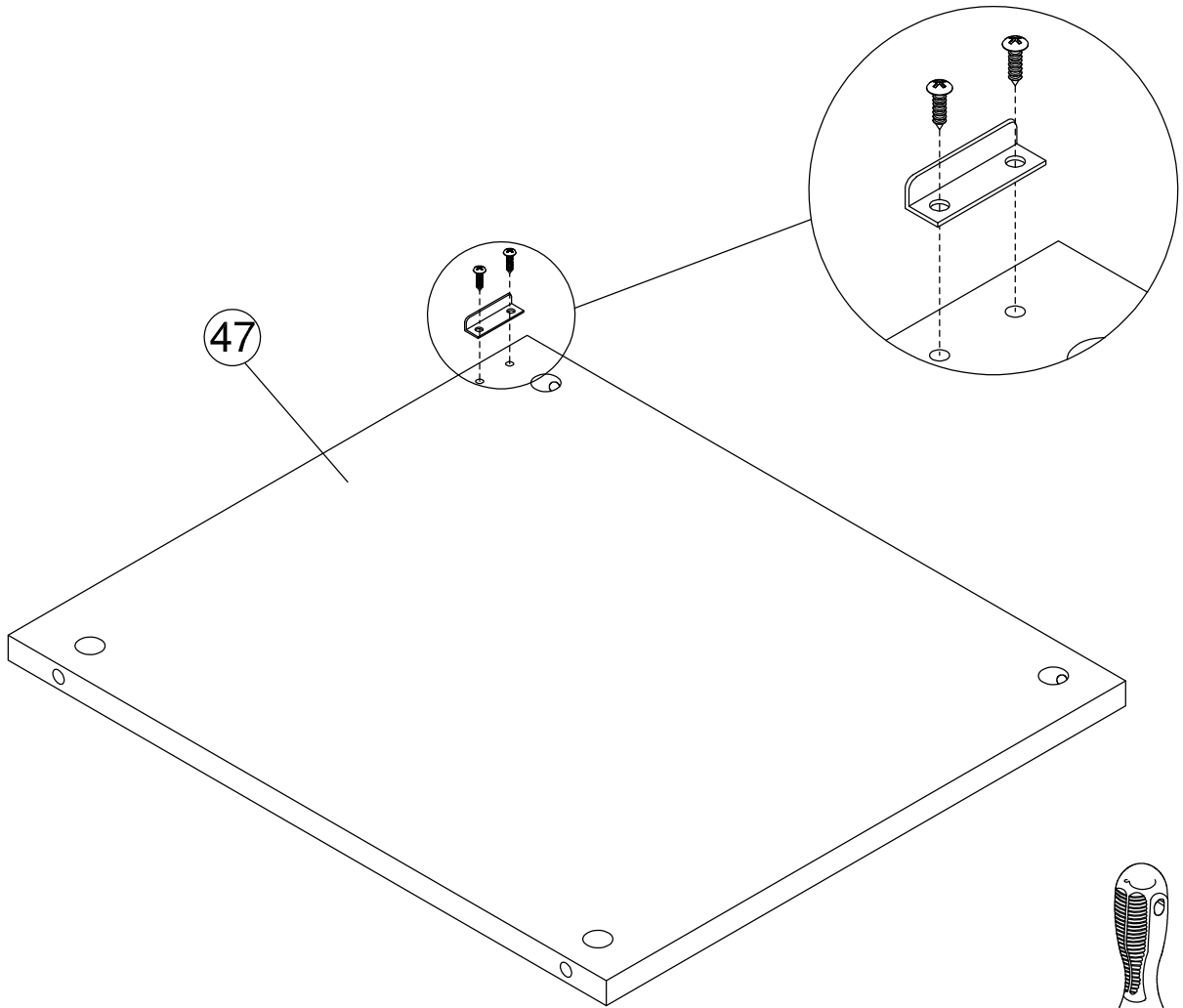

STEP 28

Assemble Panels

H181468

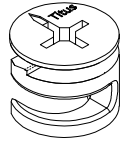

[6]

KD Cam

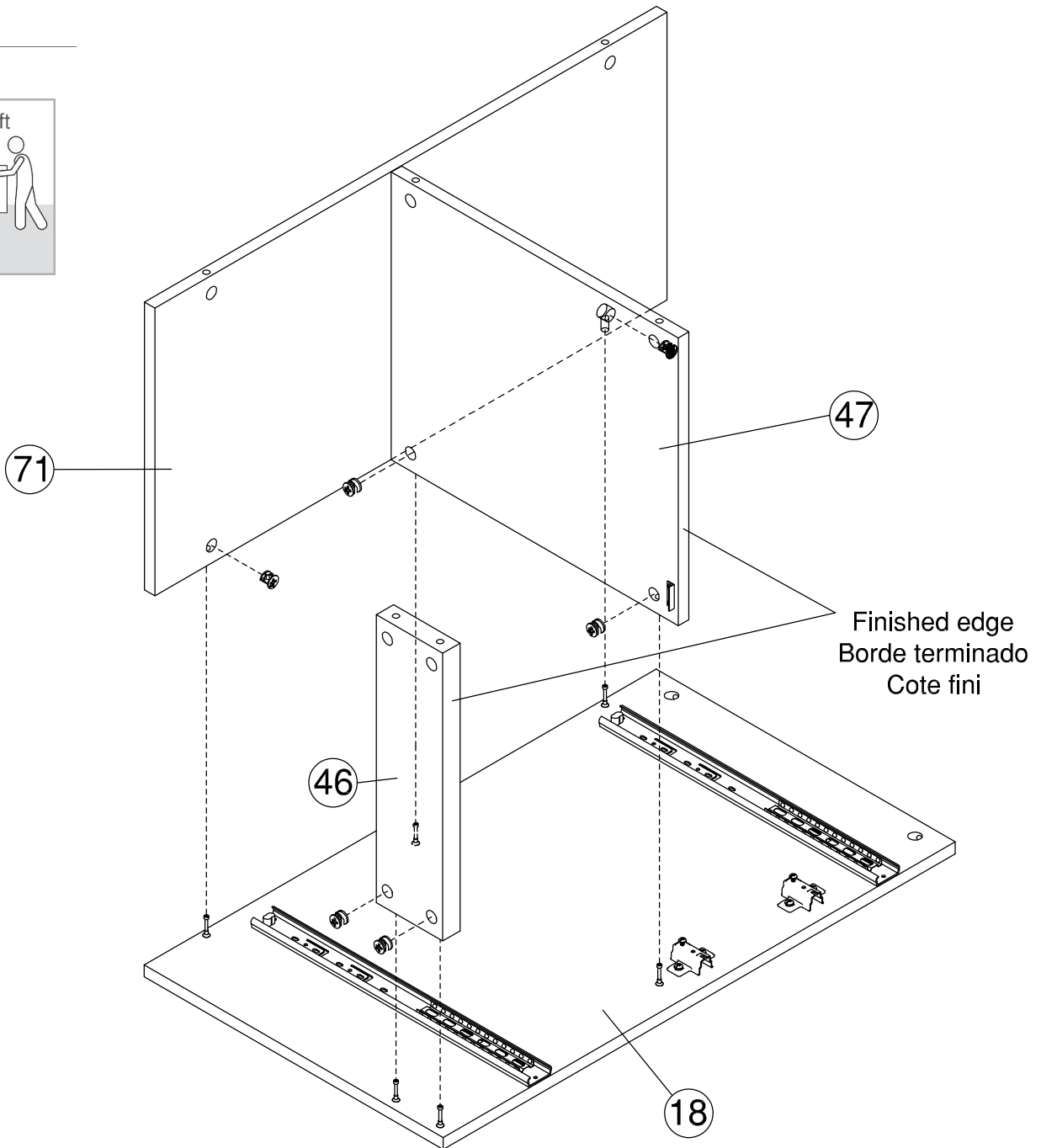
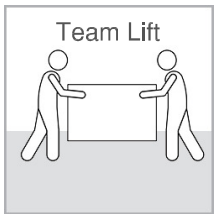
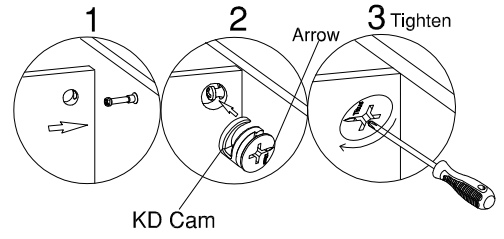

STEP 29

Assemble Panels

H181468

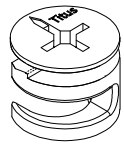

[6]

KD Cam

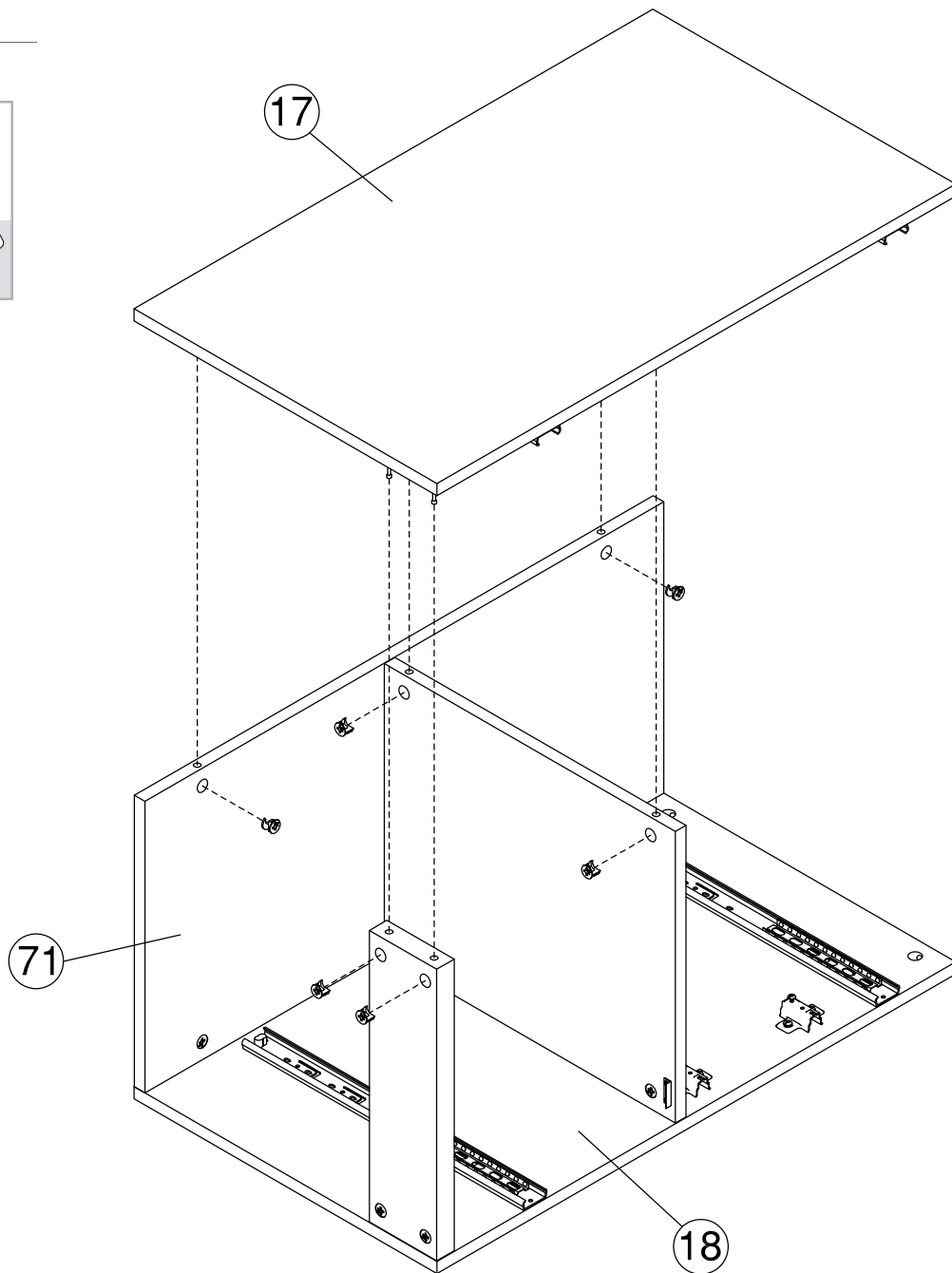
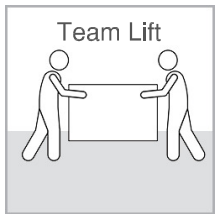
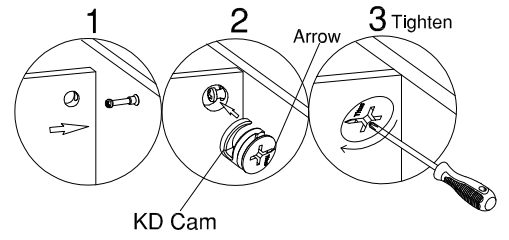

STEP 30

Prepare Panel

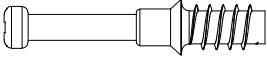
H180604  [10]
KD Bolt

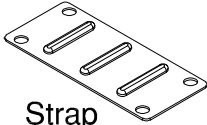
H39922  [2]
Strap

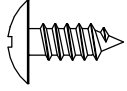
H35251  [4]
#10 x 1/2"

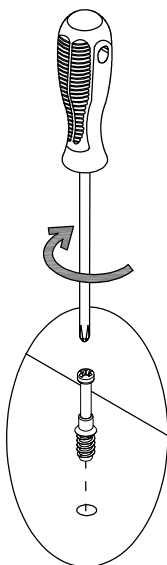
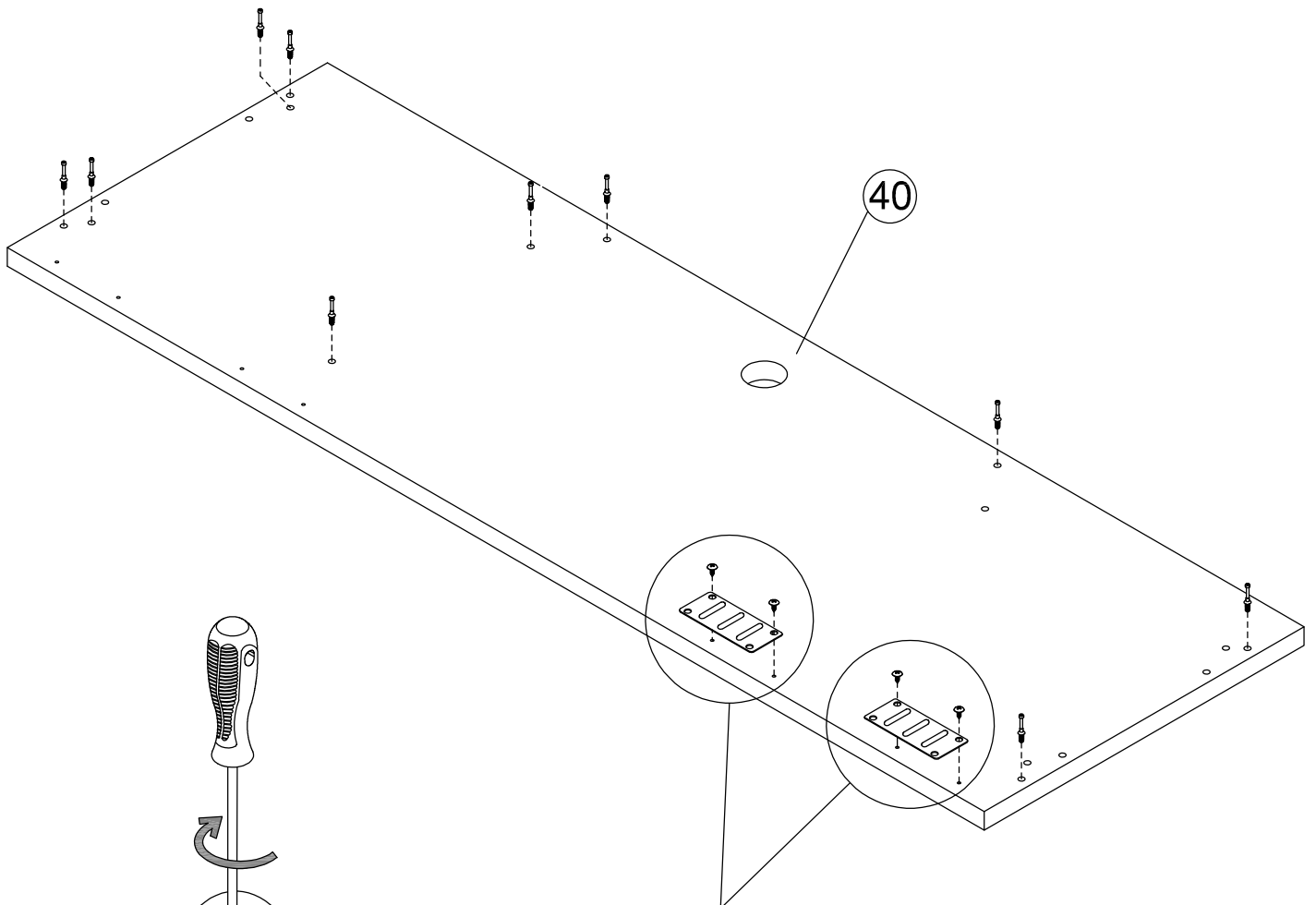

Do not fully tighten.
No apriete completamente.
Ne pas viser a fond.

STEP 31

Prepare Panels

H180604

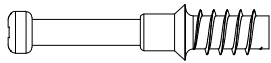

[6]

KD Bolt

H38169

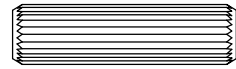

[4]

Wood Dowel
8 x 30mm

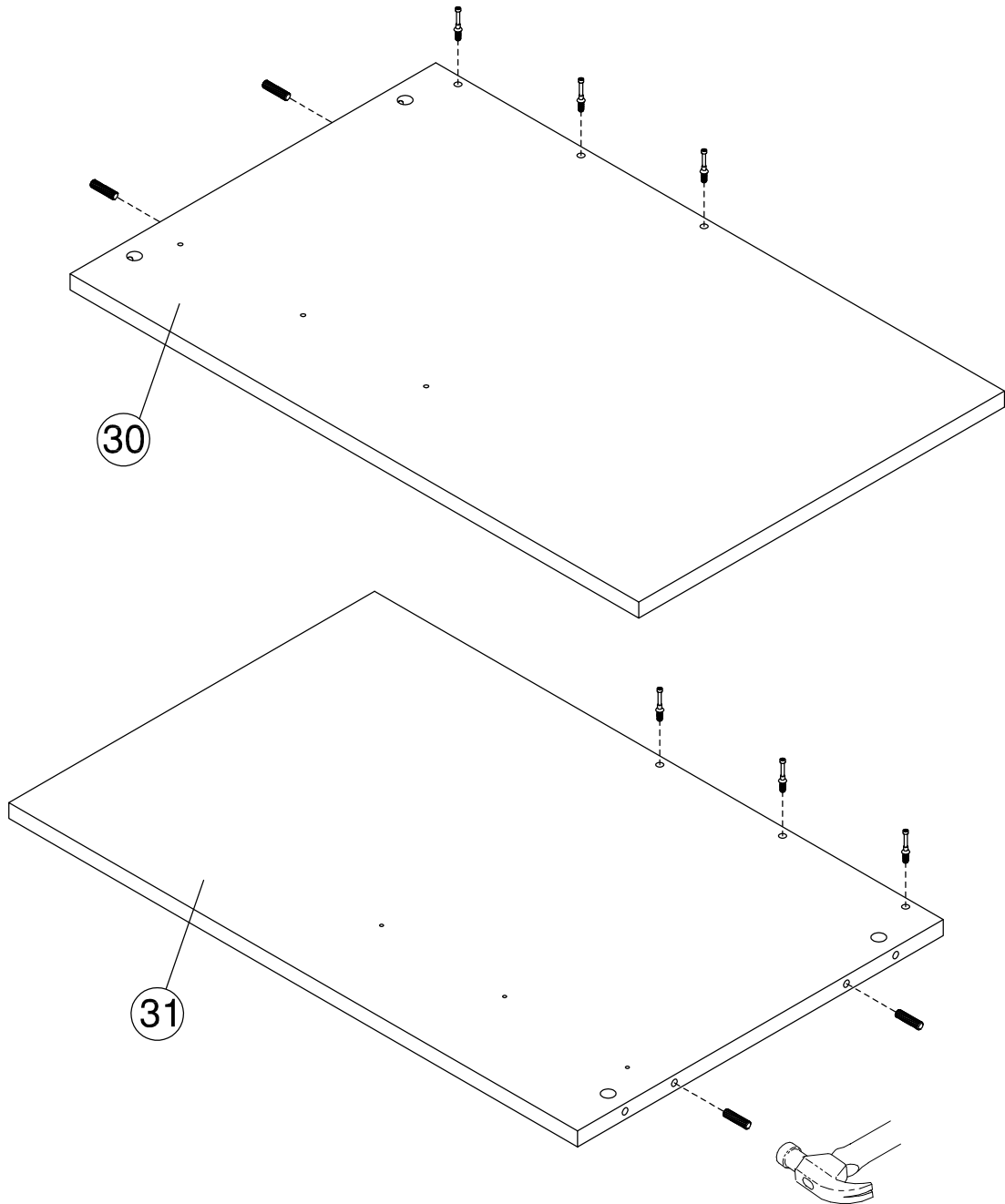
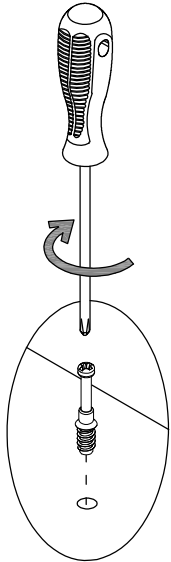

STEP 32

Assemble Panels

H181468

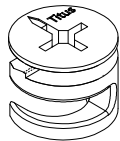

[6]

KD Cam

H170595

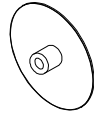

[3]

Cover Cap

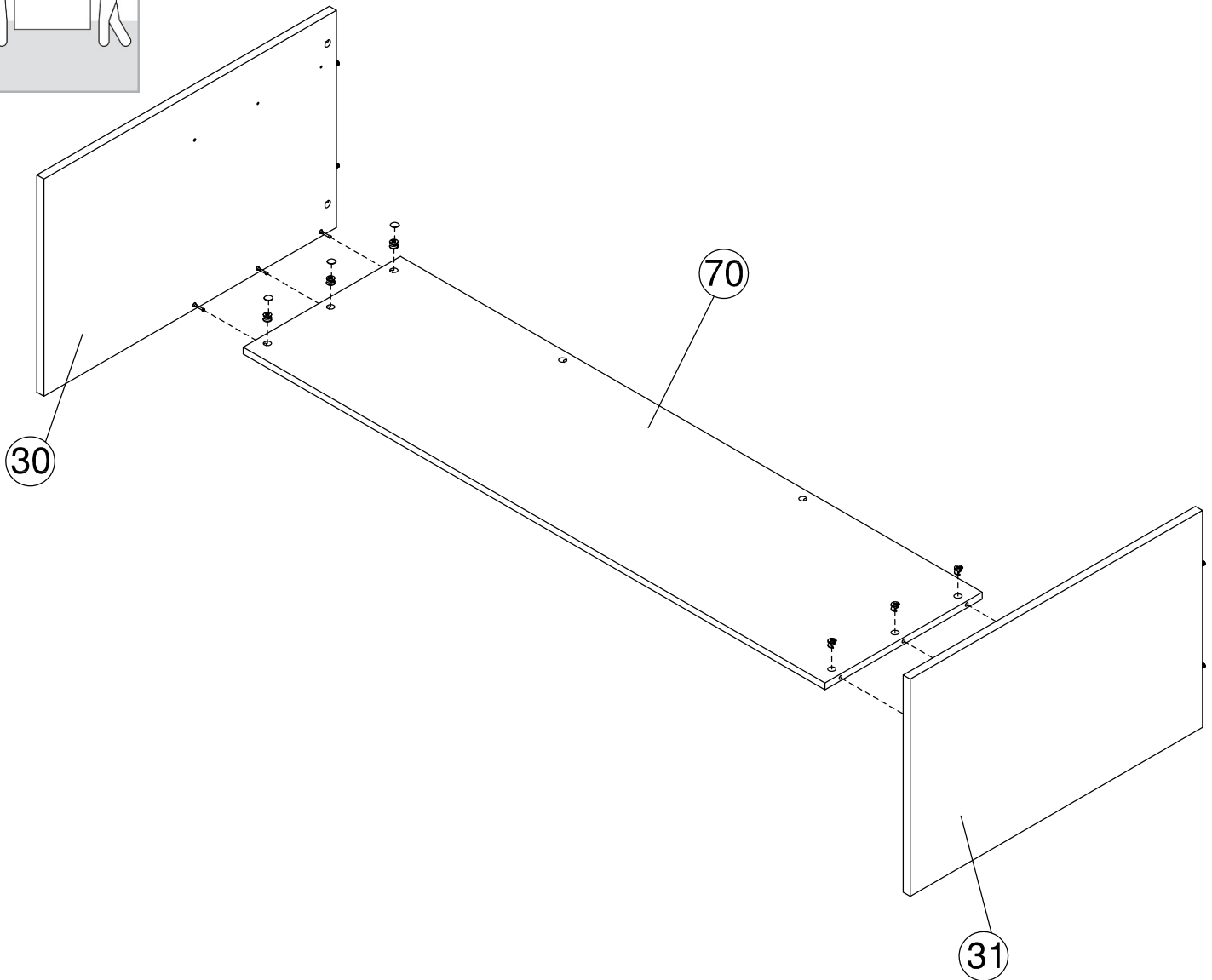
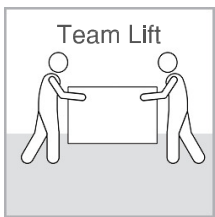
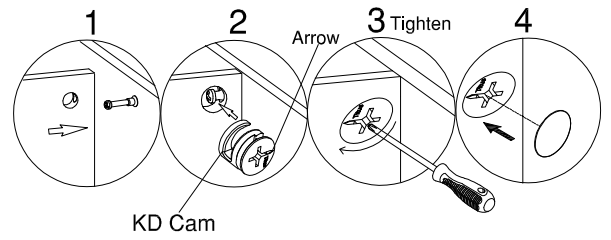

STEP 33

Assemble Panels

H181468

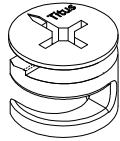

[6]

KD Cam

H170595

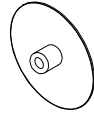

[4]

Cover Cap

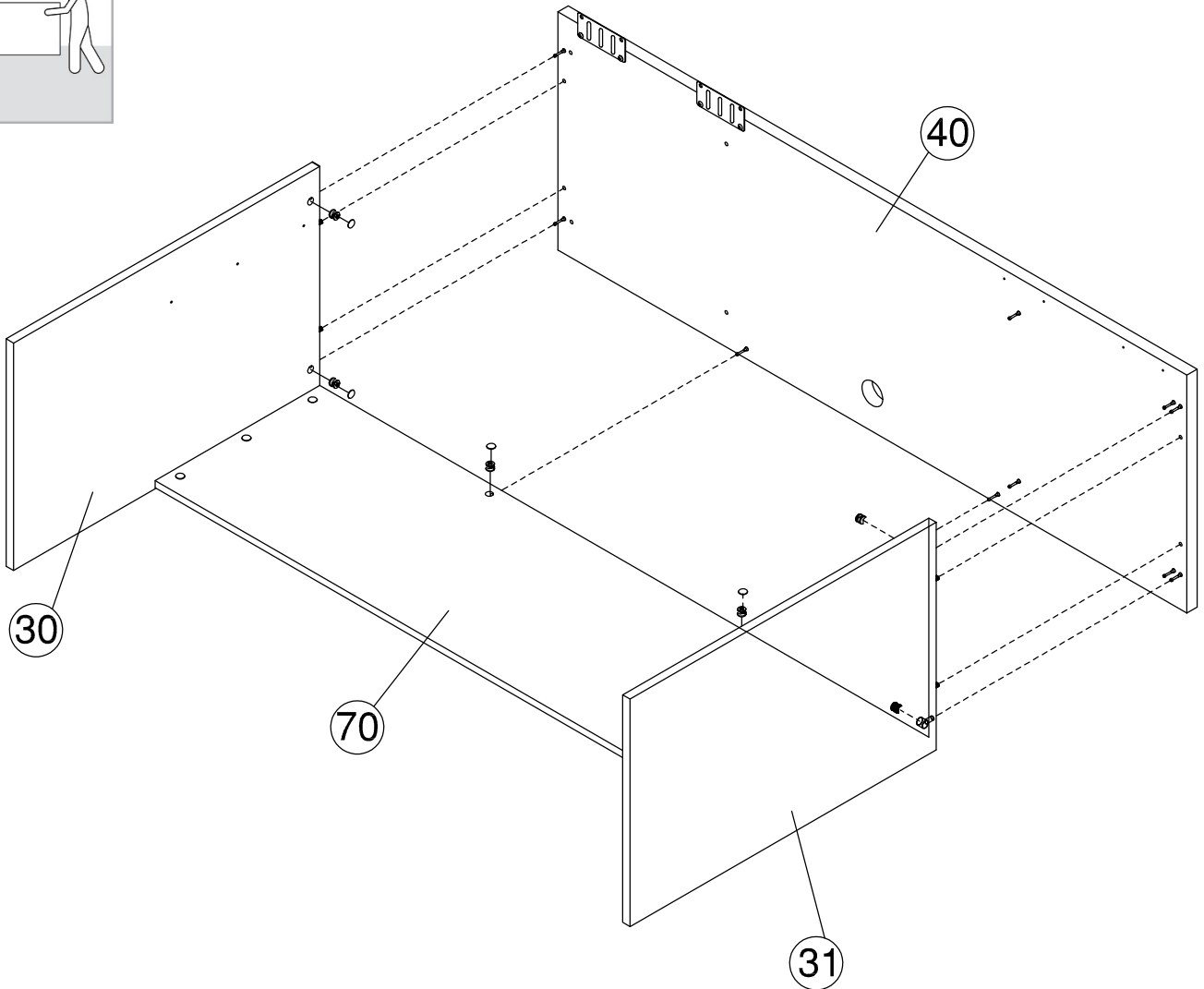
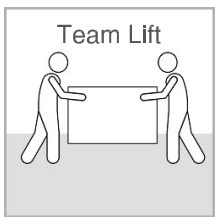
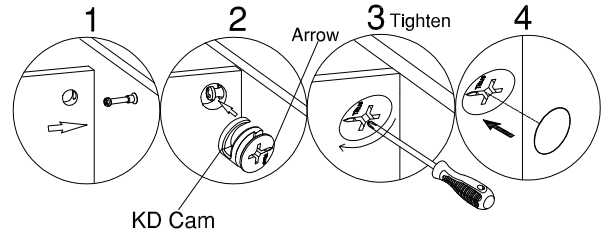

STEP 34

Assemble Panels

H181468

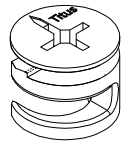

[4]

KD Cam

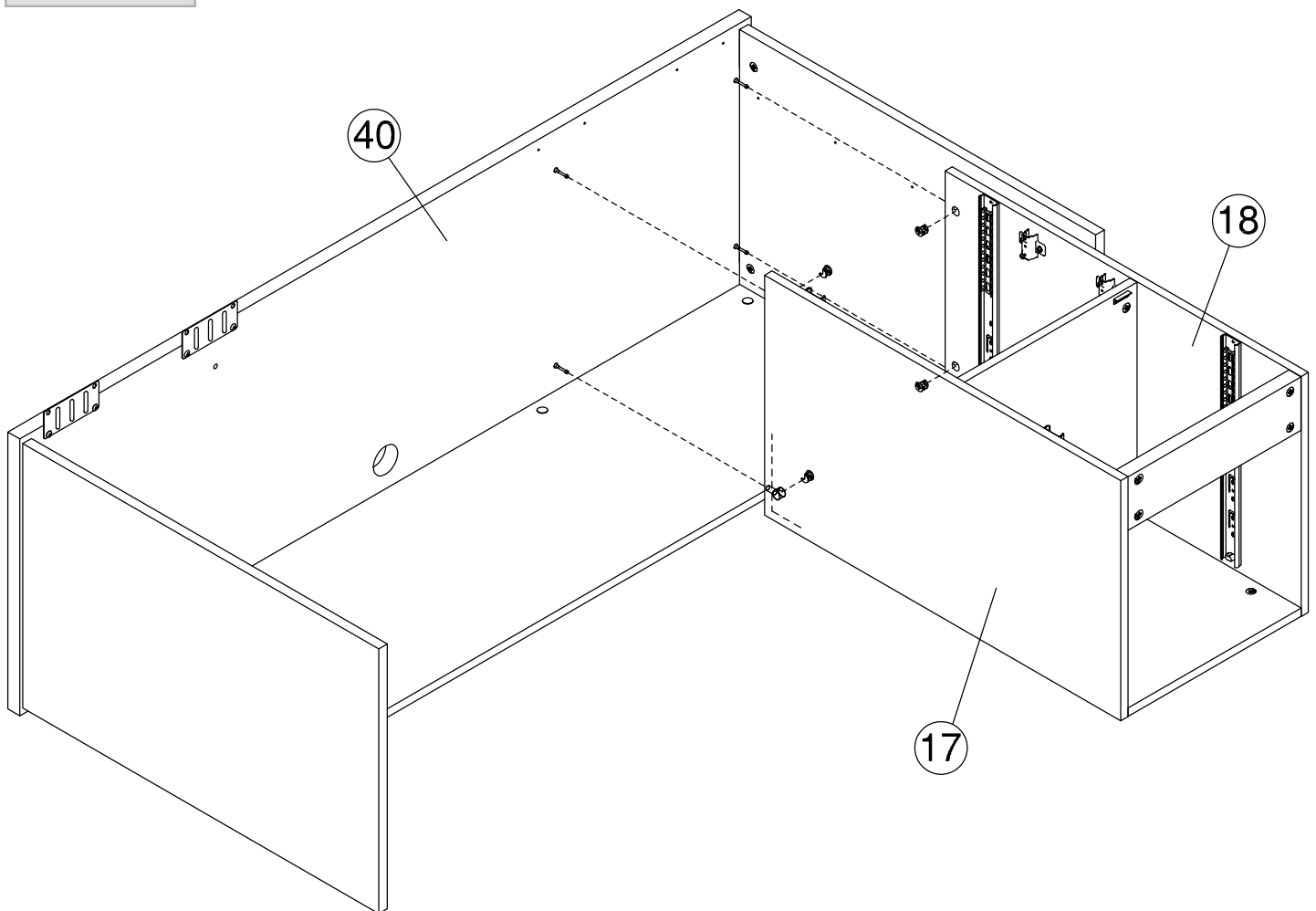
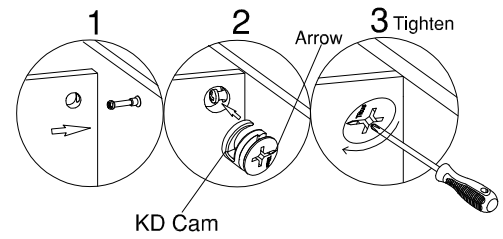

STEP 35

Prepare Panels

H180604

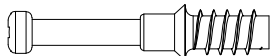

KD Bolt

[6]

H182573



Cover Cap 5mm

[3]

H38169

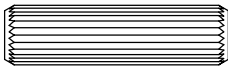

Wood Dowel
8 x 30mm

[2]

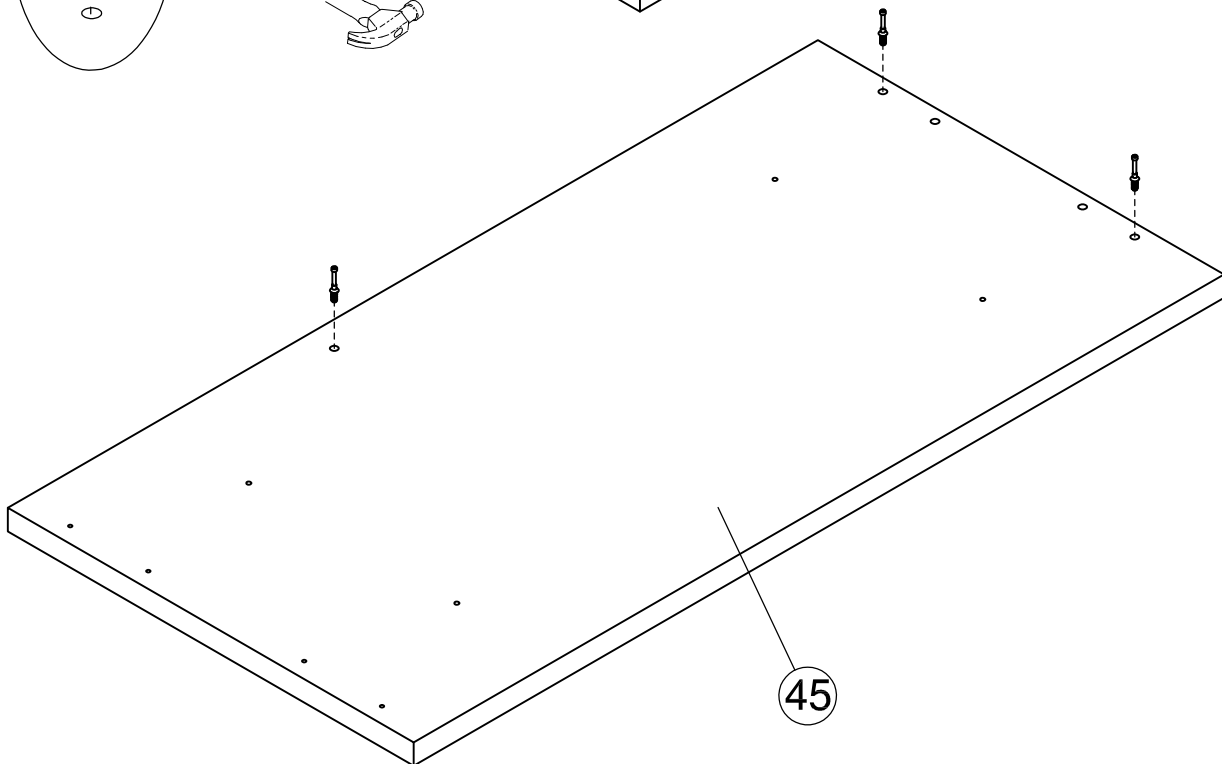
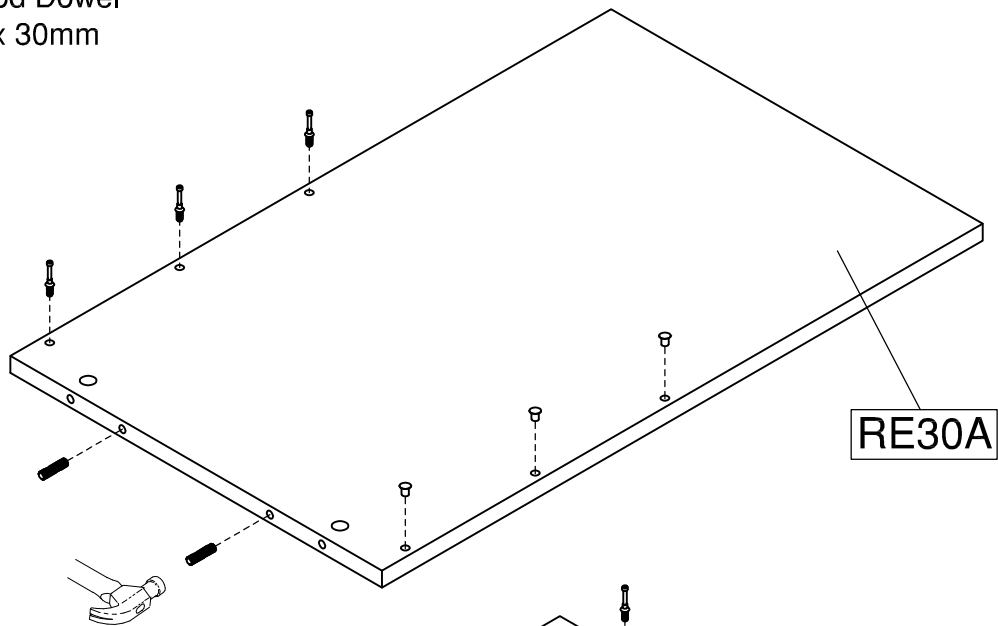
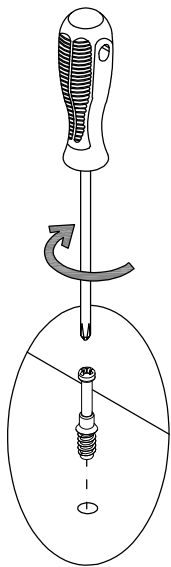

STEP 36

Assemble Panels

H181468 [3]
KD Cam

H170595 [3]
Cover Cap

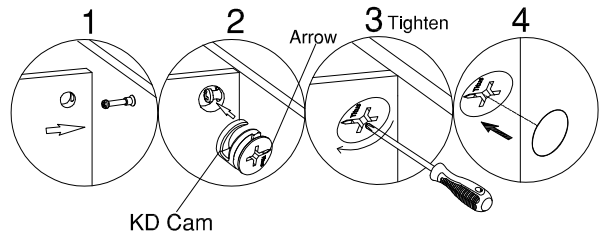

H170594 [1]
Cover Cap 15mm

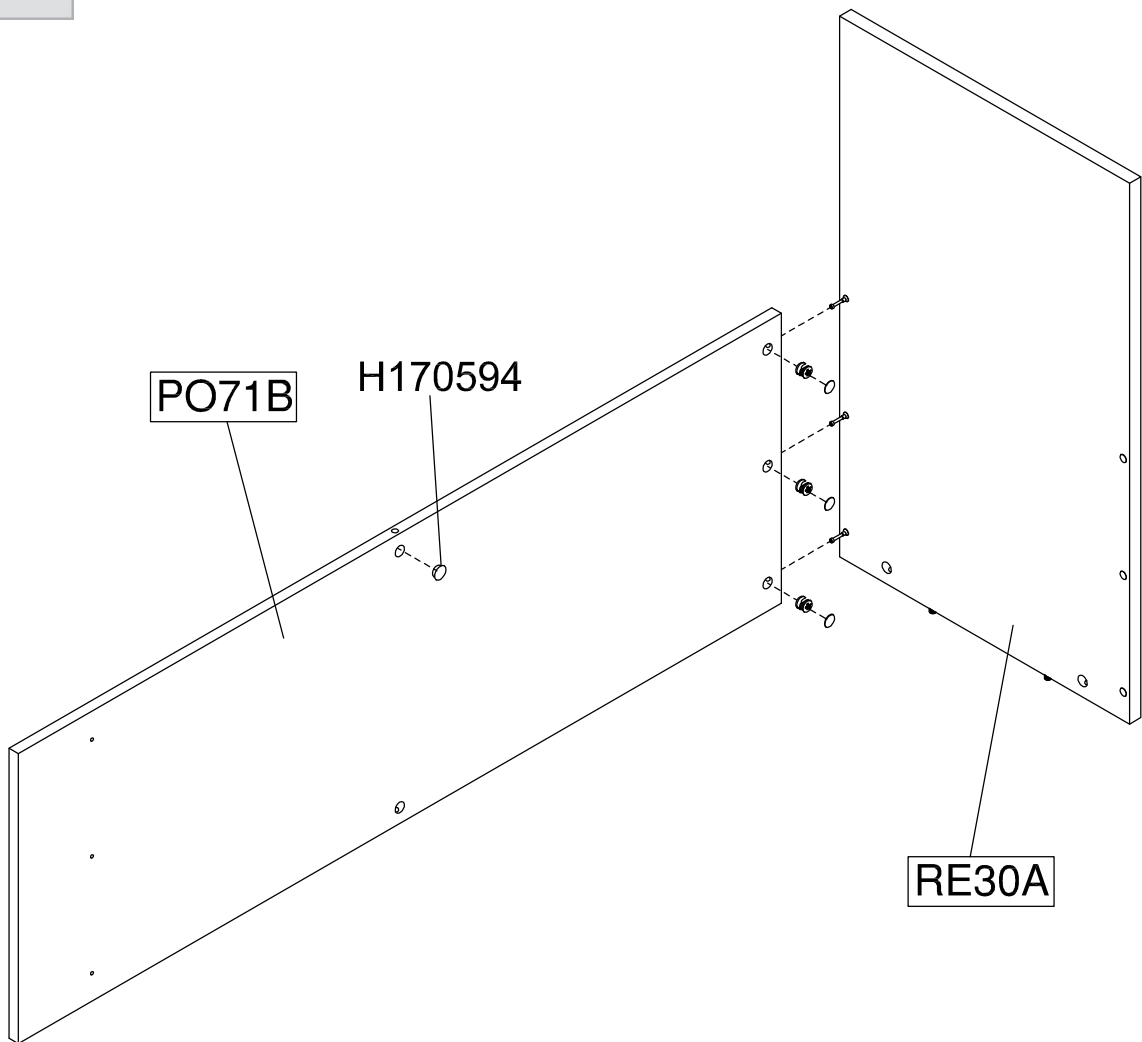
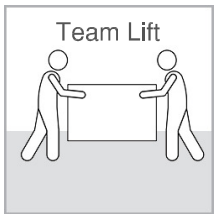

STEP 37

Assemble Panels

H181468

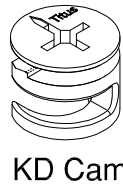

[3]

KD Cam

H170595

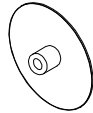

[3]

Cover Cap

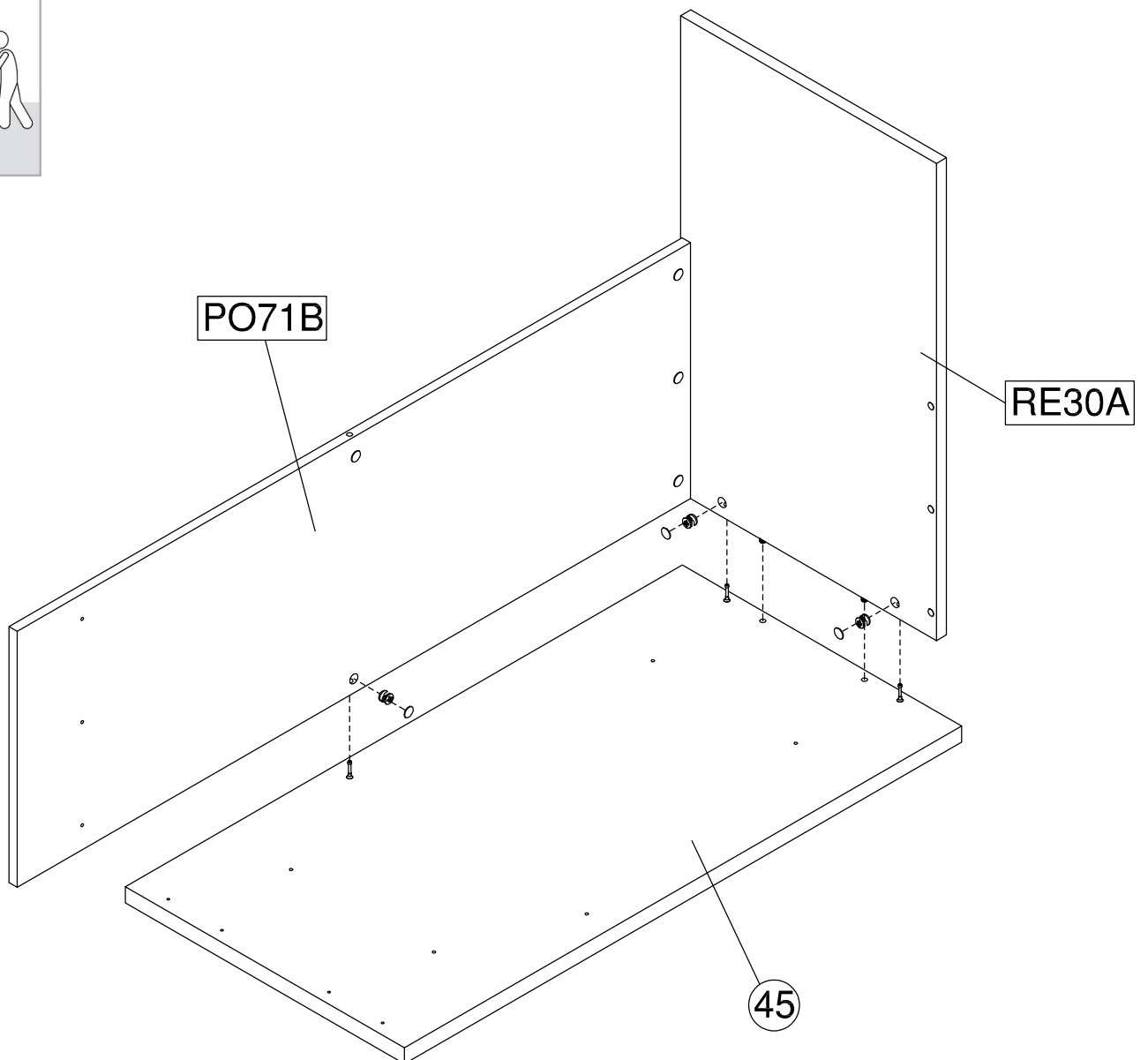
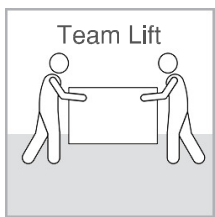
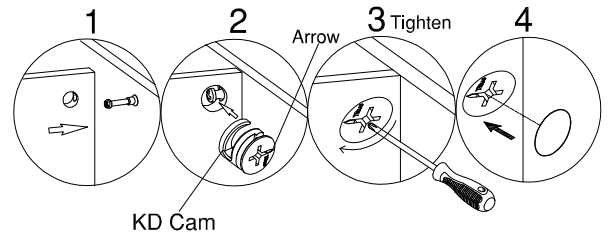

STEP 38

Assemble Panels

H175158



[4]

#12 x 9/16"

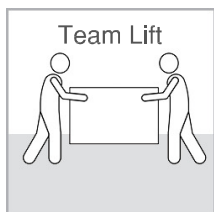

Team Lift

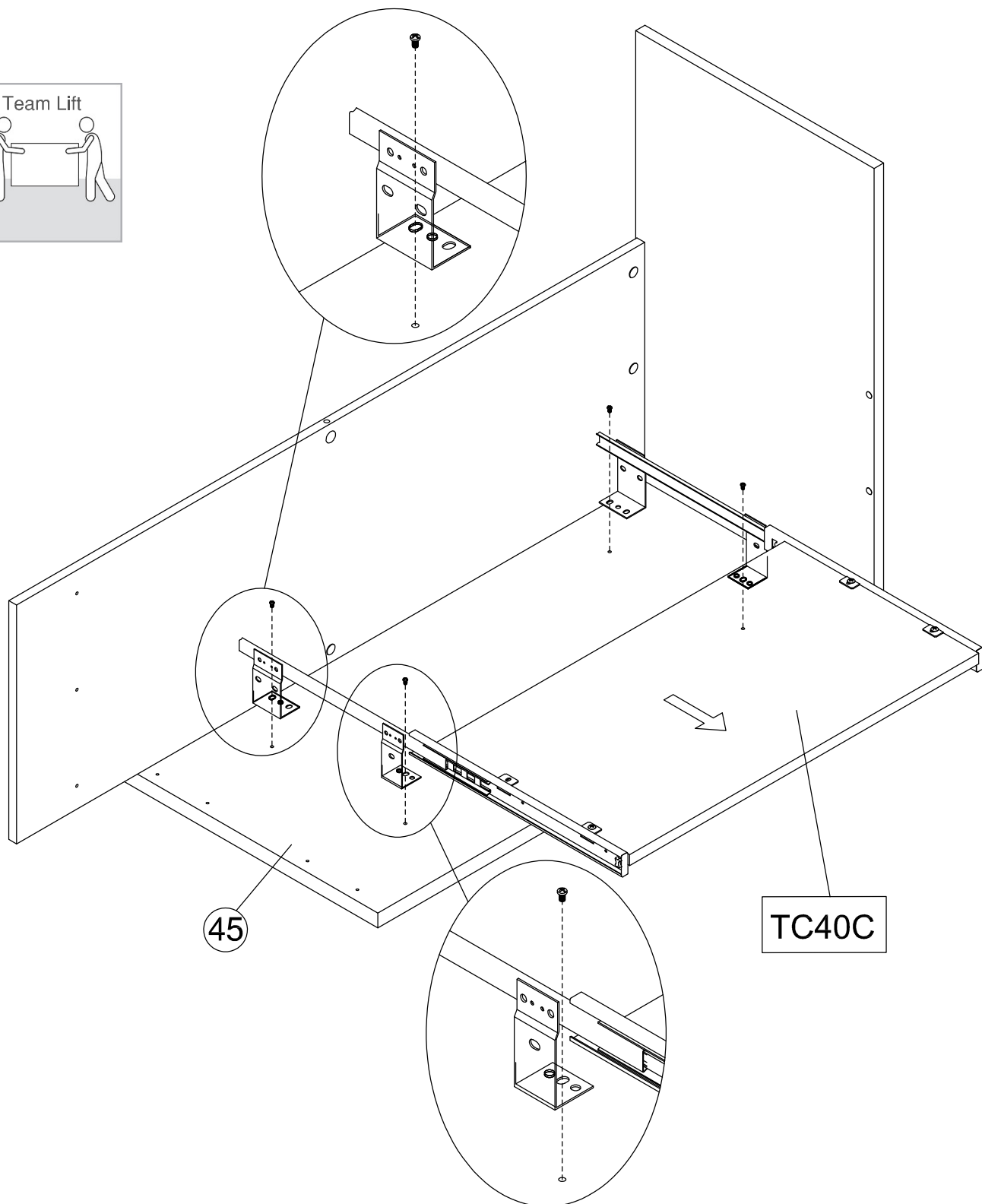

45

TC40C

STEP 39

Assemble Panels

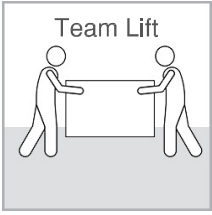

H35251 [4]
#10 x 1/2"

H150019 [3]
#8 x 1"

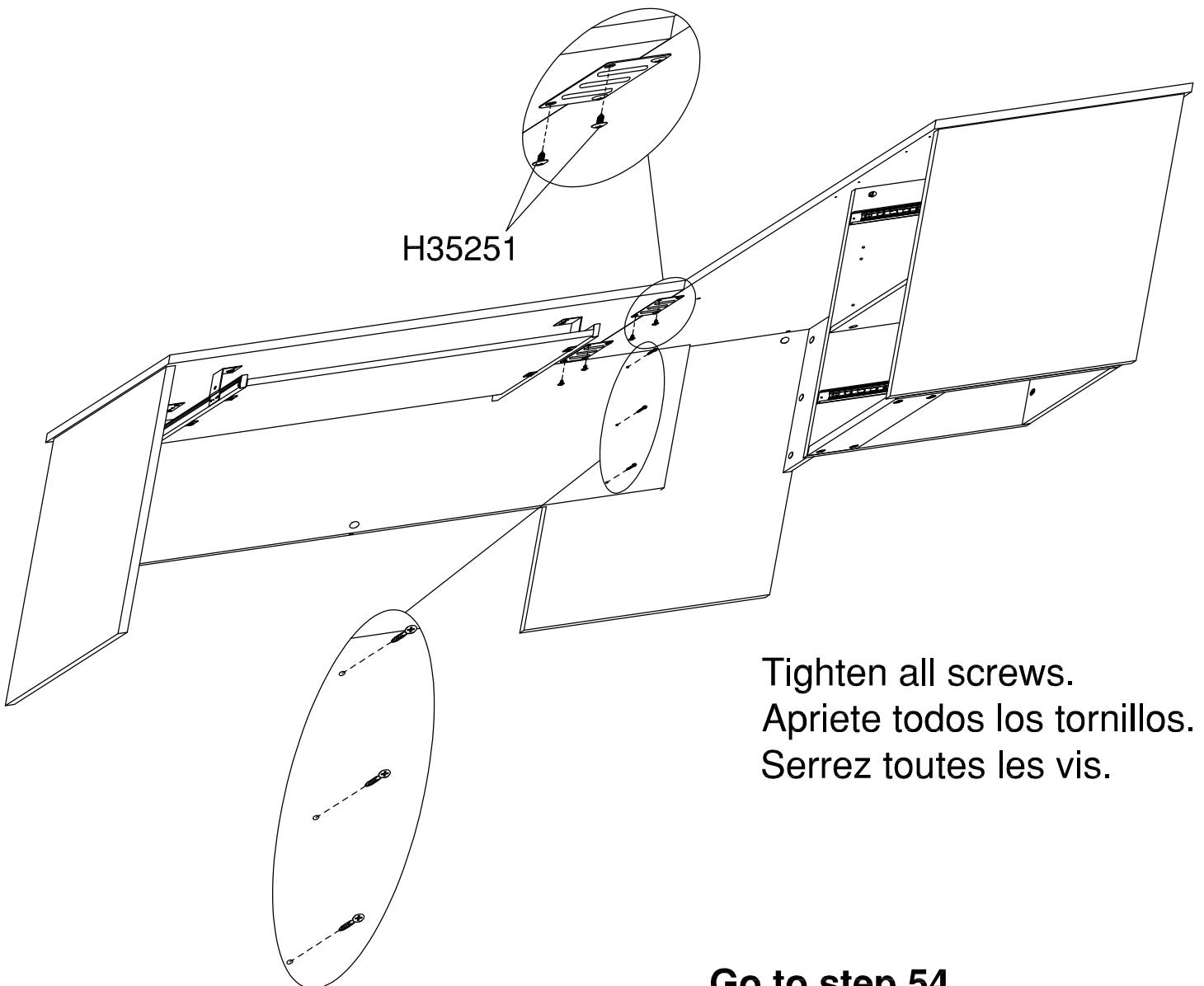

Tighten all screws.
Apriete todos los tornillos.
Serrez toutes les vis.

Go to step 54
Proceda al paso 54
Allez a l'etape 54

STEP 40

Prepare Panel

H101725

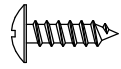

[6]

#6 x 1/2"

H180604



[6]

KD Bolt

H201027

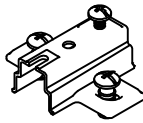

[2]

Mounting Plate

H167909

3

[2]

16" Slide Mount

Orientation
Orientación
L'orientation

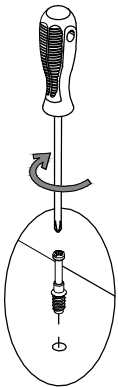
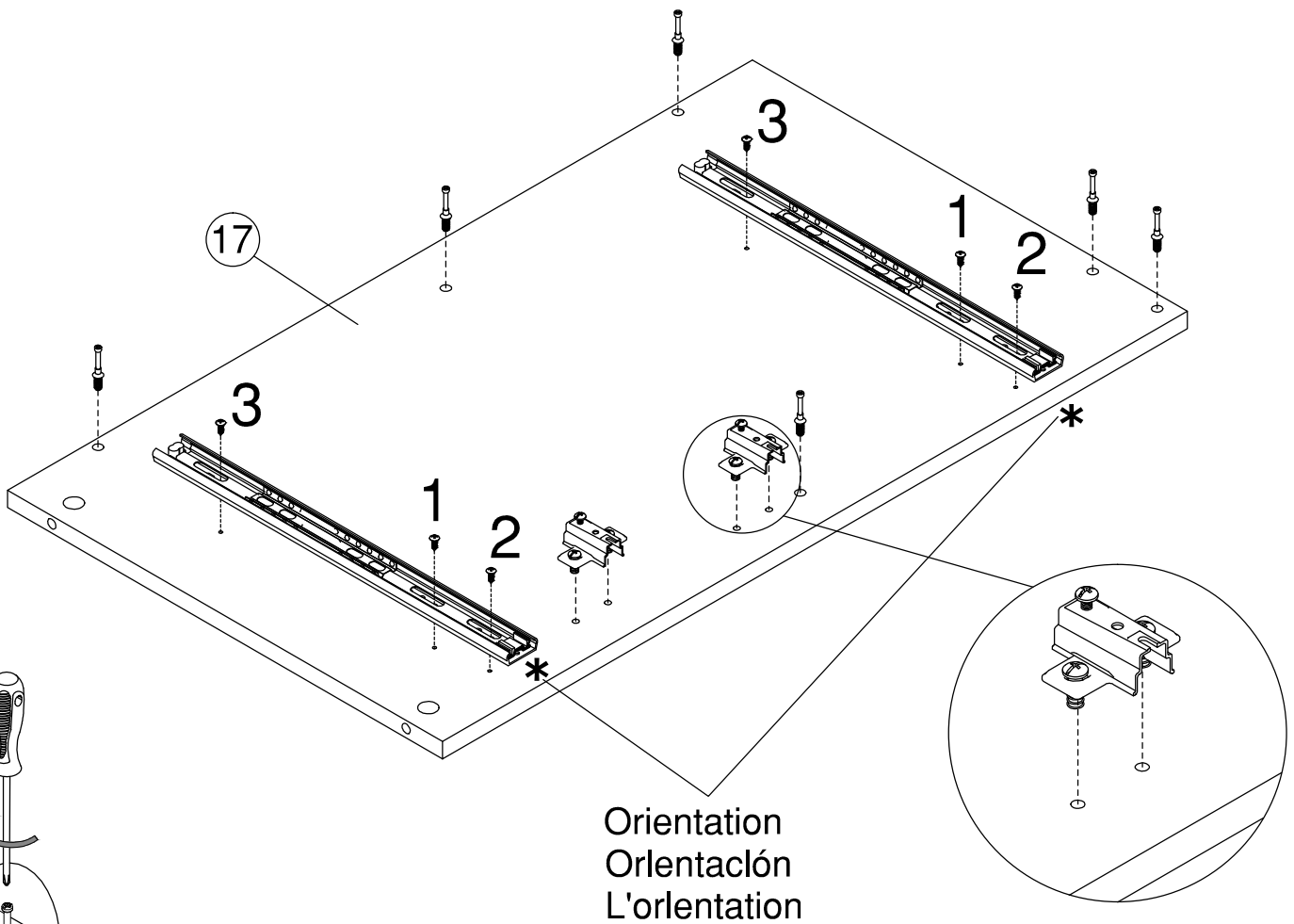

STEP 41

Prepare Panel

H182573  [4]
Cover Cap 5mm

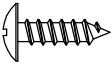
H101725  [6]
#6 x 1/2"

H180604  [6]
KD Bolt

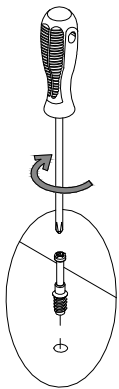
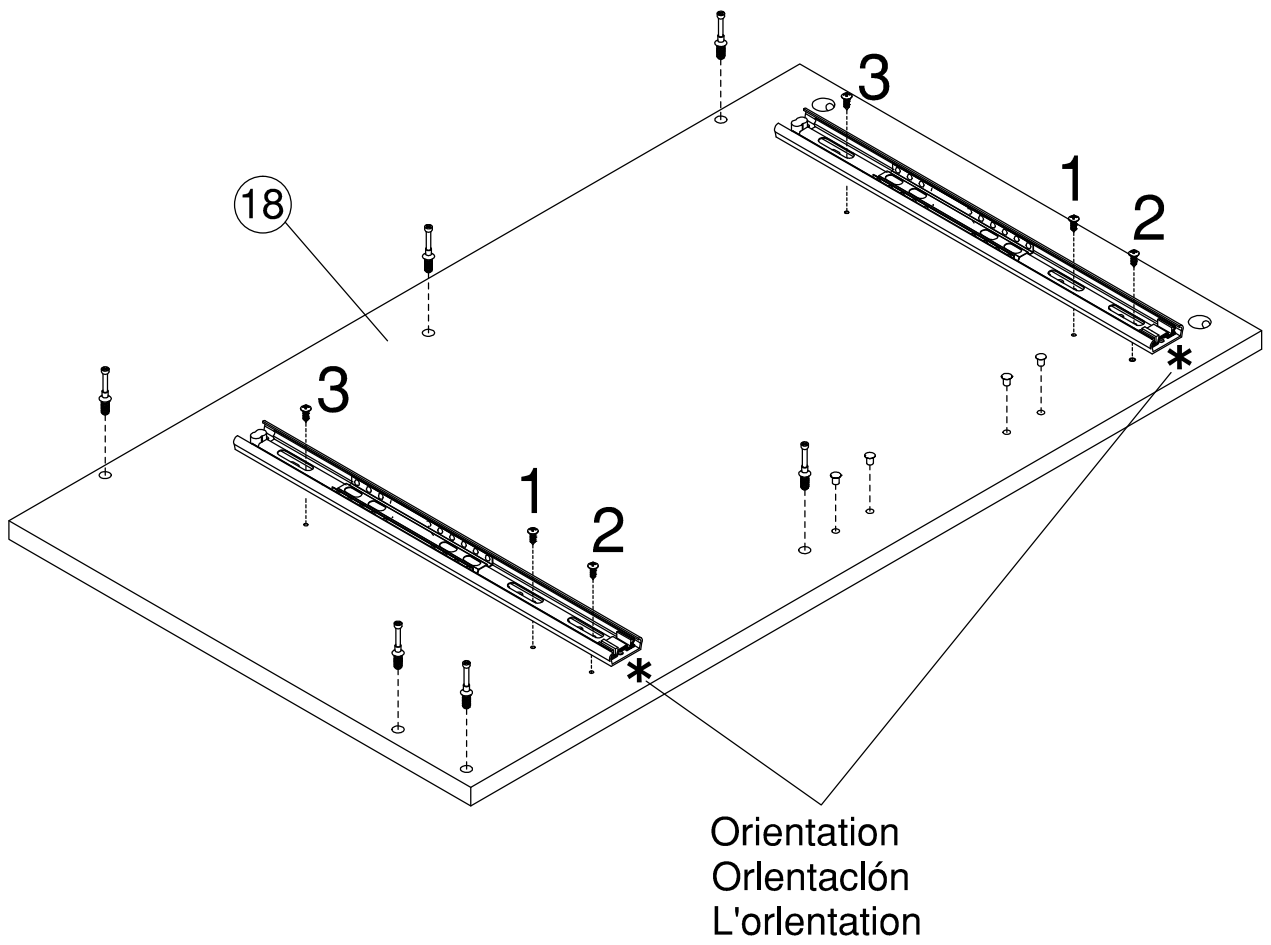
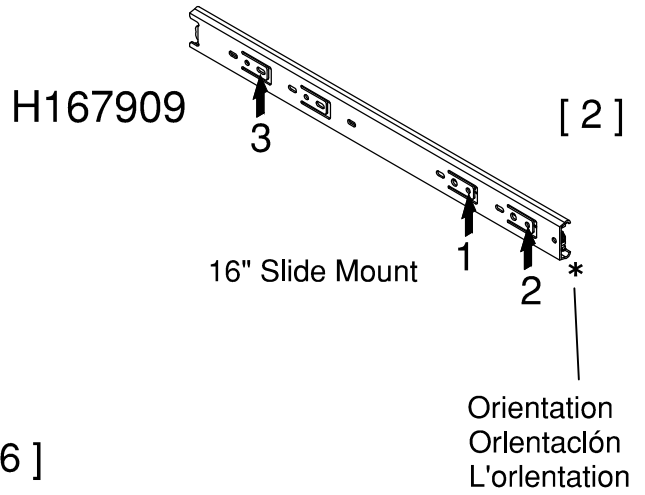

STEP 42

Prepare Panel

H153243



[2]

#5x9/16"

H199615

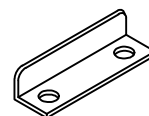

[1]

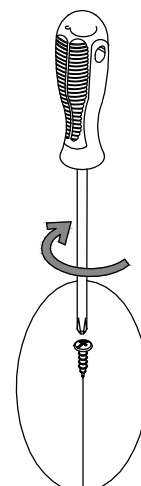
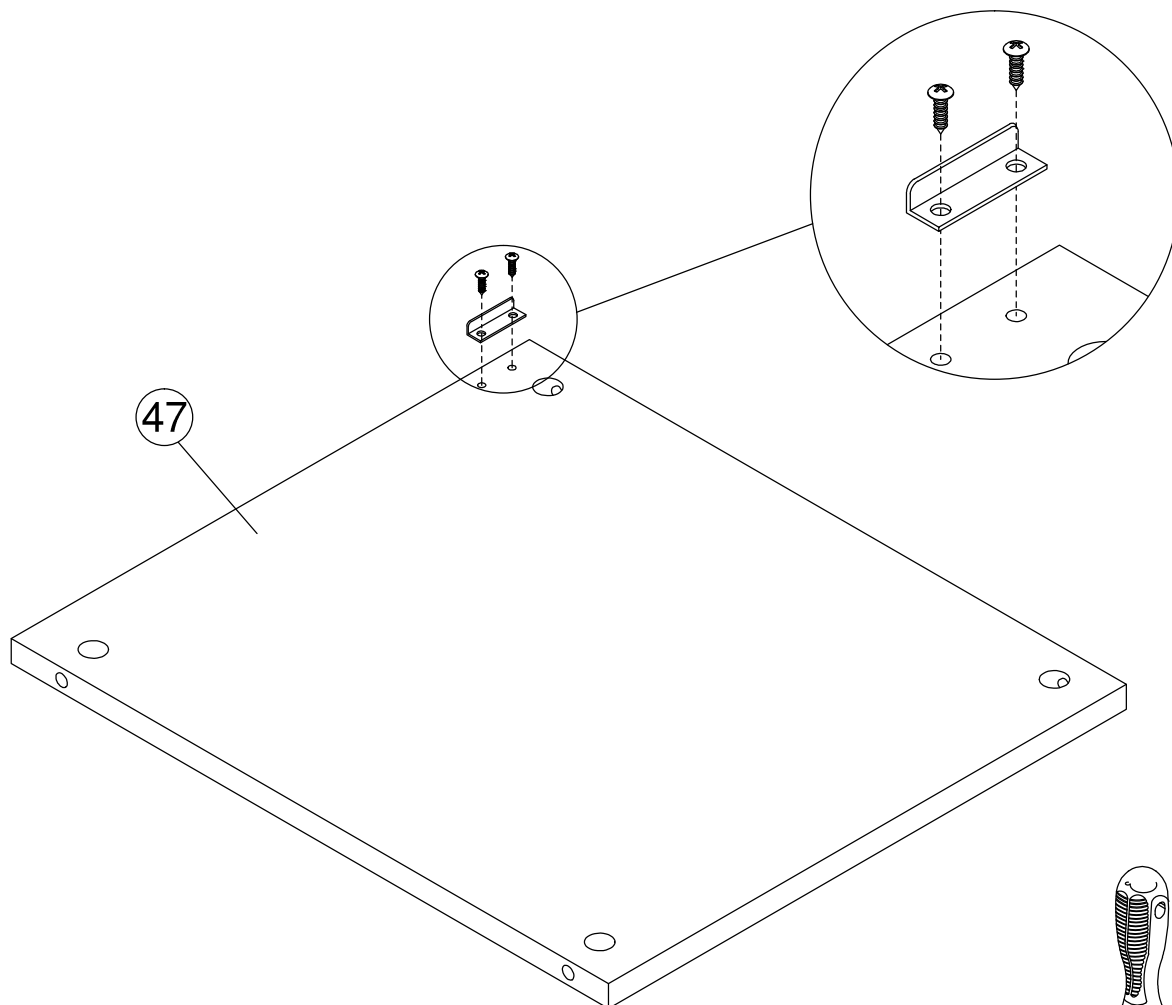

STEP 43

Assemble Panels

H181468

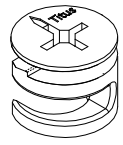

[6]

KD Cam

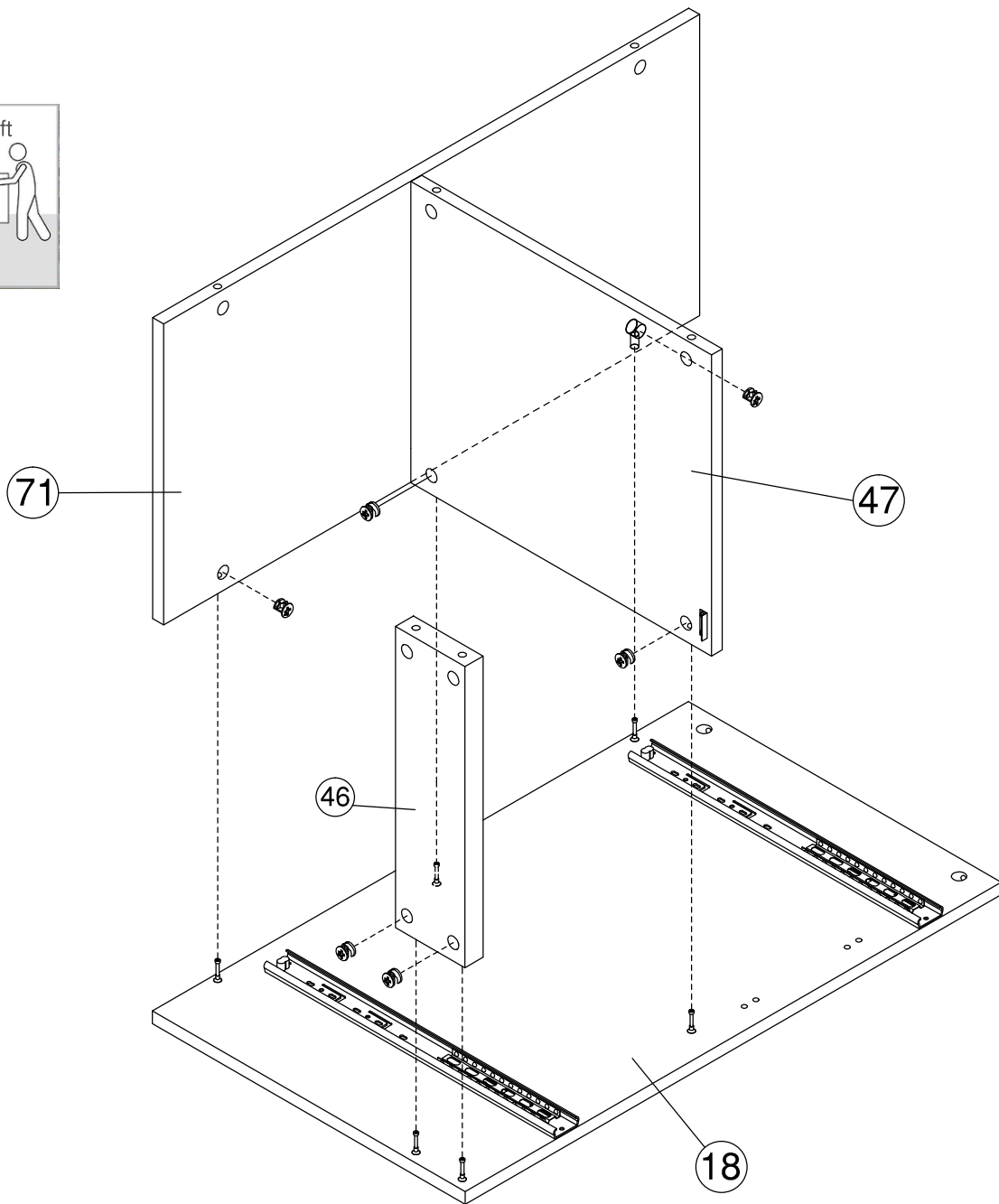
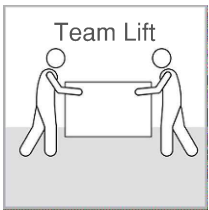
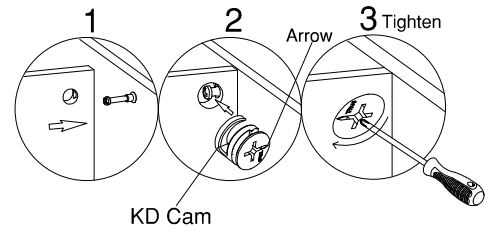

STEP 44

Assemble Panels

H181468

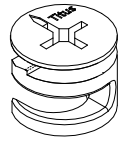

[6]

KD Cam

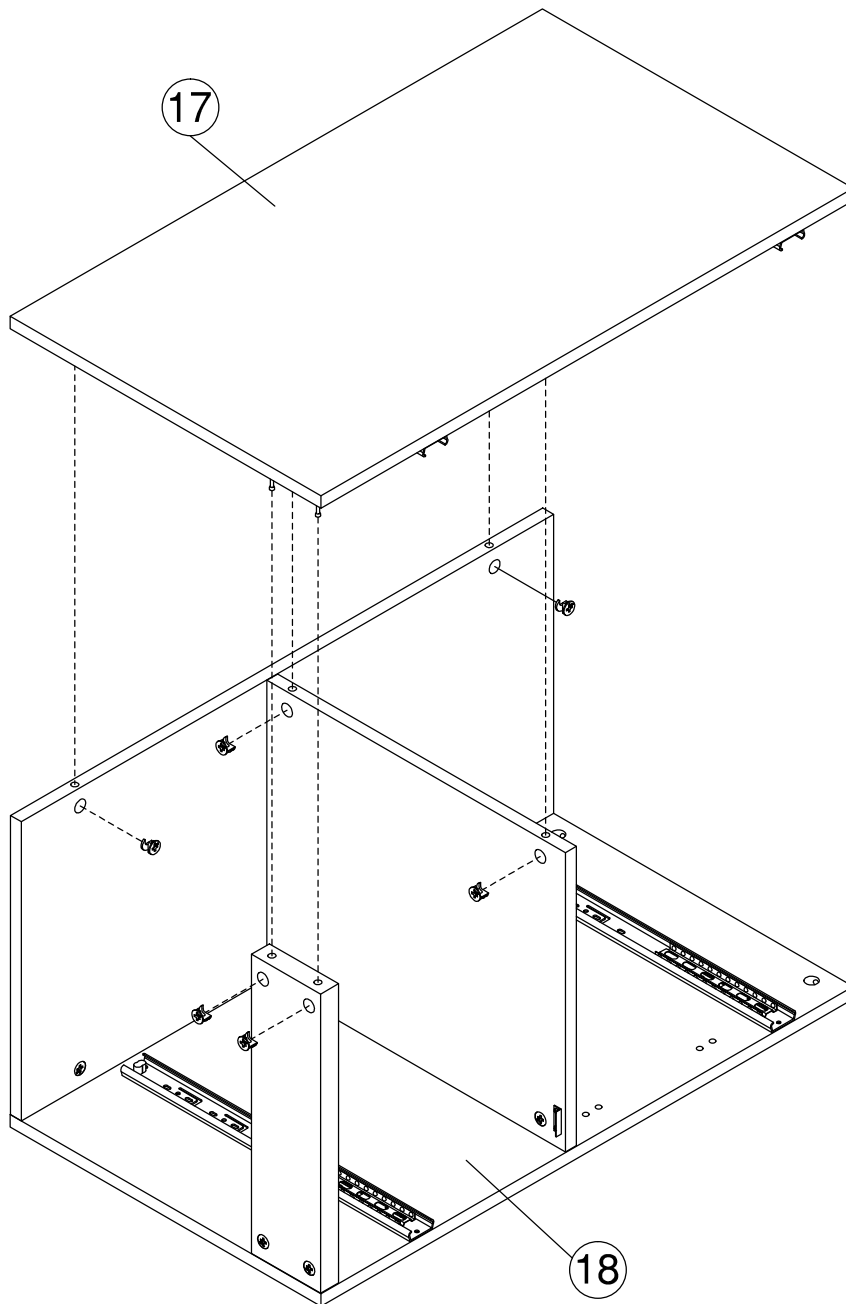
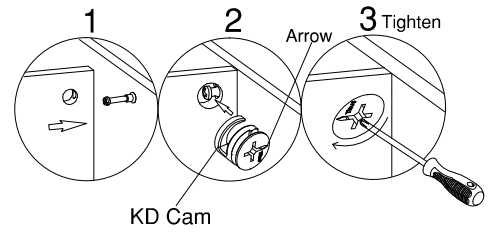

STEP 45

Prepare Panel

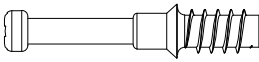
H180604  [10]
KD Bolt

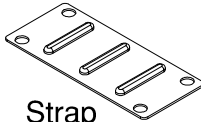
H39922  [2]
Strap

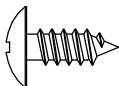
H35251  [4]
#10 x 1/2"

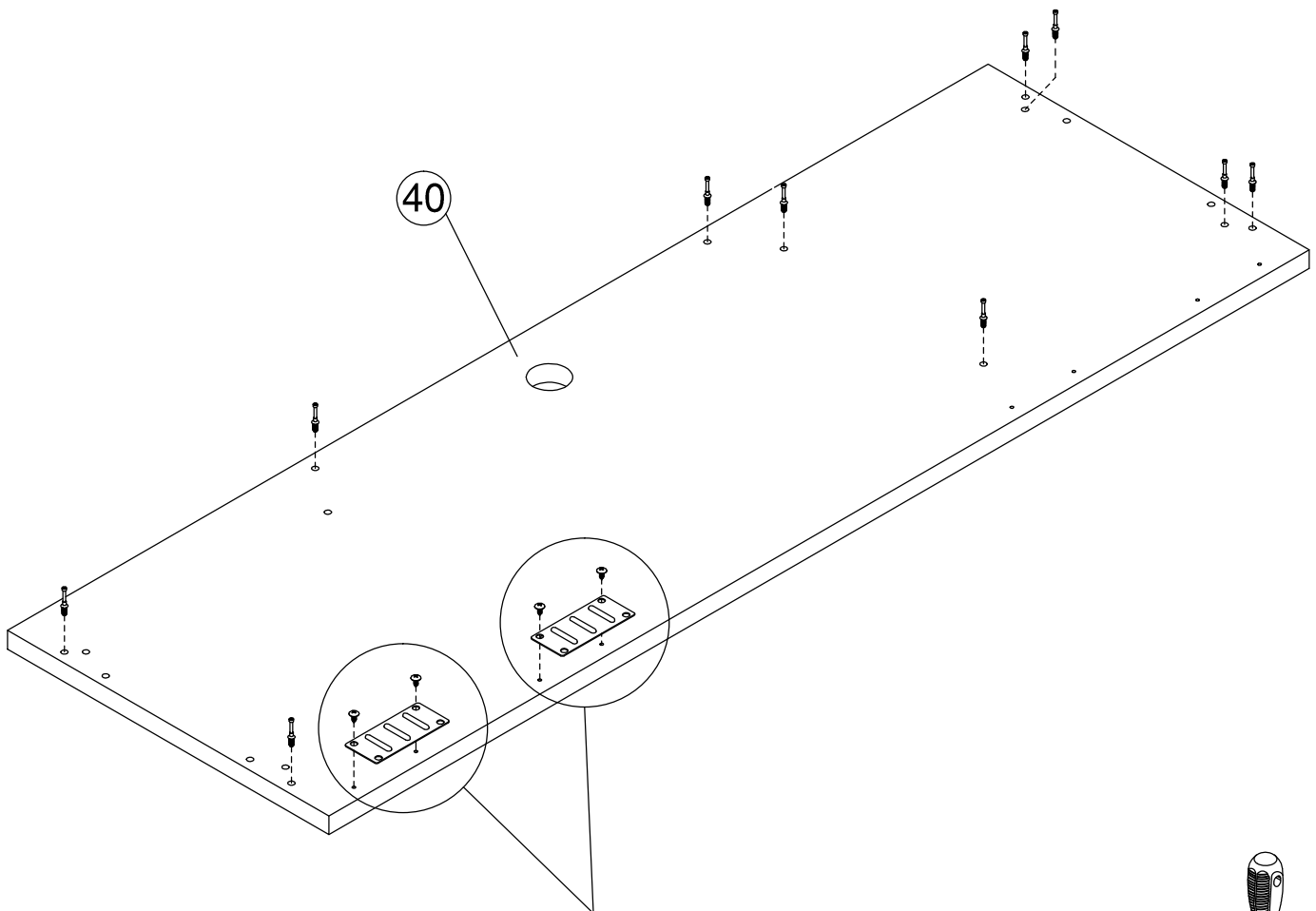

Do not fully tighten.
No apriete completamente.
Ne pas viser a fond.

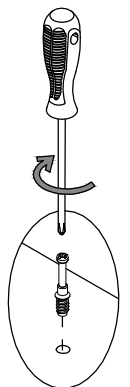

STEP 46

Prepare Panels

H180604

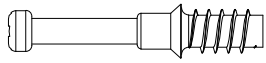

KD Bolt

[6]

H38169

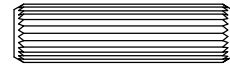

Wood Dowel
8 x 30mm

[4]

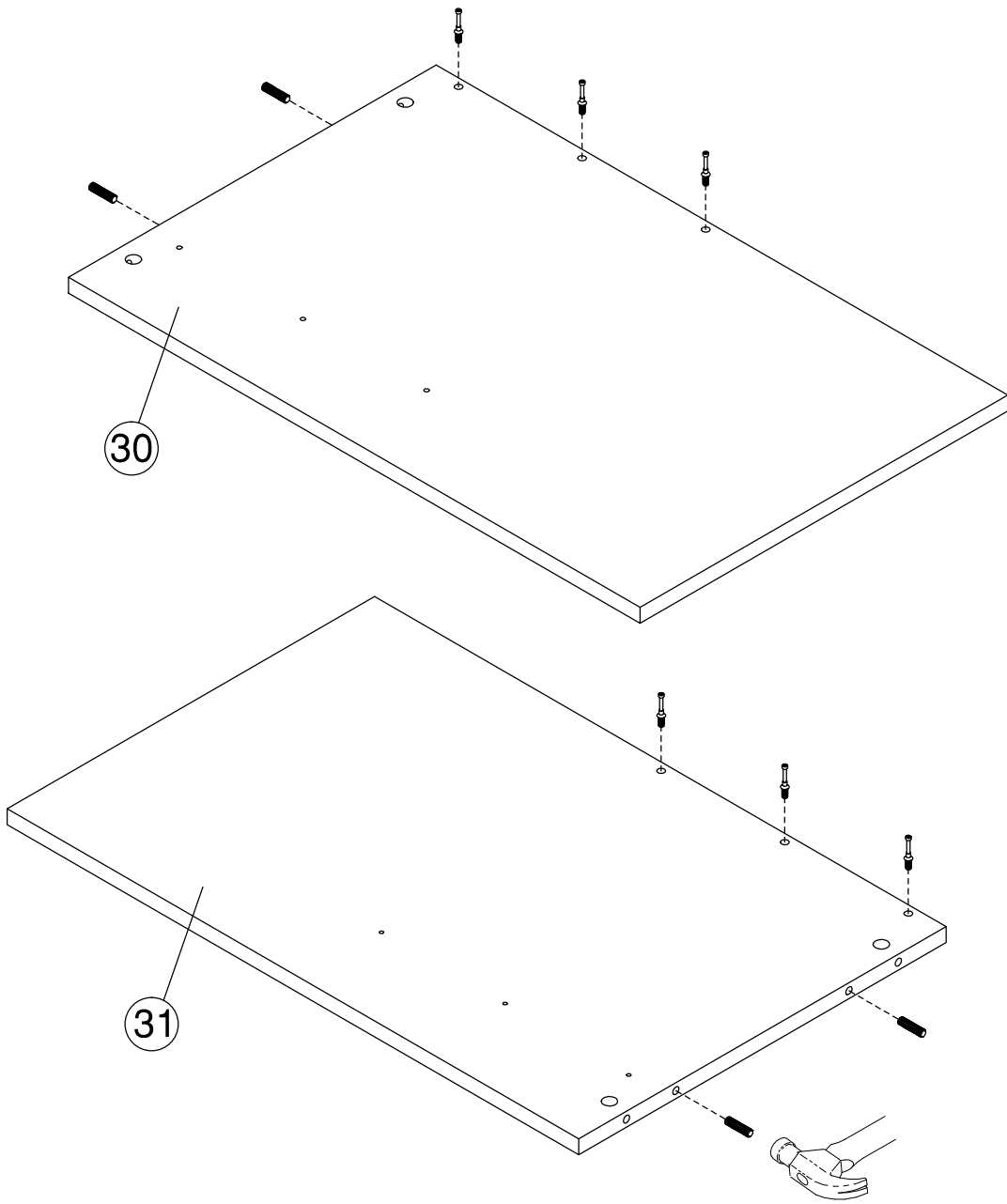
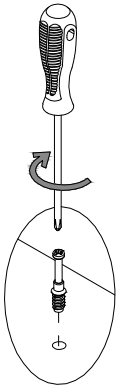

STEP 47

Assemble Panels

H181468

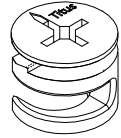

[6]

KD Cam

H170595

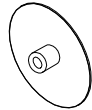

[3]

Cover Cap

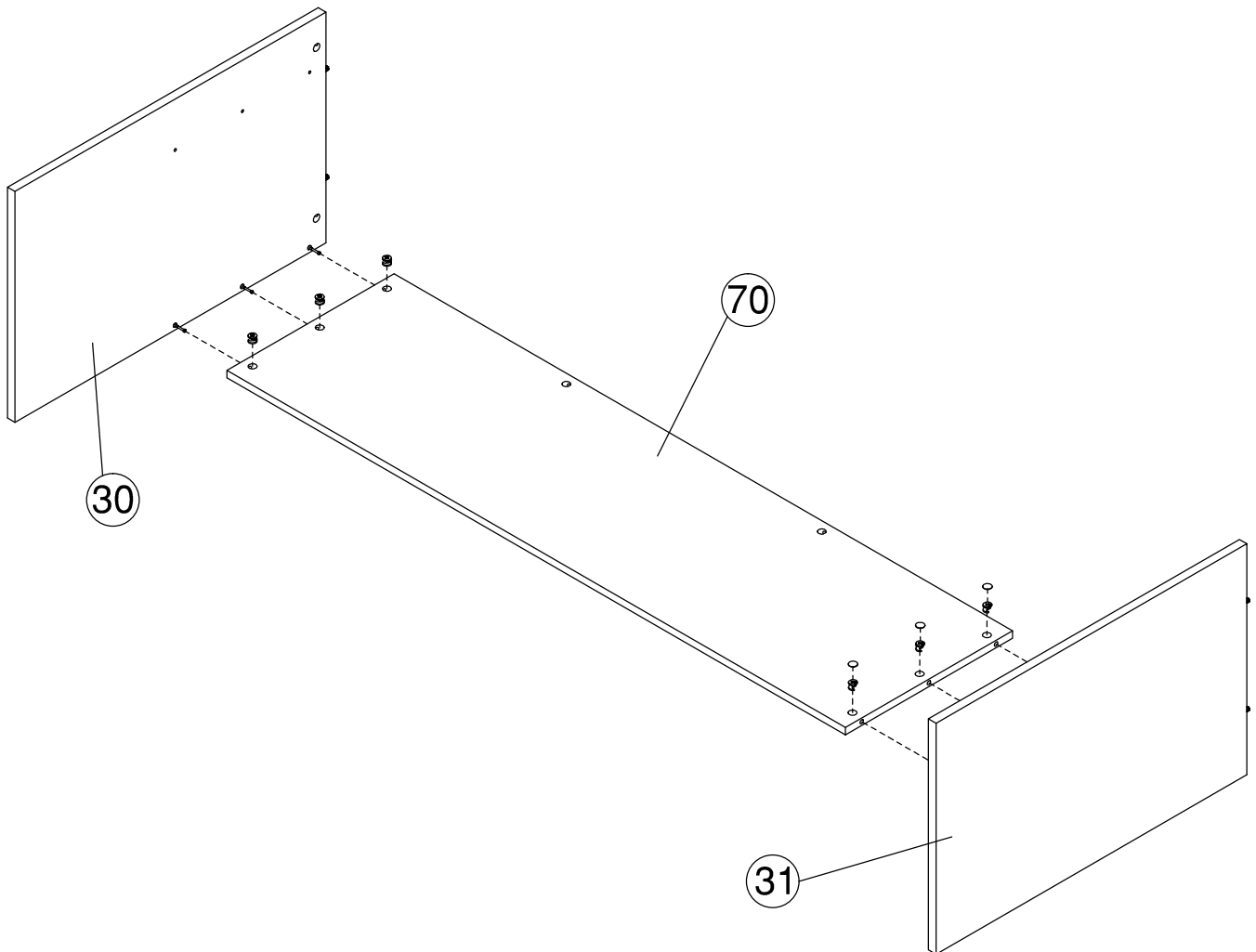
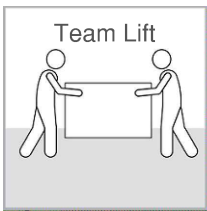
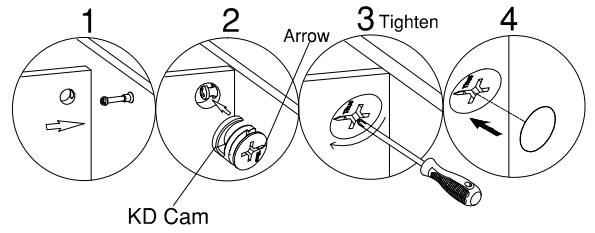

STEP 48

Assemble Panels

H181468 [6]
KD Cam

H170595 [4]
Cover Cap

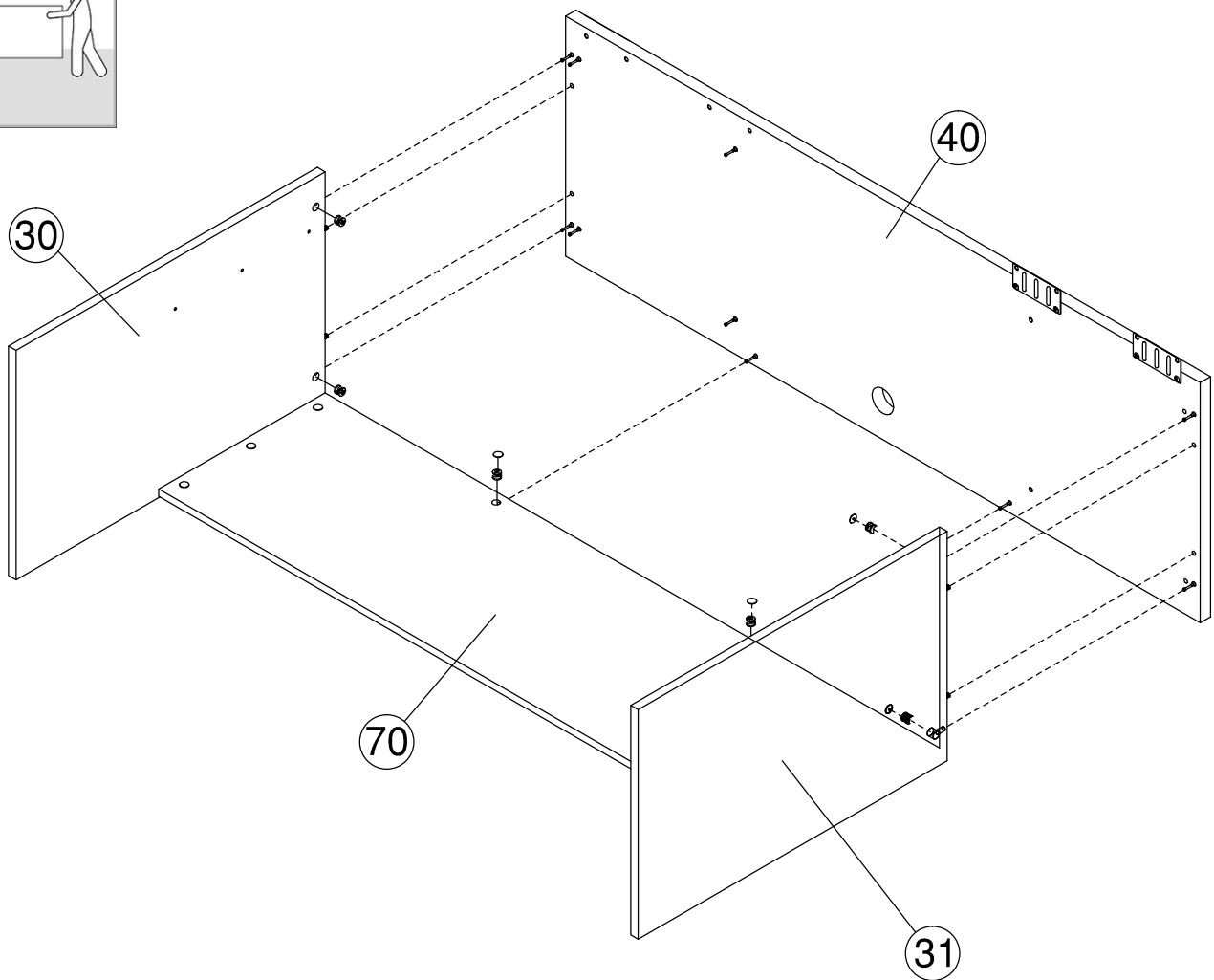
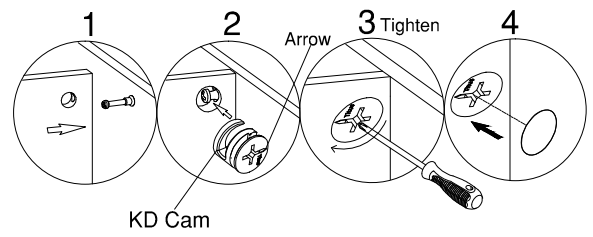

STEP 49

Assemble Panels

H181468

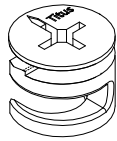

[4]

KD Cam

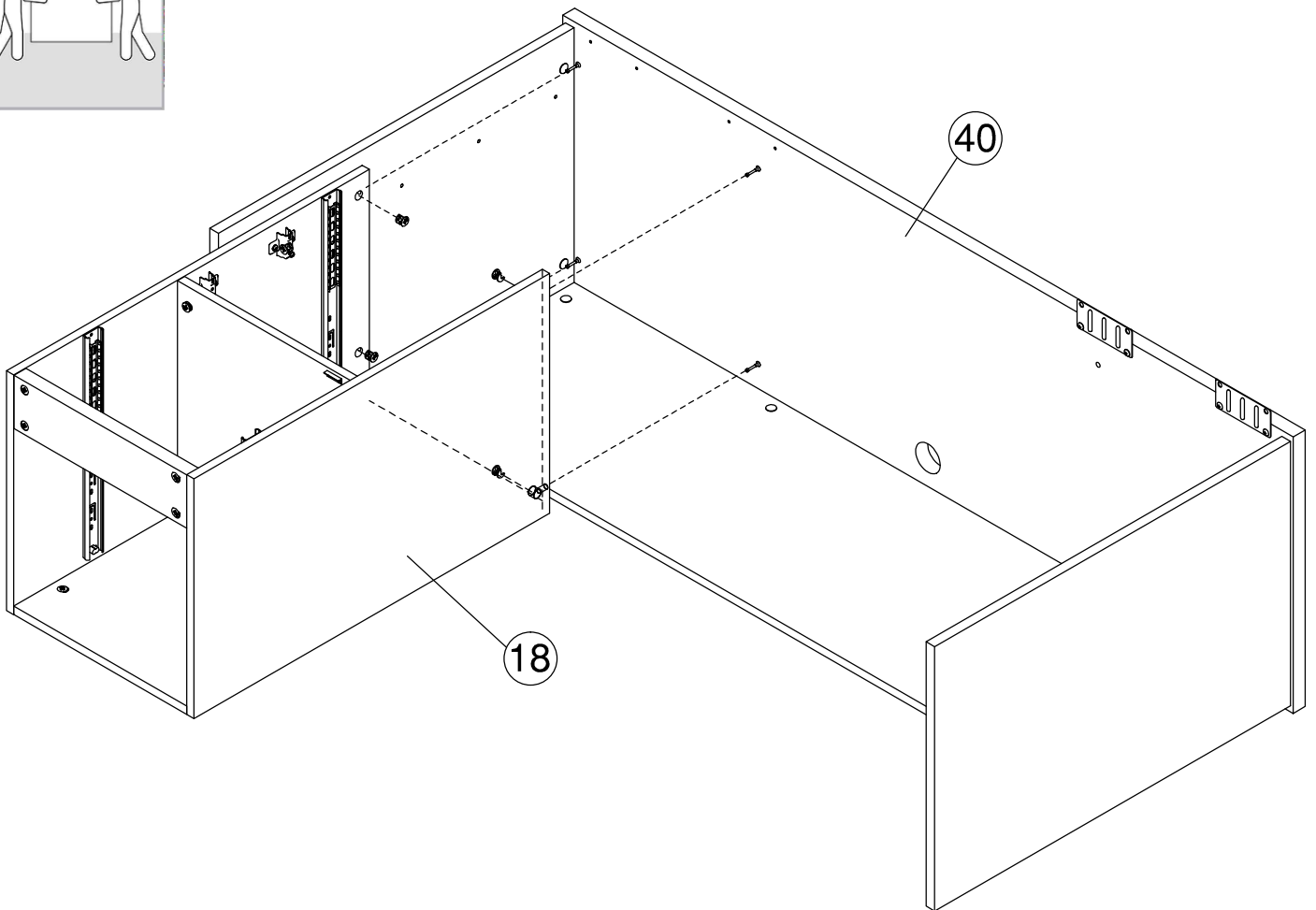
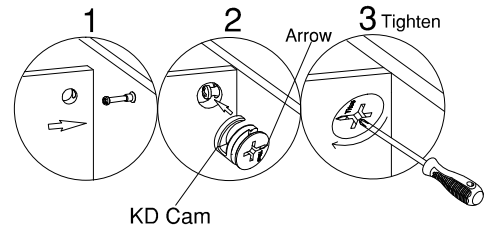

STEP 50

Prepare Panels

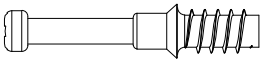
H180604  [6]
KD Bolt

H182573  [3]
Cover Cap 5mm

H38169  [2]
Wood Dowel
8 x 30mm

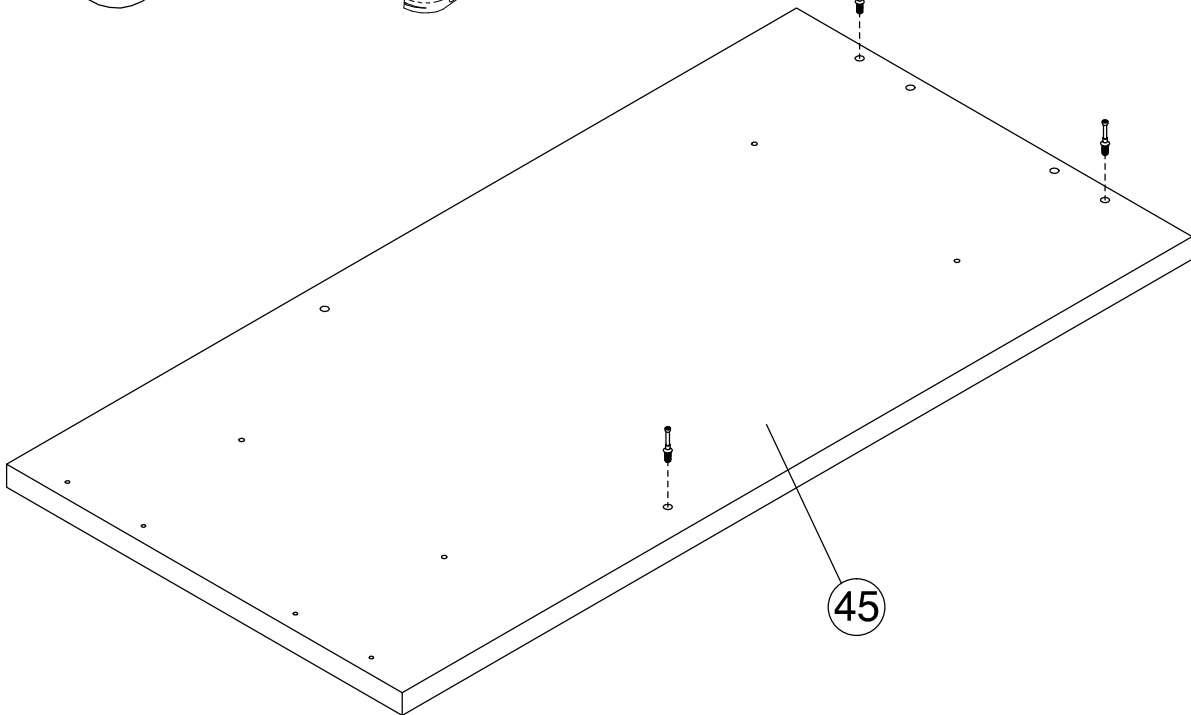
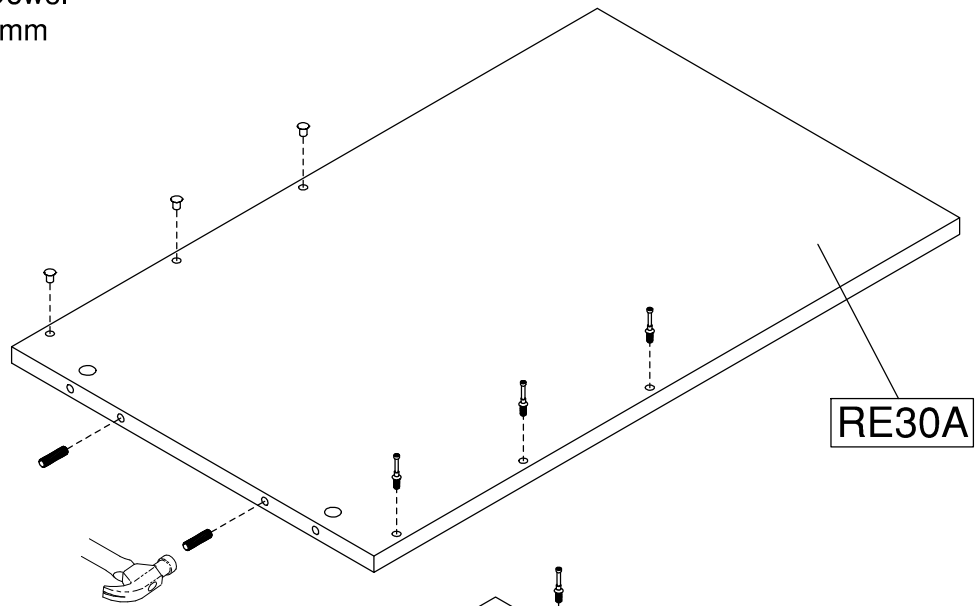
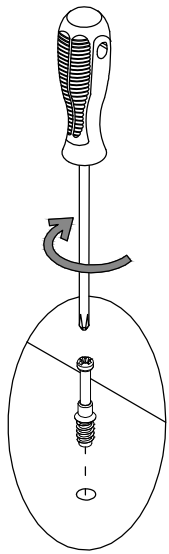

STEP 51

Assemble Panels

H181468 [3]
KD Cam
KD Cam

H170595 [3]
Cover Cap
Cover Cap

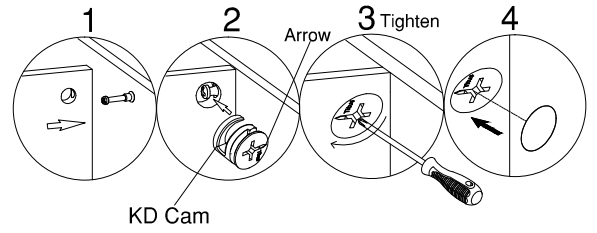

H170594 [1]
Cover Cap 15mm
Cover Cap 15mm

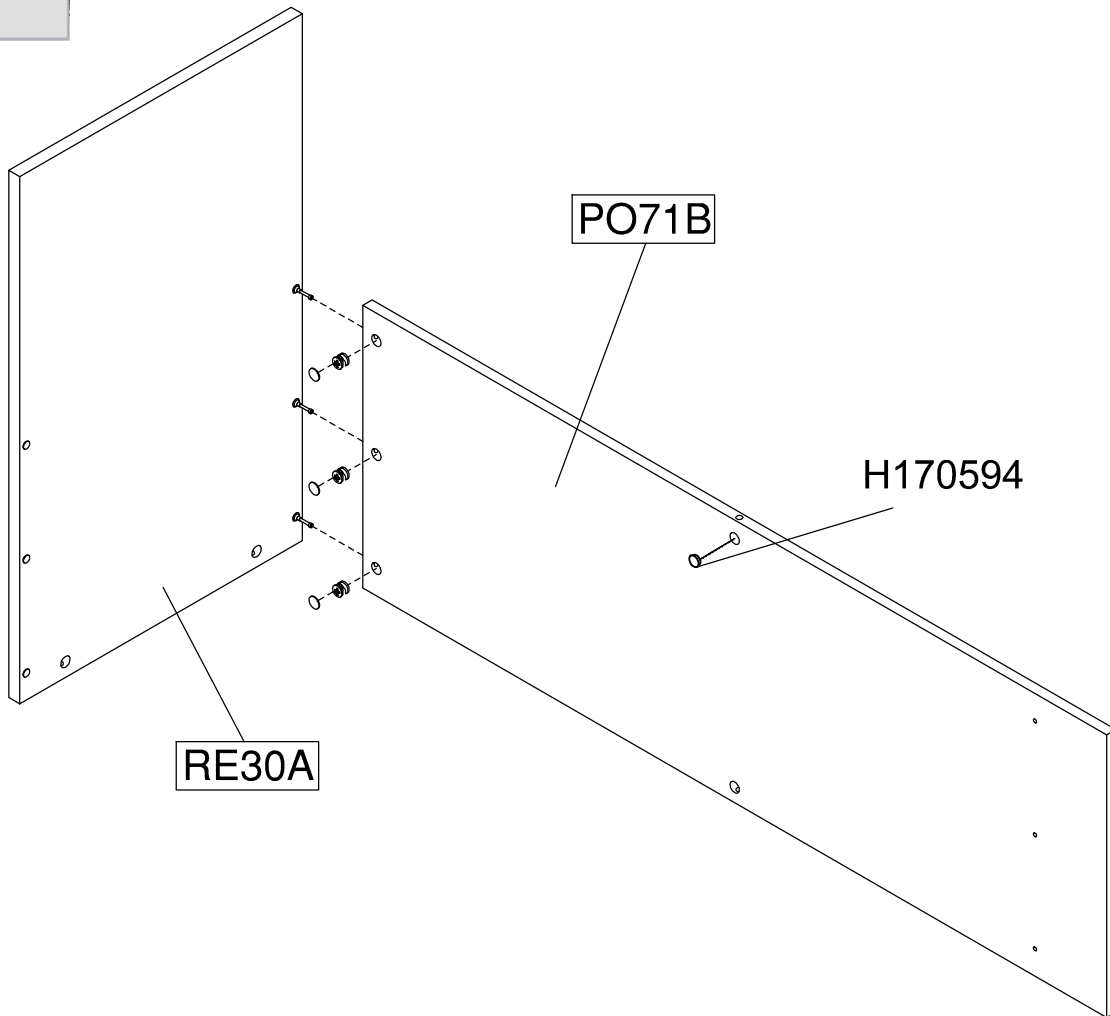
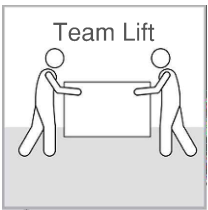

STEP 52

Assemble Panels

H181468 [3]
KD Cam

H170595 [3]
Cover Cap

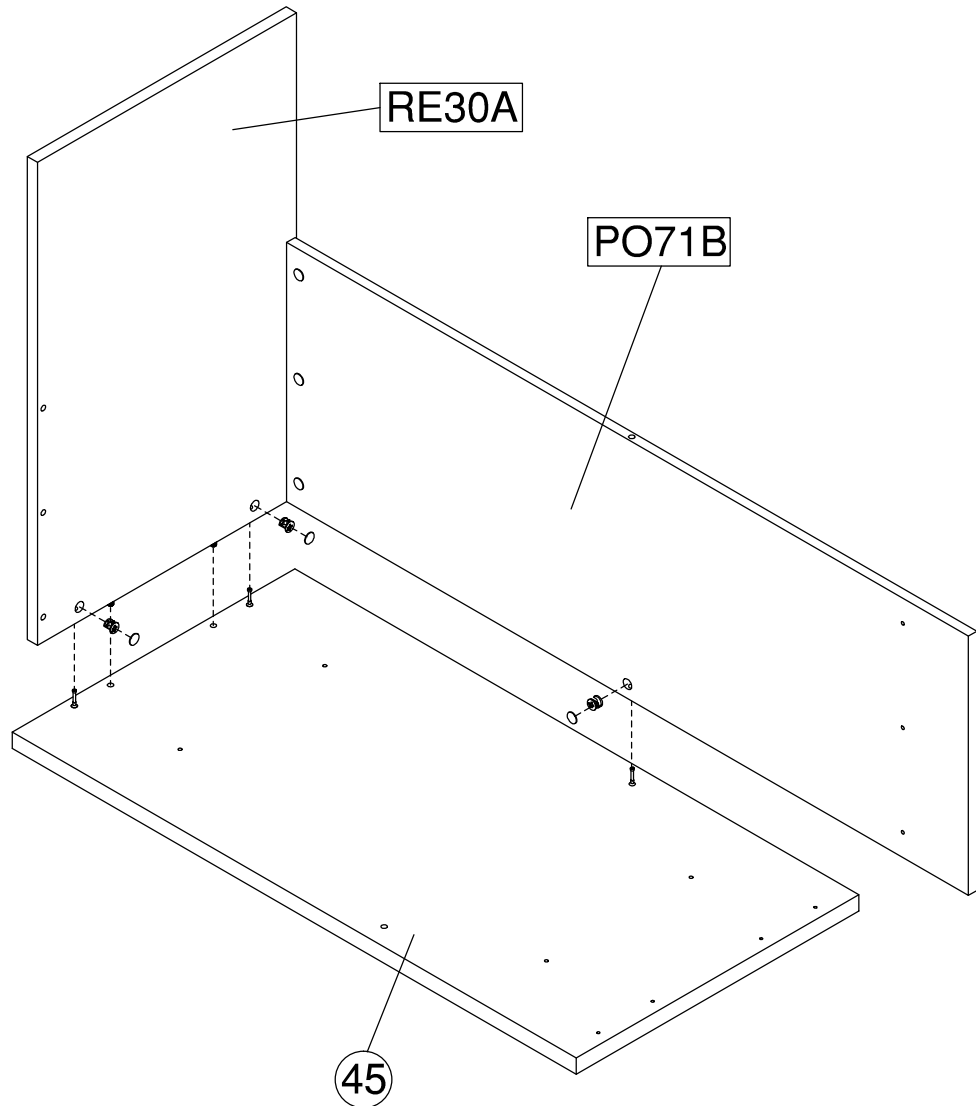
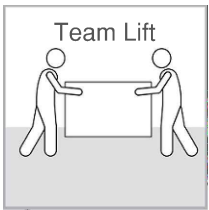
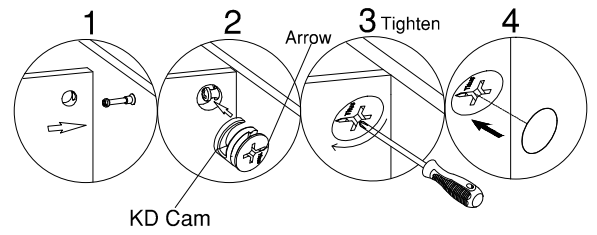

STEP 53

Assemble Panels

H175158

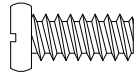

[4]

#12 x 9/16"

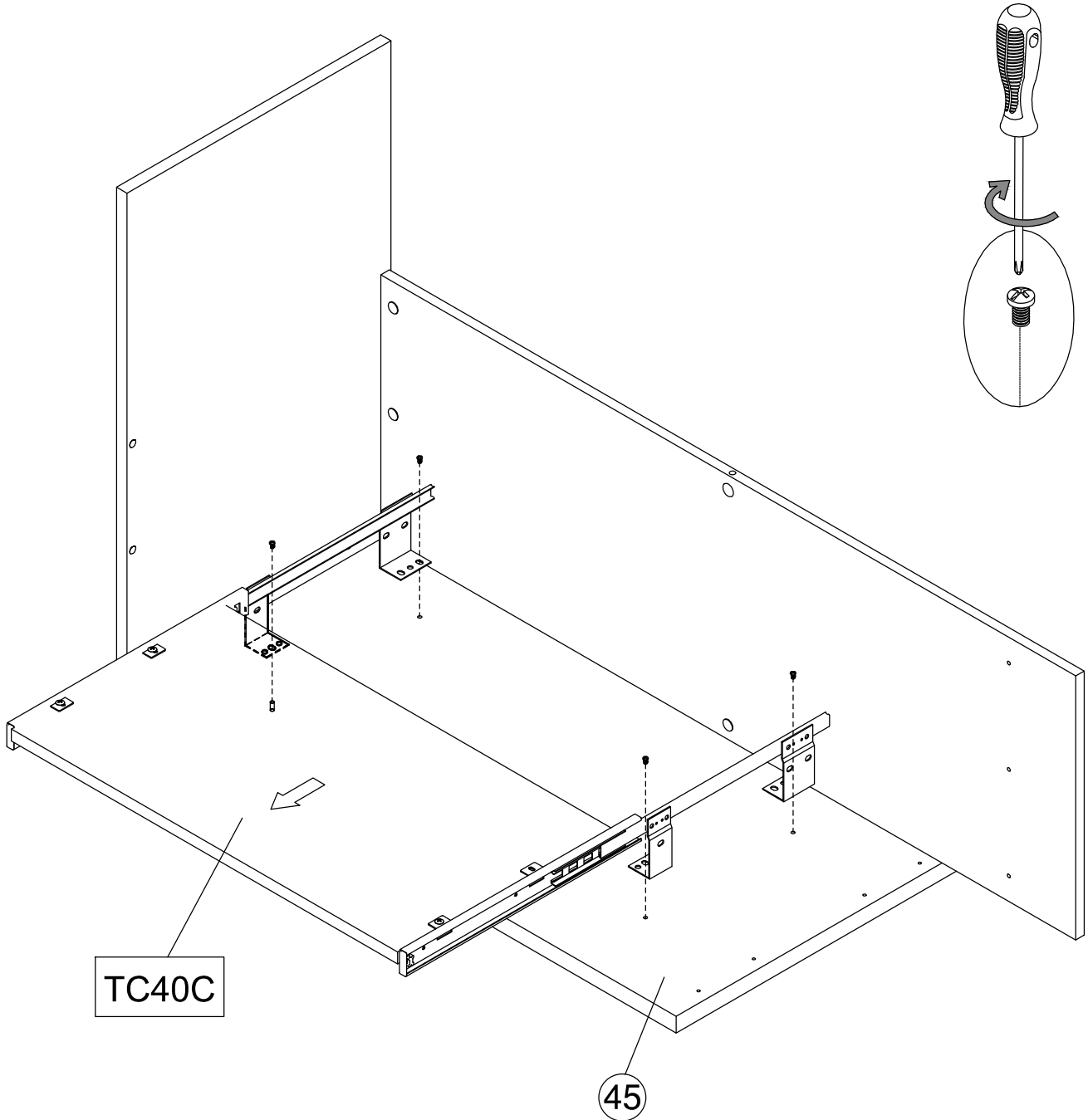

STEP 54

Assemble Panels

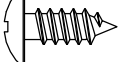

H35251  [4]
#10 x 1/2"

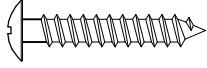
H150019  [3]
#8 x 1"

Tighten all screws.
Apriete todos los tornillos.
Serrez toutes les vis.

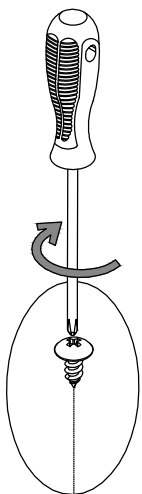
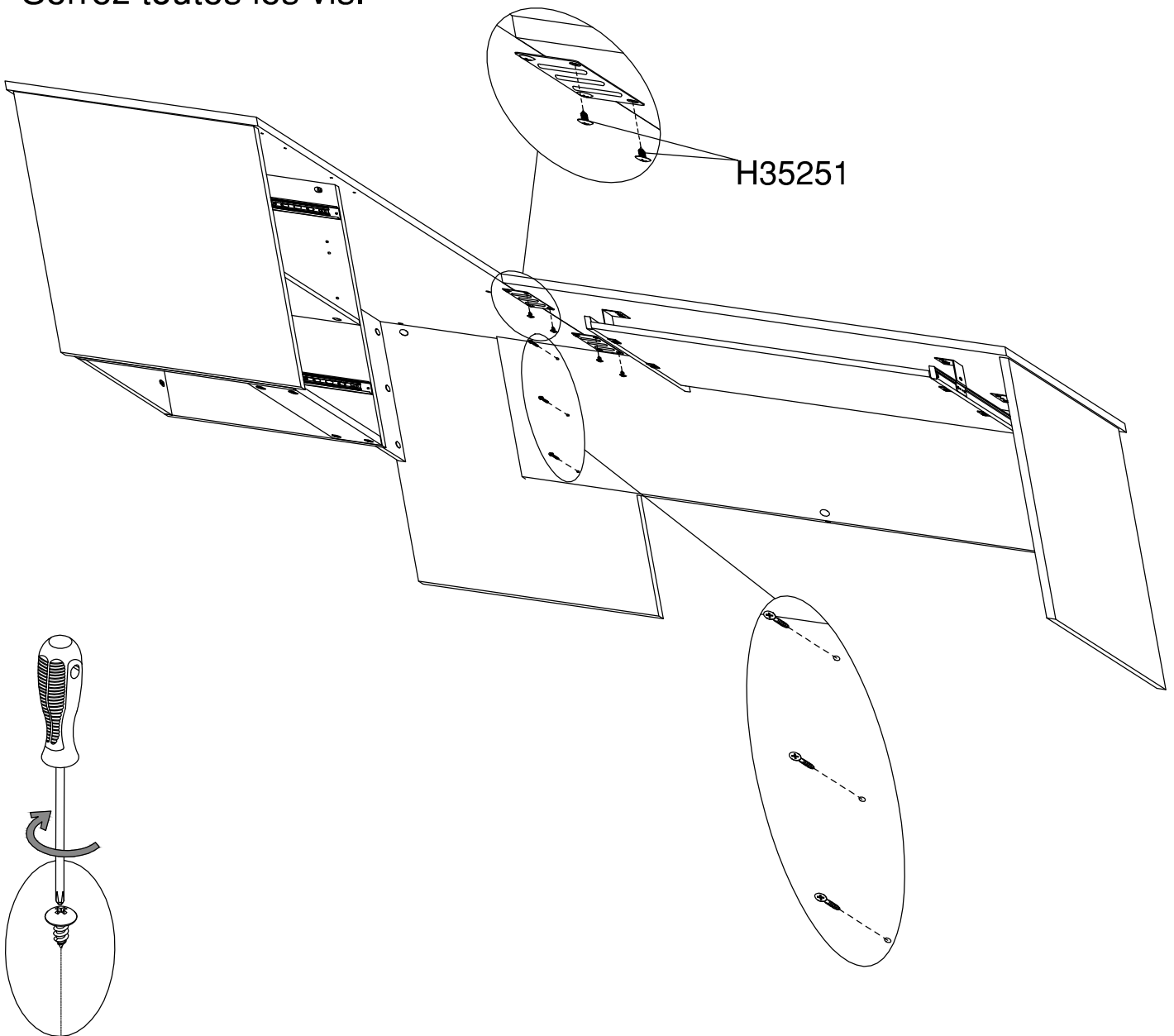

STEP 55

Assemble Panels

H181468

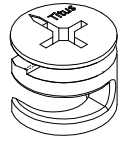

[2]

KD Cam

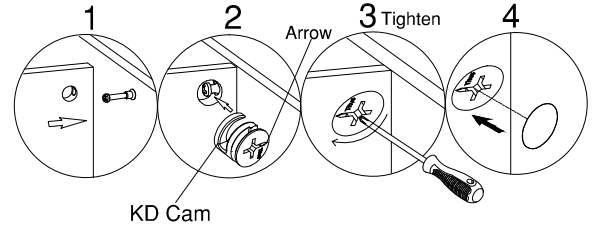

H170595

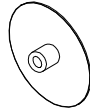

[2]

Cover Cap

H180604

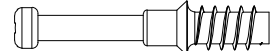

[2]

KD Bolt

H195624

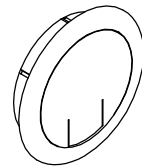

[1]

Grommet

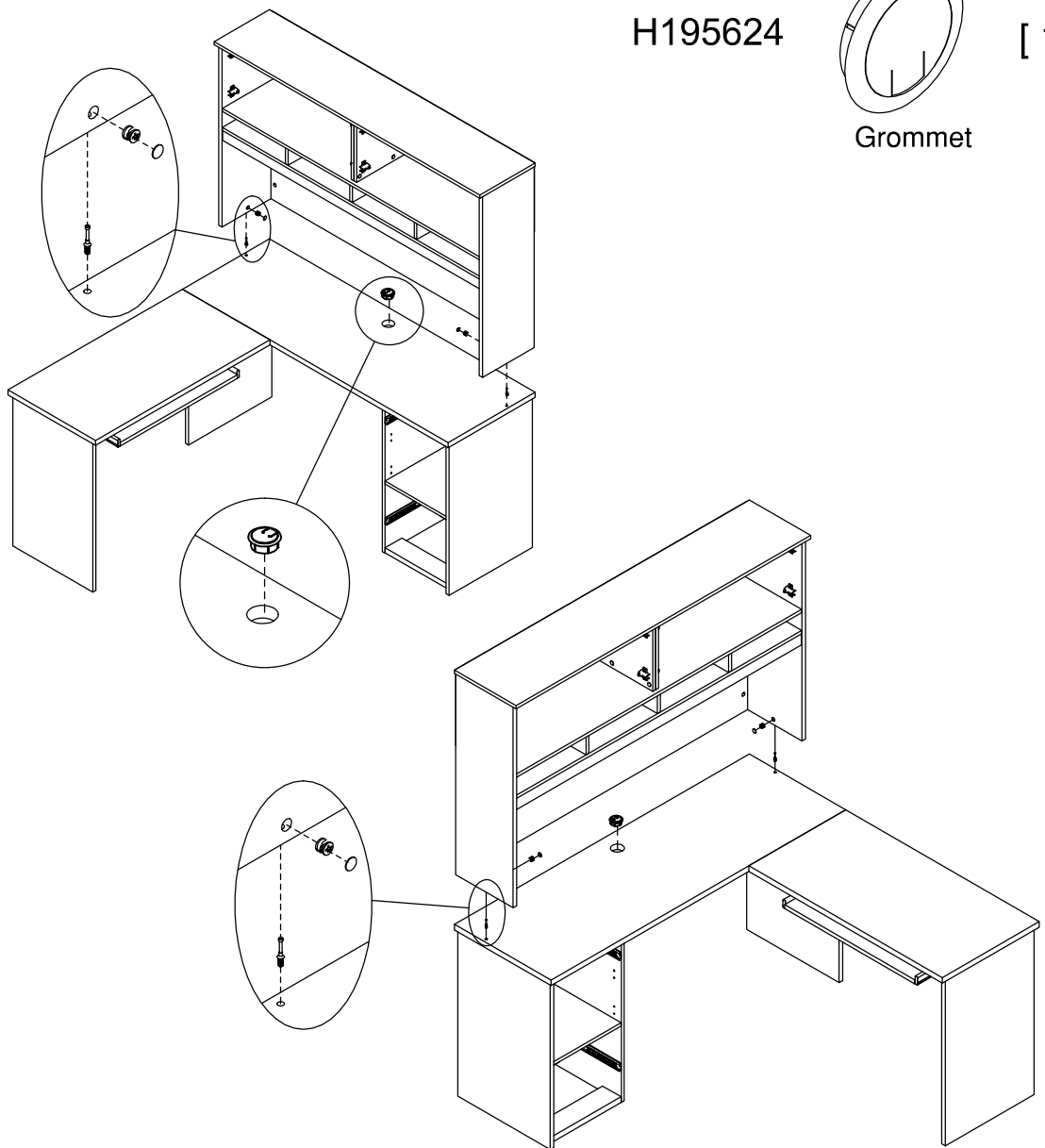

STEP 56

Prepare Panels

H85966

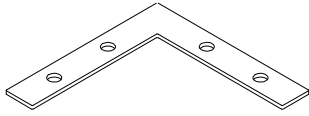

[2]

L" Bracket

H150019

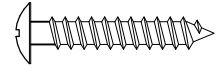

[8]

#8 x 1"

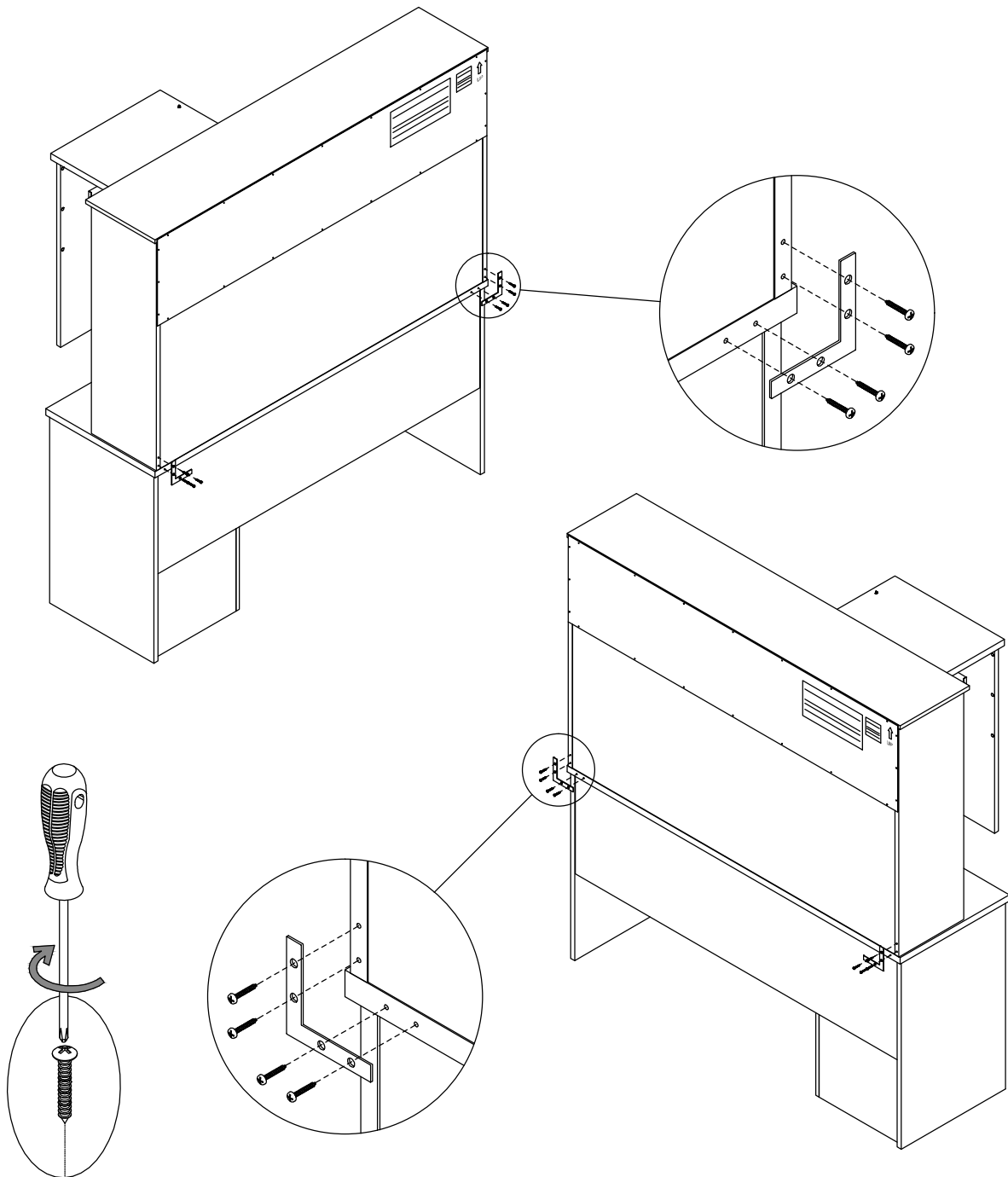

STEP 57

Prepare Panels

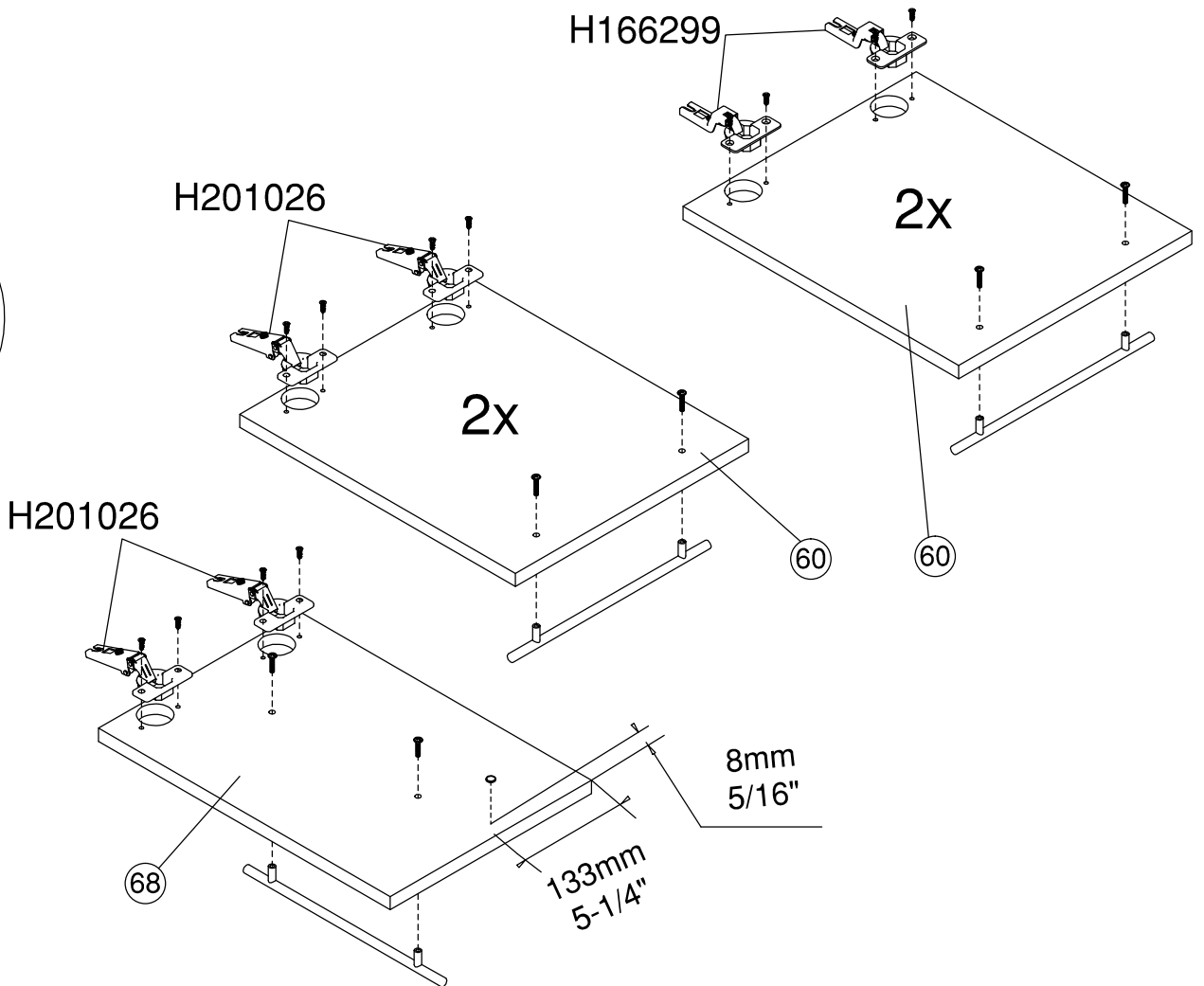
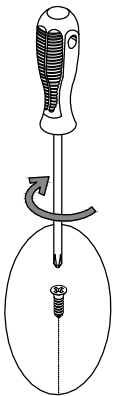
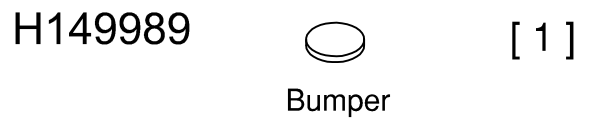
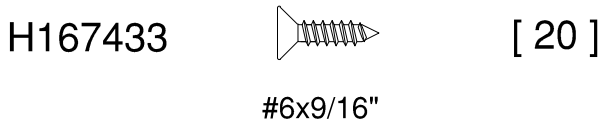
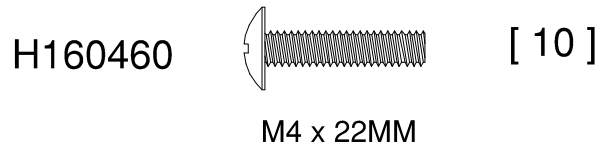
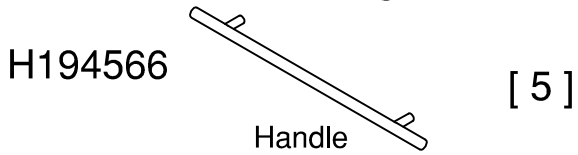
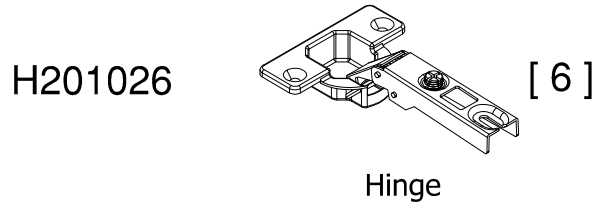
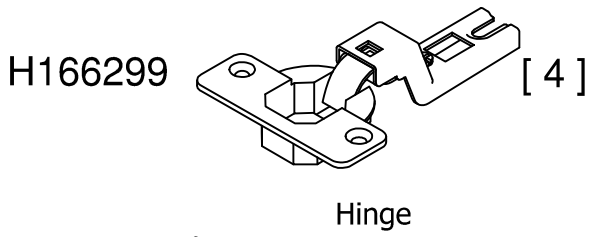

STEP 58

Assemble and Adjust Door

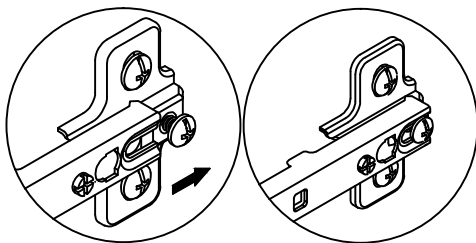
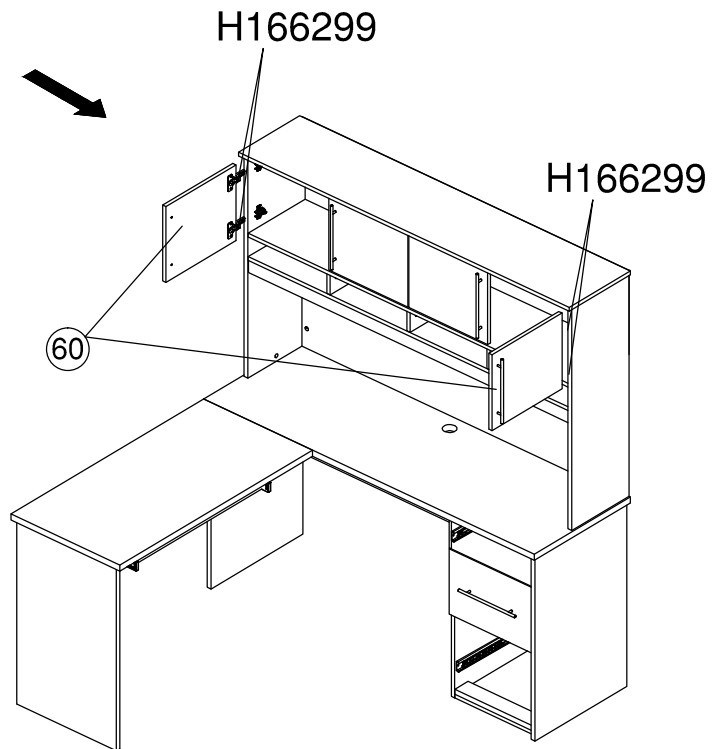
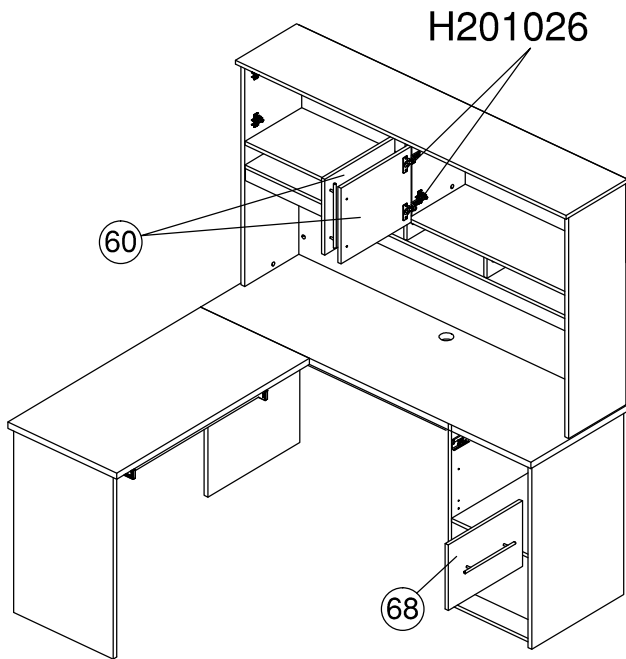
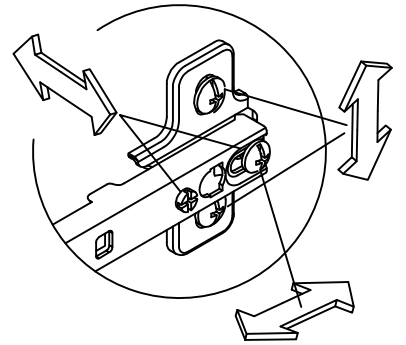
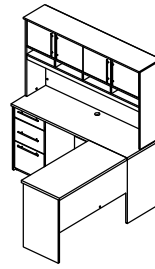
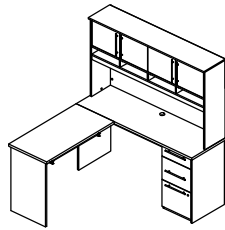

STEP 59

Install Drawers

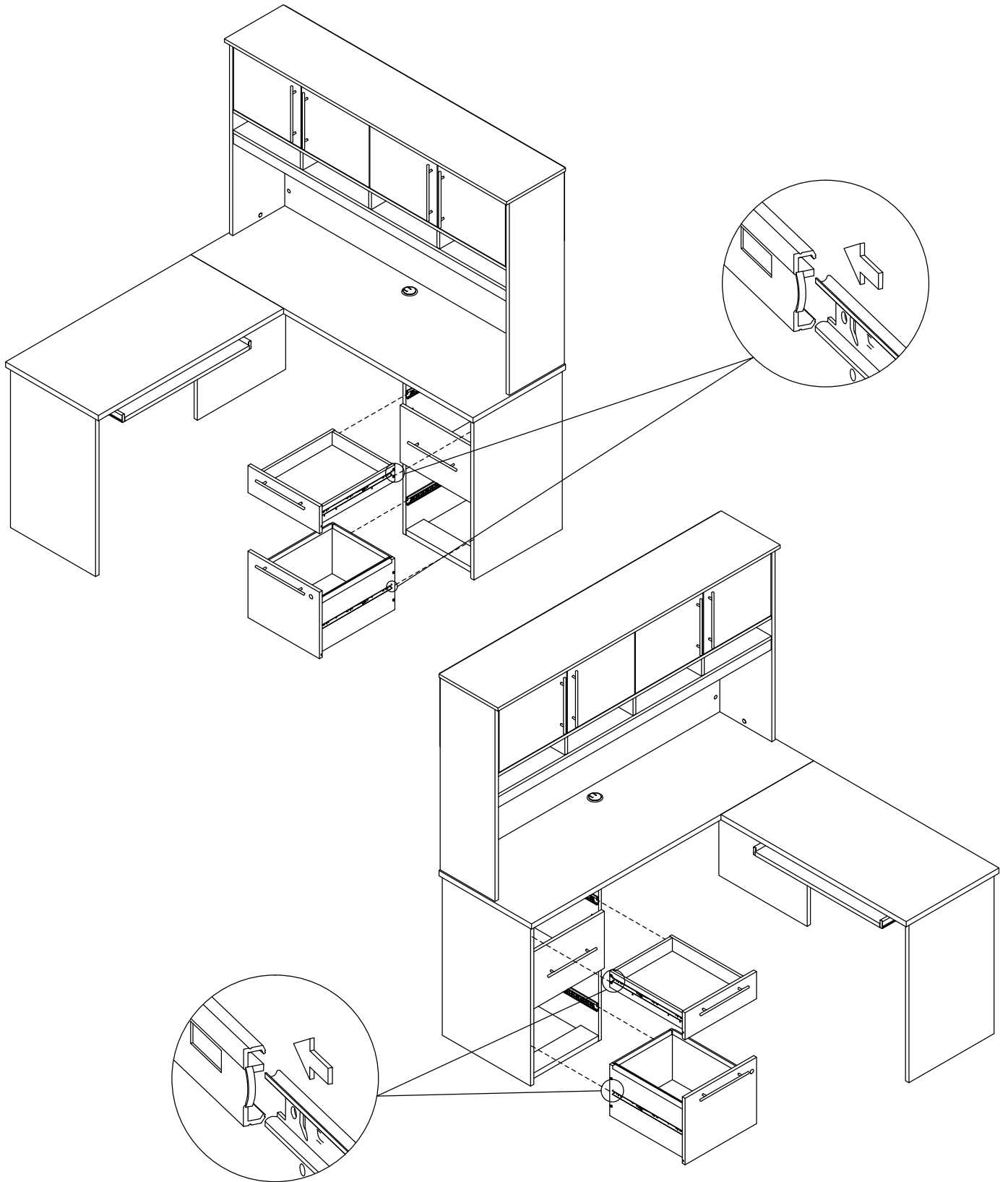

STEP 60

Drawer Adjustment

DRAWER FRONT VIEW

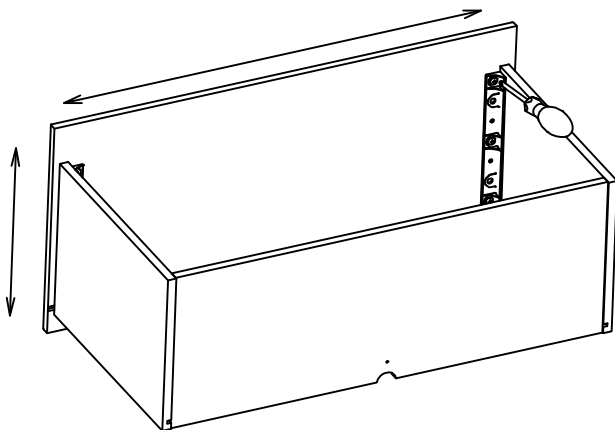
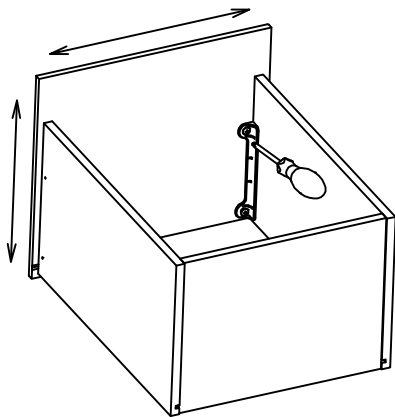
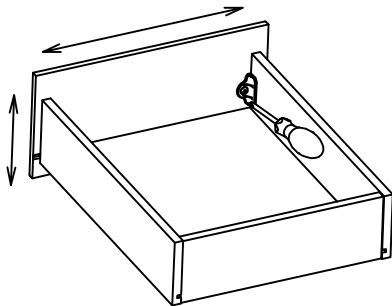
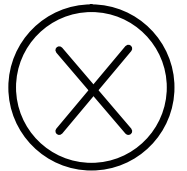
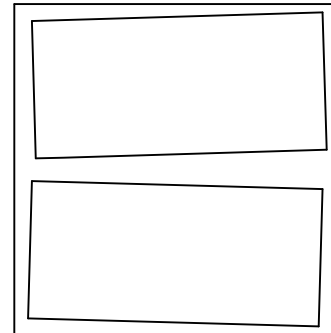
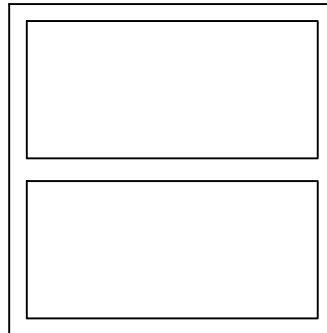

REQUIRED TOOL: PHILLIPS SCREWDRIVER

HERRAMIENTA REQUERIDA: DESTORNILLADOR PHILLIPS
OUTIL REQUIS: TOURNEVIS CRUCIFORME



1. LOOSEN SCREWS.
2. ADJUST DRAWER FRONTS.
3. TIGHTEN SCREWS.

1. Afloje los tornillos
2. Ajustar frentes de cajón
3. Apriete los tornillos

1. Desserrer les vis
2. Ajuster les façades des tiroirs
3. Serrer les vis

STEP 61

Maximum Loading and Cleaning

Gently clean surfaces with a damp sponge eraser.

MAXIMUM WEIGHT: 0 LBS (0 KG)
PESO MÁXIMO: 0 LIBRAS (0 KILOGRAMO)
POIDS MAXIMUM: 0 LIVRES (0 KILOGRAMME)

MAXIMUM WEIGHT: 30 LBS (13.61 KG)
PESO MÁXIMO: 30 LIBRAS (13.61 KILOGRAMO)
POIDS MAXIMUM: 30 LIVRES (13.61 KILOGRAMME)

MAXIMUM WEIGHT: 5 LBS (2.27 KG)
PESO MÁXIMO: 5 LIBRAS (2.27 KILOGRAMO)
POIDS MAXIMUM: 5 LIVRES (2.27 KILOGRAMME)

MAXIMUM WEIGHT: 200 LBS (90.72 KG)
PESO MÁXIMO: 200 LIBRAS (90.72 KILOGRAMO)
POIDS MAXIMUM: 200 LIVRES (90.72 KILOGRAMME)

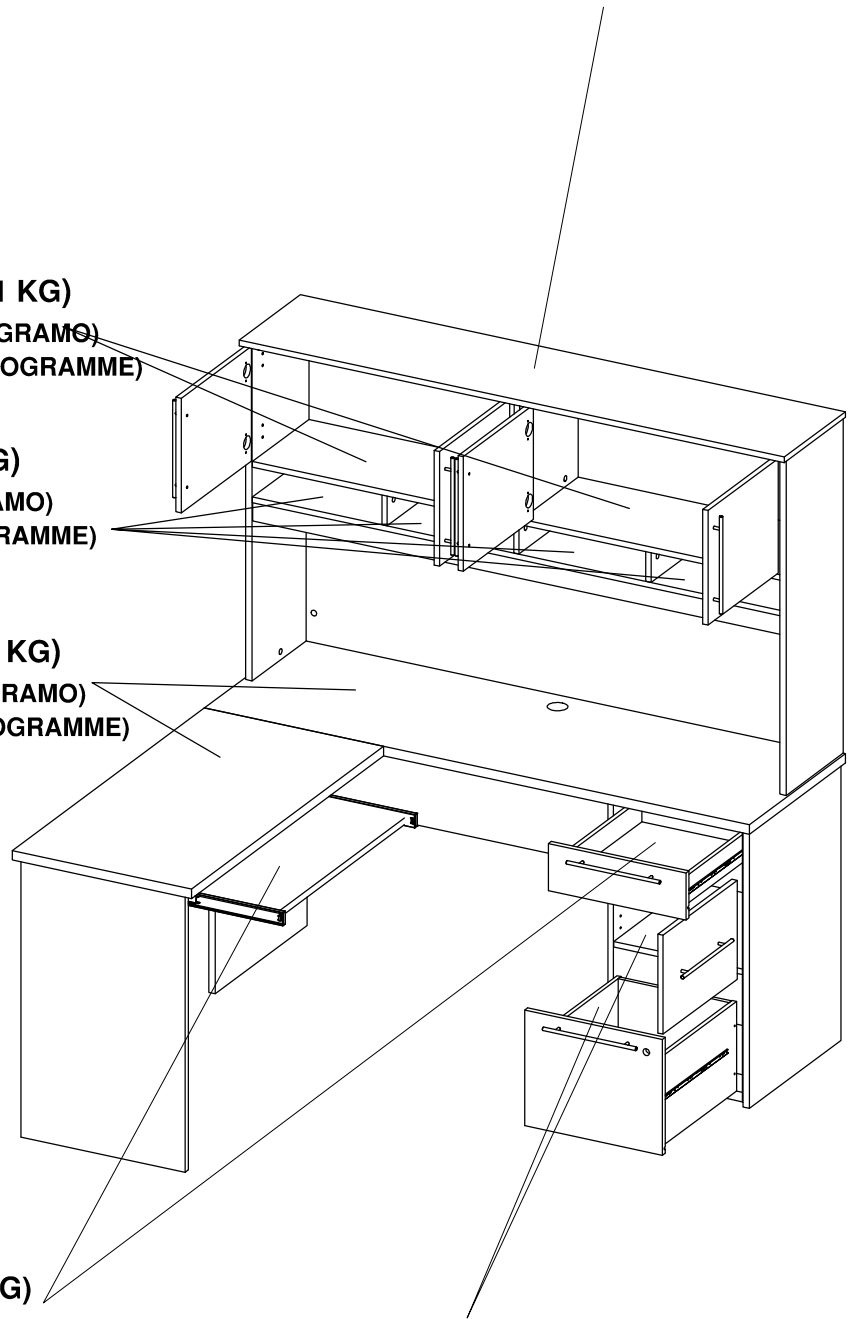

MAXIMUM WEIGHT: 15 LBS (6.8 KG)
PESO MÁXIMO: 15 LIBRAS (6.8 KILOGRAMO)
POIDS MAXIMUM: 15 LIVRES (6.8 KILOGRAMME)

MAXIMUM WEIGHT: 30 LBS (13.61 KG)
PESO MÁXIMO: 30 LIBRAS (13.61 KILOGRAMO)
POIDS MAXIMUM: 30 LIVRES (13.61 KILOGRAMME)