

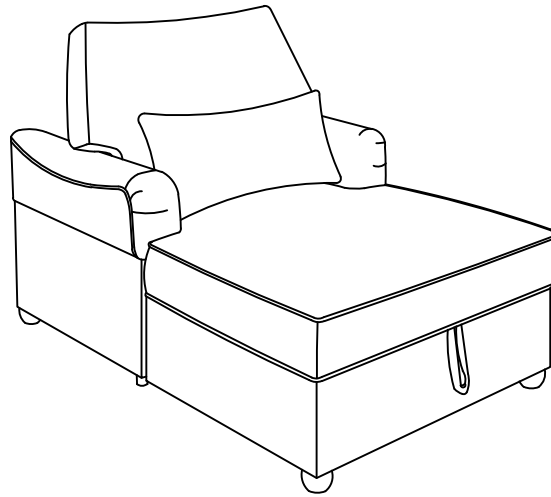

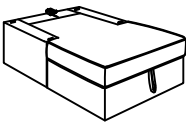

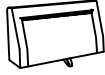

# ASSEMBLY INSTRUCTION

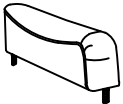
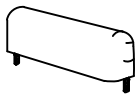





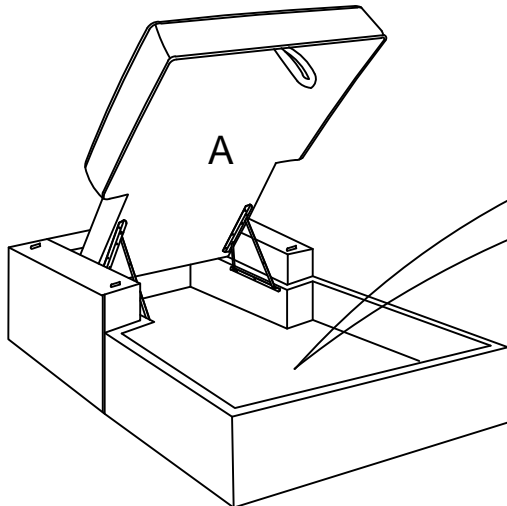

## PARTS LIST

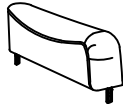
								 The bolt is screwed on the metal bracket	
A*1PC	B*1PC	C*1PC	D*1PC	E*1PC	F*1PC	G*4PCS	H*2PCS	I*1PC	J*1PC

**STEP 1** As shown in the figure: Open the seat frame (A) and remove the component.



			
B*1PC	C*1PC	D*1PC	E*1PC
			
F*1PC	G*4PCS	H*2PCS	J*1PC

**STEP 2** Please note that the fixed strip-like parts are facing outward. As shown in the figure, insert the armrests (C) and (D) into the seat frame (A) respectively.

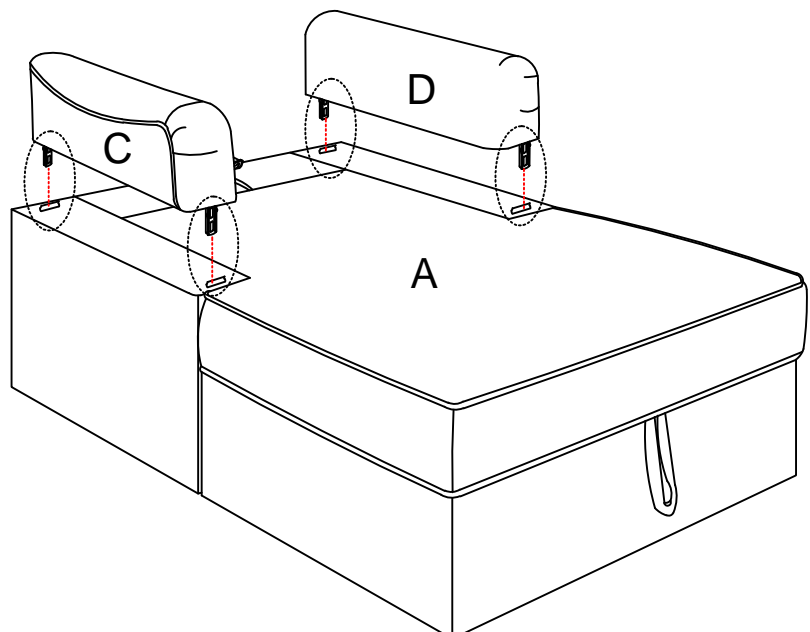
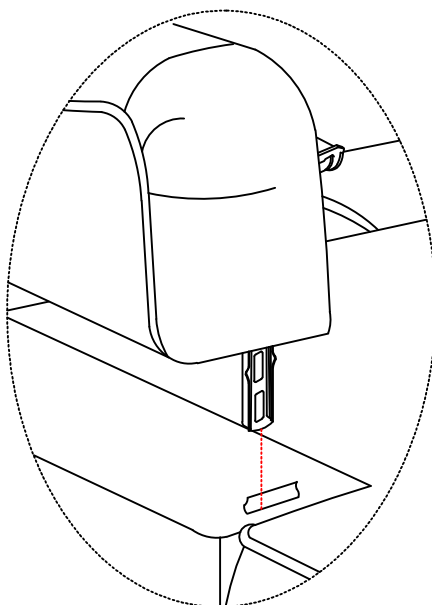

**STEP 3** The metal part to connect the backrest to the seat is already attached to the seat (A).  
Remove the bolts (I) from the metal kit before assembling the backrest (B).

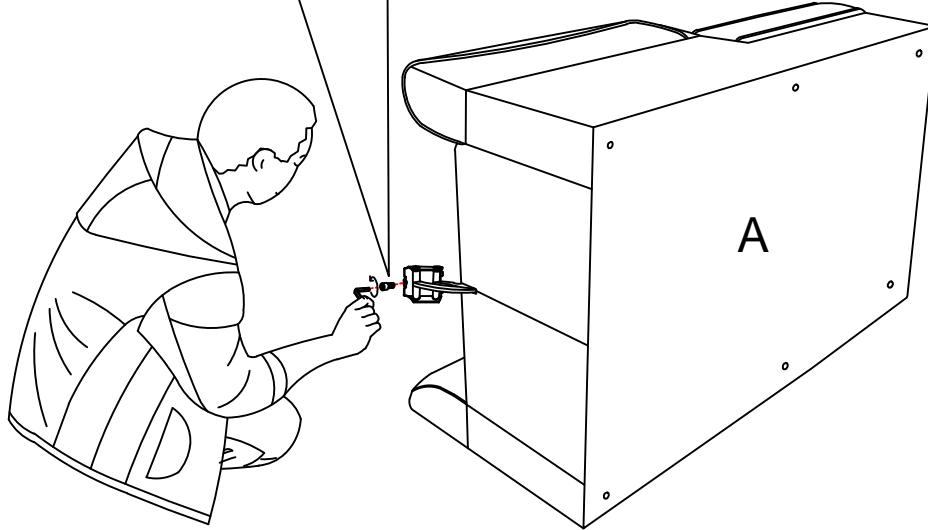
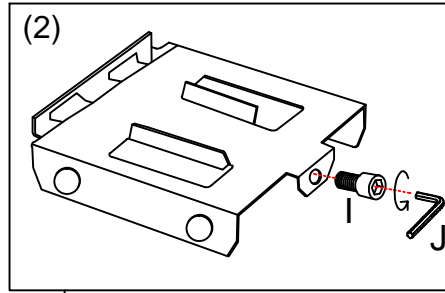
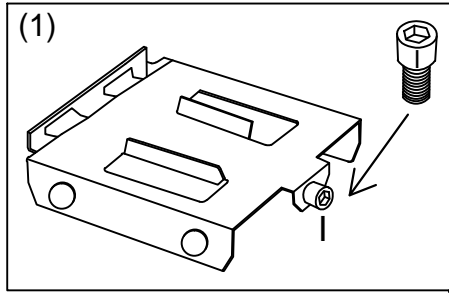

**STEP 4** Install the backrest (B) to the metal kit from Seat (A), using the bolts (I) and the allen key (J) as shown in the diagram.

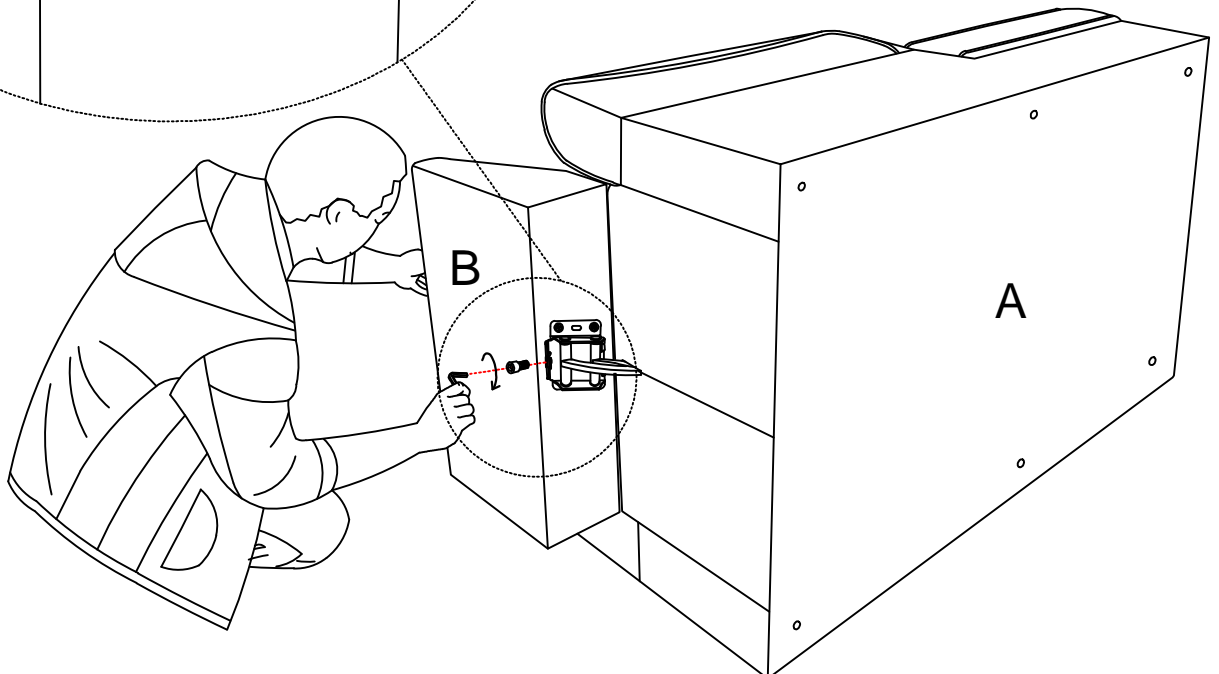
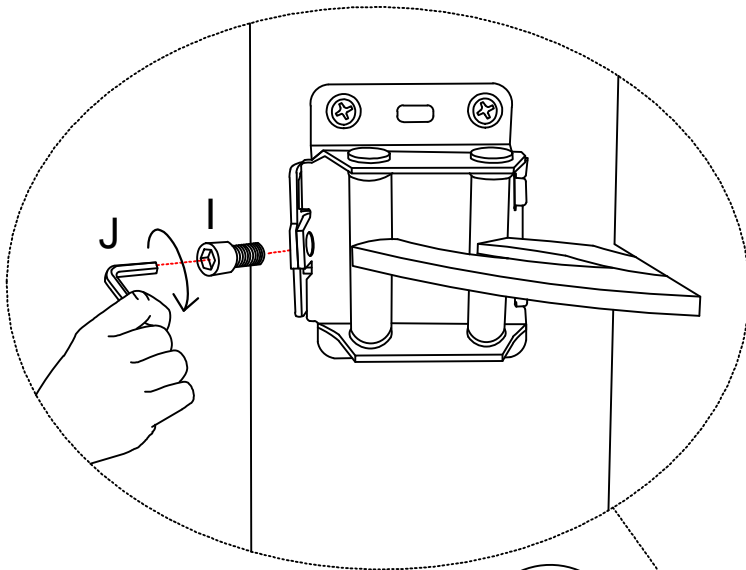

**STEP 5** As shown in the figure: Install wooden feet (G) and plastic feet (H) at the corresponding positions on the bottom of the seat (A).

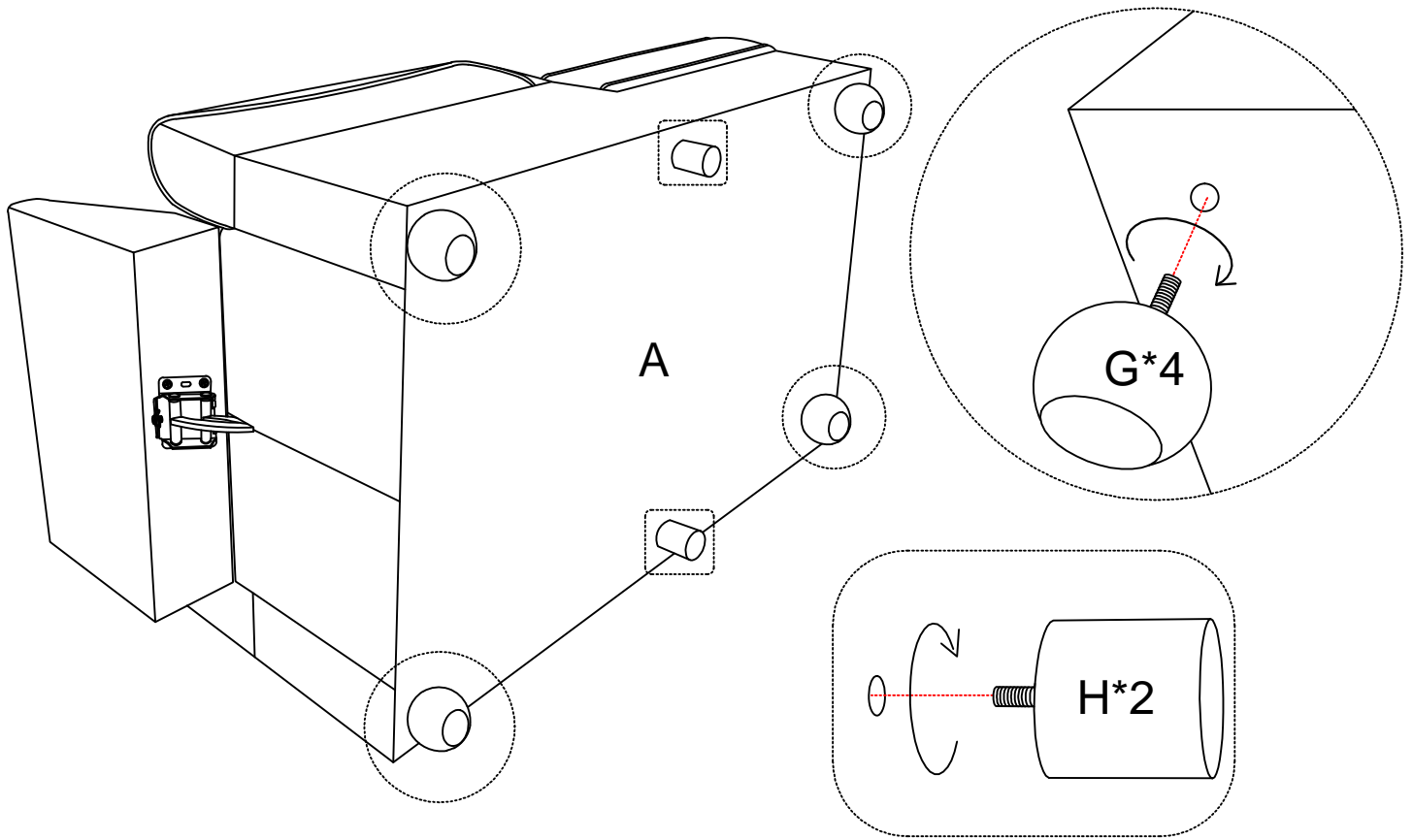

**STEP 6** Move the backrest (B) forward and backward using this rope.

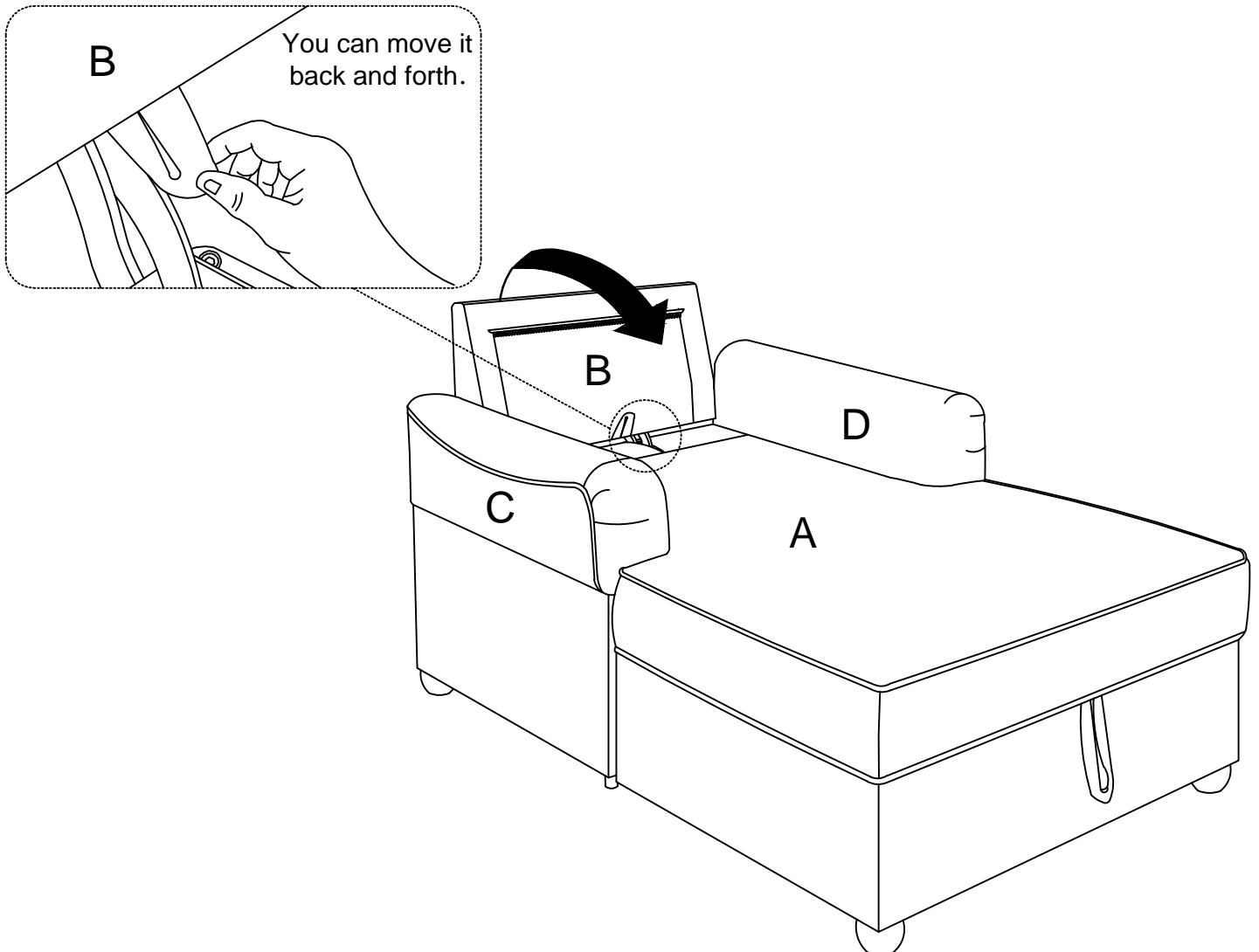

STEP 7 As shown in the figure: Pull the zipper of the backrest (B) and the backrest cushion (E) tight.

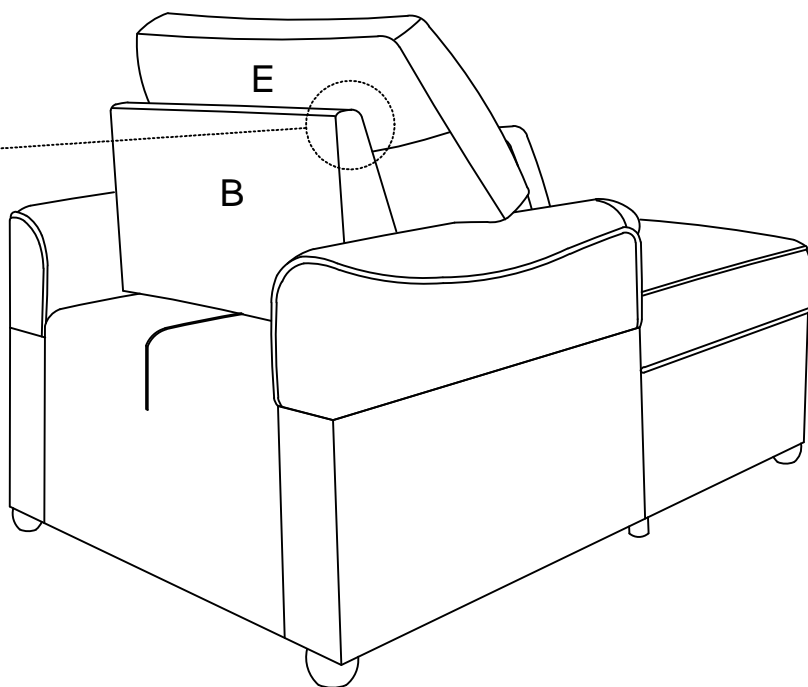
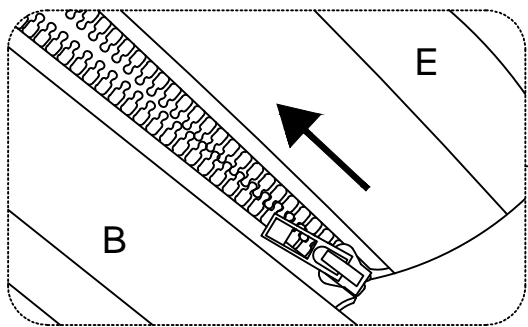

STEP 8 Assembly completed.

