

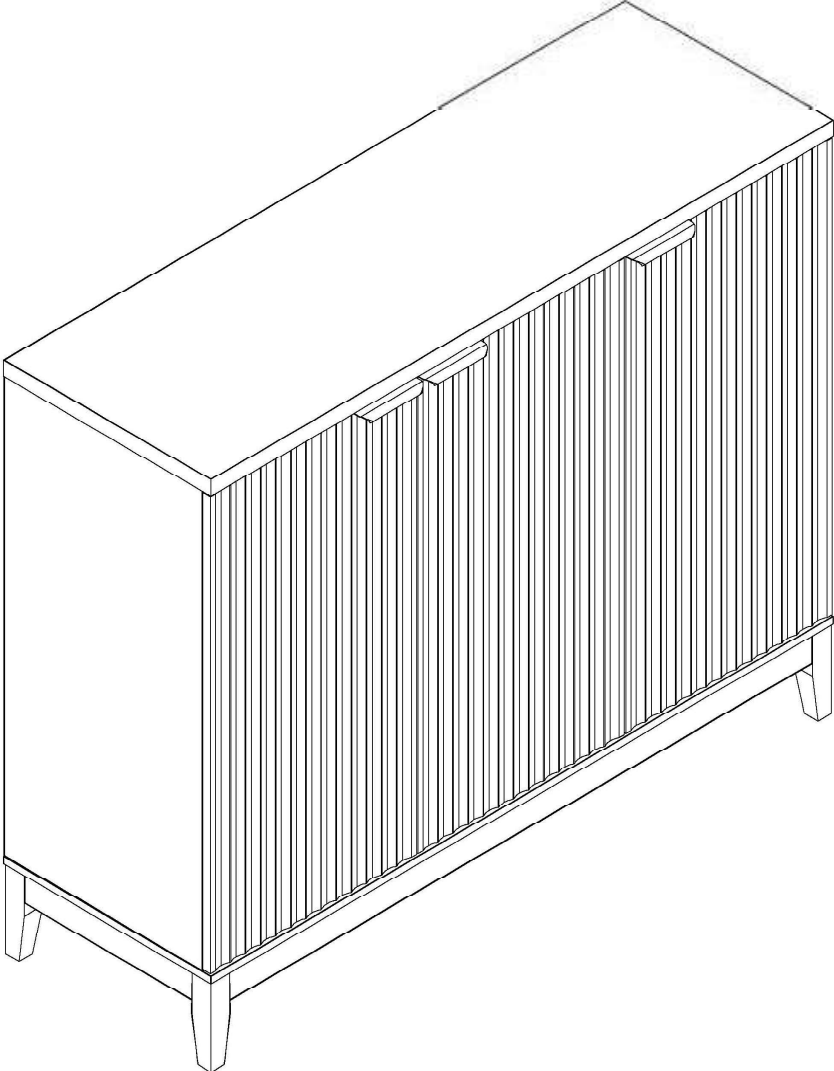

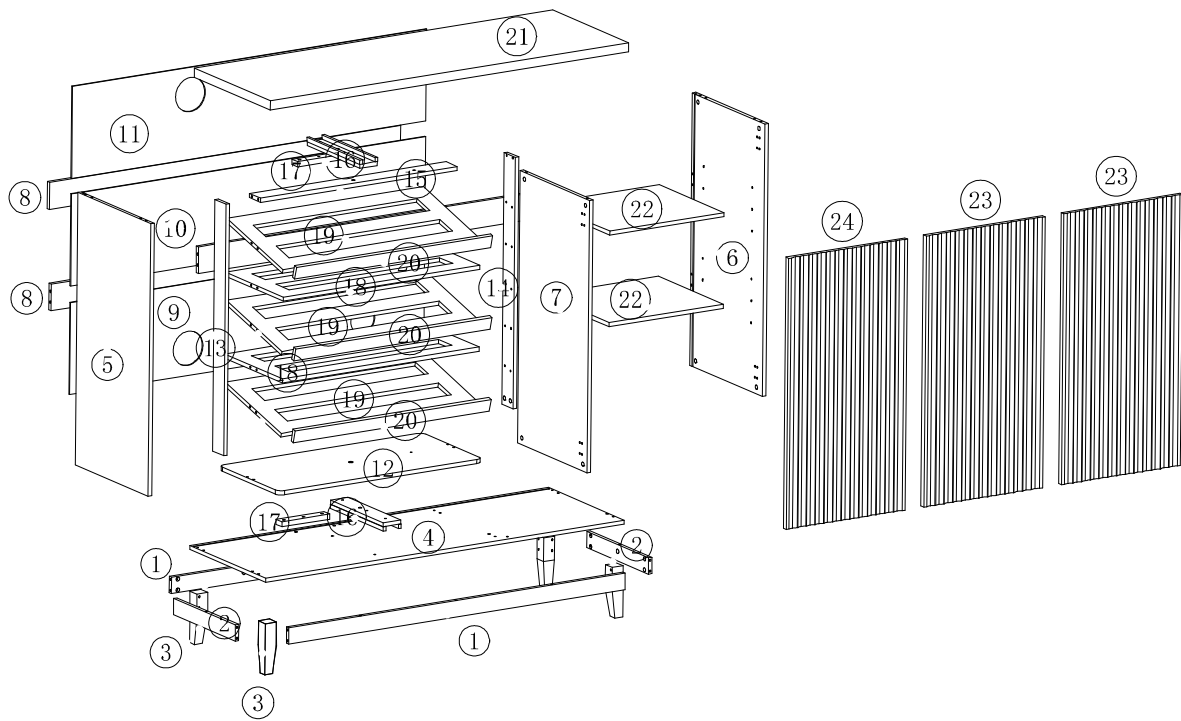

Product structure decomposition

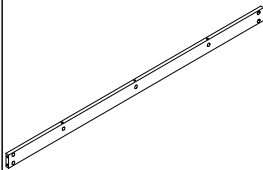
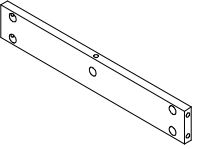
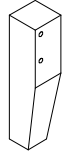
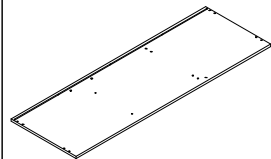

Product structure decomposition

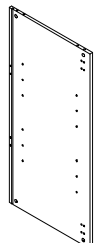
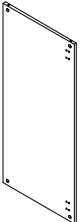
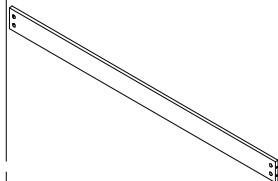
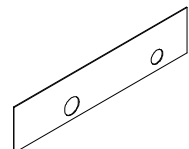
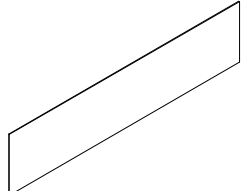
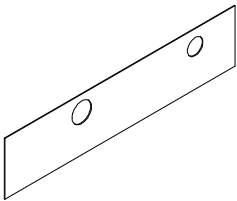
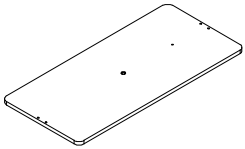

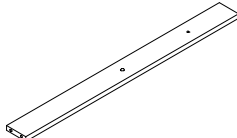
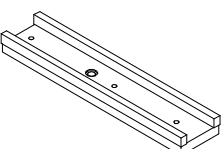
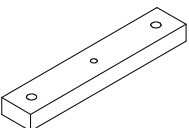
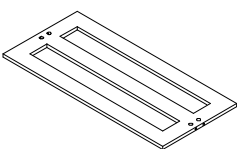
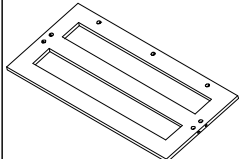
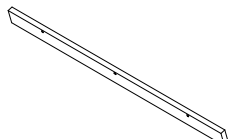
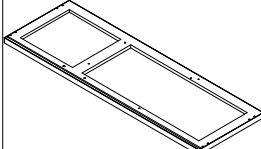
| | | | | | |
|---|---------------|---|---------------|---|---------------|
|  | 1 x 2 |  | 2 x 2 |  | 3 x 4 |
|  | 4 x 1 |  | 5 x 1 |  | 6 x 1 |
|  | 7 x 1 |  | 8 x 2 |  | 9 x 1 |
|  | 10 x 1 |  | 11 x 1 |  | 12 x 1 |
|  | 13 x 1 |  | 14 x 1 |  | 15 x 1 |
|  | 16 x 2 |  | 17 x 2 |  | 18 x 2 |
|  | 19 x 3 |  | 20 x 3 |  | 21 x 1 |

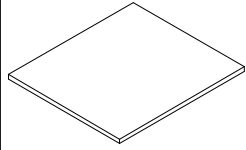

22X 2

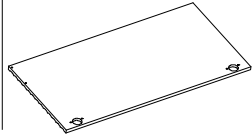



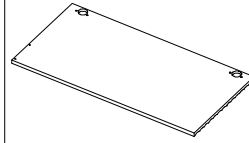



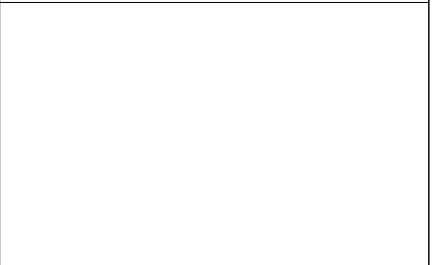
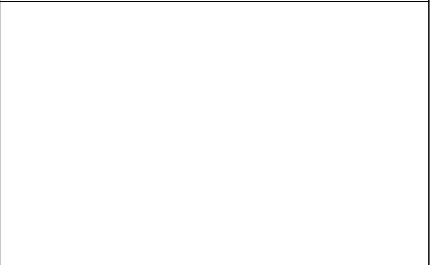
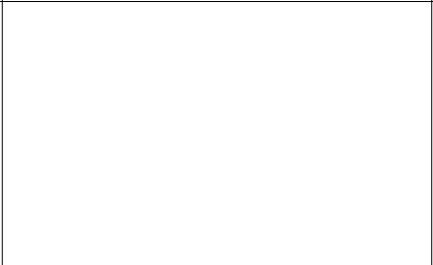
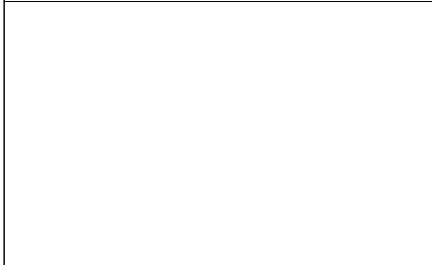
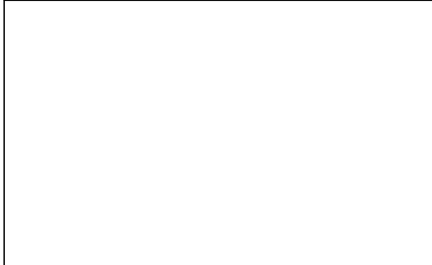
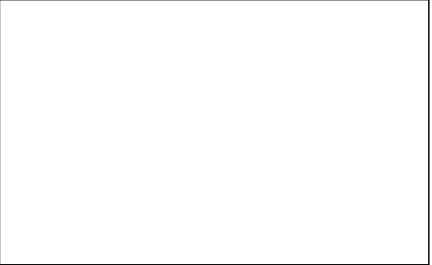
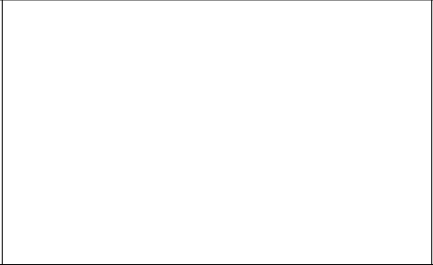
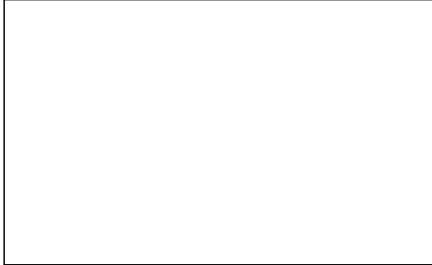



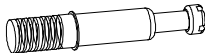

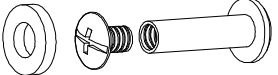
23X 2

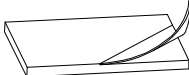
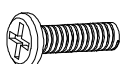
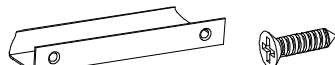

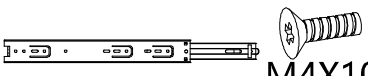
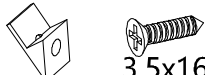
24X 1

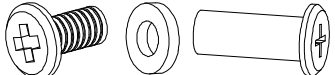

Accessories list

| | | | |
|---|---|--------------------------|--------------|
| A |  6X28mm | Two In One Screw | 81 pcs |
| B |  10x12mm | Two In One Nut | 81 pcs |
| C |  5x17mm | Male and female screws | 4 pcs |
| D |  6x30mm | Wood Chipping | 10 pcs |
| E |  | Foot rubber pad | 4 pcs |
| F |  | Screw (6x20mm) | 4 pcs |
| G |  | Handle & screw(3.5X12mm) | 3 pcs /6 pcs |
| H |  | Iron sheet | 2 pcs |
| I |  M4X10 | Screw & Guide (12 inch) | 2 pcs-10 pcs |
| J |  3.5x16mm | Fixing Clip & Screw | 12 pcs |
| K |  3.5X14 M4X10 | Hinge | 12-6-24pcs |
| L |  | Dowel Pin | 2 pcs |
| M |  | Shelf Bracket | 8 pcs |
| N |  4x45mm 3.5x10mm | Anti Fall Hardware | 2-2-2-2-4pcs |
| P |  M6X10- 10X2 8x22mm | parent-child screw | 2pcs |
| S |  | Iron gasket | 1pcs |

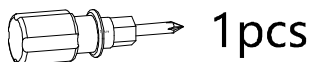

1 pcs

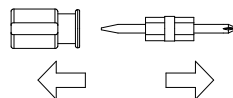

Double-head screwdriver, use as required

Use parts ① and ②

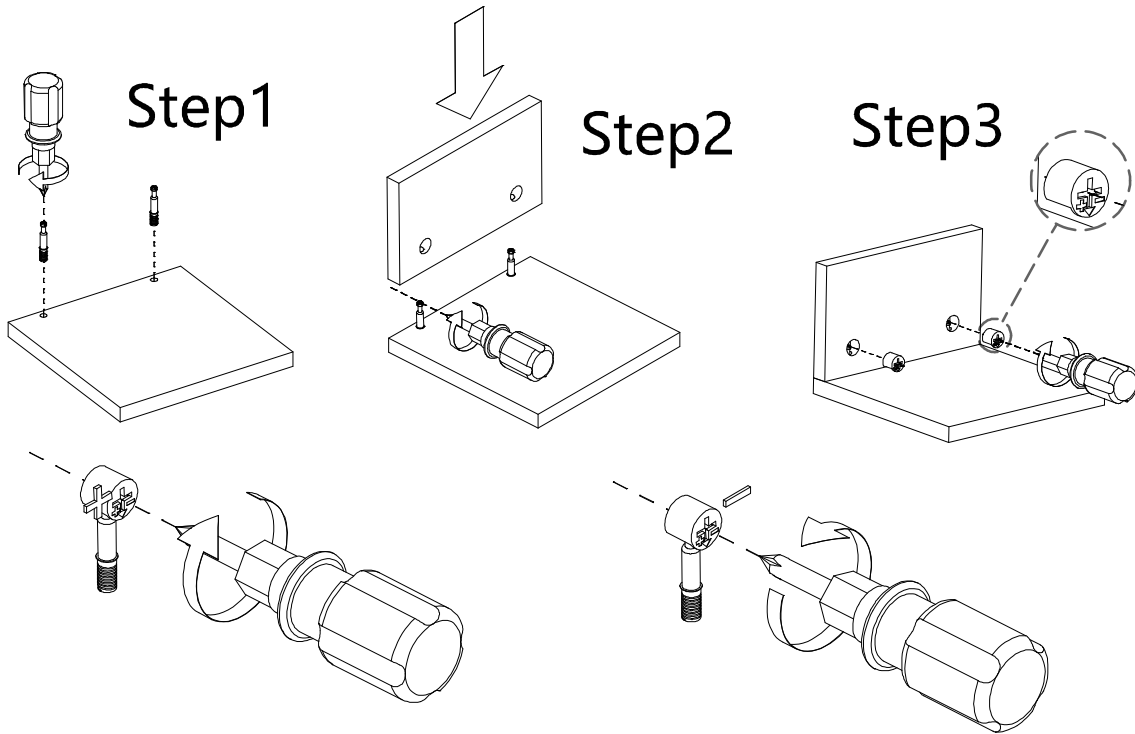

Use a screwdriver to lock in the direction of the "+" sign

Disassemble along the direction of "-" sign

Step 1

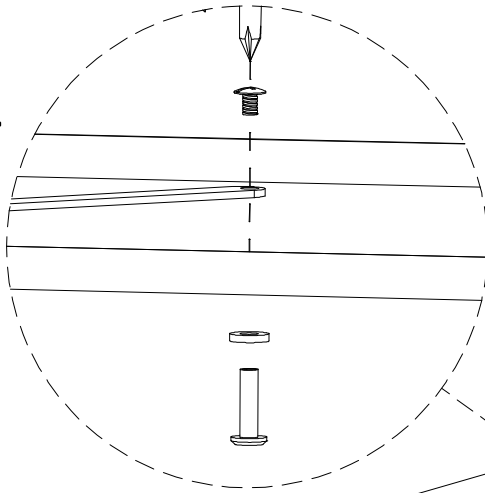

| Code | Diagram | count |
|------|---------|-------|
| C | | 1 |
| C | | 1 |
| H | | 1 |

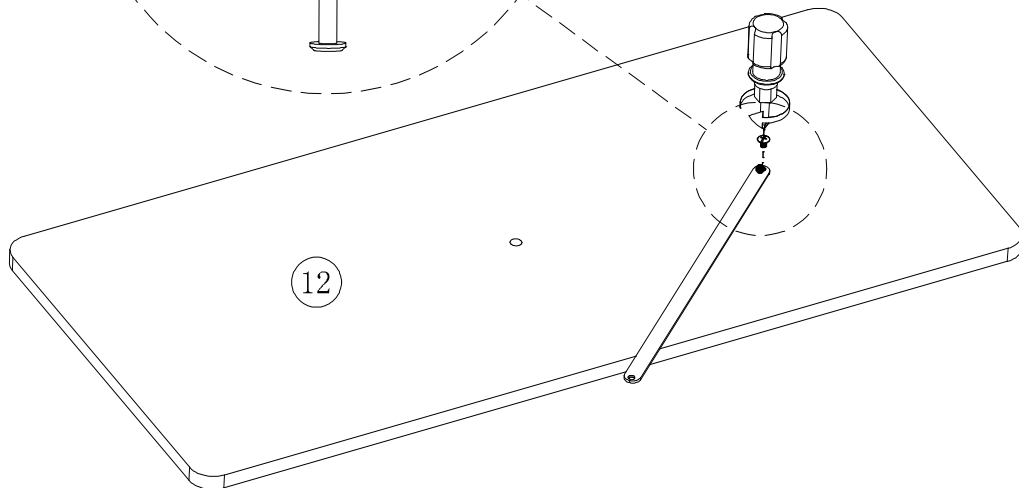

Step2

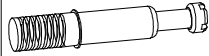
| Code | Diagram | count |
|----------|---|----------|
| A |  | 3 |

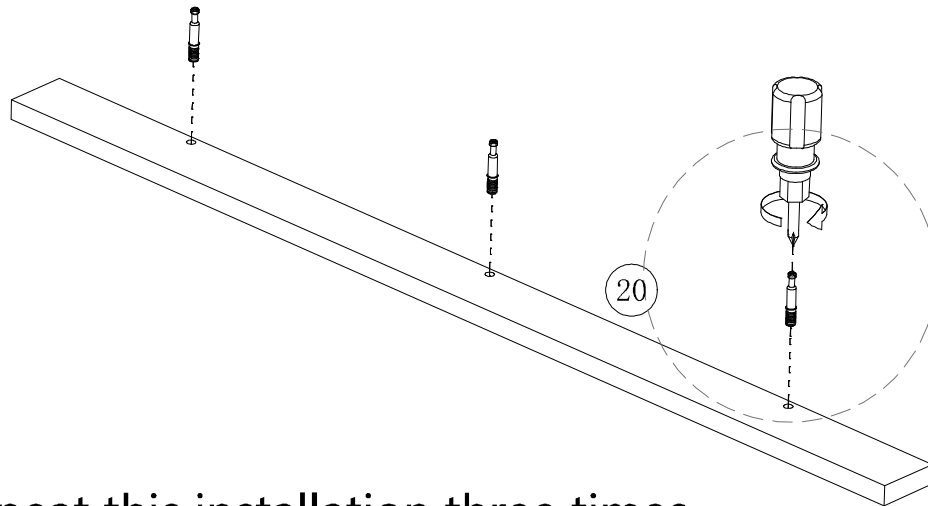

Repeat this installation three times

Step3

| Code | Diagram | count |
|----------|---|----------|
| B |  | 3 |

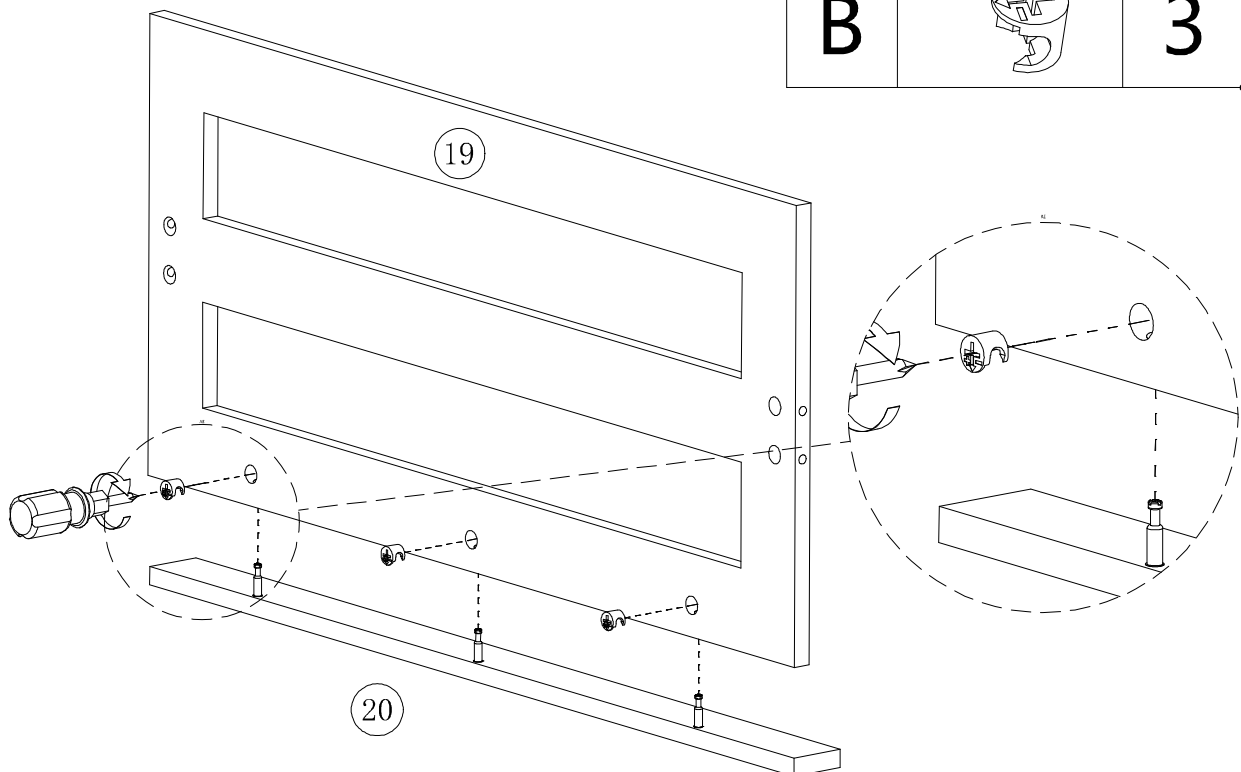

Repeat this installation three times

Step4

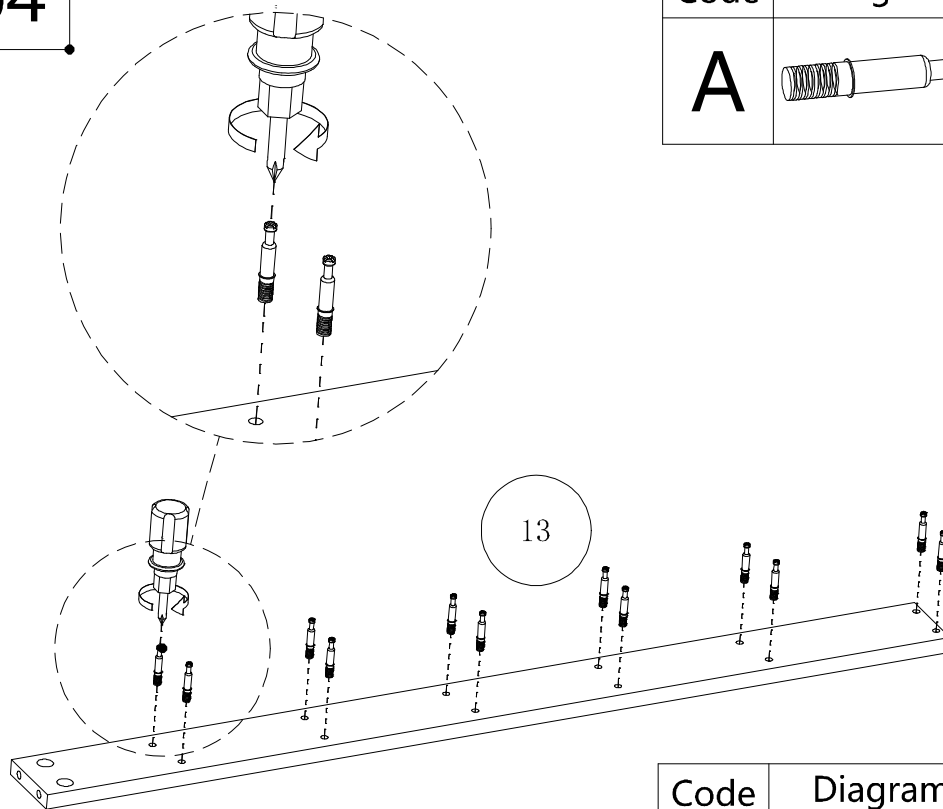

| Code | Diagram | count |
|------|---|-------|
| A |  | 12 |

Step5

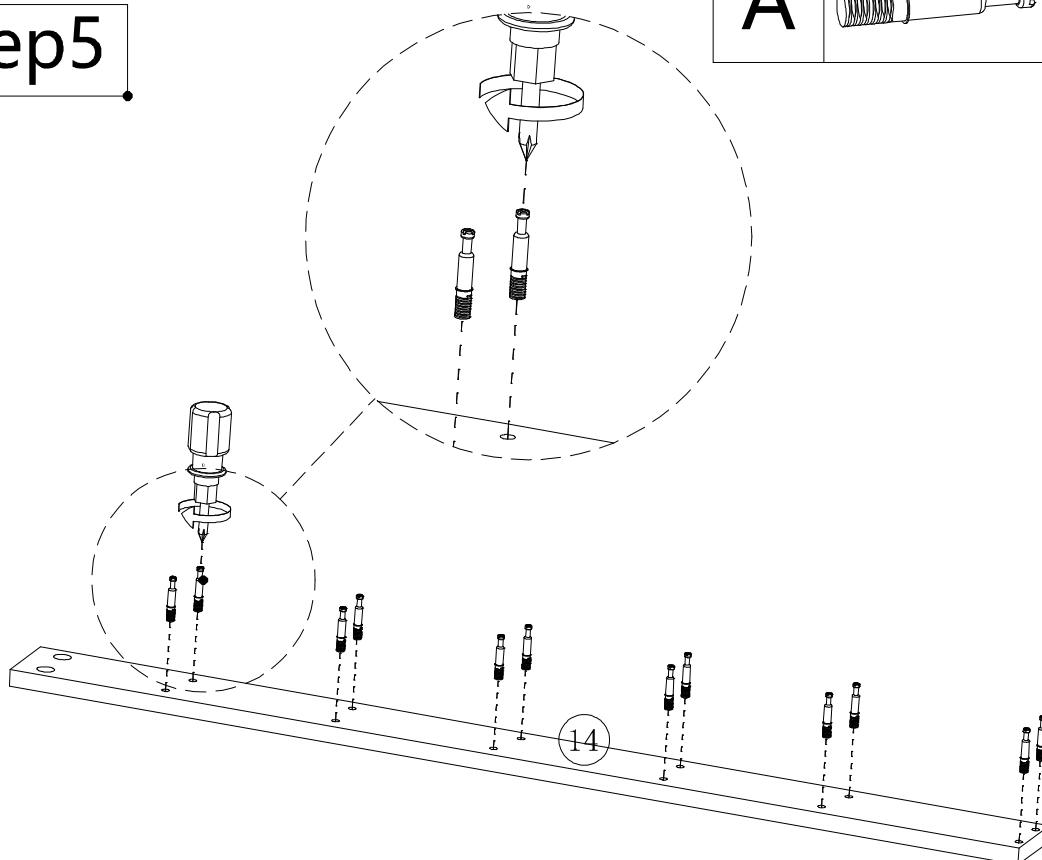

| Code | Diagram | count |
|------|---|-------|
| A |  | 12 |

Step6

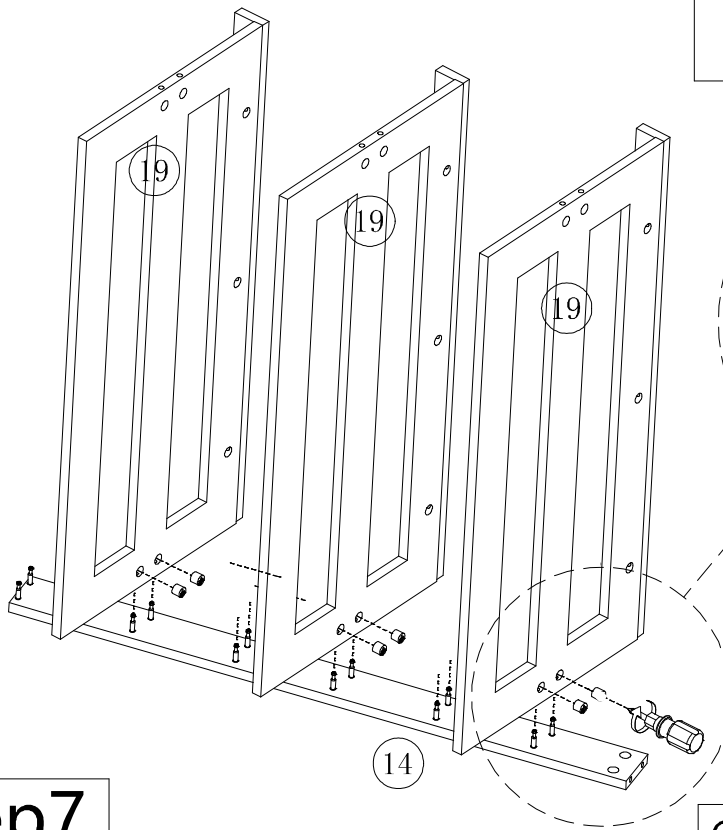

| Code | Diagram | count |
|----------|---------|----------|
| B | | 6 |

Step7

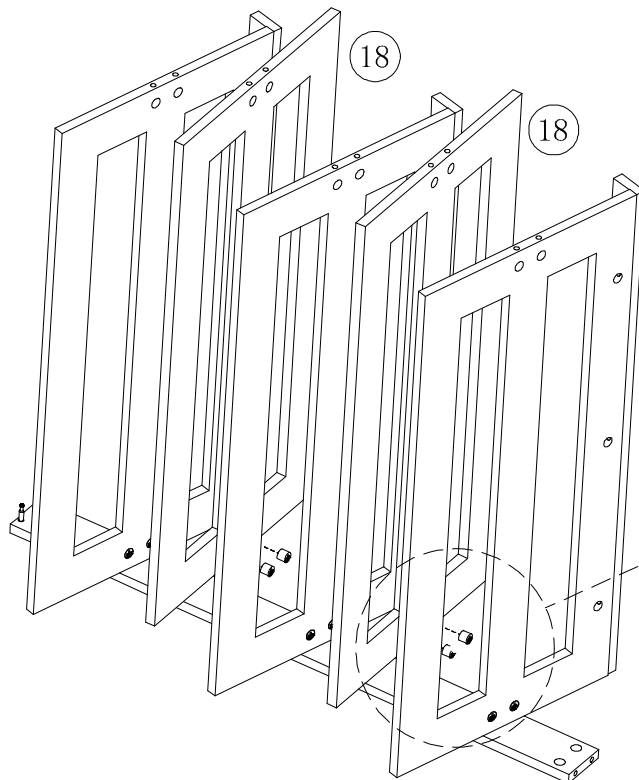

| Code | Diagram | count |
|----------|---------|----------|
| B | | 4 |

Step8

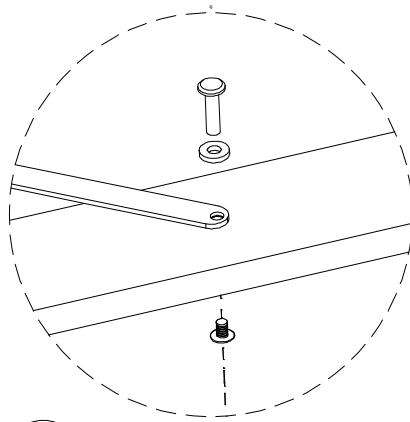

| Code | Diagram | count |
|------|------------|-------|
| C | | 1 |
| C | 5x17mm | 1 |
| C | | 1 |

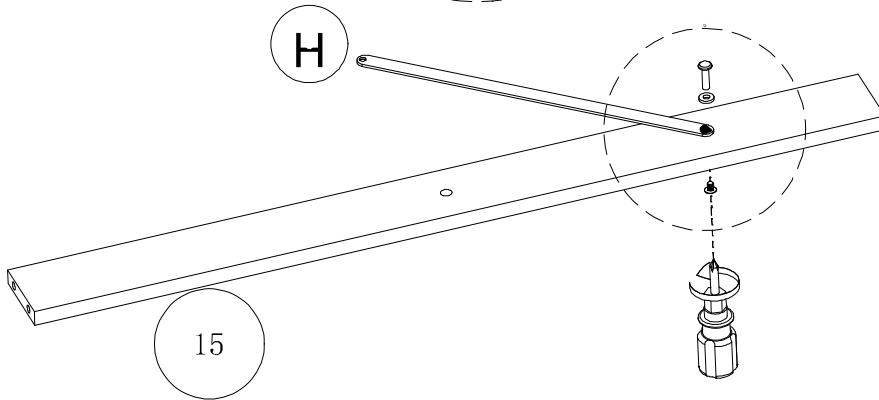

Step9

| Code | Diagram | count |
|------|---------|-------|
| B | | 2 |

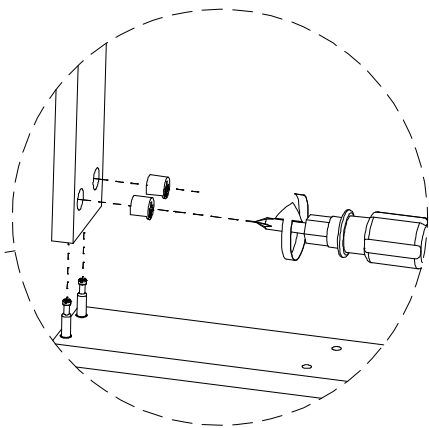
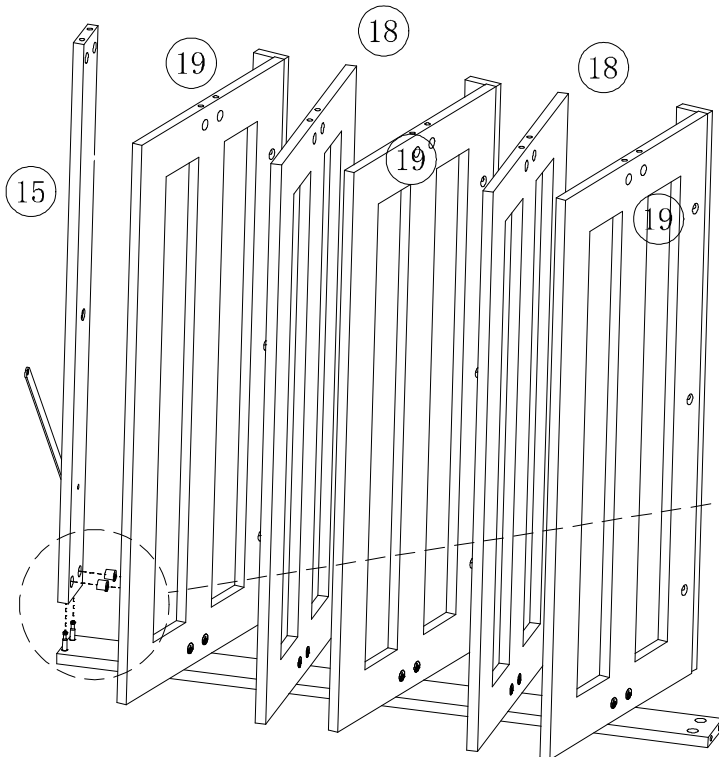

Step10

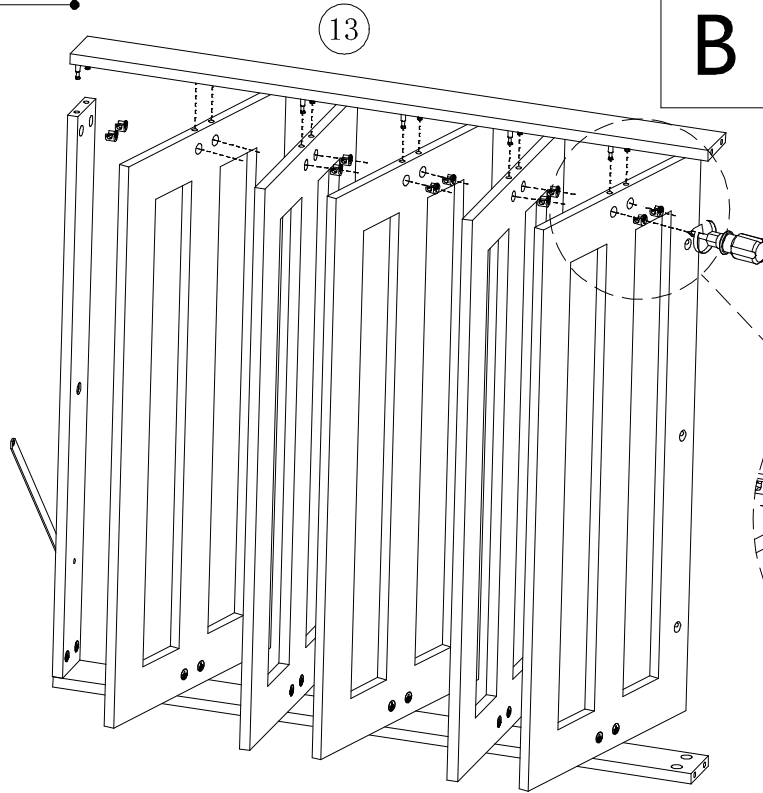

| Code | Diagram | count |
|----------|---------|-----------|
| B | | 12 |

Step11

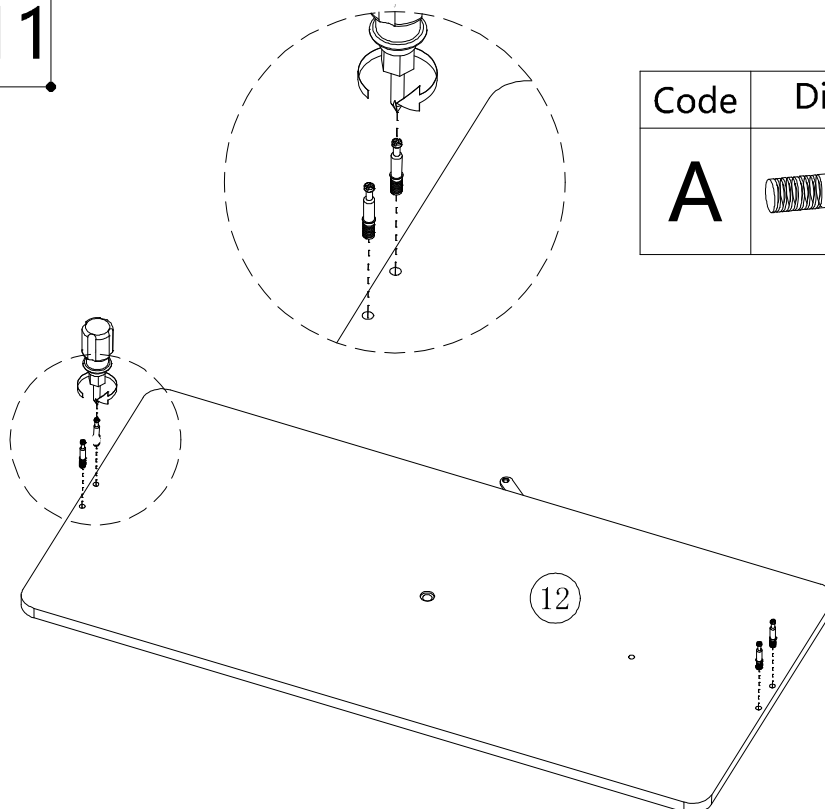

| Code | Diagram | count |
|----------|---------|----------|
| A | | 4 |

Step12

| Code | Diagram | count |
|----------|---|----------|
| B |  | 4 |

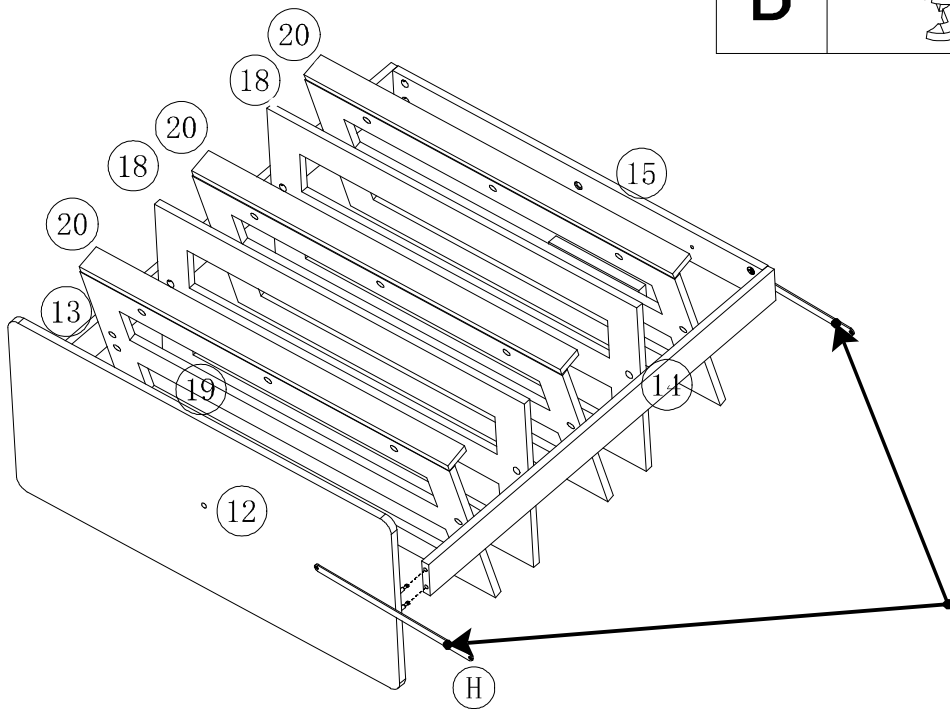

After installtion of 12 and15,the hole of H, keep the same directiton

Step13

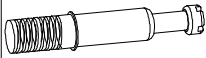
| Code | Diagram | count |
|----------|---|----------|
| A |  | 4 |

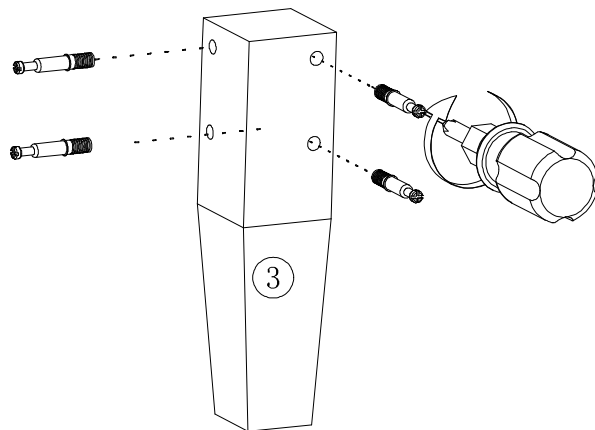

Repeat this installation four times

Step14

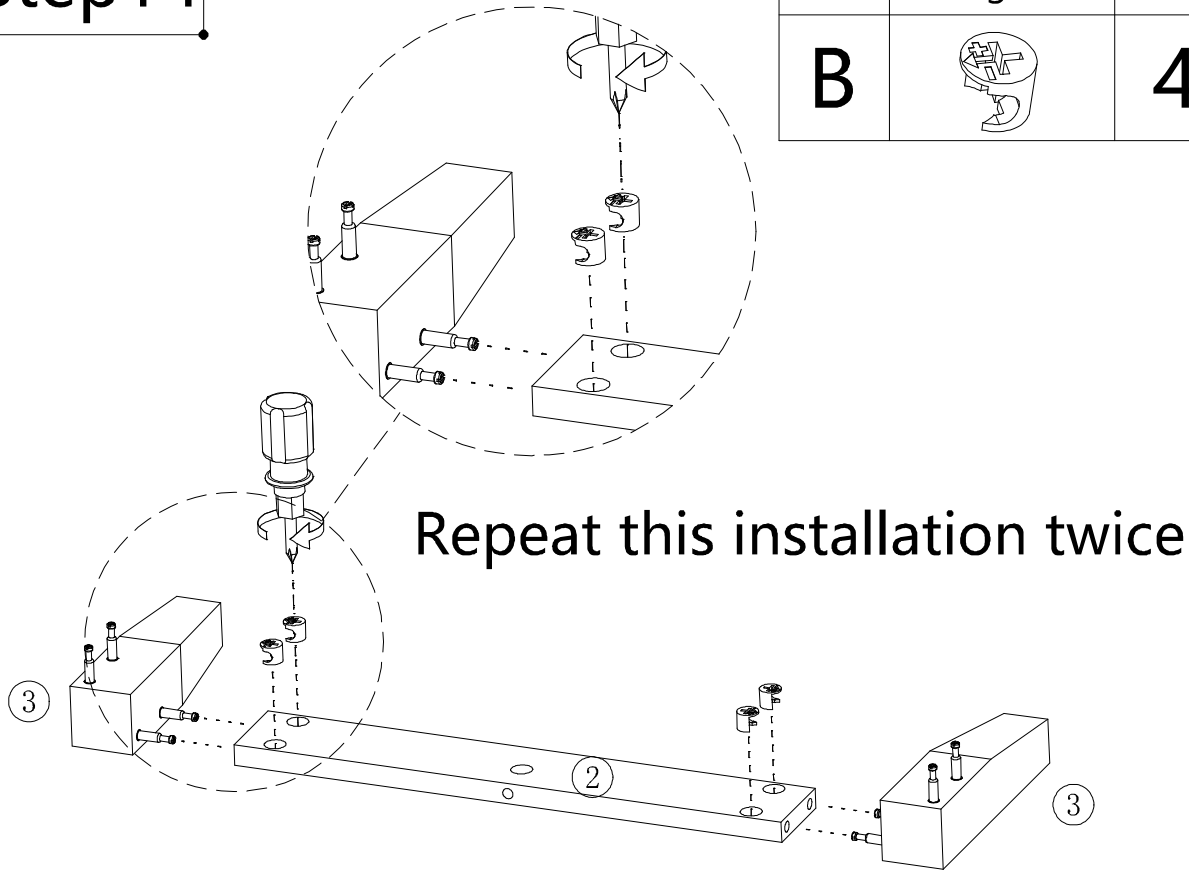

| Code | Diagram | count |
|----------|---------|----------|
| B | | 4 |

Step15

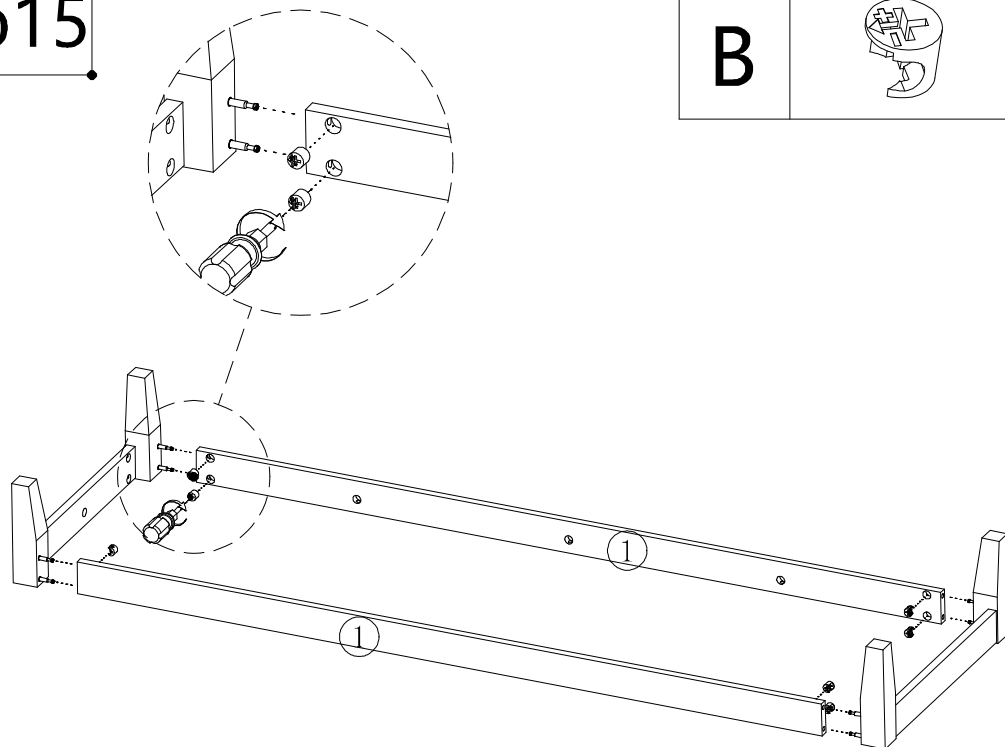

| Code | Diagram | count |
|----------|---------|----------|
| B | | 8 |

Step 16

Adjust height by rotation

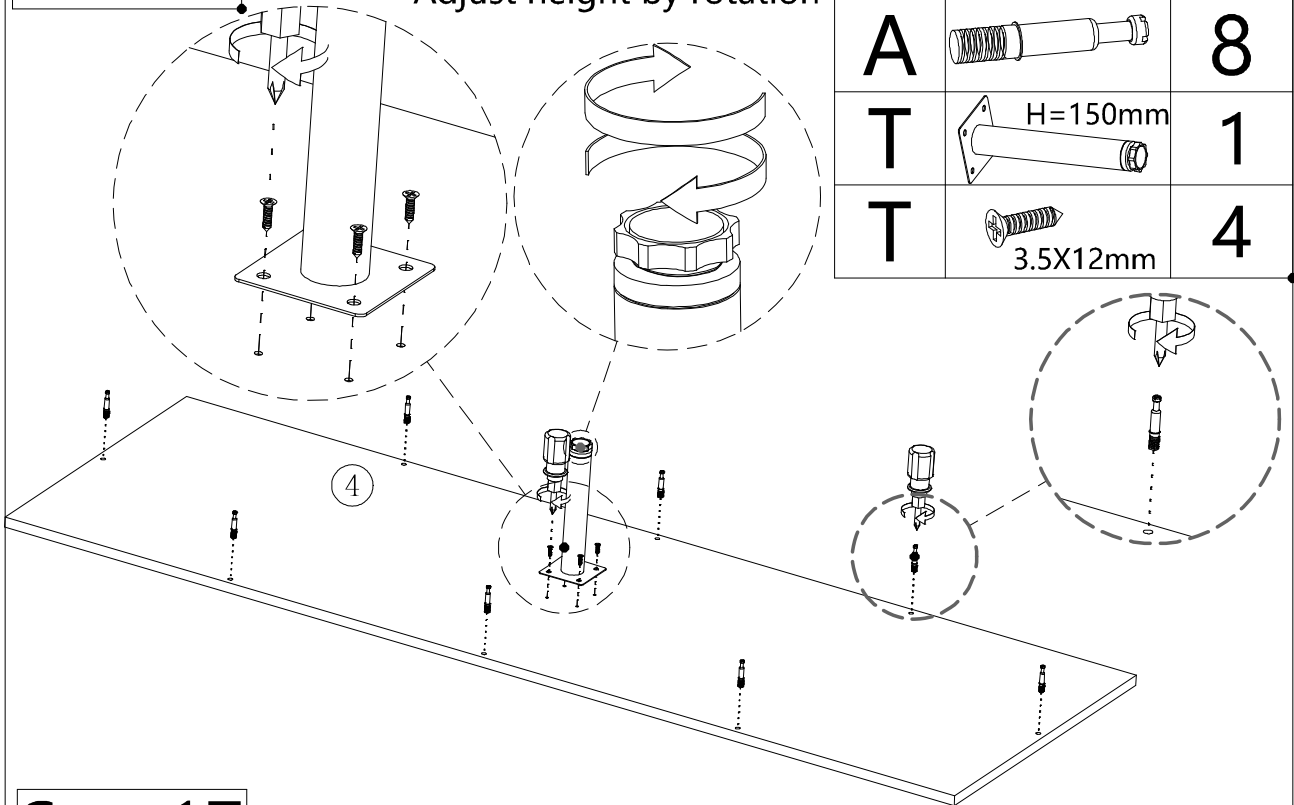

| Code | Diagram | count |
|------|---------|-------|
| A | | 8 |
| T | | 1 |
| T | | 4 |

Step 17

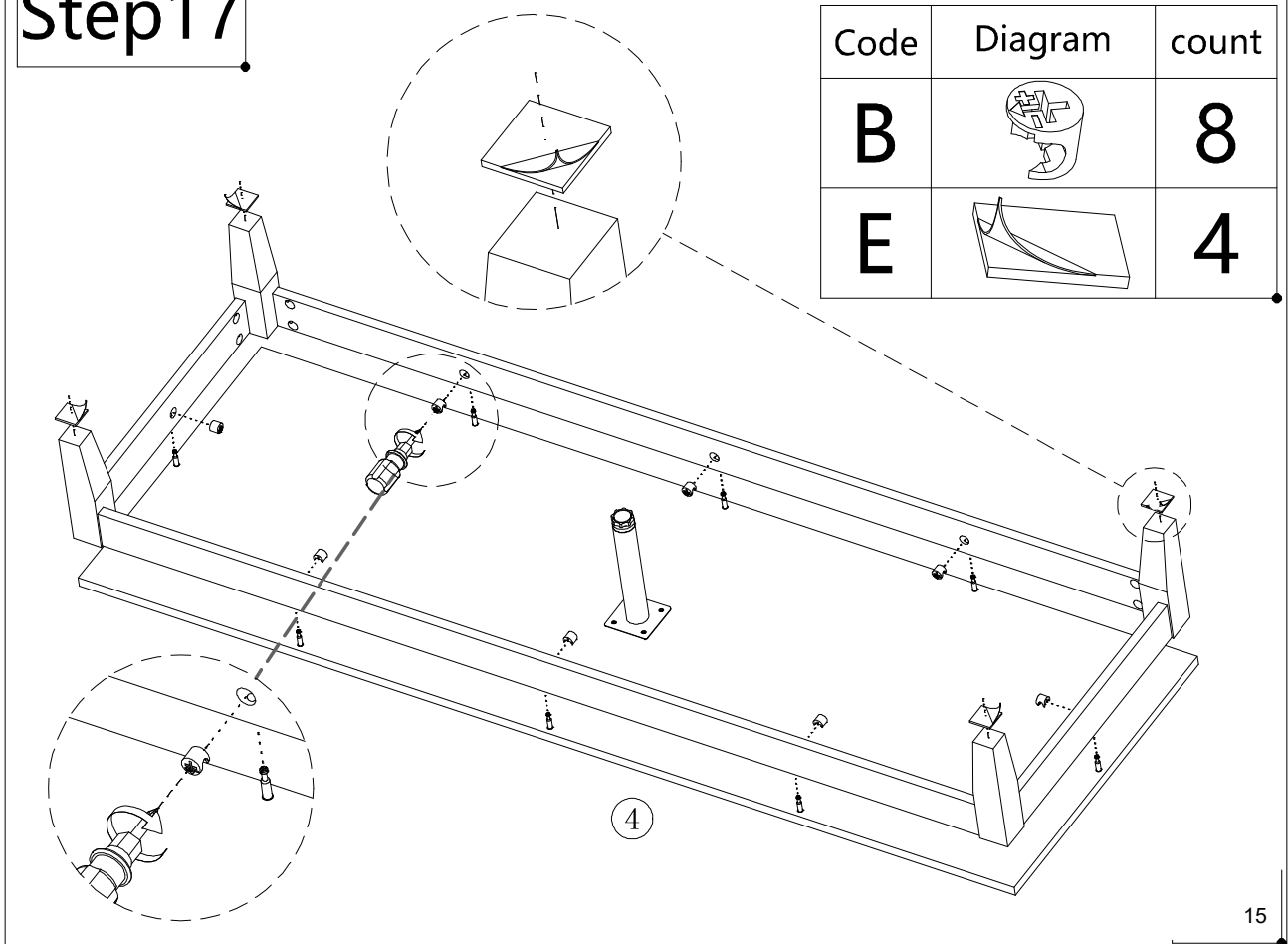



| Code | Diagram | count |
|------|---------|-------|
| B | | 8 |
| E | | 4 |

Step18

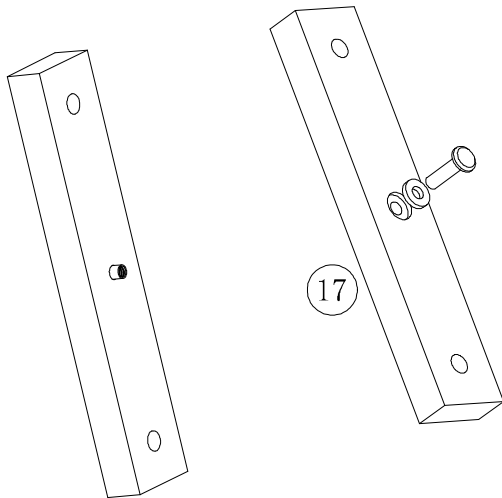
Repeat this installation twice

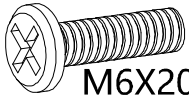

| Code | Diagram | count |
|------|---|-------|
| C |  | 1 |
| C |  5x17mm | 1 |

| Code | Diagram | count |
|------|---|-------|
| F |  M6X20 | 2 |

Step19

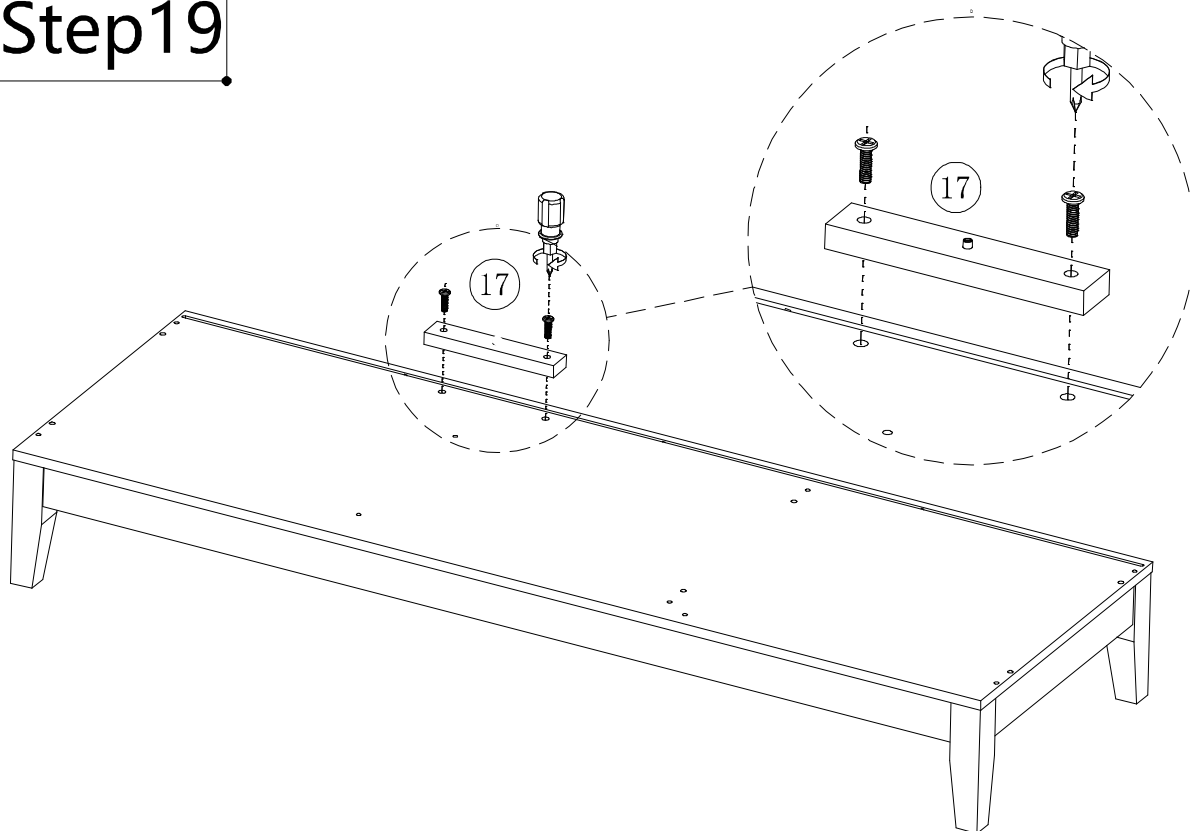

Drawer rail breakdown diagram

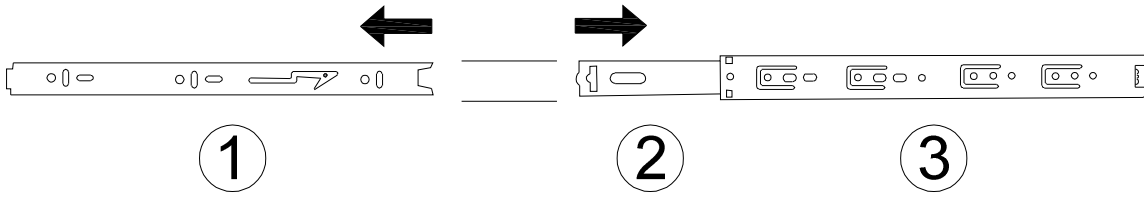

① Dismantle the schematic diagram

Step 1 : Pull the rails apart

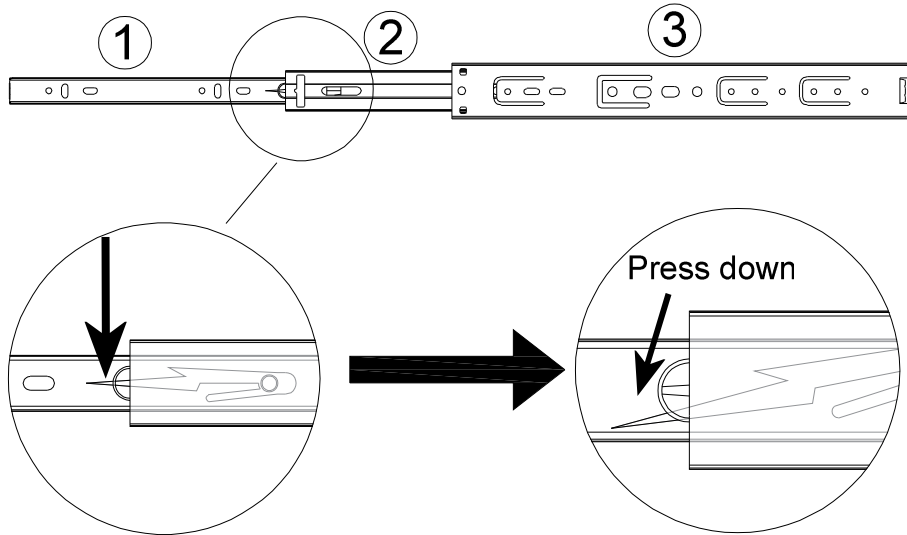

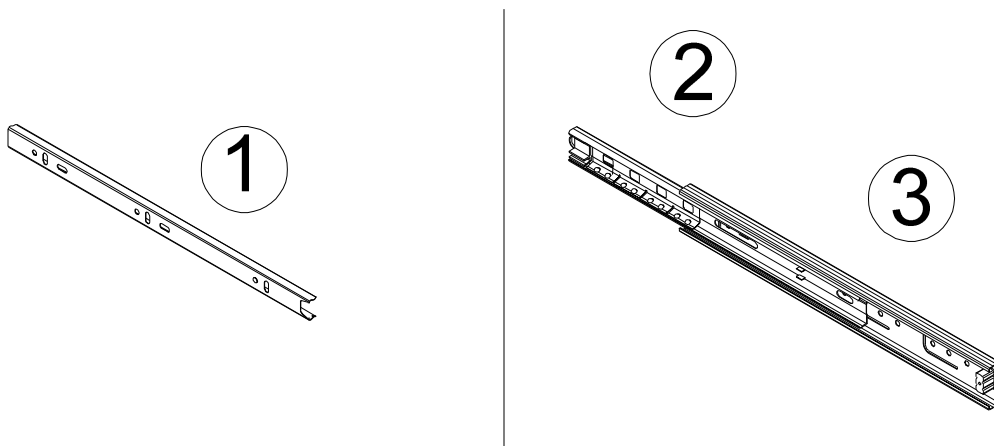

Step 2 : Press the nylon button and pull out ①.

Drawer rail decomposition completed schematic diagram



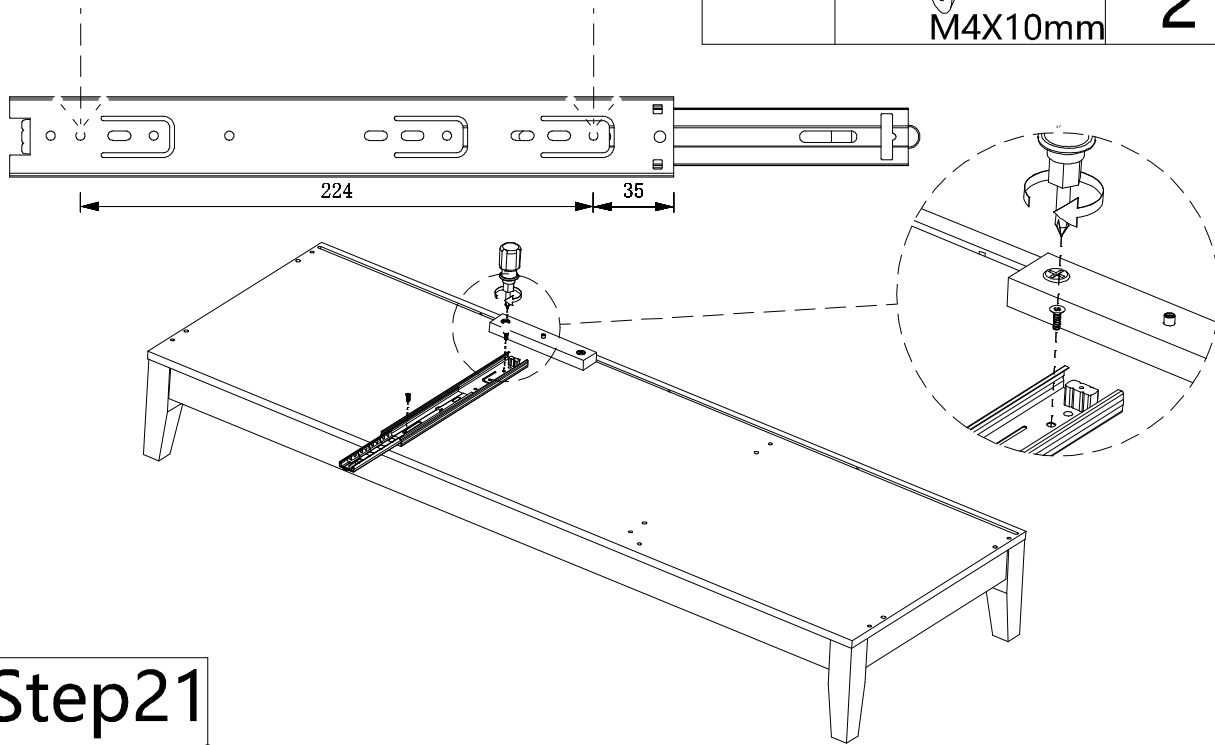

Step20

| Code | Diagram | count |
|------|--|-------|
| I |  | 1 |
| |  M4X10mm | 2 |

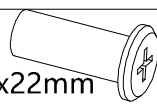

Step21

| Code | Diagram | count |
|------|---|-------|
| P |  8x22mm | 1 |
| P |  | 1 |

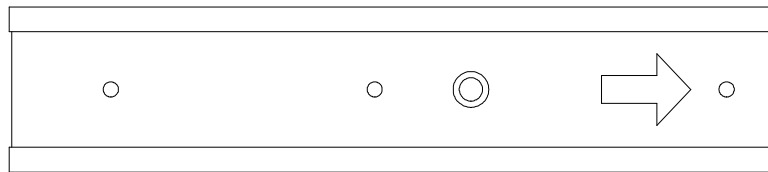

Repeat this installation twice

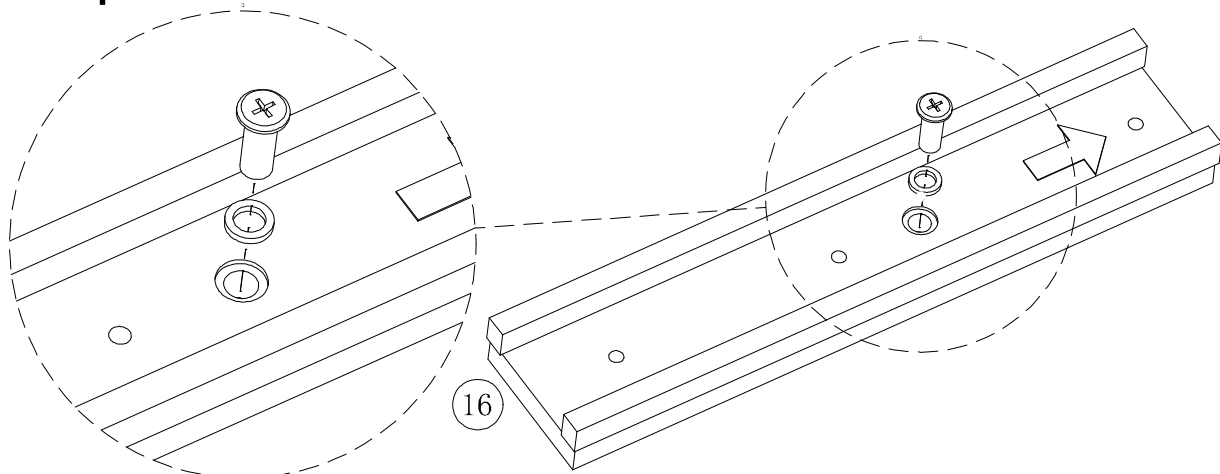

Step22

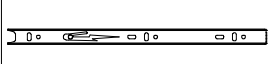
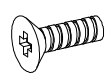
| Code | Diagram | count |
|------|---|-------|
| I |  | 1 |
| |  M4X10mm | 3 |

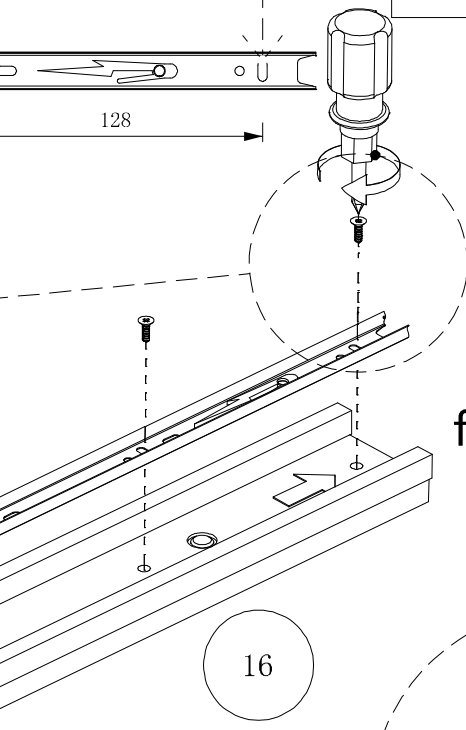
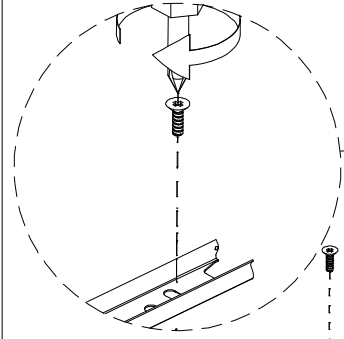
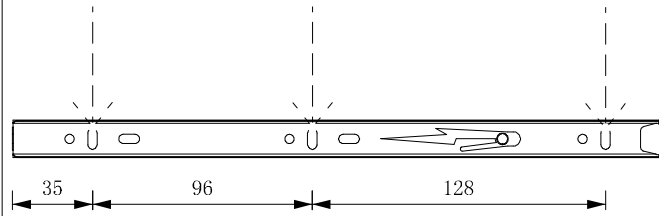

Repeat this installation twice

frontend

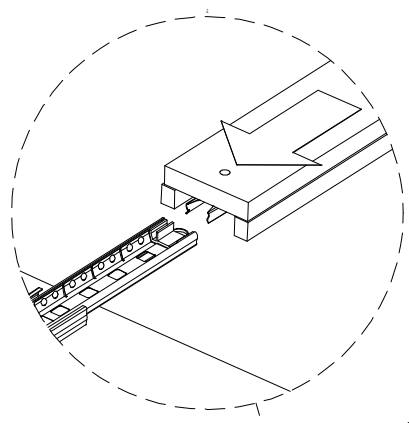

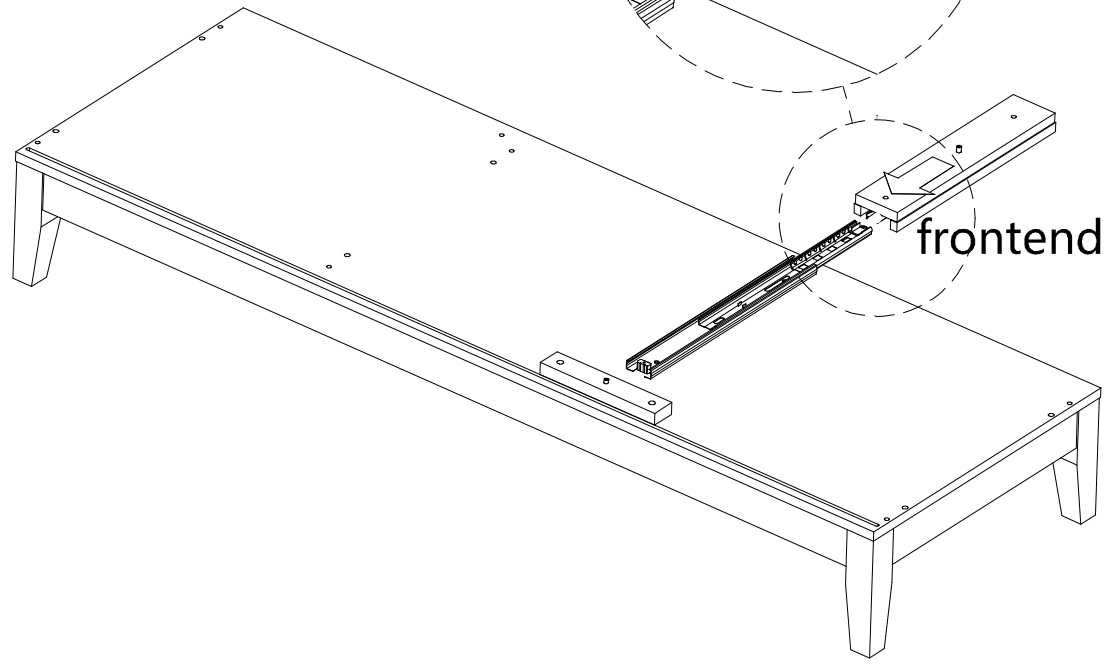

Step23



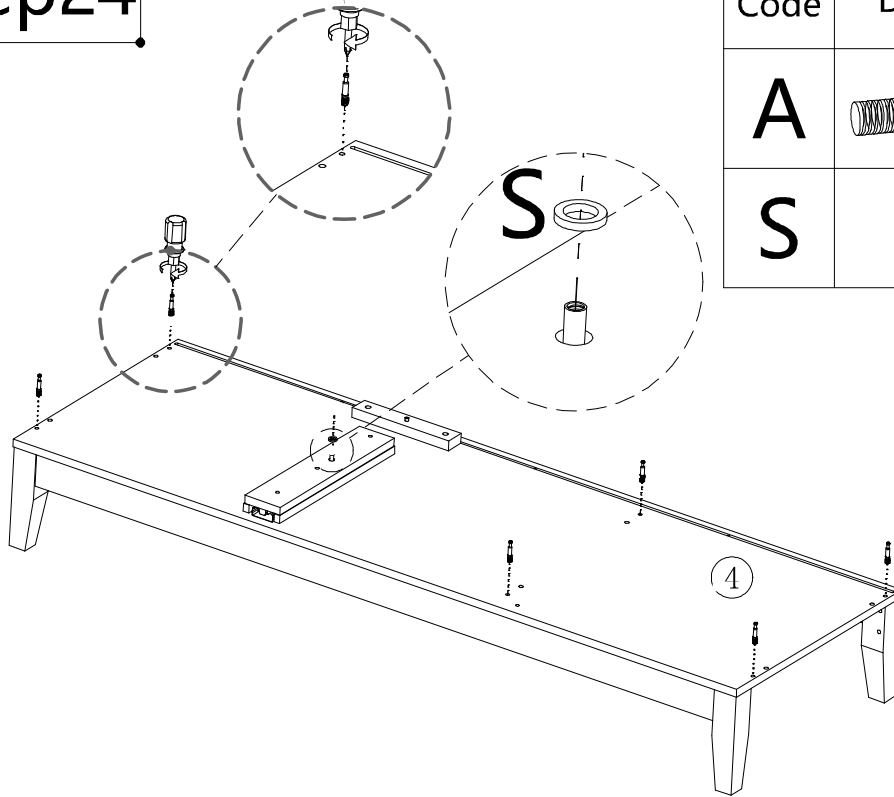

Step24

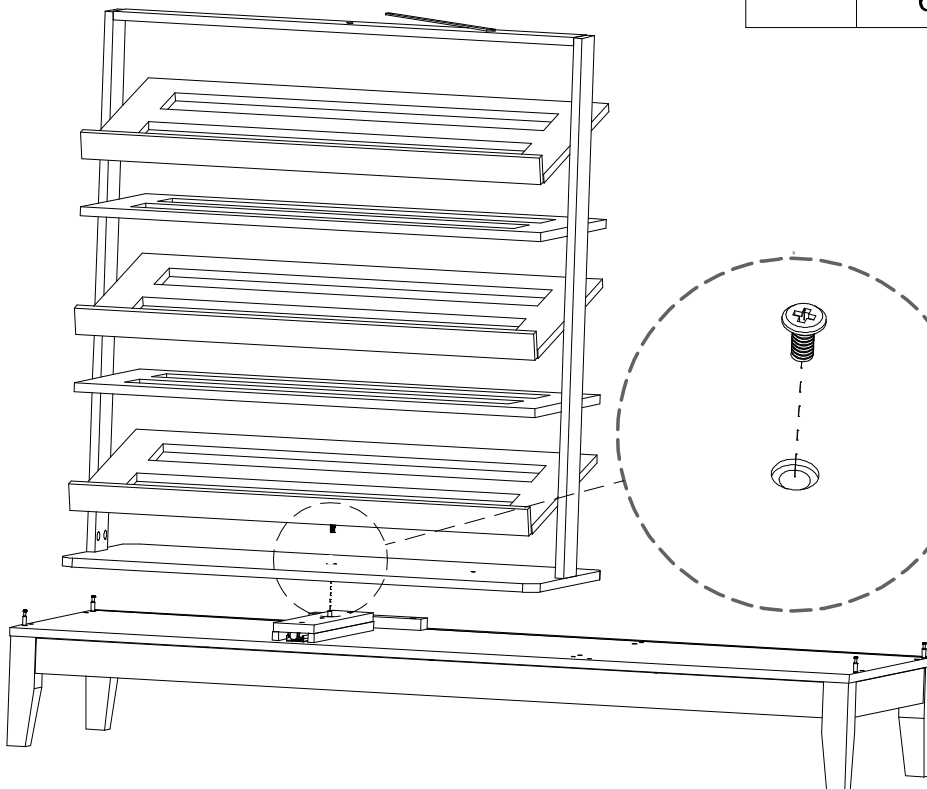

| Code | Diagram | count |
|------|---|-------|
| A |  | 6 |
| S |  | 1 |

Step25



| Code | Diagram | count |
|------|---|-------|
| P |  6X10mm | 1 |

Step26

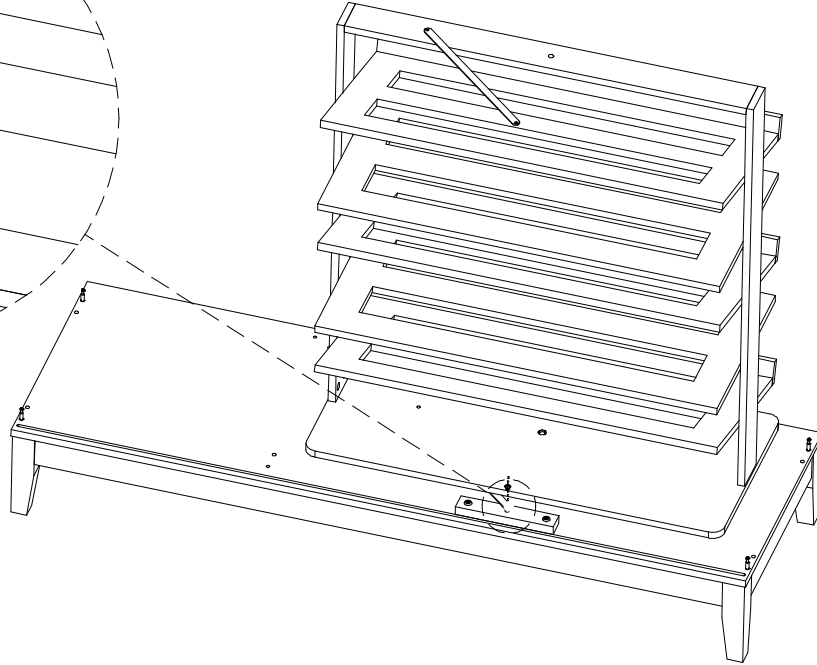
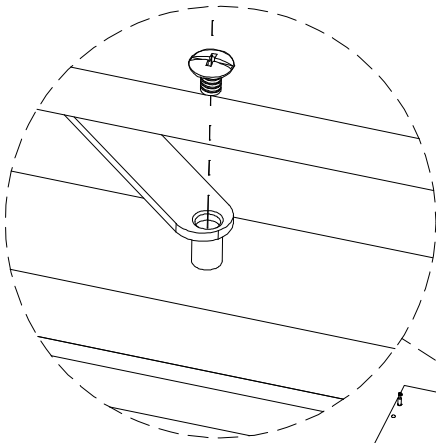

| Code | Diagram | count |
|----------|---|----------|
| C |  | 1 |

Step27

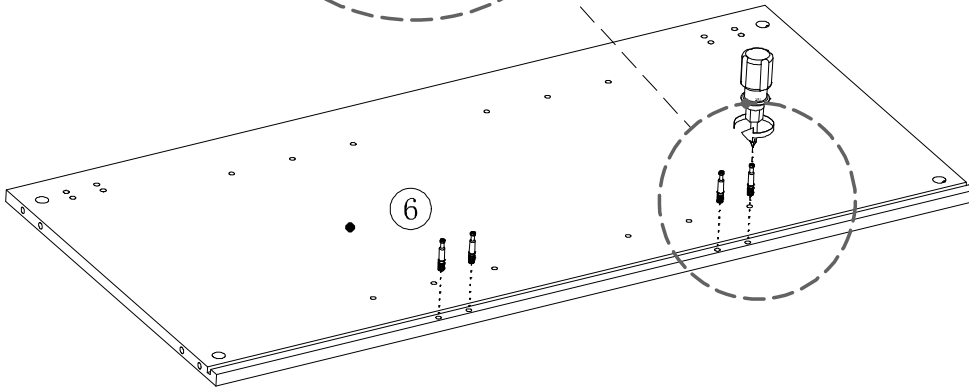
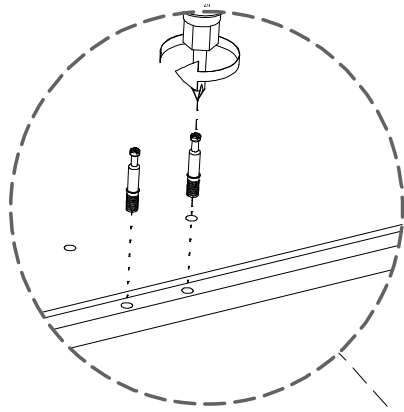

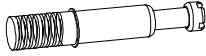
| Code | Diagram | count |
|----------|---|----------|
| A |  | 4 |

Step28

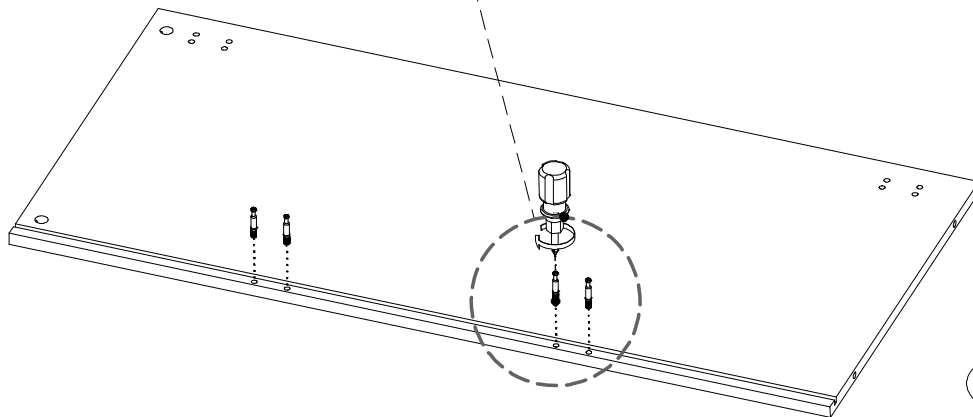
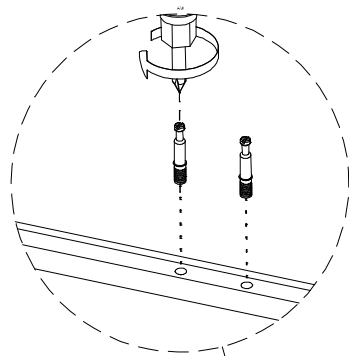

5

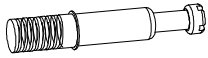
| Code | Diagram | count |
|----------|---|----------|
| A |  | 4 |

Step29

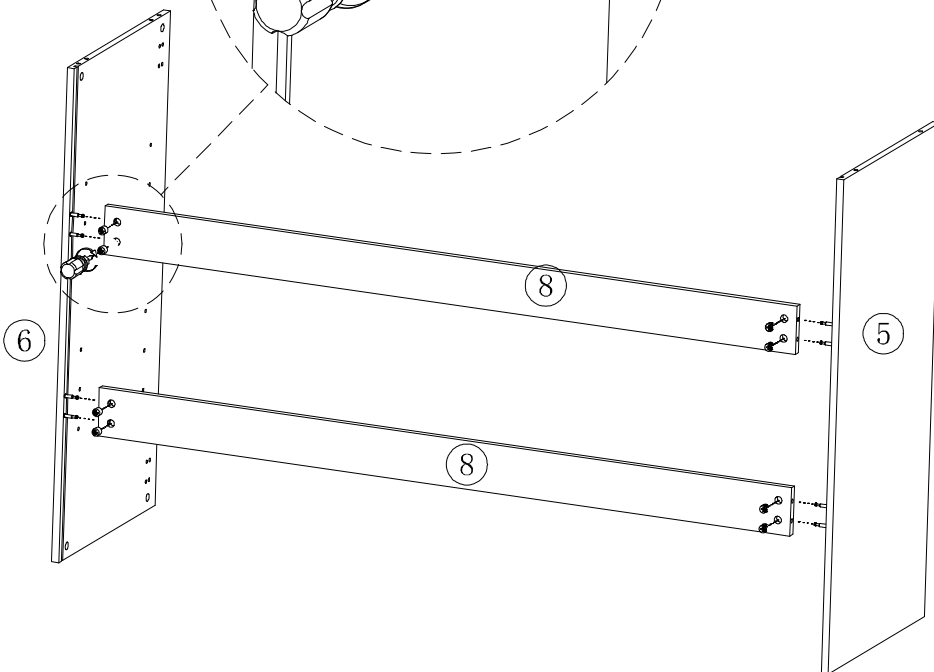
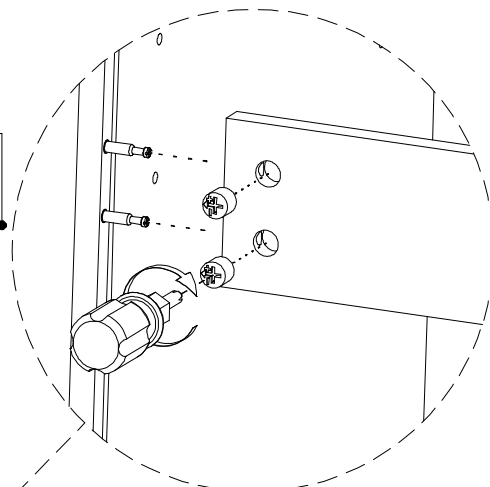

6

8

5

8



| Code | Diagram | count |
|----------|---|----------|
| B |  | 8 |

Step30

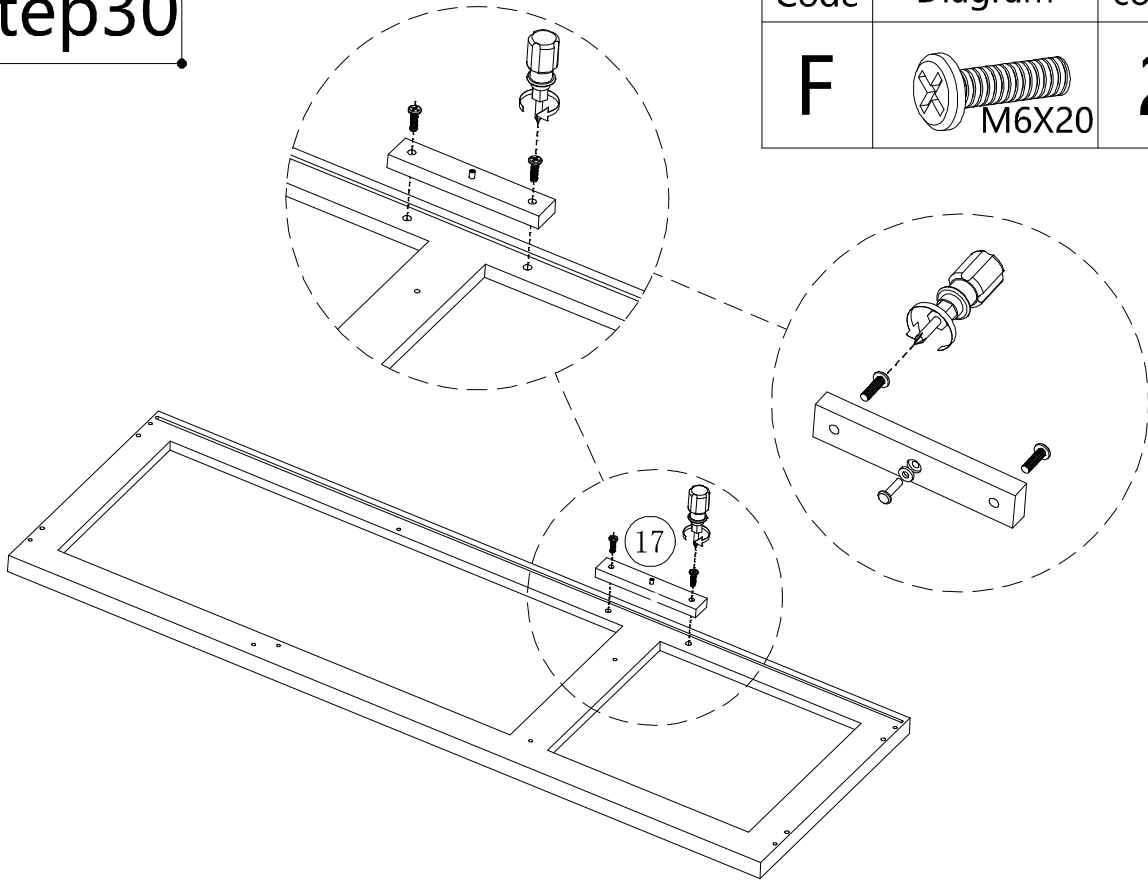
| Code | Diagram | count |
|------|---|-------|
| F |  M6X20 | 2 |



Step31

| Code | Diagram | count |
|------|---|-------|
| I |  | 1 |
| |  M4X10mm | 2 |

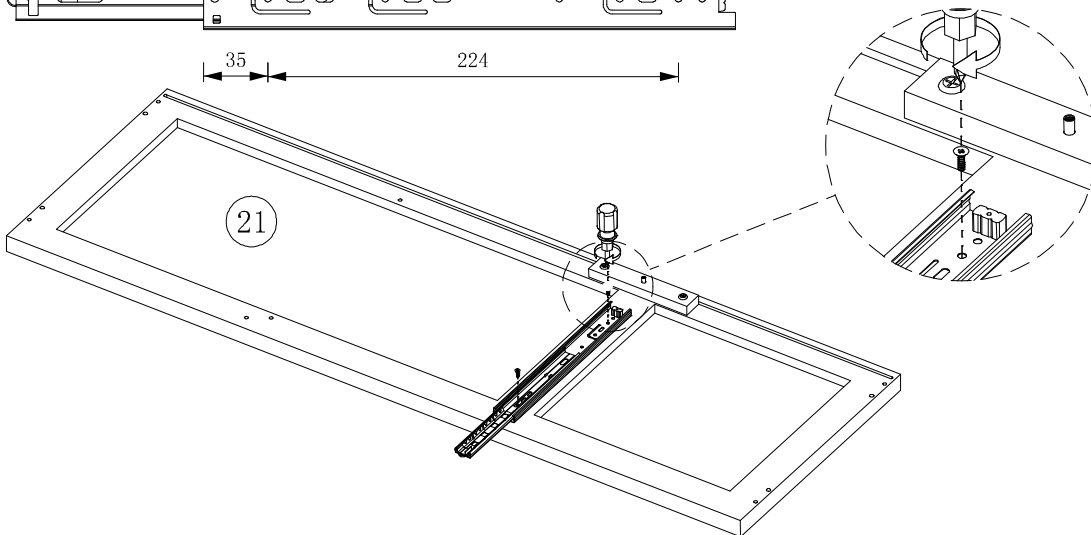
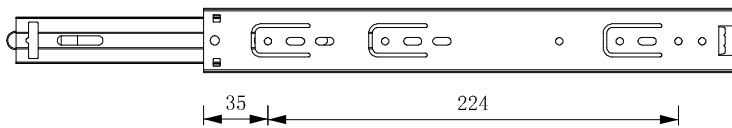

Step32

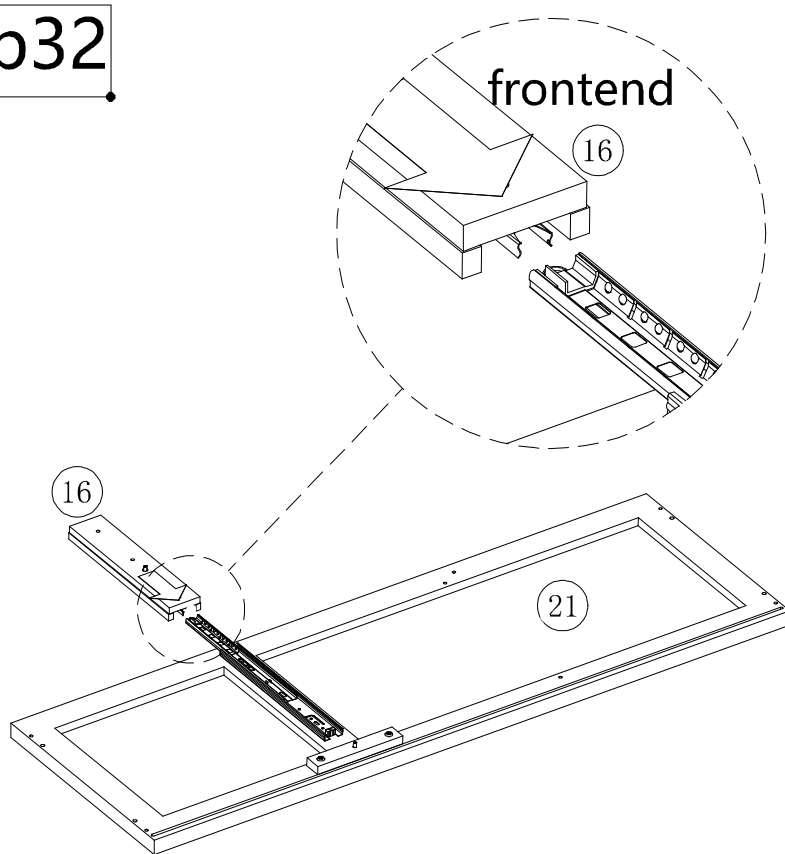

Step33

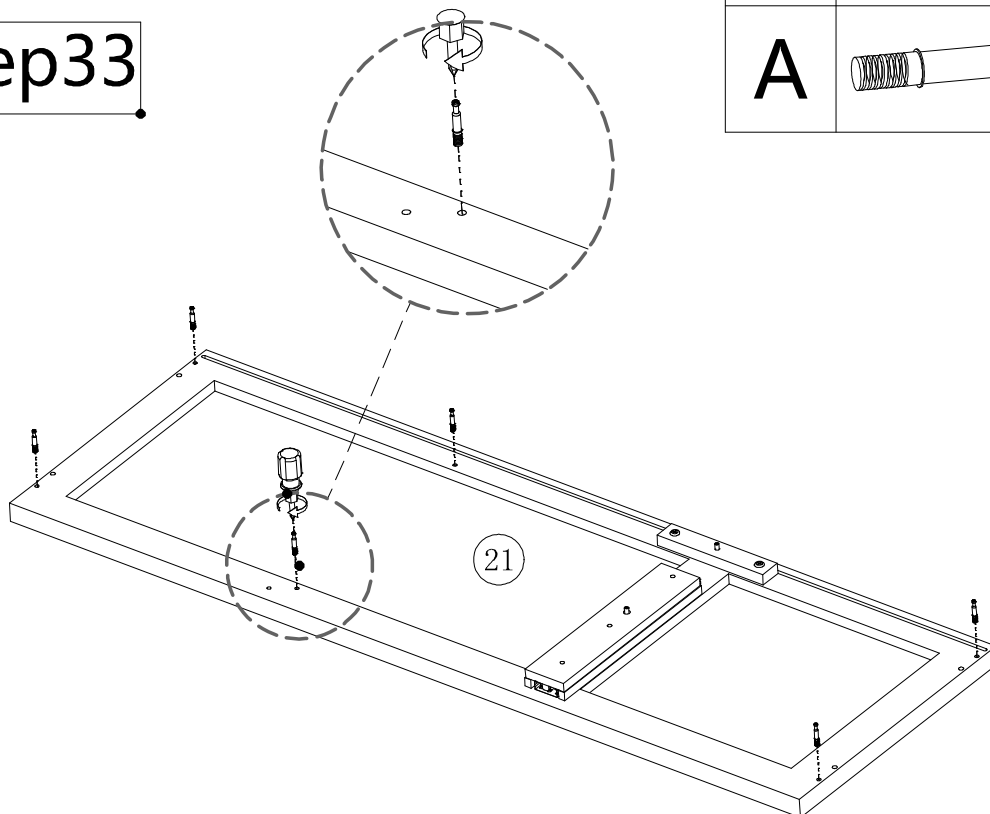

| Code | Diagram | count |
|------|---|-------|
| A |  | 6 |

Step34

| Code | Diagram | count |
|------|---|-------|
| D |  | 6 |

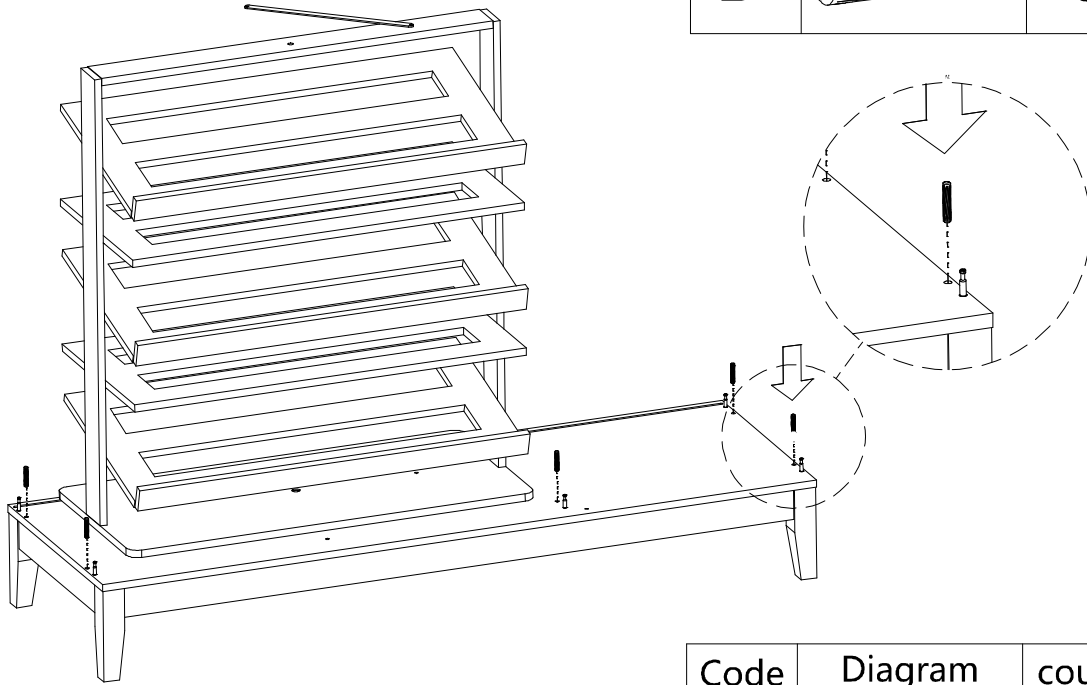

| Code | Diagram | count |
|------|---|-------|
| B |  | 4 |

Step35

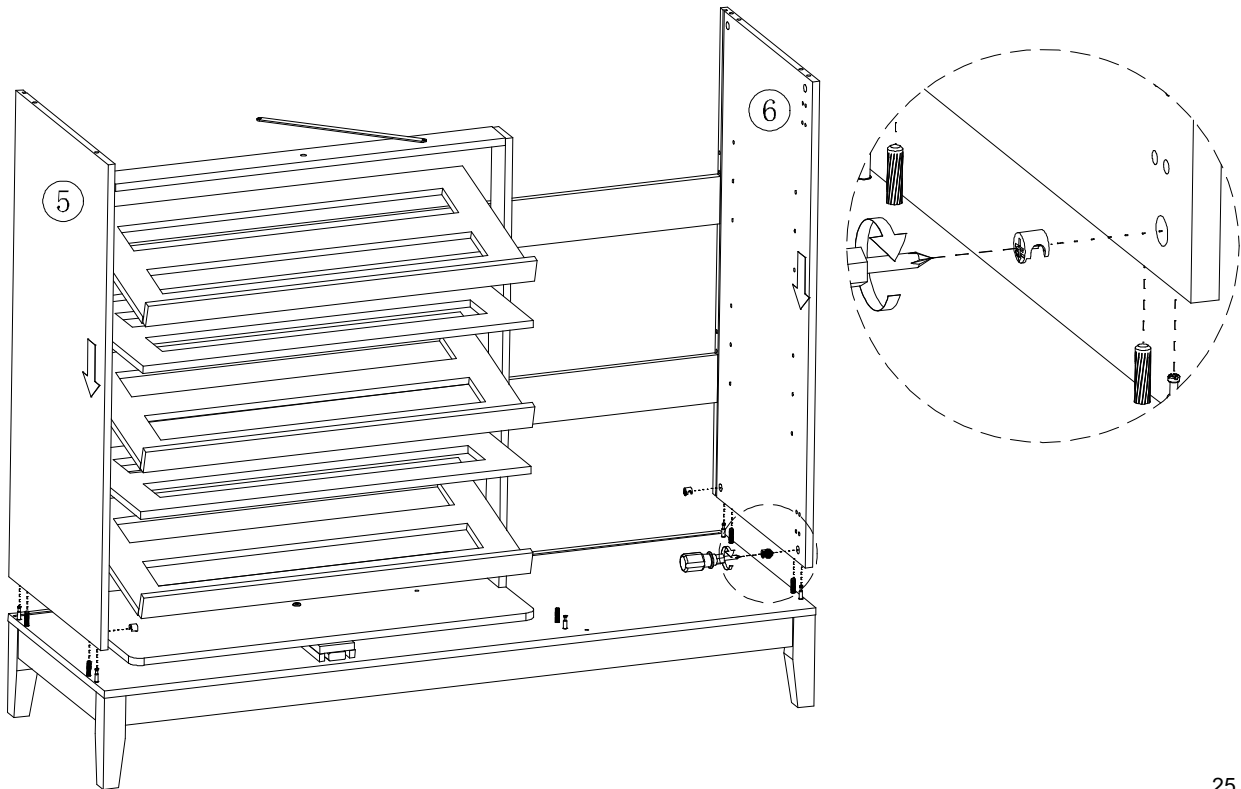

Step36

| Code | Diagram | count |
|----------|---|----------|
| B |  | 2 |

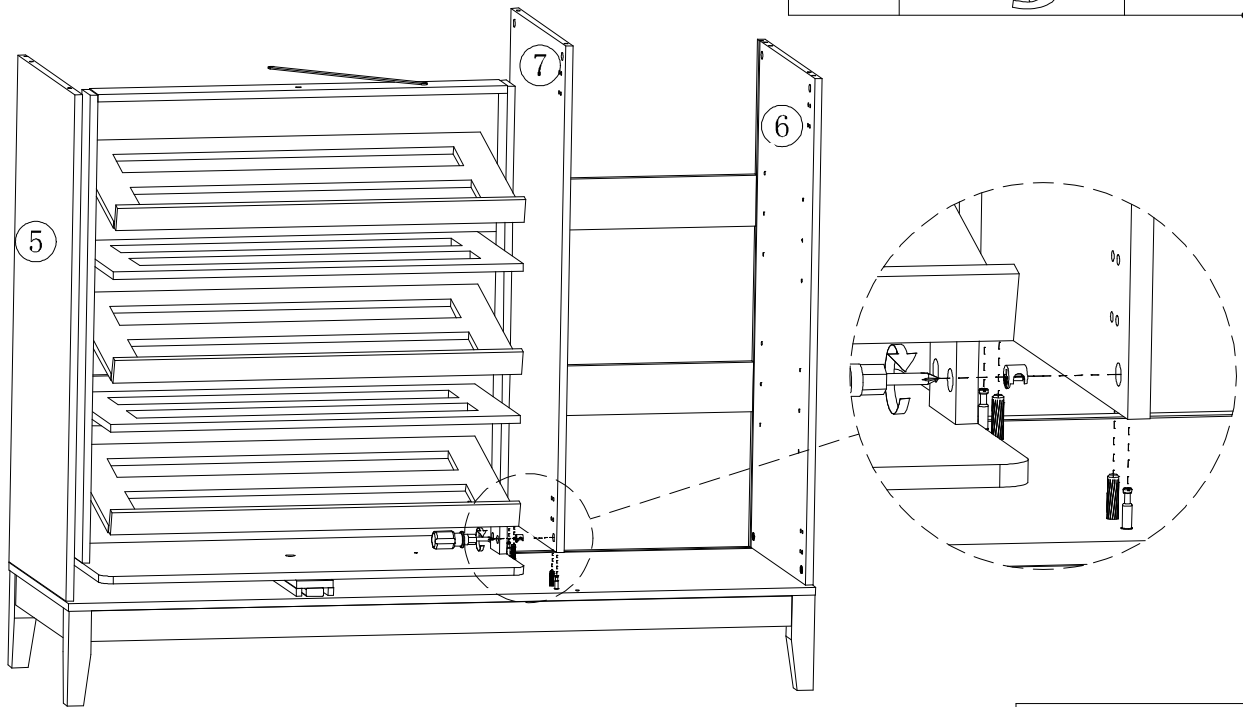

Step37

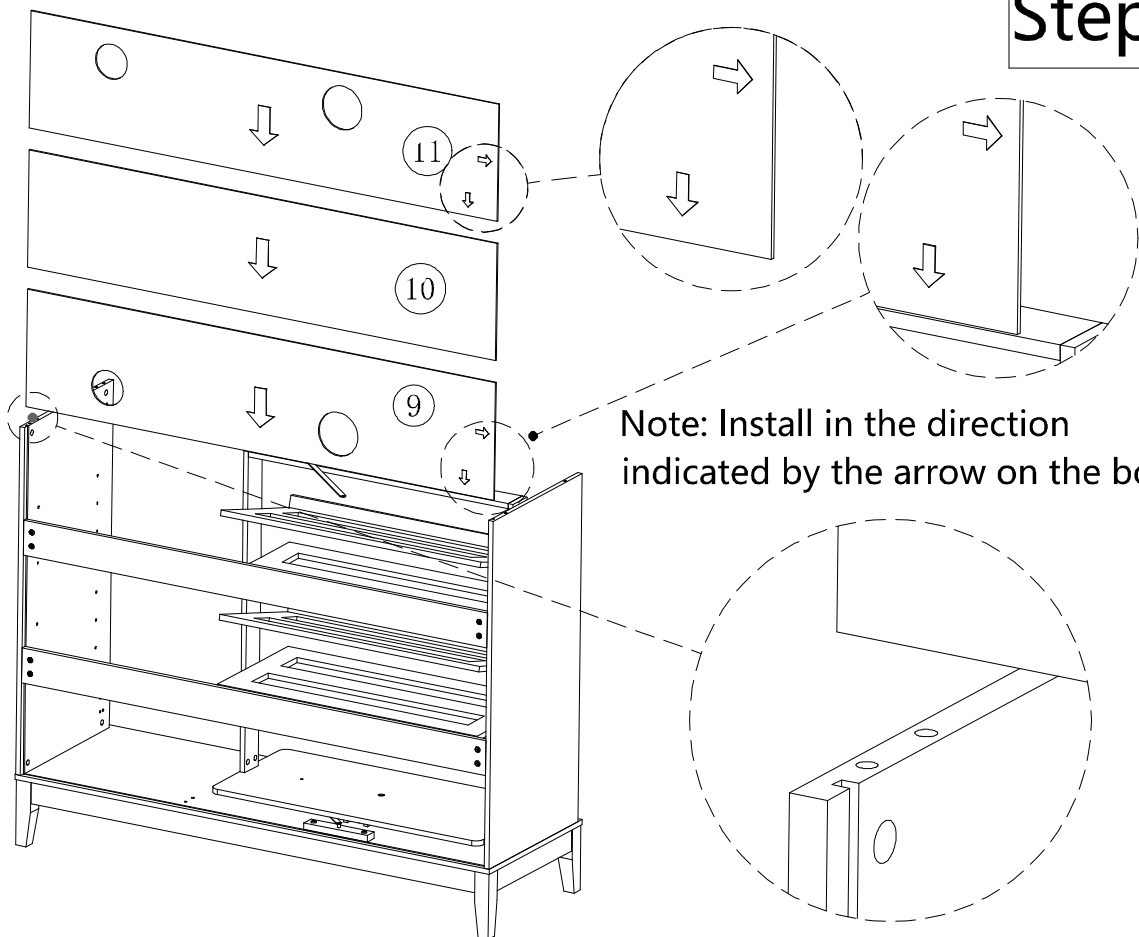

Step38

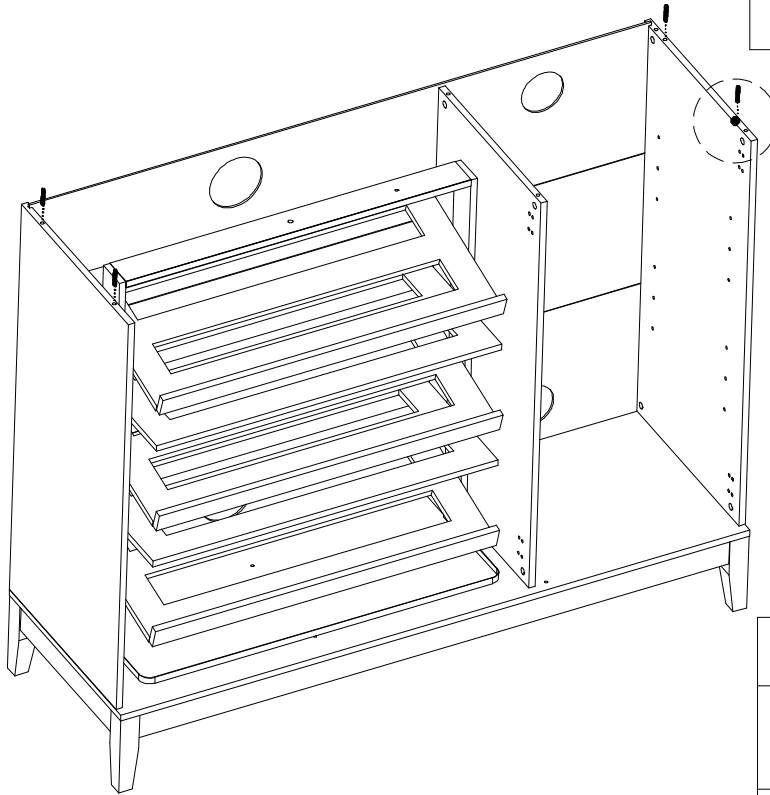

| Code | Diagram | count |
|------|---|-------|
| D |  | 4 |

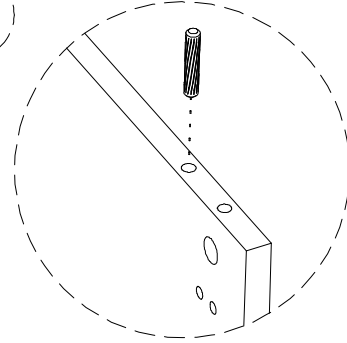

Step39

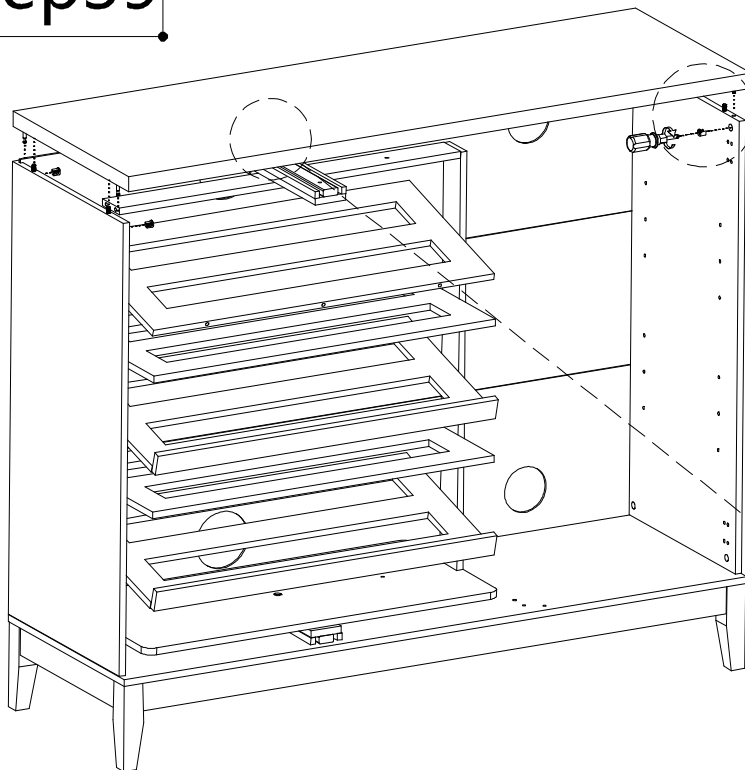

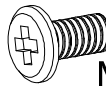
| Code | Diagram | count |
|------|---|-------|
| B |  | 1 |
| P |  M6X10 | 1 |

Step1

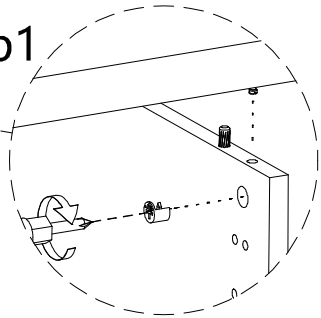

Step2

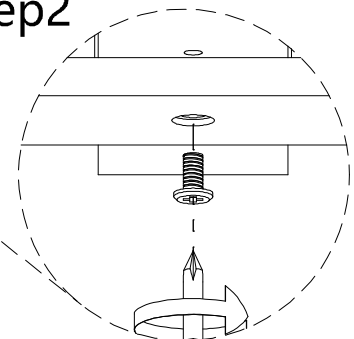

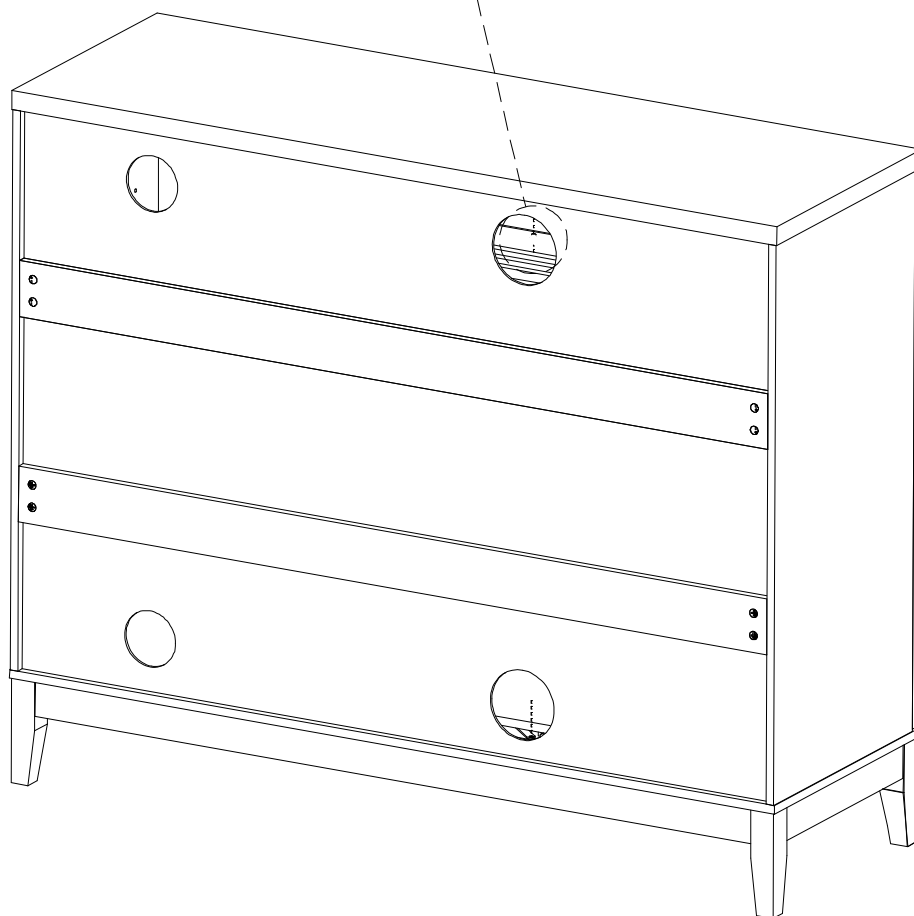
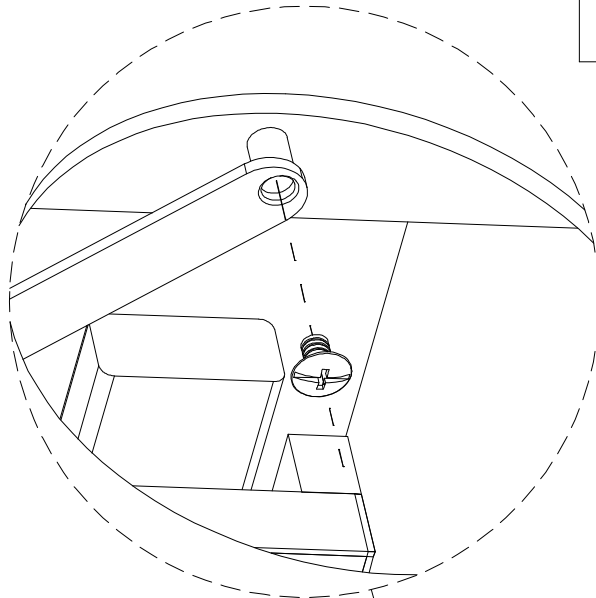

Step40

| Code | Diagram | count |
|------|---|-------|
| C |  | 1 |



Step41

| Code | Diagram | count |
|------|--|-------|
| J |  | 12 |
| |  3x16mm | 12 |

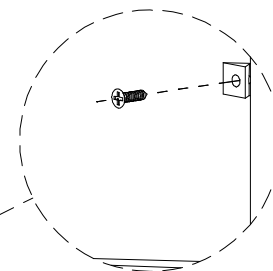
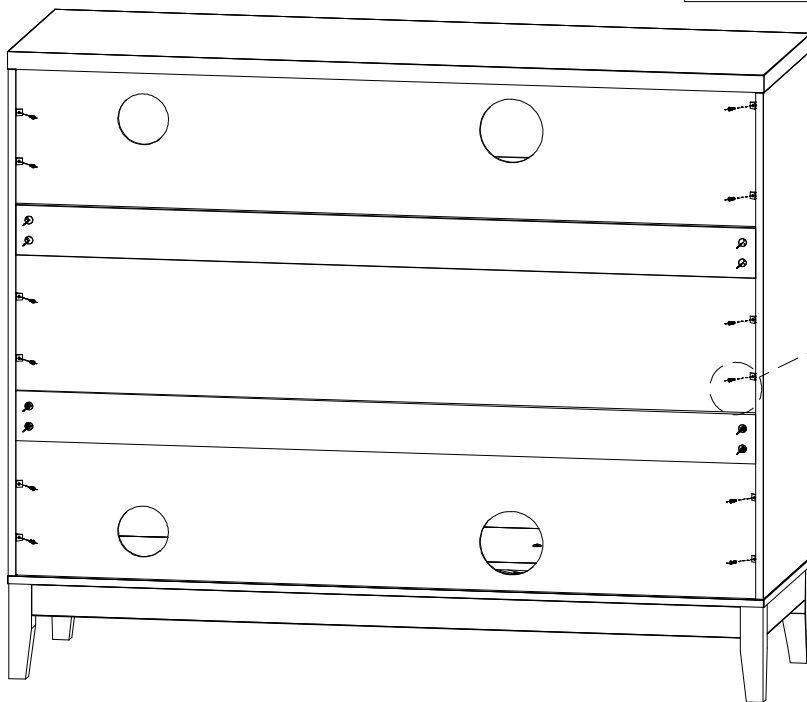

Step42

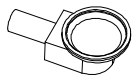
| Code | Diagram | count |
|------|---|-------|
| M |  | 8 |

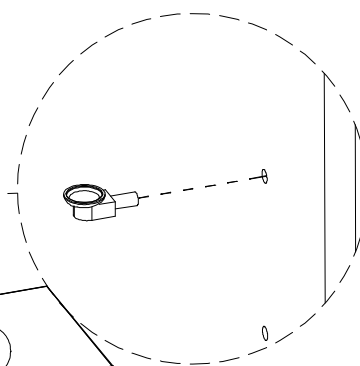
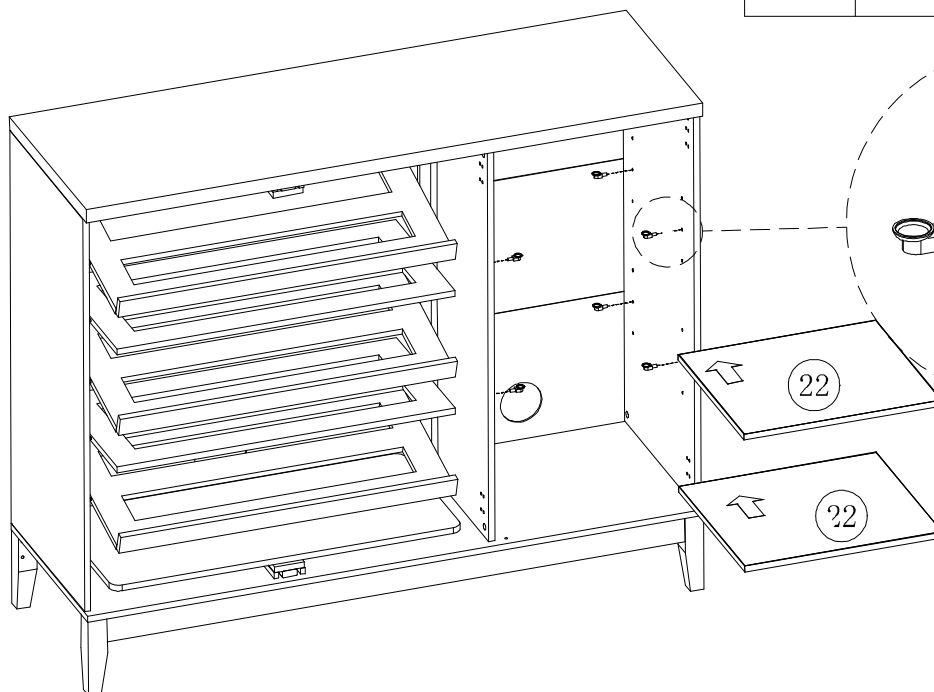

Step43

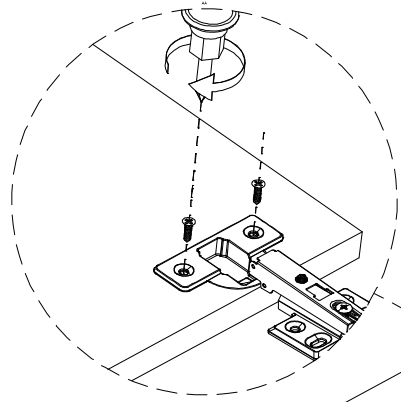

| Code | Diagram | count |
|------|----------|-------|
| K | | 2 |
| | 3.5X14mm | 4 |

Repeat this installation twice

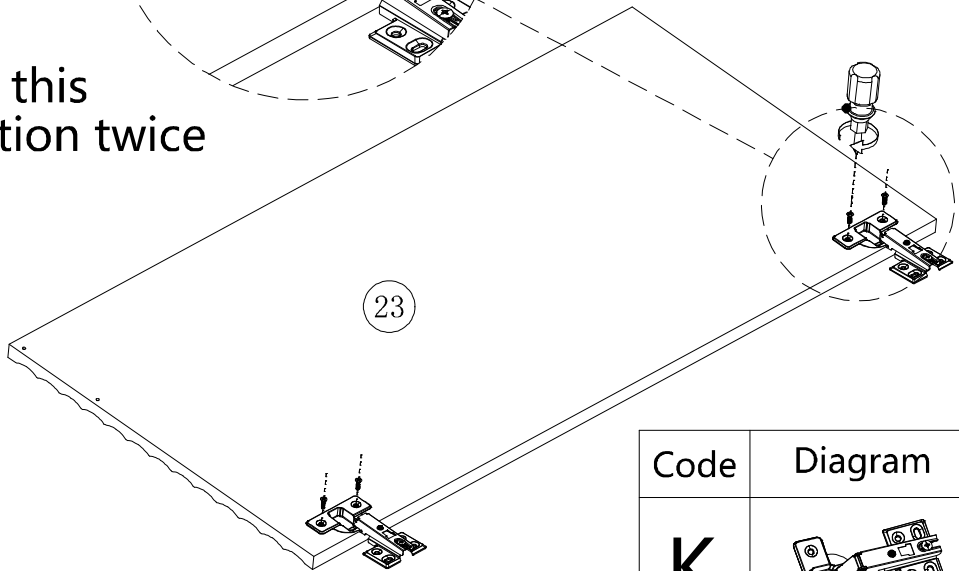

| Code | Diagram | count |
|------|----------|-------|
| K | | 2 |
| | 3.5X14mm | 4 |

Step44

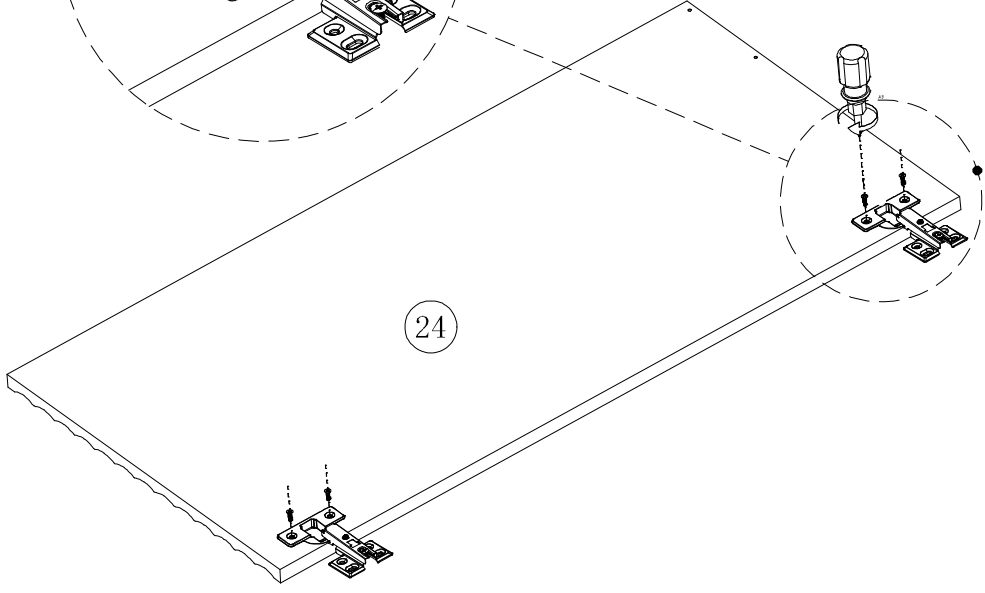
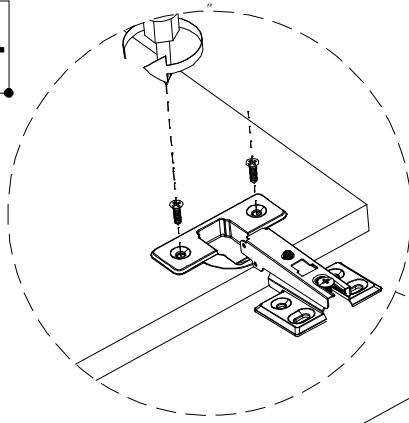

Step45

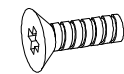
| Code | Diagram | count |
|----------|---|-----------|
| K |  M4X8mm | 16 |

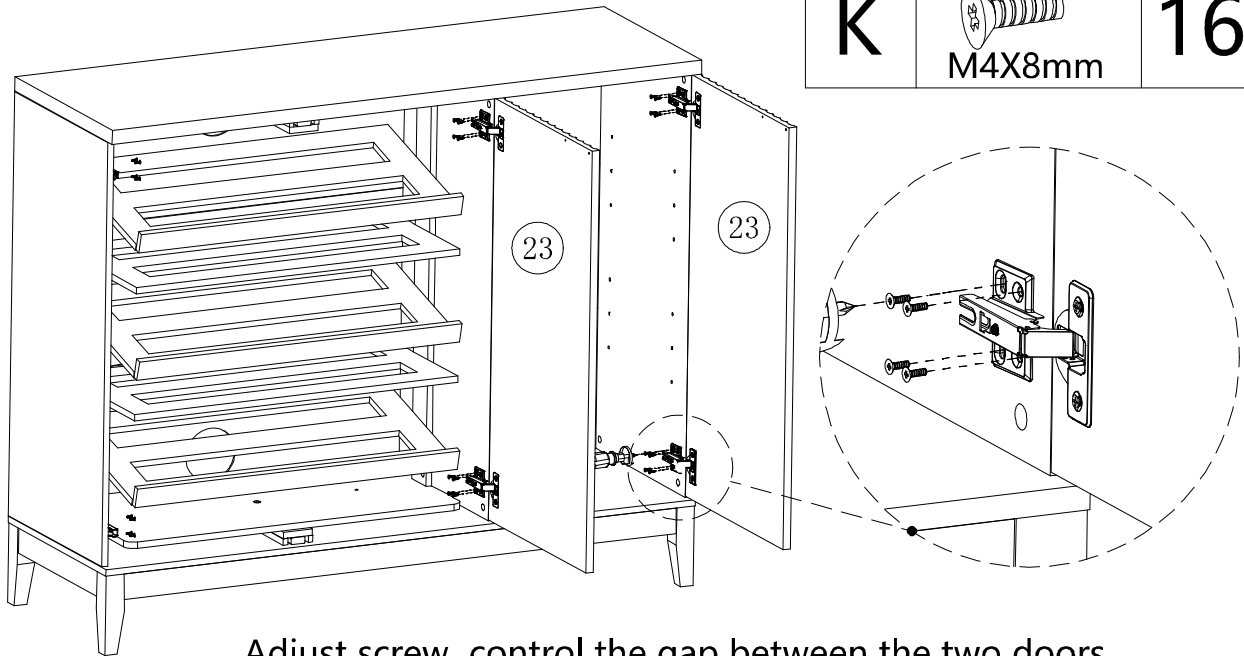

Adjust screw control the gap between the two doors

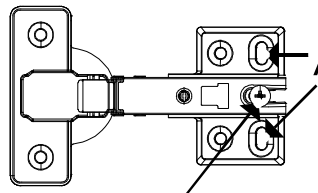

Adjust hole control the up and down height of the door

Adjust screw control the gap between the door and the board

Step46

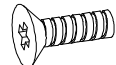
| Code | Diagram | count |
|----------|---|----------|
| K |  M4X8mm | 8 |

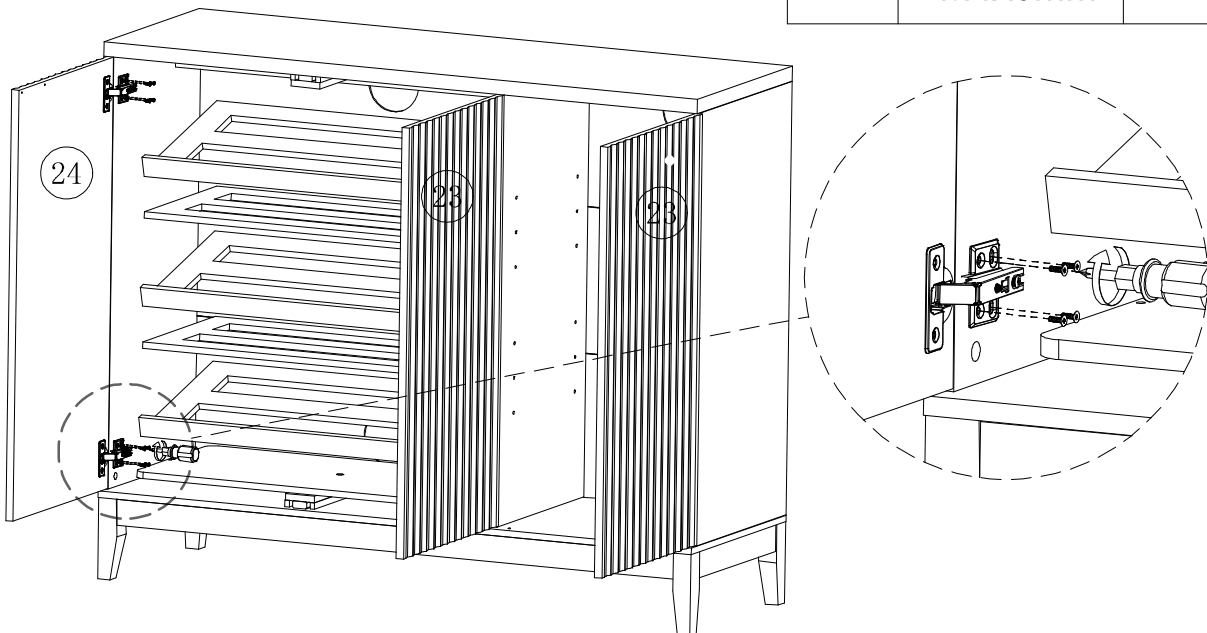

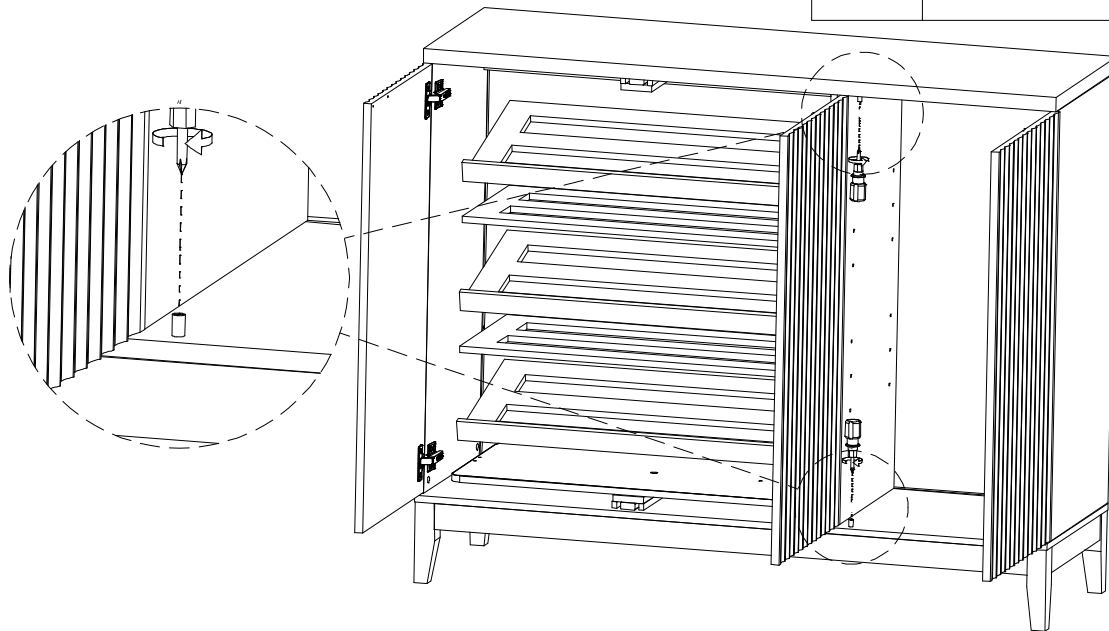

Step47

| Code | Diagram | count |
|------|---|-------|
| L |  | 2 |



Step48

| Code | Diagram | count |
|------|---|-------|
| G |  | 3 |
| |  3.5x12mm | 6 |

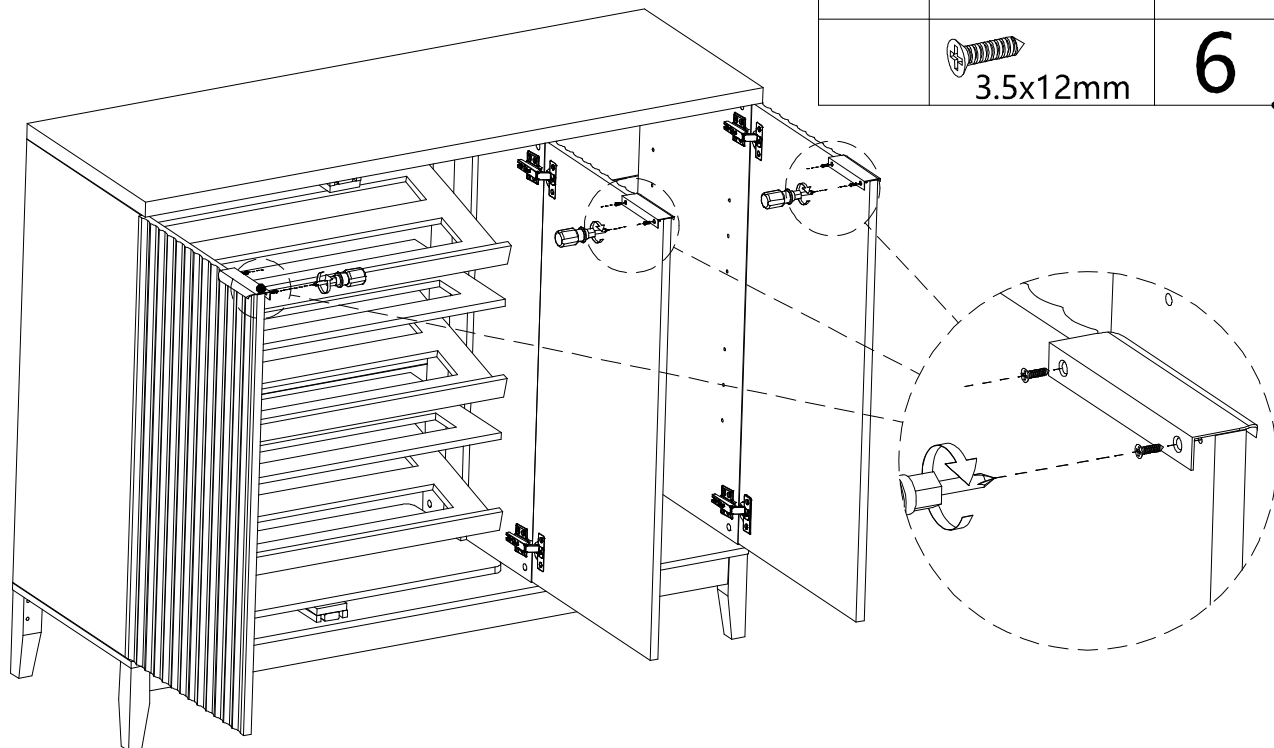

Step49

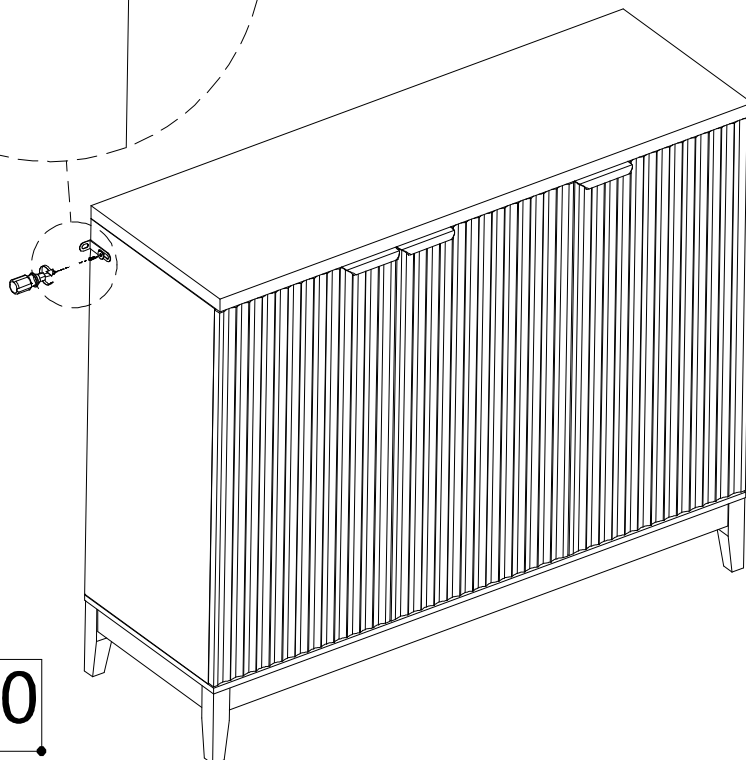
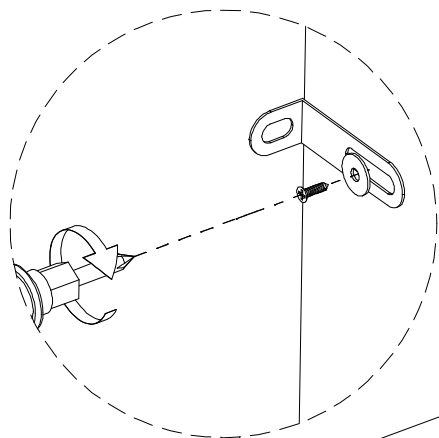

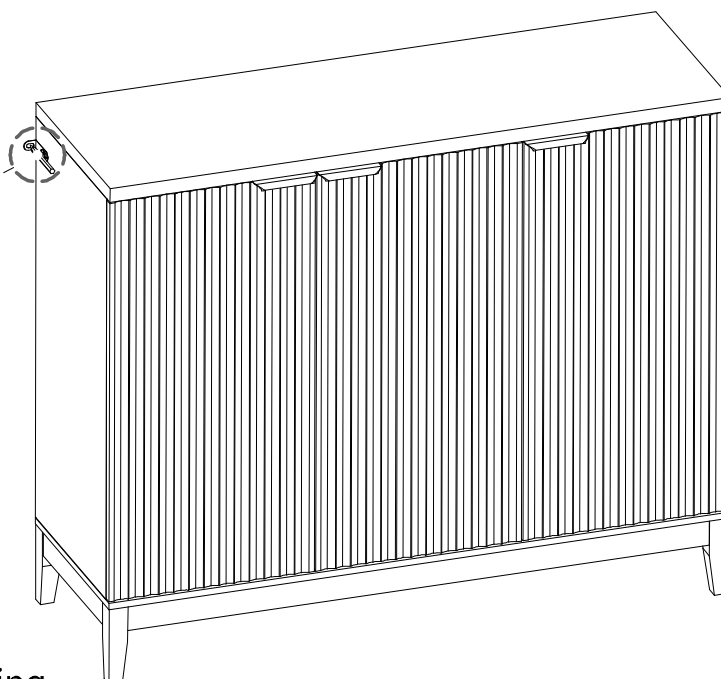
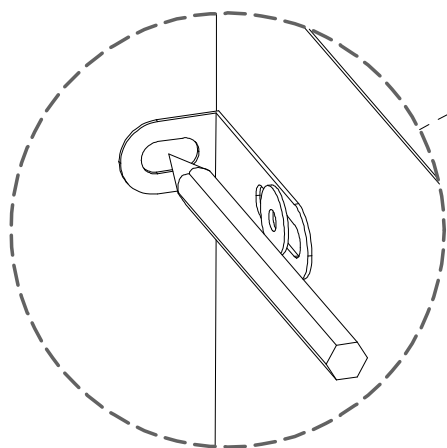

| Code | Diagram | count |
|------|---------|-------|
| N | | 1 |
| N | | 1 |
| N | | 1 |

Step50

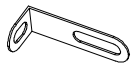

Mark the angle bracket's
center with a marker for drilling

Step51

| Code | Diagram | count |
|------|--|-------|
| N |  | 1 |
| N |  | 1 |
| N |  3.5x10mm | 1 |

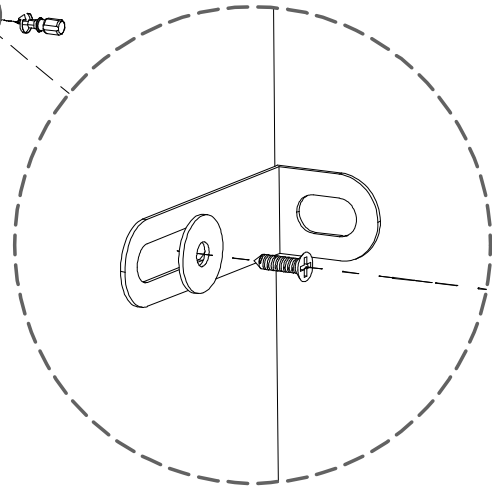
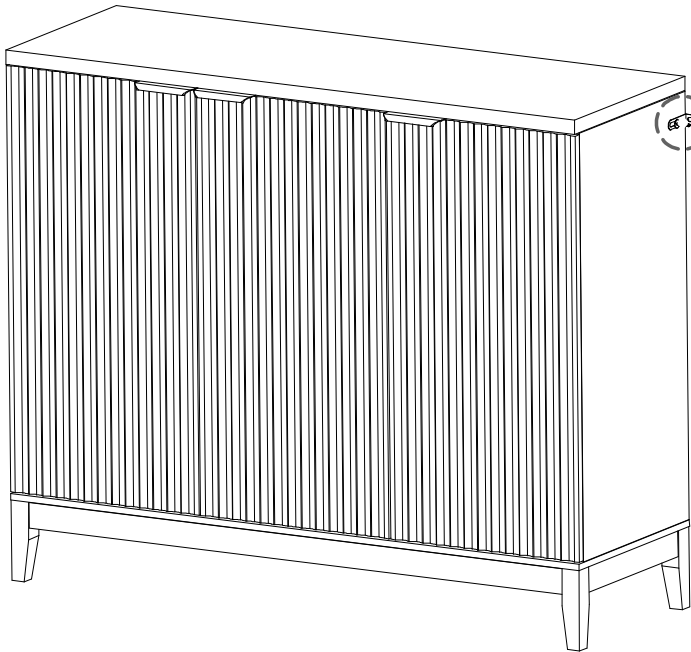

Step52

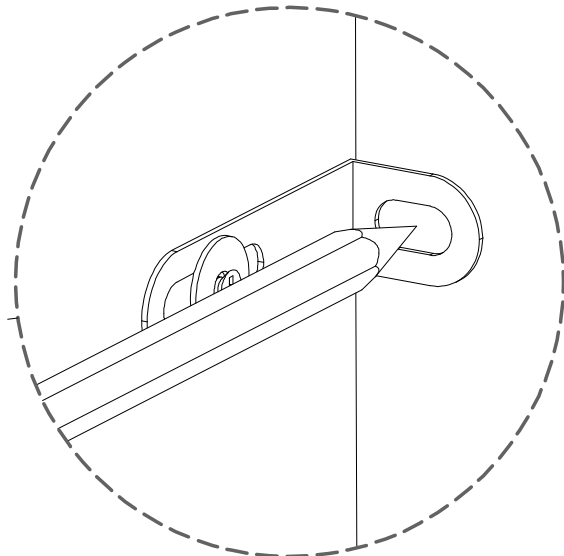
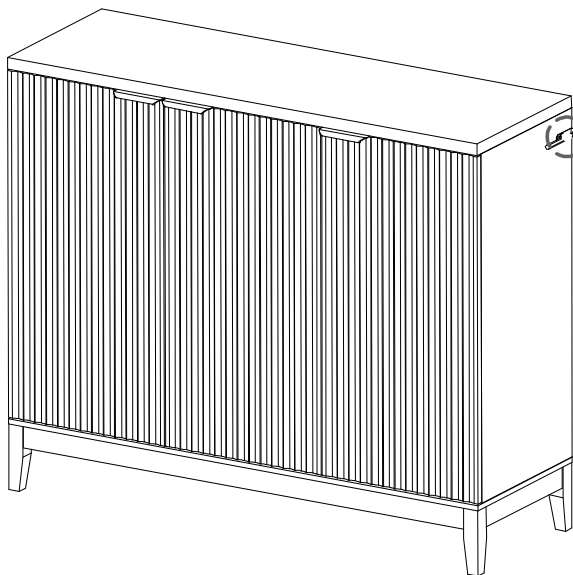

Mark the angle bracket's center with a marker for drilling

Step53

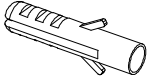
| Code | Diagram | count |
|------|---|-------|
| N |  | 2 |

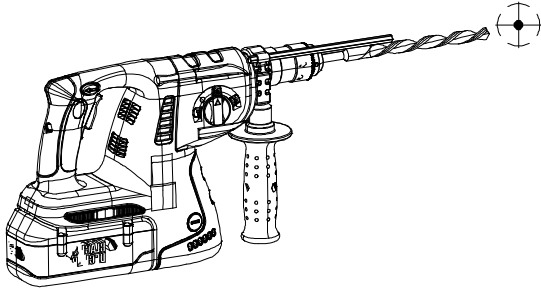

First drilling holes in the wall with a hammer drill
then Hammer in the expansion tube

Step54

| Code | Diagram | count |
|------|---|-------|
| N |  4x45mm | 1 |

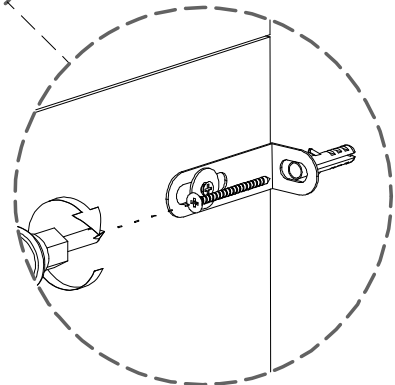
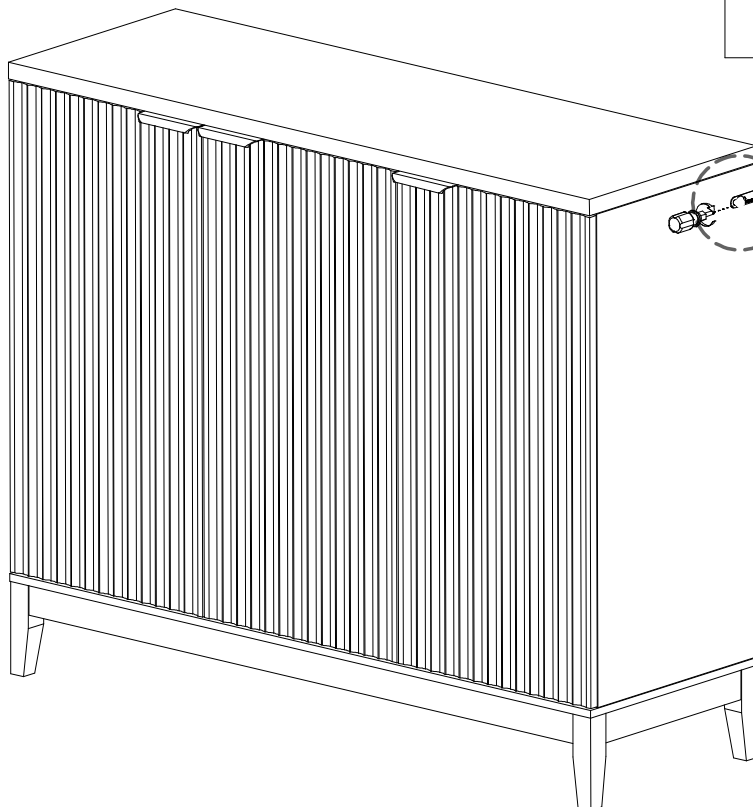

Step55

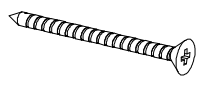
| Code | Diagram | count |
|------|---|-------|
| N |  4x45mm | 1 |

