

# Assembly Instructions

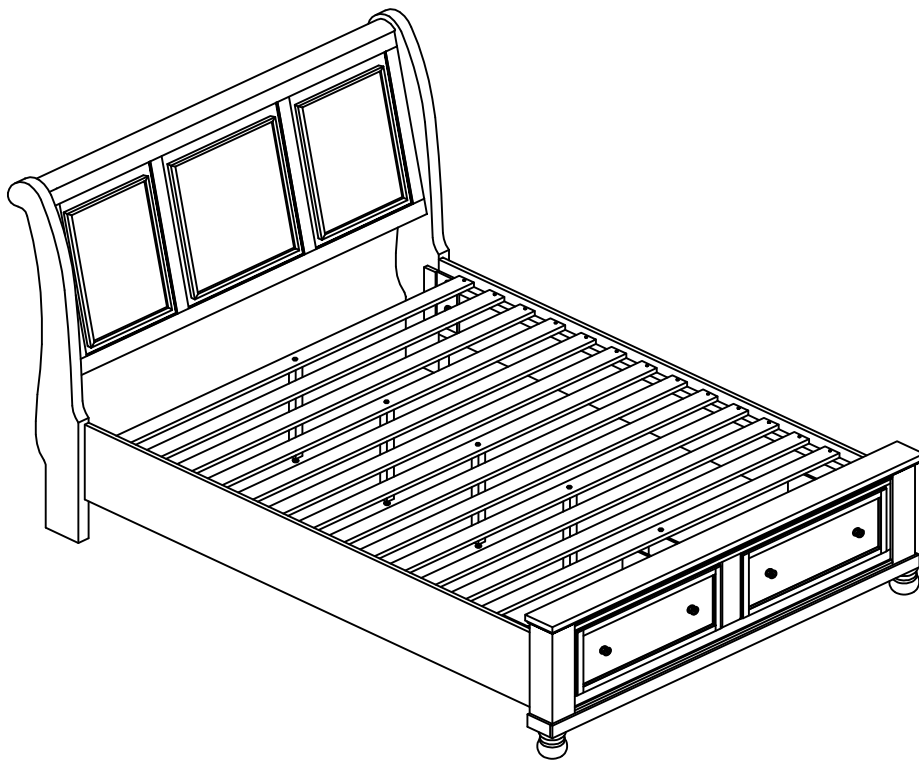

## ASSEMBLY RATING

The Assembly Rating is a 5-point system that shows the degree of effort needed in assembling a specific product (with 1 being easy and 5 being difficult). For some products, two persons are recommended.

EASY  DIFFICULT

## Tools Required For Assembly:

Allen Wrench



(Included)

Wrench

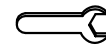

(Included)

Phillips Screwdriver

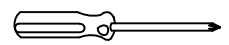

(Not Included)

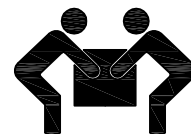

2 PERSONS RECOMMENDED

# ASSEMBLY & CARE ADVICE

FOR YOUR FURNITURE TO LAST, CORRECT ASSEMBLY AND PROPER MAINTENANCE ARE NECESSARY. PLEASE FOLLOW THE INFORMATION PROVIDED BELOW TO FULLY ENJOY YOUR FURNITURE.

## BASIC ASSEMBLY TECHNIQUES

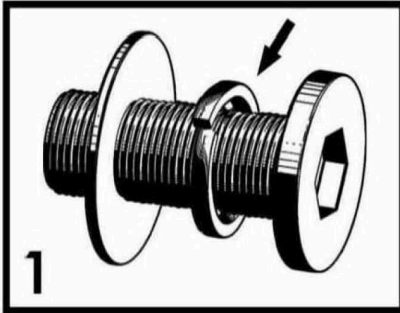

When lock or spring washer is used in an assembly, please make sure the lock or spring washer is placed between the larger flat washer and the head of the screw or bolt.

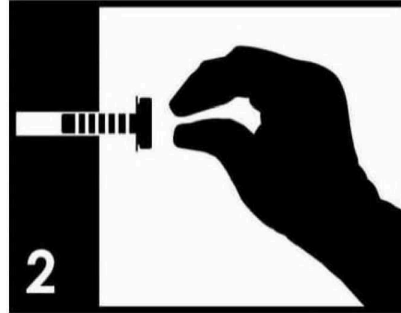

Position each part correctly and insert screws or bolts into their respective holes by hand tighten or using the proper hand tool. Only tighten when step is completed or when instructed to do so.

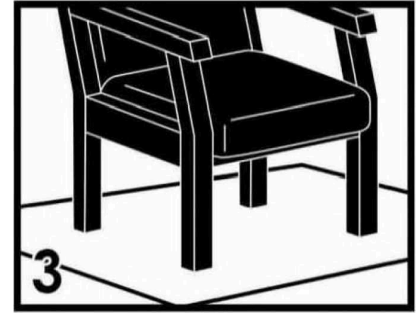

Use cardboard or carpet area when assembling furniture to prevent scratches. Make sure the furniture rests on a flat and level surface with each leg evenly touching the floor.

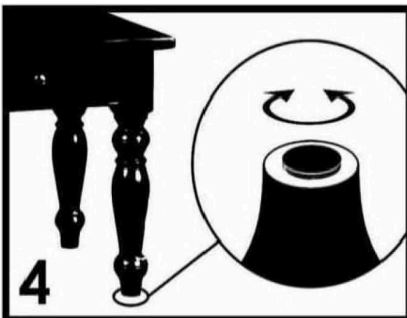

Some furniture comes with height adjustment knobs underneath each leg. To lower or to raise each leg, you need to turn clockwise or counterclockwise, respectively.

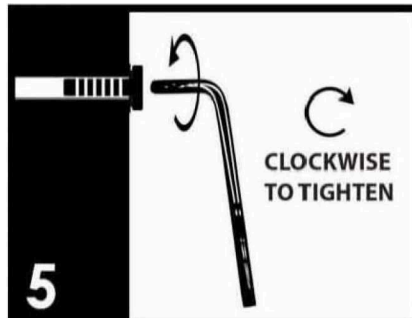

Make sure all parts are properly aligned, then use the appropriate hand tool to completely tighten the bolts or screws. Do not use power tools and do not overtighten.

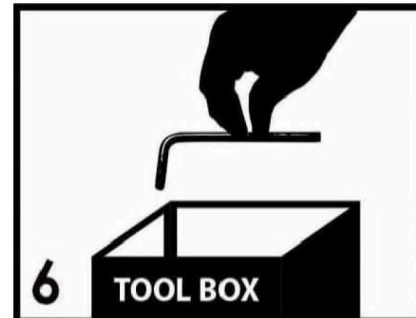

Save the instructions and store the Allen wrench or any supplied tool for later maintenance. After two weeks, check and tighten any loose hardware and repeat again every six months thereafter.

IT IS THE USER'S RESPONSIBILITY TO MAINTAIN THE FURNITURE. THE HARDWARE MAY LOOSEN OVER TIME AND MAY CAUSE THE FURNITURE TO BE WOBBLY AND UNABLE TO SUPPORT ITS INTENDED WEIGHT CAPACITY. THIS MAY LEAD TO COLLAPSE AND MAY CAUSE SERIOUS INJURY.

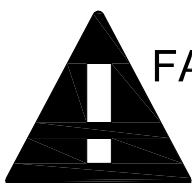

FAILURE TO FOLLOW THE GUIDELINES ABOVE MAY RESULT IN INJURY AND/OR PROPERTY DAMAGE.

ALL RIGHTS RESERVED.

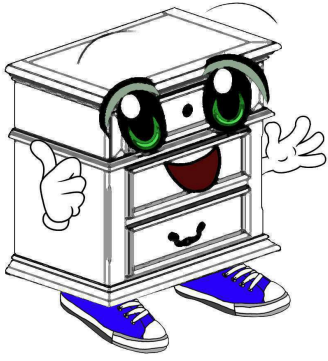

Before you begin, please read Page 2 of "Assembly and Care Advice".

And remember, do not tighten until each step is completed or instructed.

### Parts List

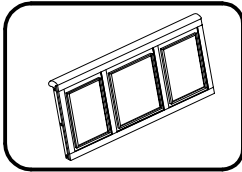

#1 x 1pc  
Headboard

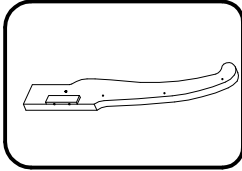

#2 x 2pcs  
Headboard leg (L&R)

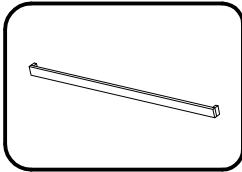

#3 x 1pc  
Headboard cross bar

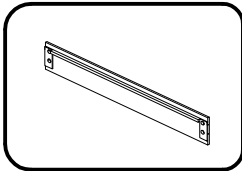

#4 x 2pcs  
Side rails

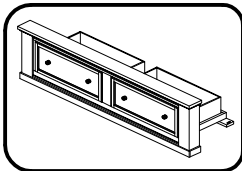

#5 x 1pc  
Storage footboard

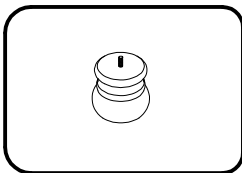

#6 x 2pcs  
Footboard bunfoot

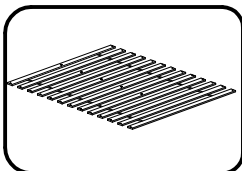

#7 x 1set  
Slat (13pcs)

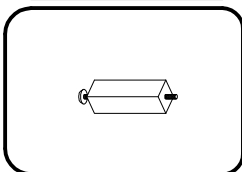

#8 x 2pcs  
Drawer support leg  
150 x 30 x 30mm

### Hardware List

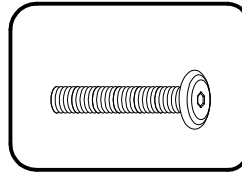

#A x 8pcs  
Bolt 5/16"-18 x 1-3/8"

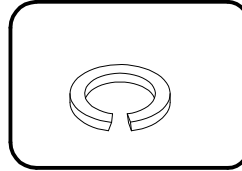

#B x 16pcs  
Lock Washer Ø5/16"

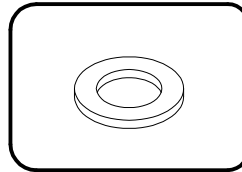

#C x 16pcs  
Flat Washer Ø5/16"

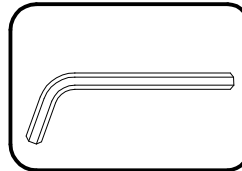

#D x 1pc  
Allen key

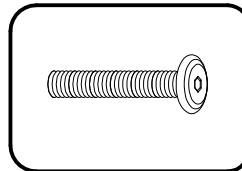

#E x 2pcs  
Bolt 1/4" x 1-5/8"

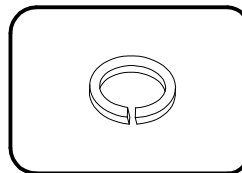

#F x 2pcs  
Lock washer Ø1/4"

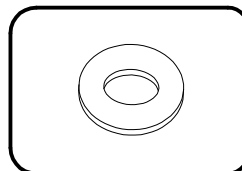

#G x 2pcs  
Flat washer Ø1/4"

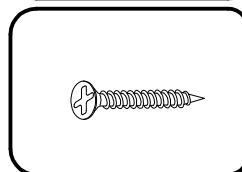

#H x 26pcs  
Screw 5/32" x 1-3/16"

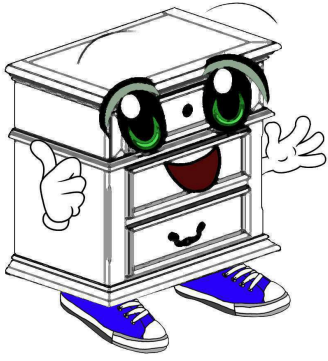

Before you begin, please read Page 2 of "Assembly and Care Advice".

And remember, do not tighten until each step is completed or instructed.

### Parts List

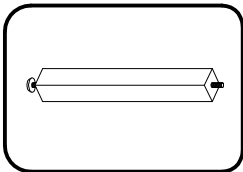

#9 x 4pcs  
Slat support leg  
385 x 30 x 30mm

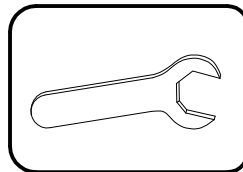

#L x 1pc  
Wrench

### Hardware List

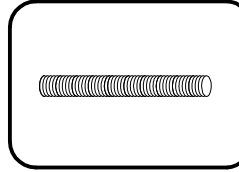

#I x 8pcs  
Thread rod  $\text{Ø}5/16"$  x 3-1/8"

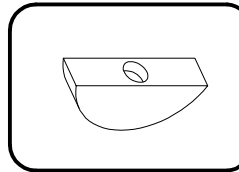

#J x 8pcs  
Half moon washer

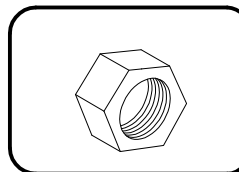

#K x 8pcs  
Hex nut  $\text{Ø}5/16"$

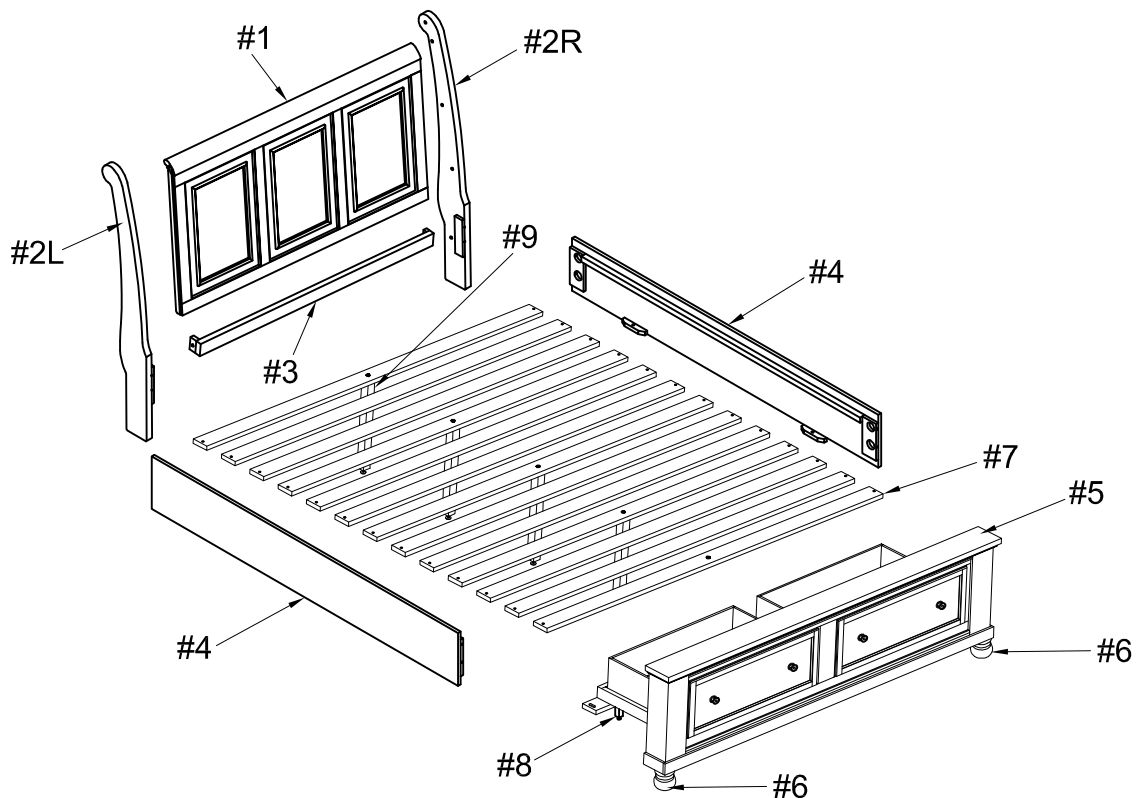



#1

Prepare 8 bolts assembly by inserting lock washer (#B), then flat washer (#C) onto bolts (#A). Align headboard (#1) and headboard cross bar (#3) to the holes of the headboard legs (#2R/L). Secure by using bolts (#A).

#A x 8pcs  
#B x 8pcs  
#C x 8pcs

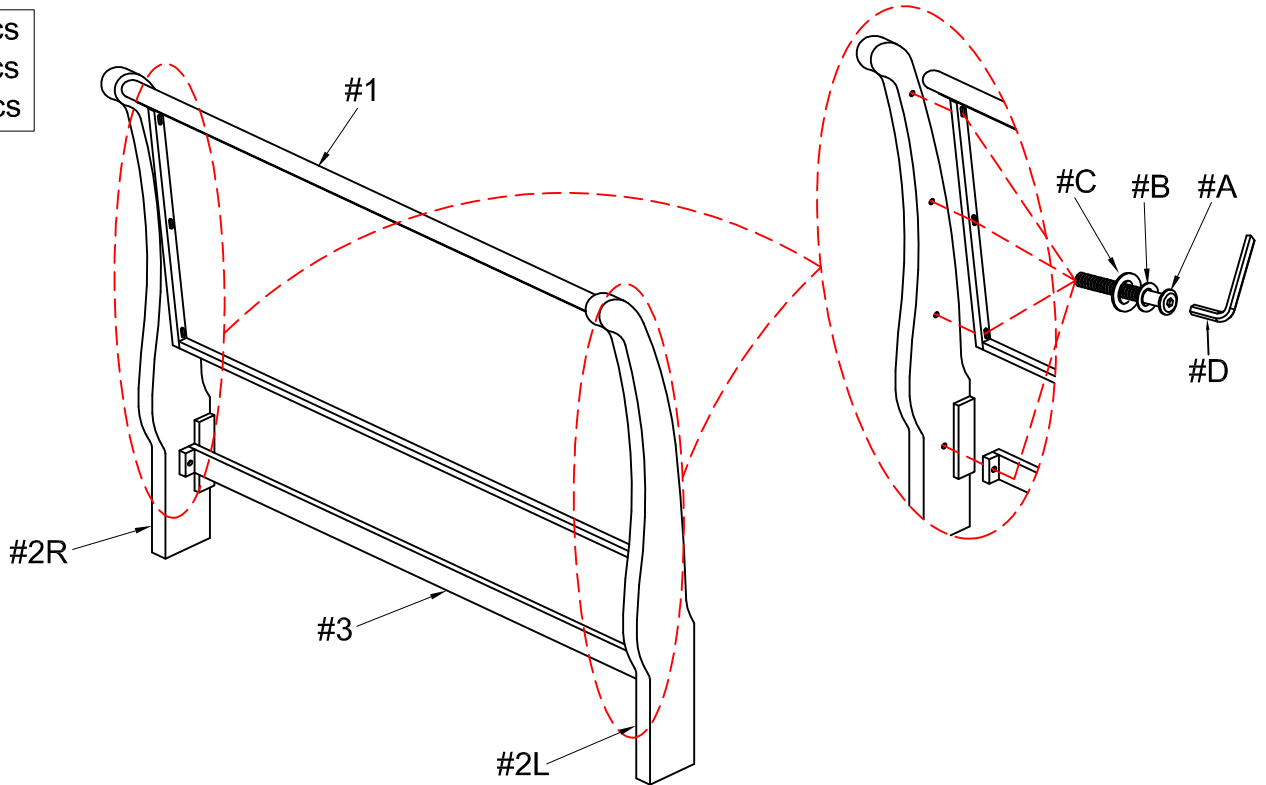

#2

Attach footboard bun foot (#6) to the bottom holes of the footboard (#5).

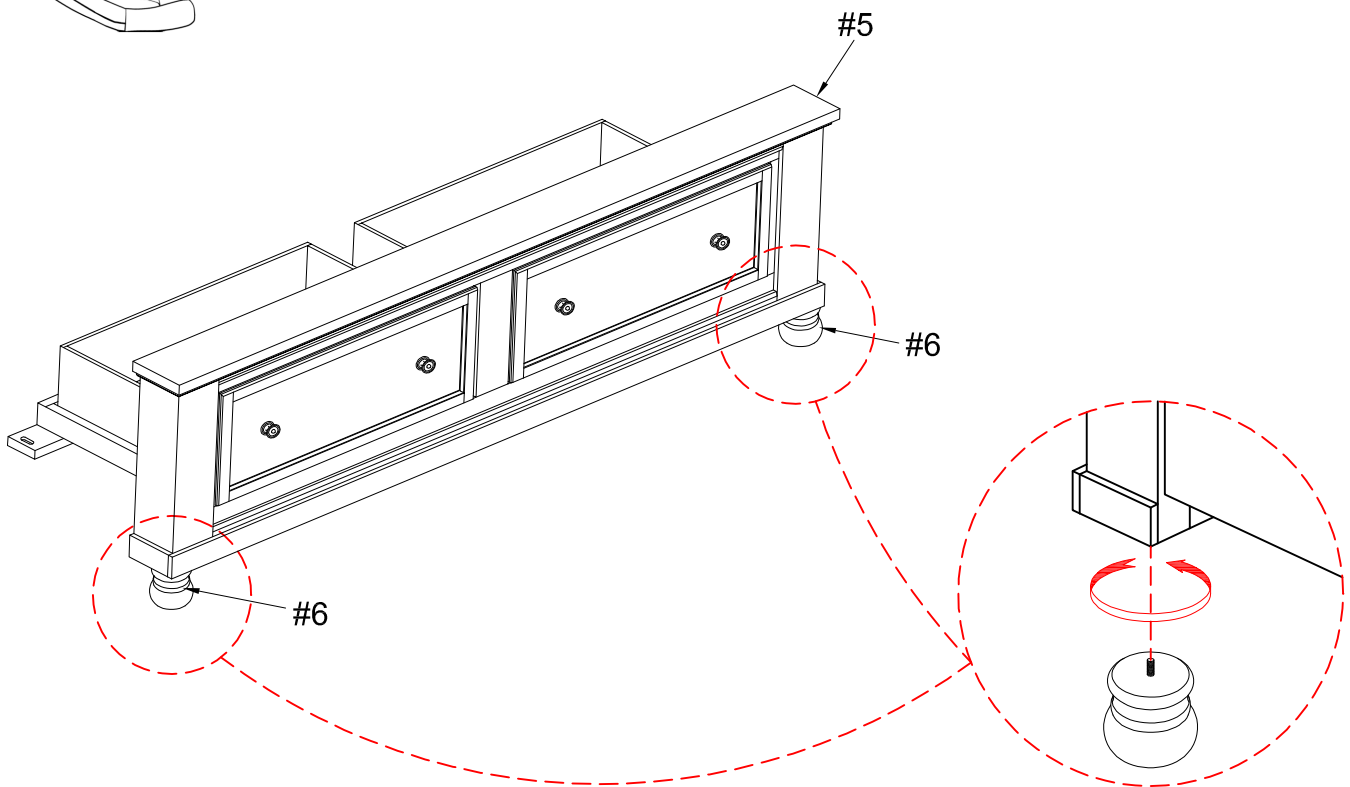



Attach support legs (#8) to the bottom holes of the footboard (#5). Adjust the leveler of the support legs (#8) according to ground level.

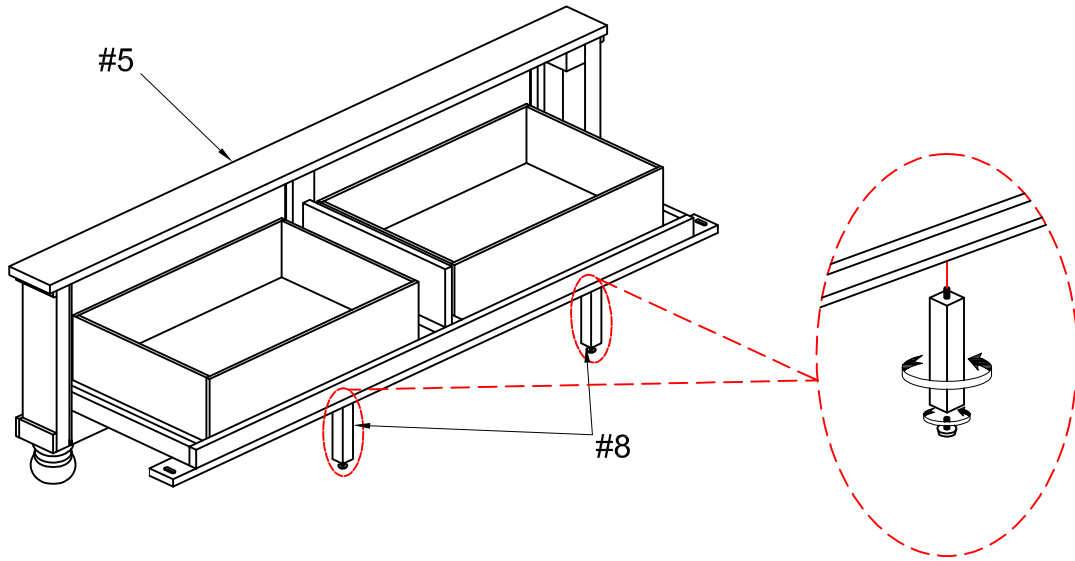

Attach treaded bolts (#I) to the foot board (#5) and headboard (#1). Align side rails (#4) to the threaded bolts of the foot board (#5) and headboard (#1). Secure by inserting half moon (#J), flat washer (#C), lock washer (#B) and hex nut (#K).

- #B x 8pcs
- #C x 8pcs
- #I x 8pcs
- #J x 8pcs
- #K x 8pcs

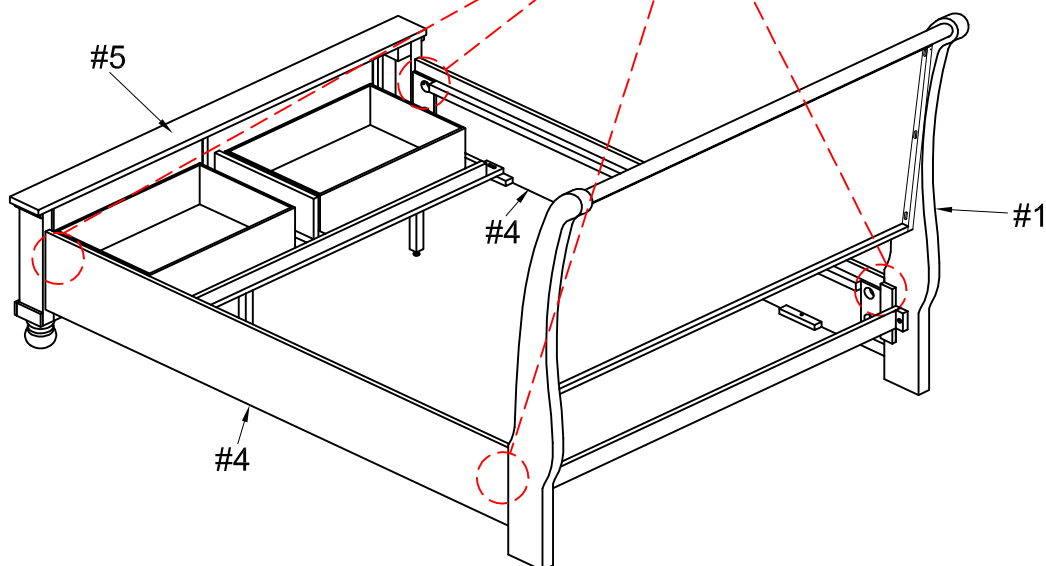
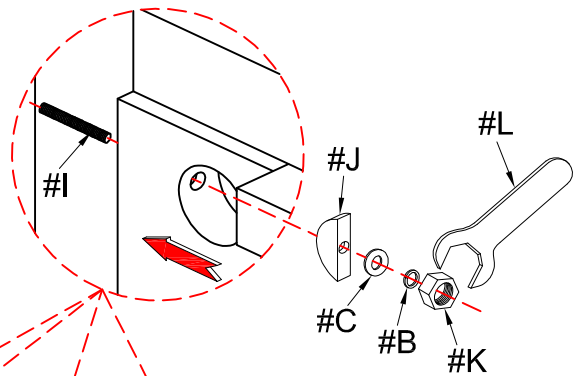



Prepare 2 bolts assembly by inserting lock washer (#F), then flat washer (#G) onto bolts (#E). Align and secure foot board (#5) to the side rails (#4) by using bolts (#E).

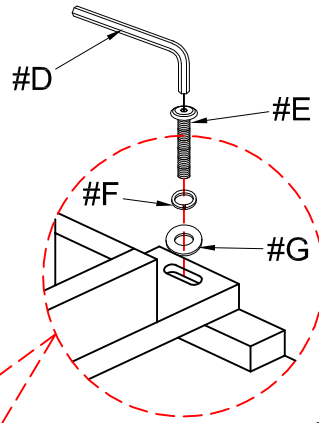

- #E x 2pcs
- #F x 2pcs
- #G x 2pcs

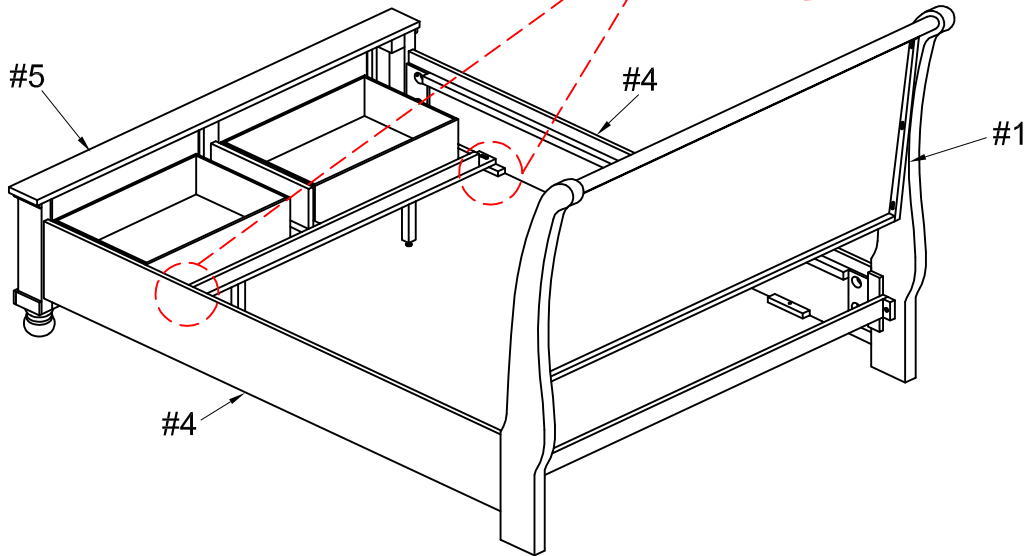

Attach support legs (#9) to the holes of the slats (#7). Adjust leveler of the support legs (#9) according to ground level.

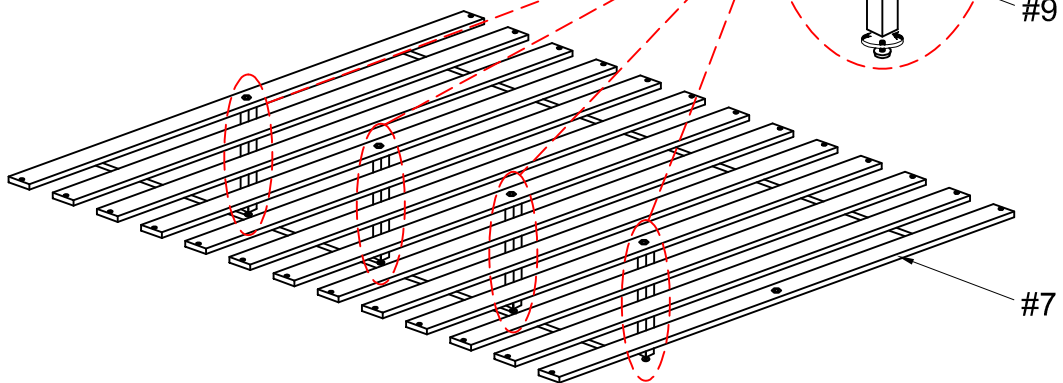
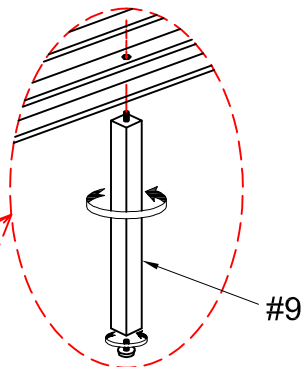



#7

Align slats to the side rails (#4), then secure by using screws (#H).

#H x 26pcs

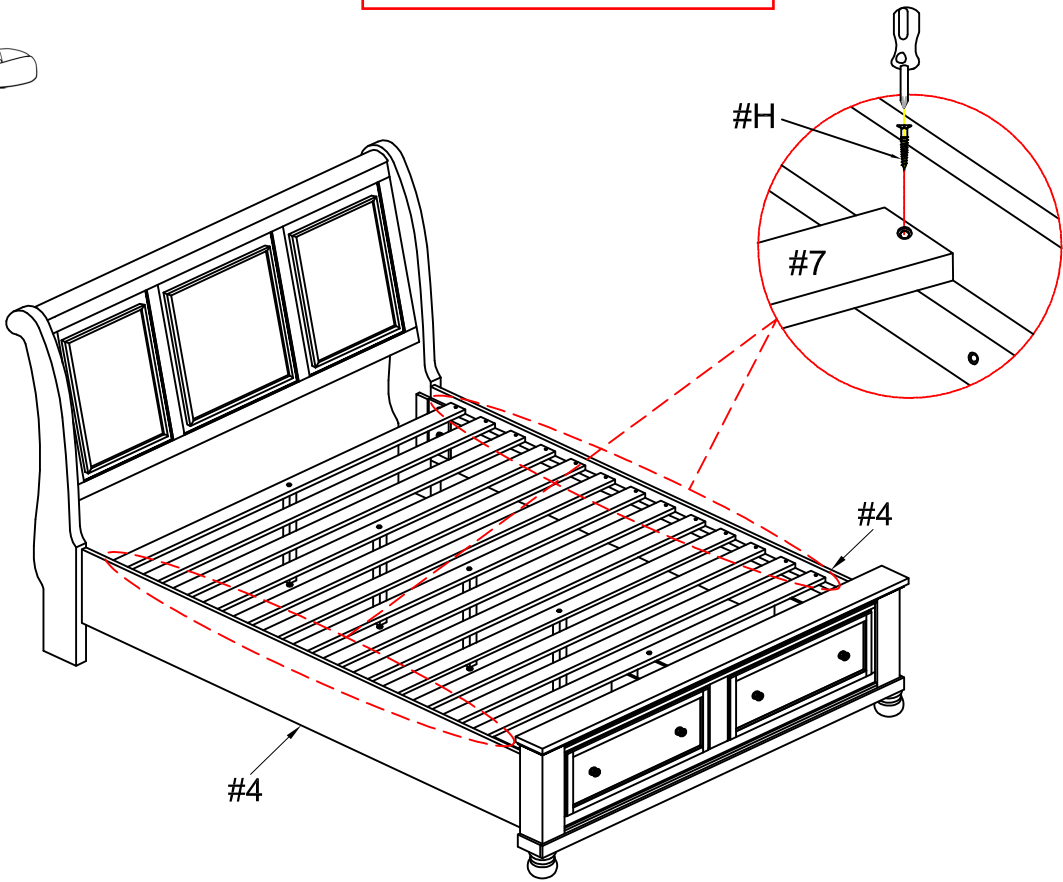

#H

#7

#4

#4



#8

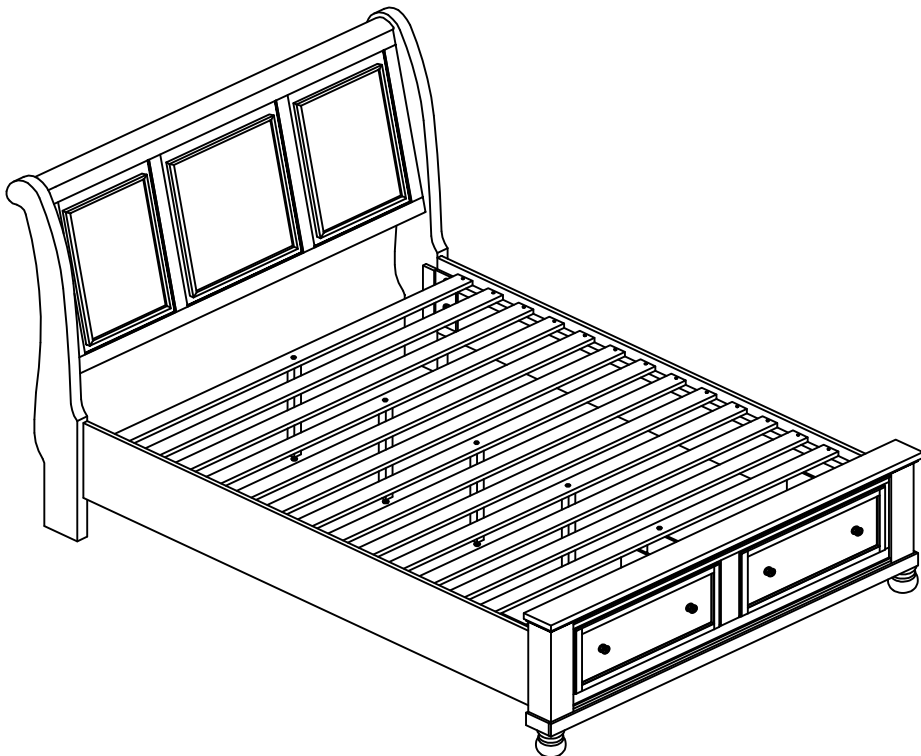

ASSEMBLY IS COMPLETED