

ASSEMBLY INSTRUCTIONS



END TABLE

ASSEMBLY INSTRUCTIONS

ASSEMBLY TIPS:

1. Remove hardware from box and sort by size.
2. Please check to see that all hardware and parts are present prior to start of assembly.
3. Please follow attached instructions in the same sequence as numbered to assure fast & easy assembly.





WARNING!

1. Don't attempt to repair or modify parts that are broken or defective. Please contact the store immediately.
2. This product is for home use only and not intended for commercial establishments.





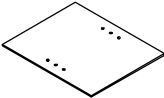
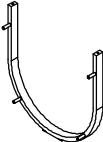



ASSEMBLY TIME 28 MINUTES

PARTS IDENTIFICATION

A	TOP GLASS		1PC
B	BOTTOM HALF MIRROR		1PC
C	SUPPORT FRAME		2PCS
D	CROSSBAR		4PCS

HARDWARE IDENTIFICATION

1	BOLT (5/16" x 25mm)		6PCS	4	PLASTIC WASHER (5/16")		6PCS
2	SHORT BOLT (3/16" x 8mm SR)		8PCS	5	SUCTION CUP (ø8mm)		4PCS
3	WASHER (5/16")		6PCS	6	FOOT PAD (ø40 x 15mm)		4PCS

ASSEMBLY INSTRUCTIONS

7 SPRING WASHER
(5/16") 6PCS



9 SMALL ALLEN WRENCH
(4mm) 1PC



8 LARGE ALLEN WRENCH
(5mm) 1PC

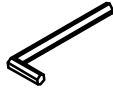

STEP 1

Do not tighten until each step is completed or instructed.

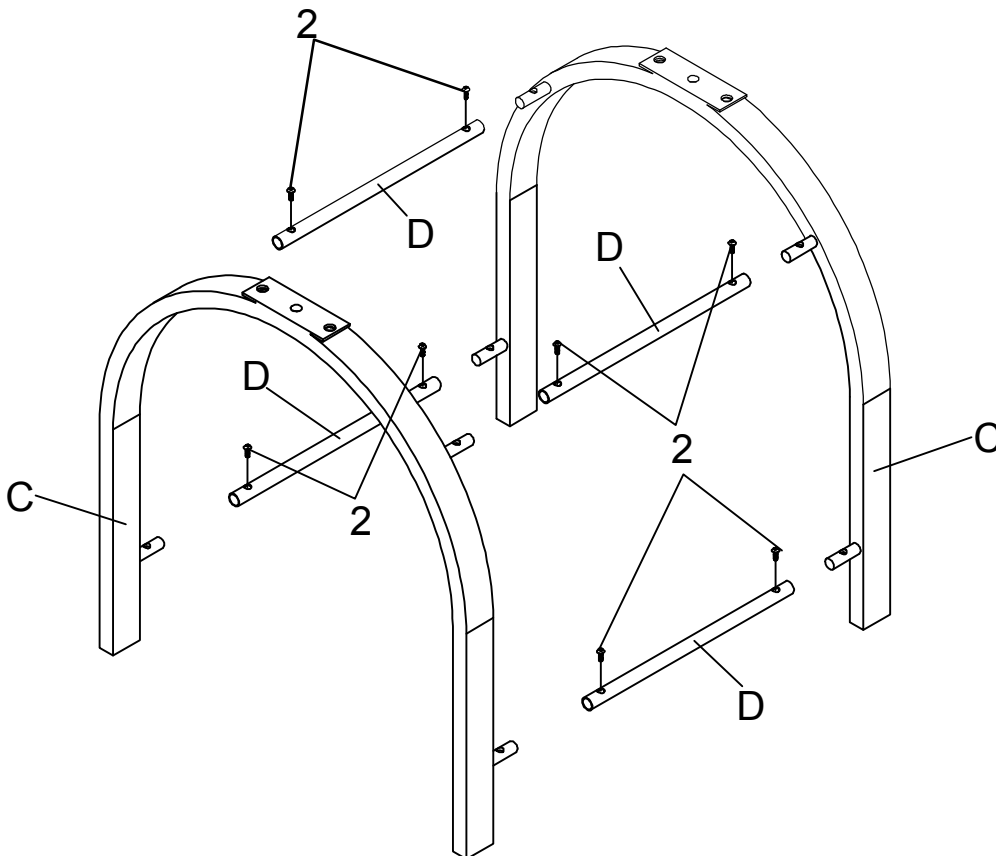

ASSEMBLY INSTRUCTIONS

STEP 2

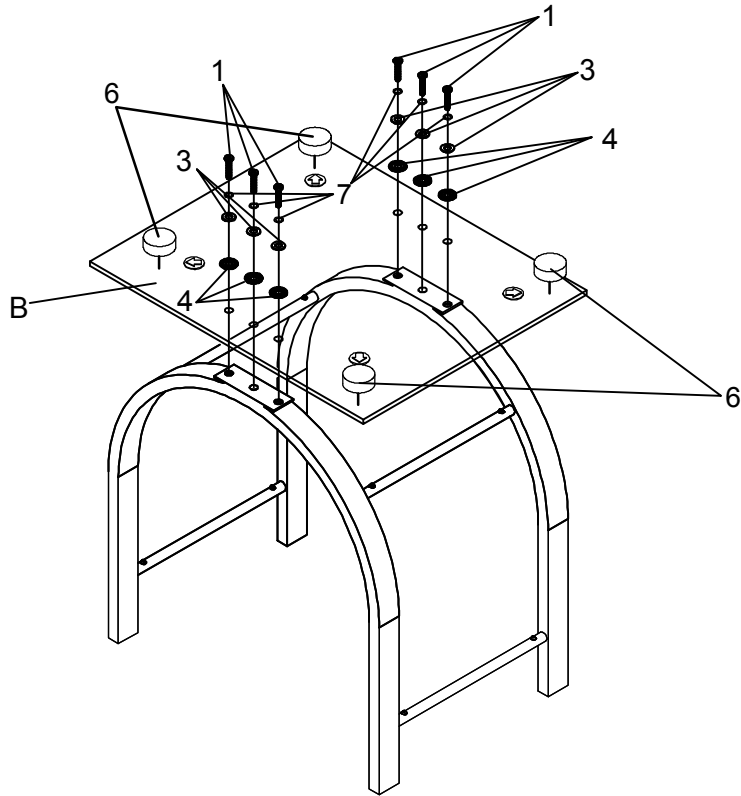

STEP 3

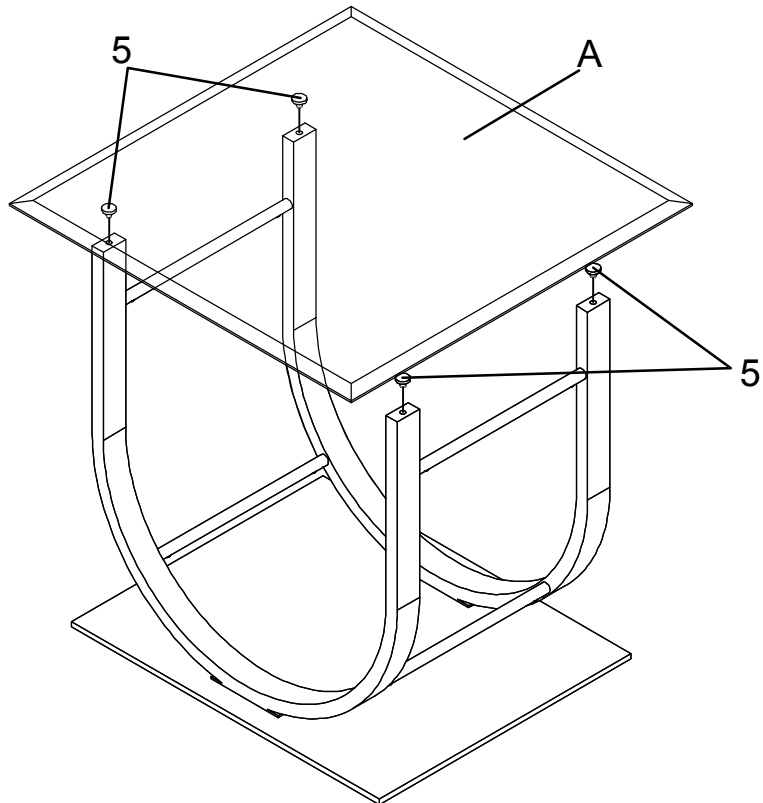

ASSEMBLY INSTRUCTIONS

Product Size : 610 X 610 X 596 H (MM)

Product Size : 24" X 24" X 23 ½"

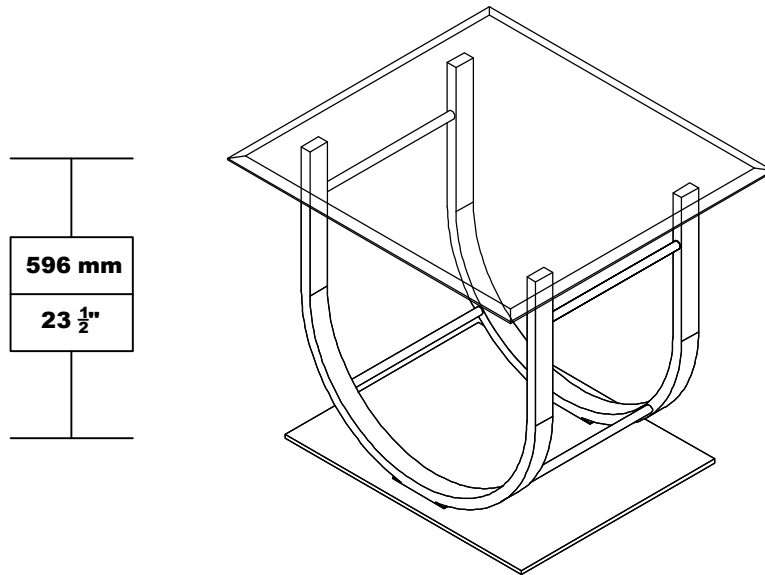

610 mm	610 mm
24"	24"

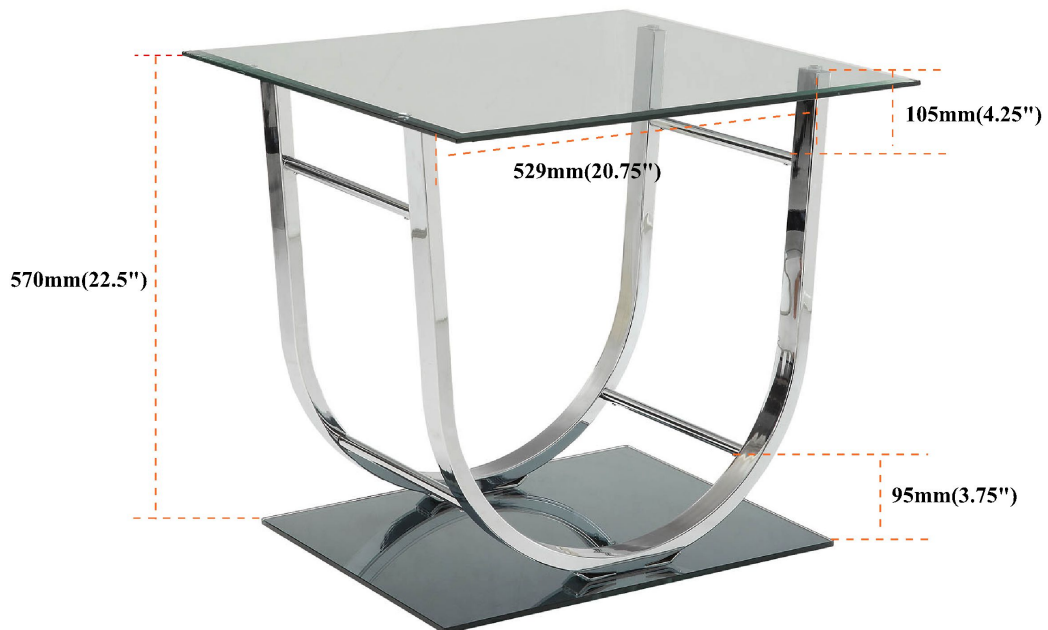

Note : Dimension tolerance $\pm 5\%$