

This article contains biocidal products to give protection against wood destroying insects & wood rotting fungi. Contents may vary. May contain : Basic copper carbonate (Copper (II) carbonate – Copper (II) hydroxide (1:1), Cupric oxide, Copper hydroxide carbonate, oxyethyl, ammoniumpropionate, Copper HDO, Propiconazole, Tebuconazole, Boric acid, Benzalkonium chloride. Wear gloves when handling freshly treated wood. Avoid breathing dust when cutting treated or untreated wood. Dispose of off-cuts responsibly – do not burn.

Pre-drill
for each screw
used.



Large Pent Out Door Store

This fixing pack covers multiple products. Please make sure you quote from the relevant parts list in the event you need to order missing or damaged parts.

Tools Required Not Supplied

Drill/Pozi Drive
Screwdriver



Hammer



Sharp Knife



Tape Measure



Spirit Level

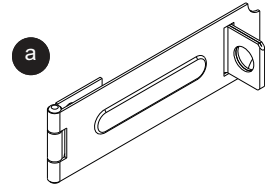

Hasp And Staple Qty 1



25mm Screw Qty 45

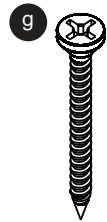

30mm Screw Qty 10

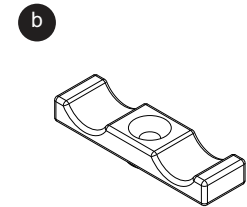

Turn Button Qty 2

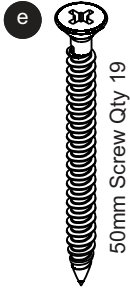

50mm Screw Qty 19

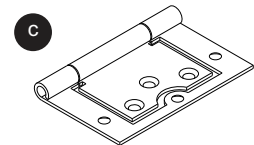

Flush Hinge Qty 4

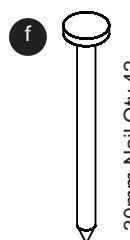

30mm Nail Qty 42



Felt Tacks Qty 40

OPPLOS (Pressure Treated Overlap) PARTS LIST

Item	Part Code	Part Description	Quantity
1	OPOSBP	OLAP PTR OUTDOOR STORAGE BACK PANEL	1
2	POSFP	PTR OUTDOOR STORE FRONT PANEL	1
3	OPOSSP	OLAP PTR OUTDOOR STORAGE SIDE PANEL	2
4	POSDR	PTR OUTDOOR STORE DOOR	2
5	POSRF	PENT OUTDOOR STORE ROOF	1
6	45281183PT	BATTEN 45x28x1183mm PTREAT	1
7	73120694PAI4PT	BOARD 73x12x694mm PAR ANGLED PTREAT	2
8	45451828PT	BATTEN 45x45x1828mm PTREAT	1
9	44121372PPT	STRIP 44x12x1372mm PAR PTREAT	2
10	121120850PPT	BOARD 121x12x850mm PAR PTREAT	2
11	121121960PPT	BOARD 121x12x1960mm PAR PTREAT	1
12	18287508	OSB 1828x750x8mm	1
13	28281828PT	BATTEN 28x28x1828mm PTREAT	3
14	28280070PT	BATTEN 28x28x70mm PTREAT	2
15	44161372PT	STRIP 44x16x1372mm PTREAT	2
16	85063	BLACK FELT 2.5 METRES	1

SPPLOS (Shiplap) PARTS LIST

Item	Part Description	Part Code	Quantity
1	SPOSBP	SLAP PTR OUTDOOR STORAGE BACK PANEL	1
2	POSFP	OLAP PTR OUTDOOR STORE FRONT PANEL	1
3	SPOSSP	SLAP PTR OUTDOOR STORAGE SIDE PANEL	2
4	POSDR	PTR OUTDOOR STORE DOOR	2
5	POSRF	PENT OUTDOOR STORE ROOF	1
6	45281183PT	BATTEN 45x28x1183mm PTREAT	1
7	73120694PAI4PT	BOARD 73x12x694mm PAR ANGLED PTREAT	2
8	45451828PT	BATTEN 45x45x1828mm PTREAT	1
9	44121372PPT	STRIP 44x12x1372mm PAR PTREAT	4
10	121120850PPT	BOARD 121x12x850mm PAR PTREAT	2
11	121121960PPT	BOARD 121x12x1960mm PAR PTREAT	1
12	18287508	OSB 1828x750x8mm	1
13	28281828PT	BATTEN 28x28x1828mm PTREAT	3
14	28280070PT	BATTEN 28x28x70mm PTREAT	2
16	85602	GREEN FELT 2.5 METRES	1

Attention:

- For Domestic Use Only.
- Must be built on a **solid and level** base.
- Regularly check that all fixing are tight and secure.
- Regularly check the felt for damage.

Important:

Assembly of this product requires a minimum of two adults.

Please check all parts prior to assembly.

This product is pressure treated to ensure longevity of all timber components and to protect against rot. This may leave a colour difference on some parts that will even out as the moisture content stabilises. This will not need additional treatment.

- Please keep all plastic bags and small parts away from children.
- The roof of this product is not a load bearing structure.
- Timber is a natural material and will shrink and swell as a result of varying moisture content.

Assembly of damaged parts may be deemed to be acceptance and this may affect the remedies you are entitled to. If the product is not constructed in accordance with the instructions, or is altered in anyway (e.g. painted), the manufacturer cannot be held liable for any resulting damage.

A Floor and Barge Board assembly

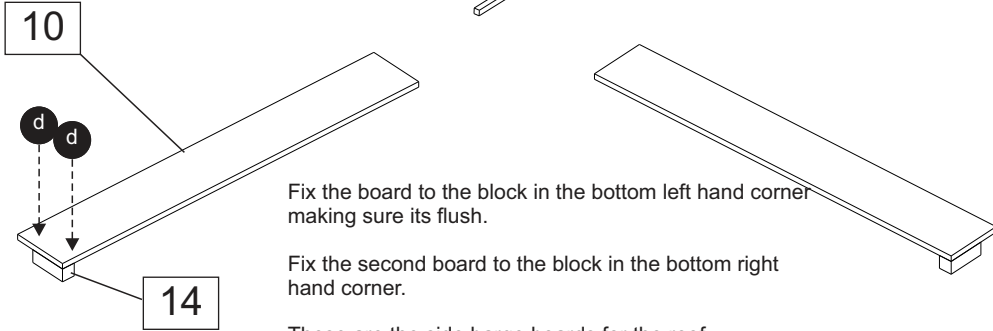
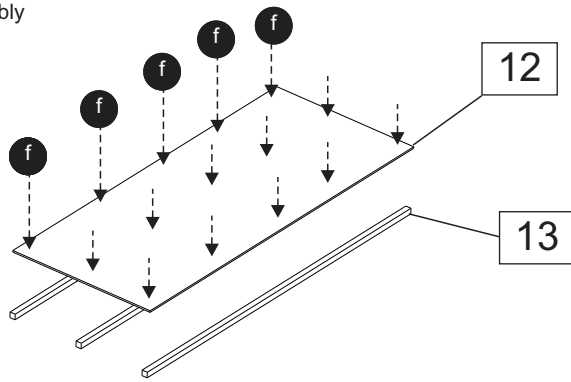
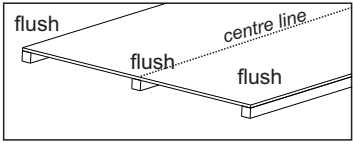

B

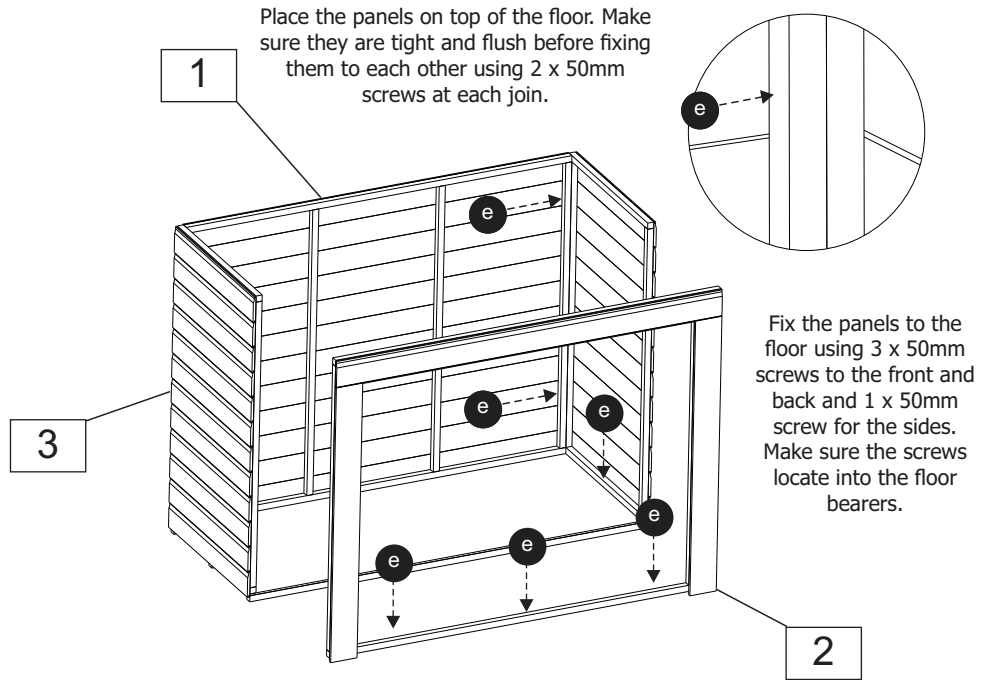

PRE-DRILL

PRE-DRILL

PRE-DRILL

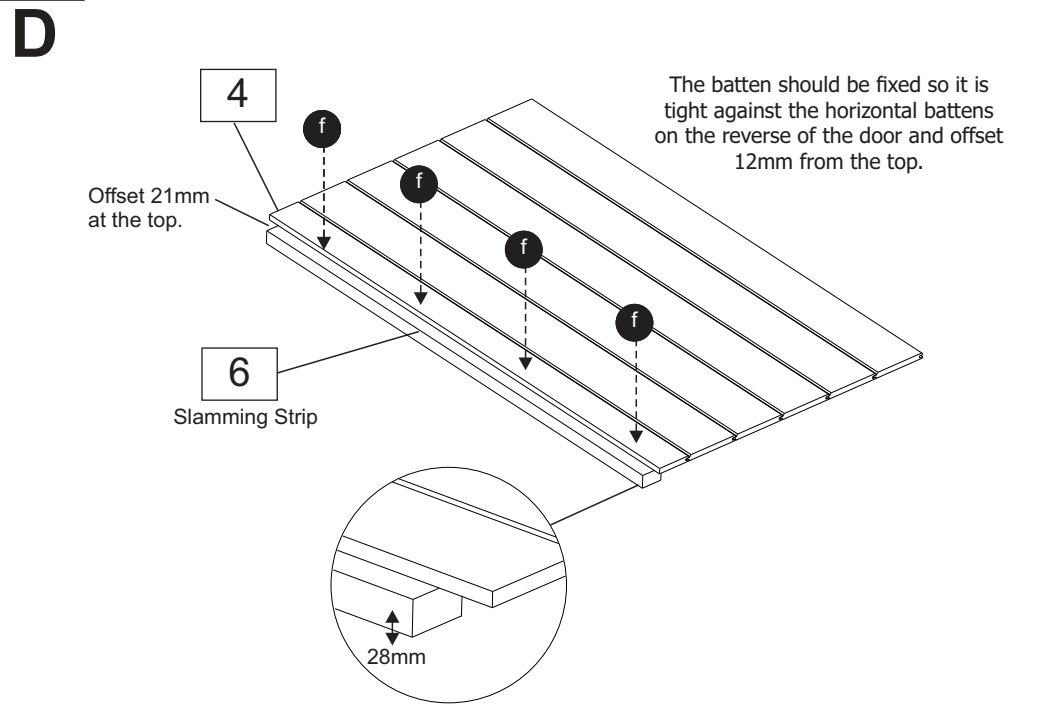
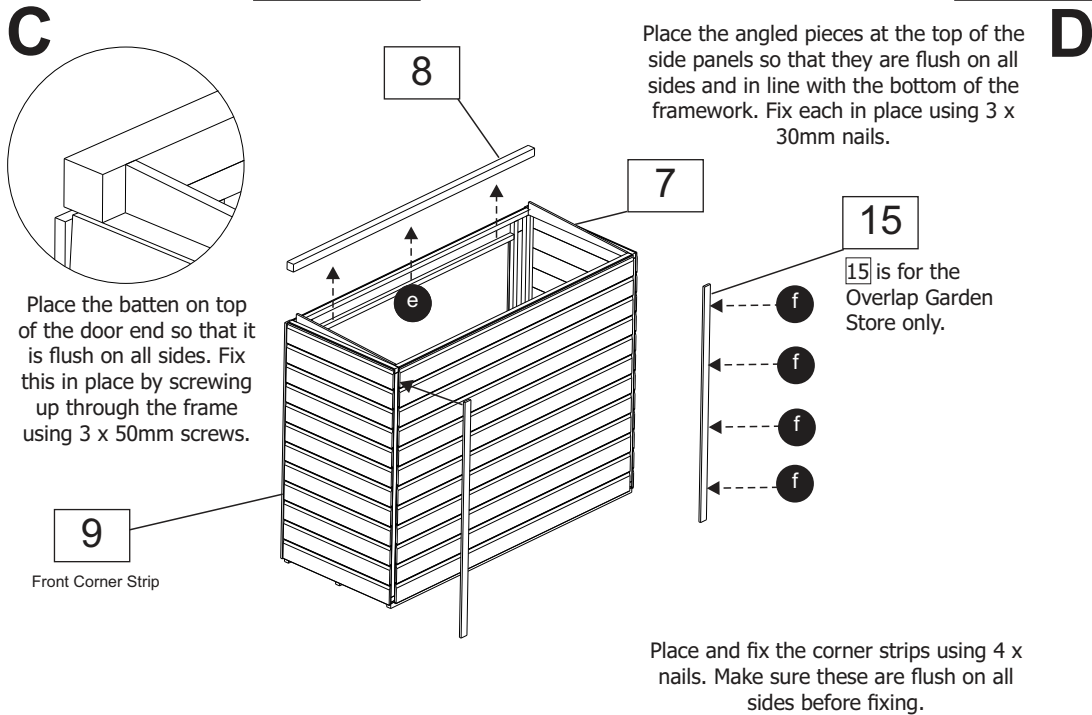

E

Place a turn button on the top and bottom of the batten.

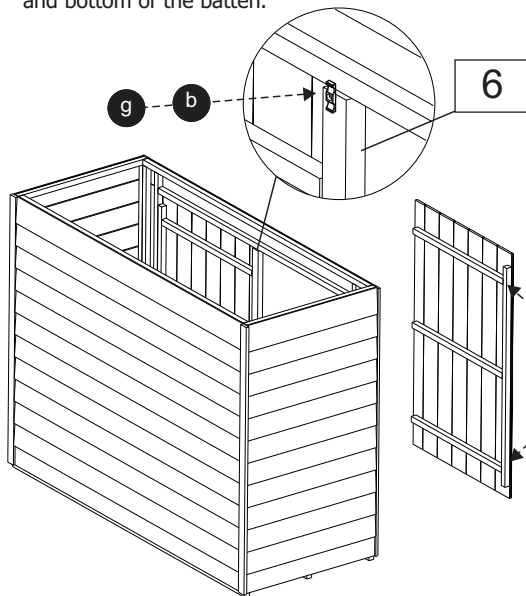

The top of the hinge should be in line with the horizontal batten

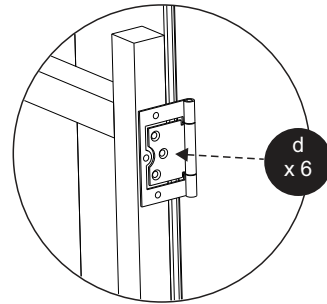

Fix the smaller piece of the hinge to the door.

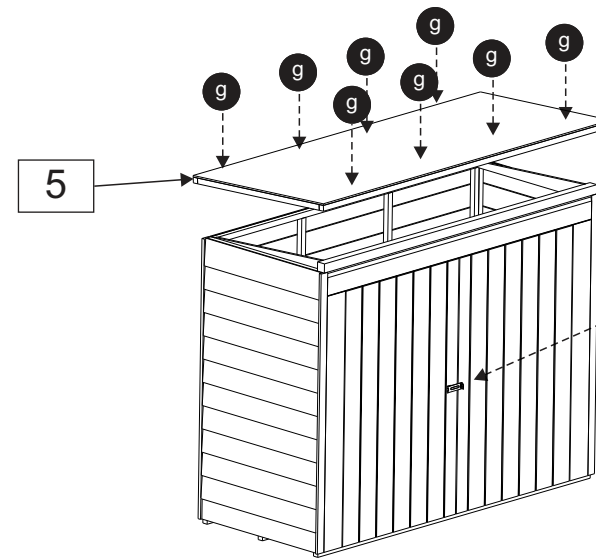
F

Fix the roof to the Tall Store screwing down through the OSB sheet into the framing using 30mm screws.

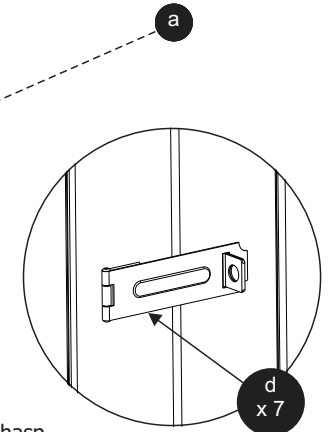

Position and line up the hasp and staple with framing on the inside of the door.

PRE-DRILL 

PRE-DRILL 

PRE-DRILL 

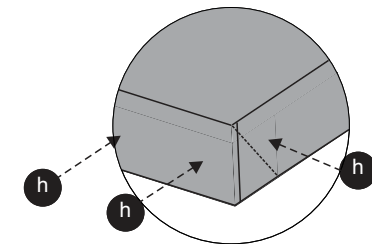
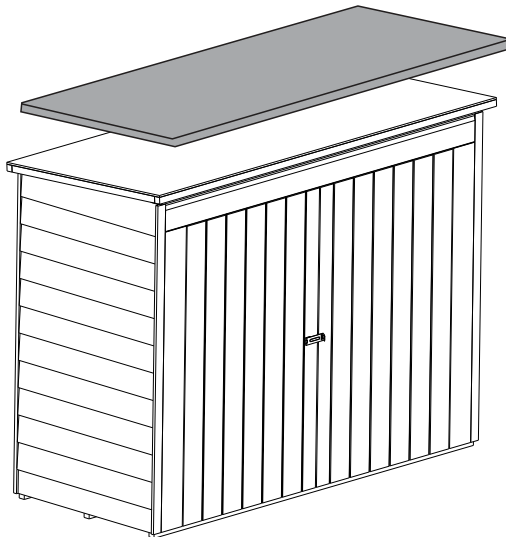
G

Place the felt over the roof so that there is approximately a 45mm overhang on all sides. Secure the felt to the roof, nailing into the battens from the sides using felt tacks placed in 150mm intervals.

Cut and fold the felt at the corners as shown.

Take care when trimming the roof felt.

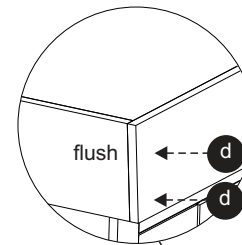
H

Position and fix the side (smaller) barge boards against the sides using 2 x 25mm screws.

Place the front barge board against the roof so that it lines up on all sides. Fix it to the roof battens using 2 x 25mm screws positioned as shown.

Further secure the barge board at the corner screwing into each of the blocks at the ends using 2 x 25mm screws for each.

