

ASSEMBLY INSTRUCTIONS & PARTS IDENTIFICATION

DESK CHAIR ANT CREAM

Thank you for purchasing this quality product. Be sure to check all packing material carefully for small parts that may have come loose inside the carton during shipment

Hardware kit			
No		Description	Q'ty
A		Hexa Nut 5/16"	4 pcs.
B		Lock Washer 5/16"	11 pcs.
C		Flat Washer 5/16"	11 pcs.
D		Long Bolt 1/4"x 3".	4 pcs.
E		Short Bolt 1/4"x 1"1/2.	3 pcs.
F		Allen Key	1 pc.
G		Key Wrench	1 pc.
H		Wood Screw 1/6"x 38	4 pcs.

Chair Parts Key			
No		Description	Q'ty
1		Chair Back	1 pc.
2		Complete Seat	1 pc.
3		Right Facing Front Leg	1 pc.
4		Left Facing Front Leg	1 pc.
5		Right Facing Stretcher	1 pc.
6		Left Facing Stretcher	1 pc.
7		Floor glide	4pcs.

FABRIC CARE INTRUCTIONS: Blot gently using a clean soft damp cloth an mild detergent **DO NOT SATURATE FABRIC CONTENT:** 100% POLYESTER-CLEANING CODE W

STEP 1

- Carefully lay chair back flat on a smooth flat surface to prevent scratches
- Attach Complete Seat to Chair back by inserting a Flat Washer (C) Lock Washer (B) with Short Bolt (E) into each of the hole on the back rail of the seat, and Long Bolt (D) a Flat Washer (C) and Lock Washer (B) into each of 2 holes in the Complete Seat corners. (See Detail A & B)
- Tighten screws with provided Allen Key (F) by turning clockwise until secure

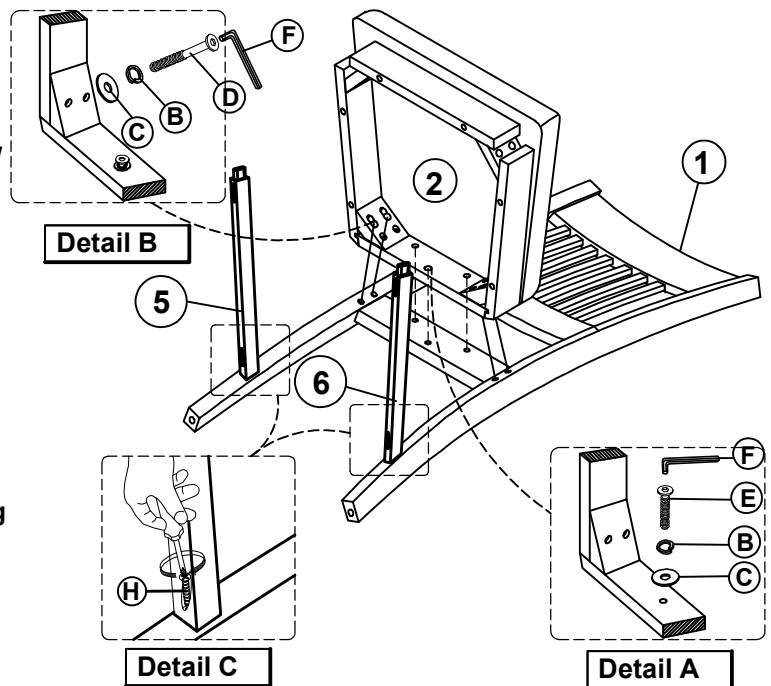

STEP 2

- Carefully turn Chair upside down. Insert the right stretcher into the back right leg, then position right front leg in to the front corner block and connect the stretcher to the front leg
- Insert the left stretcher into the back left leg, then position left front leg in to the front corner block and connect the stretcher to the front leg. (See Detail C)
- Place Flat Washer (C), Lock Washer (B) and Nut (A) on each bolt, and hand tighten at this point
- Fasten Stretchers with Wood Screws (H) by hand using a Philips screwdriver (not provider) (See Detail C). Fully tighten the nuts for the front leg.
- Check to be sure all screws and nuts are tight prior to using Chair.

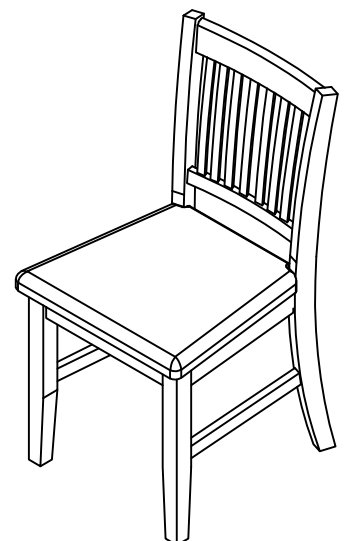
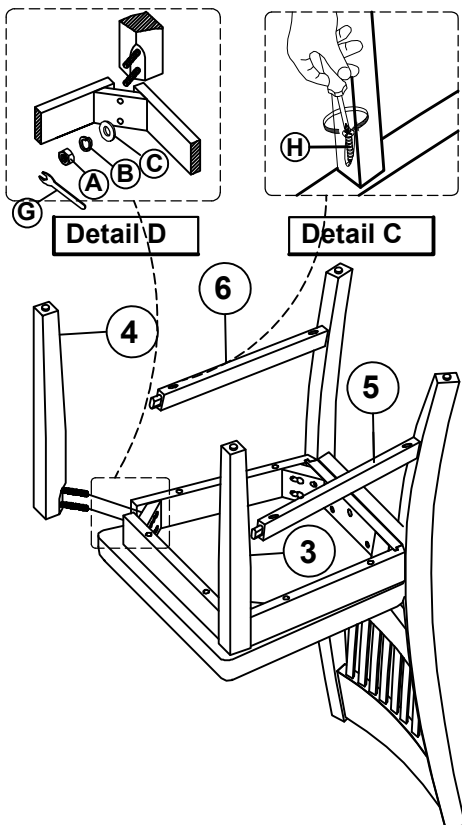

ASSEMBLY INSTRUCTION & PARTS IDENTIFICATION

DESK

Thank you for purchasing this quality product. Be sure to check all packing material carefully for small parts that may have come loose inside the carton during shipment.

Parts key			
No		Qty	Description
1		2 pcs	Drawer Complete
2		2 Sets	Knob w/ Screw
3		2 Sets	Drawer Stop
4		2 Sets	Drawer Glide
5		4 pcs	Leg
6		4 pcs	Floor Glide
7		1 pc	Lift top
8		2 pcs	Lift top hinge
9		1 pc	Electric outlet

Hardware Kit		
No	Description	Qty
A	Bolt M6x50mm	8 pcs
B	Lock washer	8 pcs
C	Washer	8 pcs
D	Allen key	1 pc

I.

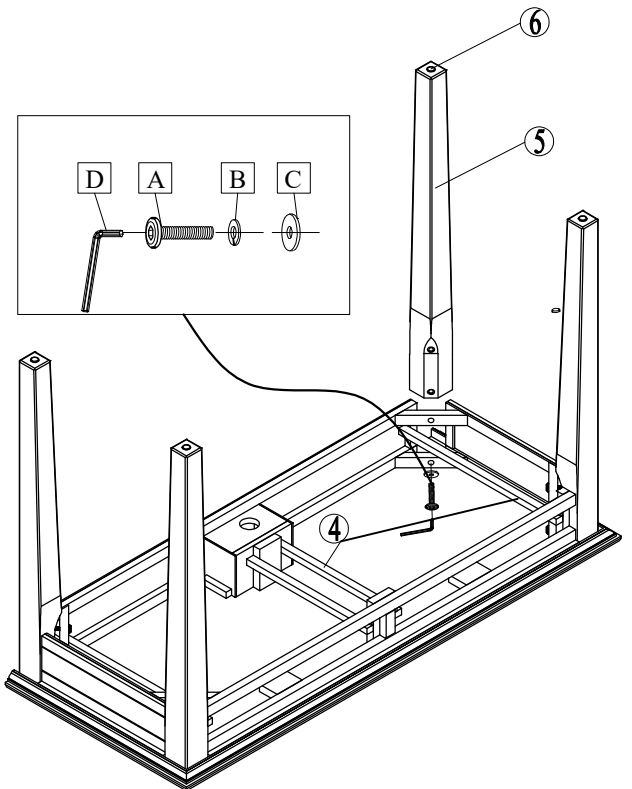
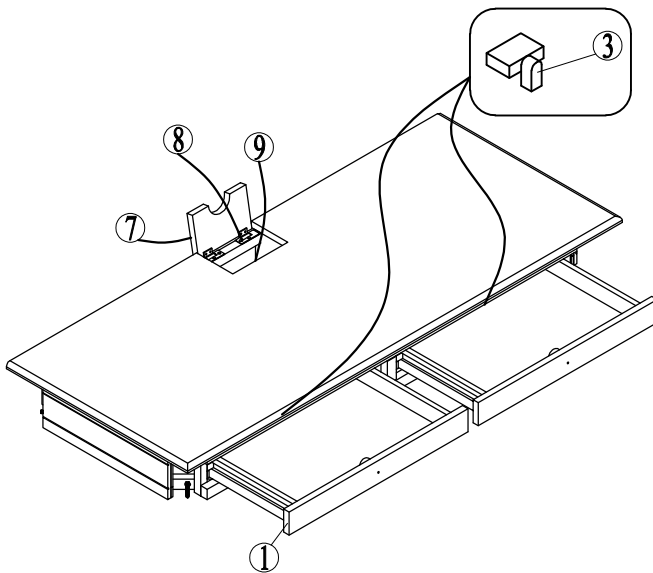

II.

