

POWERED CAROUSEL - POW-CAR-50

APPROX WEIGHT: 446.70 lbs.
 DOES NOT INCLUDE WEIGHT OF POWER OR PACKAGING!!!

*** ANY ADDITIONS, DELETIONS, OR OMISSIONS MUST BE CORRECTED ON THIS DRAWING AS THIS DRAWING WILL BE CONSIDERED ALL INCLUSIVE ***

ALL GRAPHICS PROVIDED ARE FOR REFERENCE ONLY. IF CERTAIN DIMENSIONS ARE CRITICAL PLEASE VERIFY THOSE DIMENSIONS WITH YOUR SALESPERSON

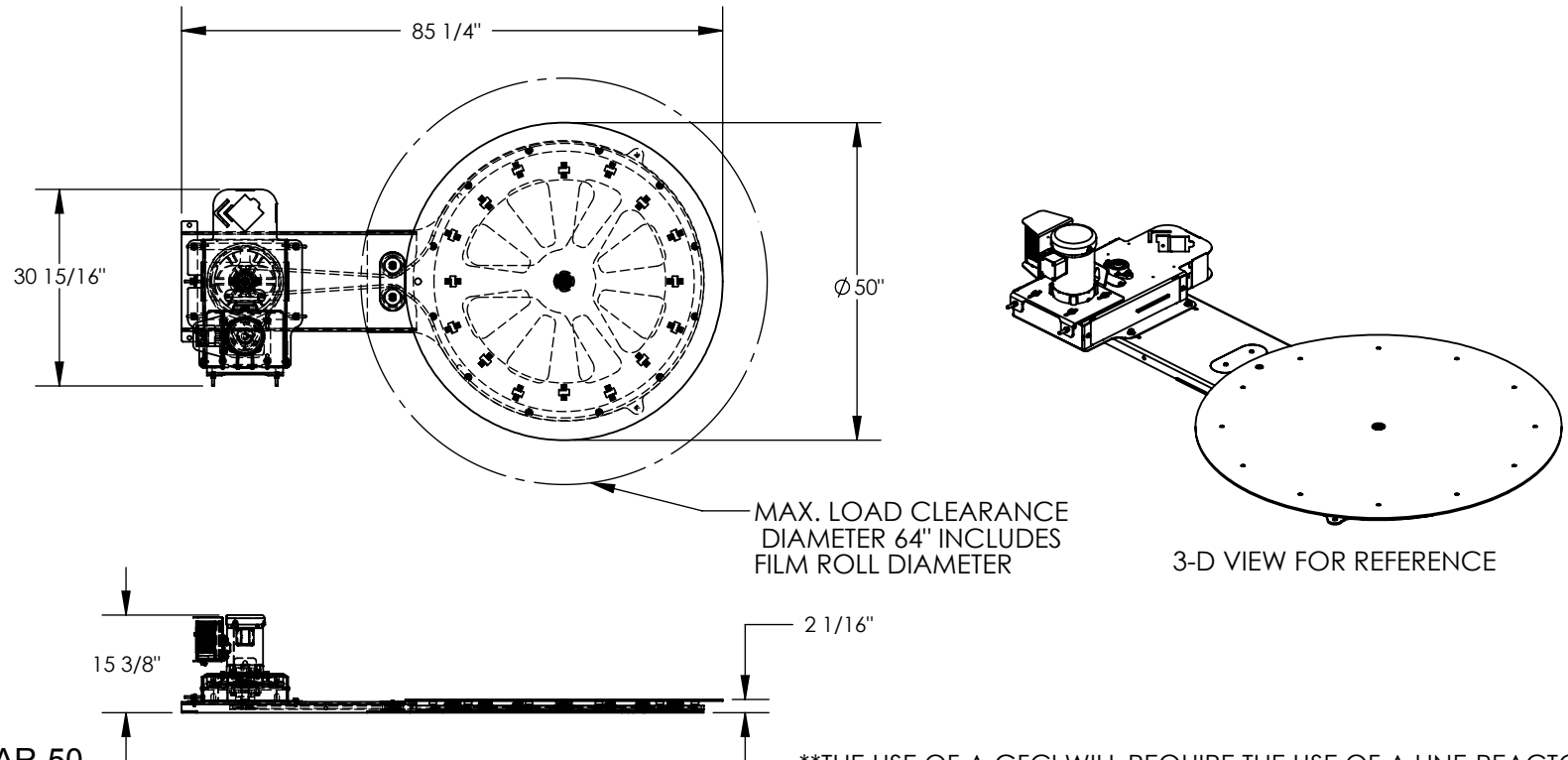

**THE USE OF A GFCI WILL REQUIRE THE USE OF A LINE-REACTOR
 CONSULT YOUR LOCAL ELECTRICAL SUPPLIER FOR DETAILS**

DIMENSION TOLERANCE \pm 1/4"

STANDARD FEATURES

- MODEL NUMBER IS POW-CAR-50
- CAPACITY IS 4000 LBS.
- TURN TABLE DIAMETER IS ϕ 50"
- OVERALL LENGTH IS 85 1/4"
- OVERALL HEIGHT IS 15 3/8"
- TURN TABLE DECK HEIGHT IS 2 1/16"
- POWER INPUT IS 115 V 1-PHASE
- BELT DRIVEN
- VARIABLE SPEED TURN TABLE (3-12 RPM)
- WITH SOFT START/STOP
- FOOT CONTROL FOR TURN TABLE ROTATION
- DECK IS TOUGH BAKED IN POWDER COAT YELLOW FINISH
- FRAME IS TOUGH BAKED IN POWDER COAT BLUE FINISH

SPECIAL FEATURES

NONE

APPROVAL	I, THE UNDERSIGNED, AGREE THAT THE PRODUCT AS REPRESENTED SATISFIES DESIGN AND DIMENSION REQUIREMENTS. I ALSO ACKNOWLEDGE MY DUTY TO CONFIRM PRODUCT AND INSTALLATION COMPLIANCE WITH ALL APPLICABLE FEDERAL, STATE AND LOCAL REGULATIONS AND STANDARDS.	
	ANY MODIFIED UNITS ARE NON-RETURNABLE	
	[] As drawn [] As marked	
	Signed: _____ Date: _____	
Printed Name: _____		
<i>LEAD TIME WILL START UPON RECEIPT OF SIGNED APPROVAL DRAWING</i>		

FOR INTERNAL USE ONLY PROJECT SIGN OFF	
SALES	
ENG.	
FAB.	
POWER	

DISTRIBUTOR'S NAME:		P.O.#
VESTIL MANUFACTURING		X
DRAWN BY: SJA		W.O.#
DATE: 12/02/2014		X
REFERENCE: X	SCALE: 1:30	SALES: X
QUOTED LEAD TIME: X	QUOTE #	FILE NAME:
	X	20-007-150