

NOTICE DE MONTAGE
ASSEMBLING INSTRUCTIONS
MONTAGEANLEIUNG
MANUAL DE MONTAJE
MONTAGEVOORSCHRIFT
INSTRUÇÕES DE MONTAGEM
ISTRUZIONI DI MONTAGGIO
ИНСТРУКЦИЯ ПО СБОРКЕ
Naputci za montažu

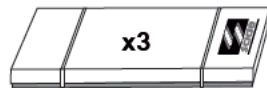

Package 1: 19 Kg
Package 2: 26 Kg
Package 3: 26 Kg

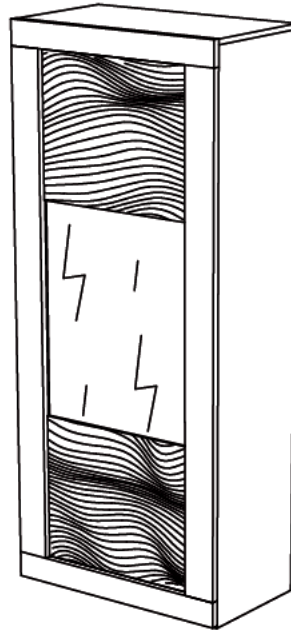
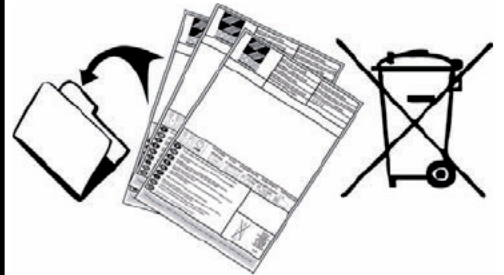

F POUR L'APRES-VENTE, RETOURNEZ AU MAGASIN AVEC CETTE NOTICE

GB FOR THE AFTER SALES, GO BACK TO THE SHOP WITH THIS ASSEMBLY INSTRUCTION

D WENDEN SIE SICH BITTE AN IHREN HANDLER UND GEBEN SIE IHM DIE KENNUNMER DES MOBELS UND DIE TEILNUMMER

E EN CASO DE SERVICIO POST-VENTA DEBEN DE VOLVER A LA TIENDA CON LAS INSTRUCCIONES DE MONTAJE

NL VOOR SERVICE NA VERKOOP, GA NAAR UW LEVERANCIER MET DEZE MONTAGE HANDLEIDING

P PARA O POS VENDA, VOLTE A LOJA COM ESTA FOLHA

I SERVIZIO POST VENDITA: E NECESSARIO PRESENTARSI SUL PUNTO VENDITA CON QUESTE ISTRUZIONI DI MONTAGGIO

RU ДЛЯ ПОСЛЕПРОДАЖНОГО ОБСЛУЖИВАНИЯ ПРОСЬБА ОБРАТИТЬСЯ В МАГАЗИН ПРЕДЪЯВИВ НАСТОЯЩУЮ ИНСТРУКЦИЮ ПО СБОРКЕ

HR U SLUČAJU REKLAMACIJE, VRATITE SE NA PRODAJNO MJESTO S OVM UPUTAMA ZA MONTAŽU

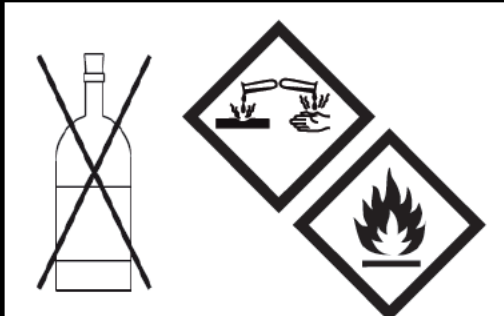
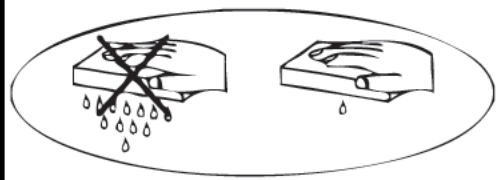

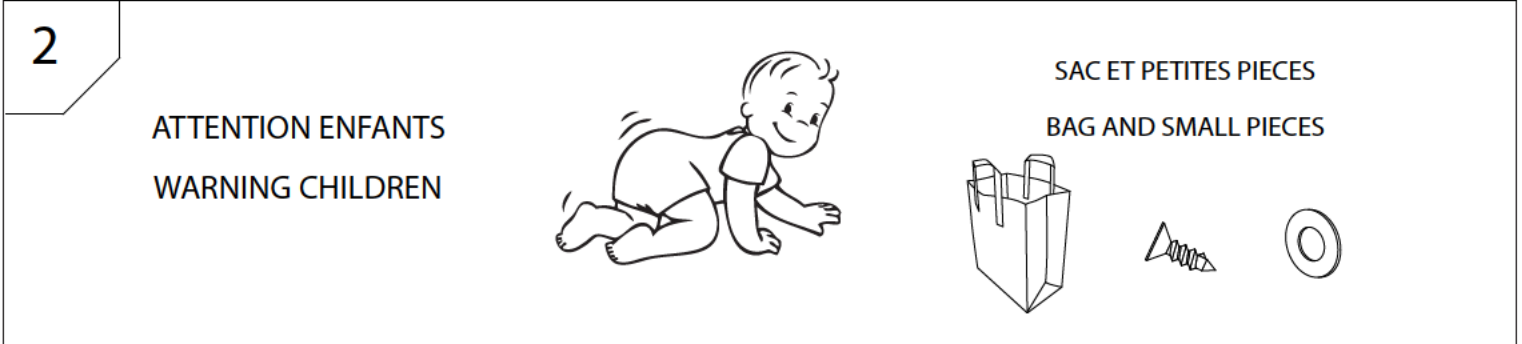
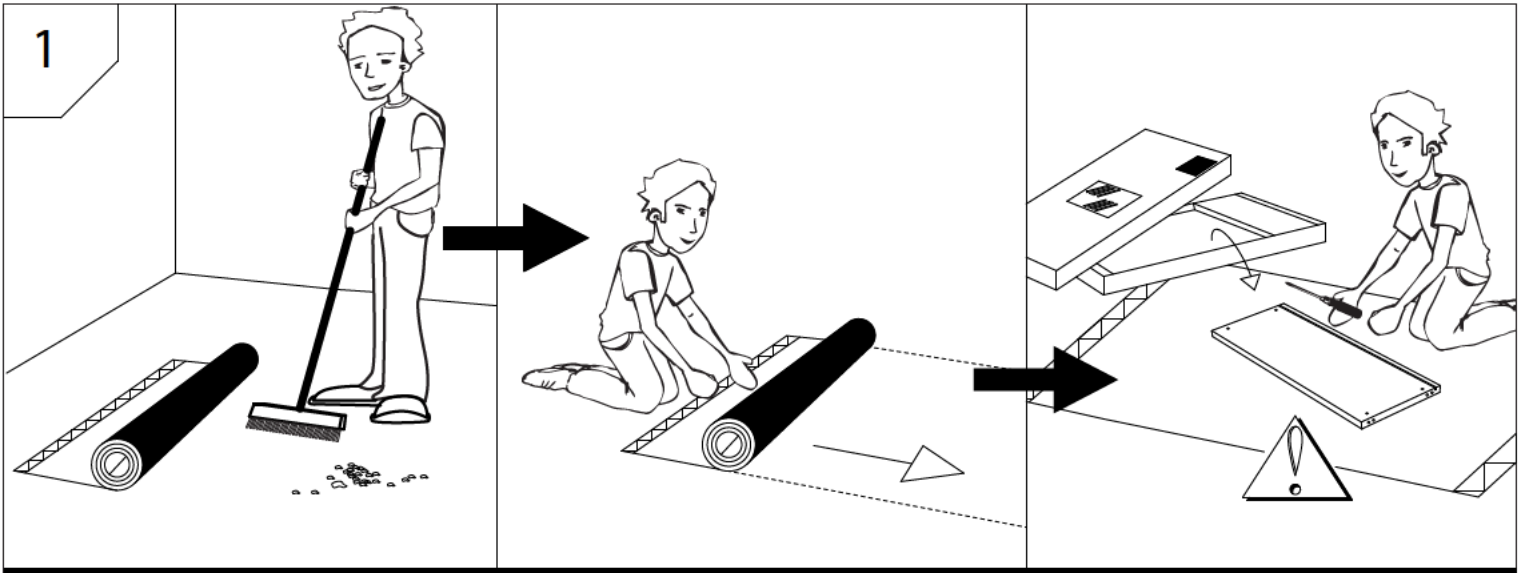

3

OUTILLAGES	TOOLS	HANDWERKZEUGE	HERRAMIENTA	GEREEDSCHAP
FERRAMEN	ATTREZZATURE	ИНСТРУМЕНТЫ ДЛ ЯБОРКИ		工具

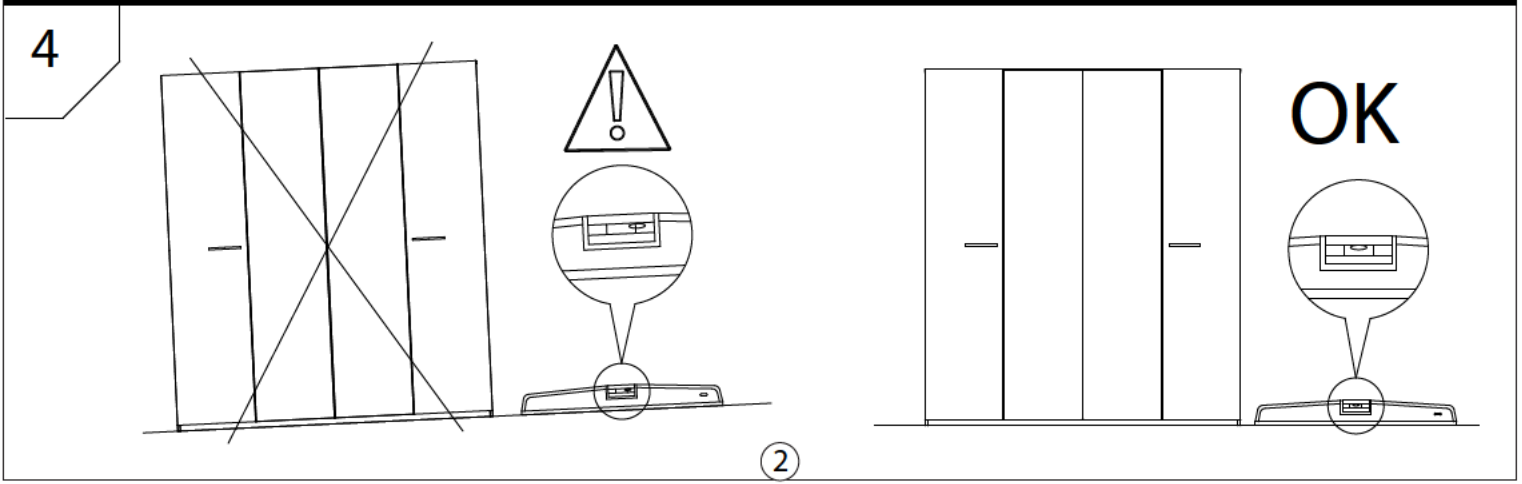
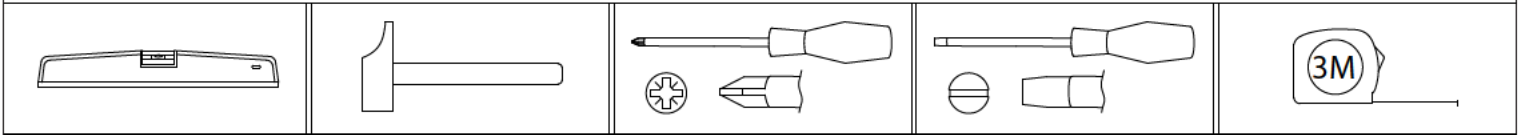
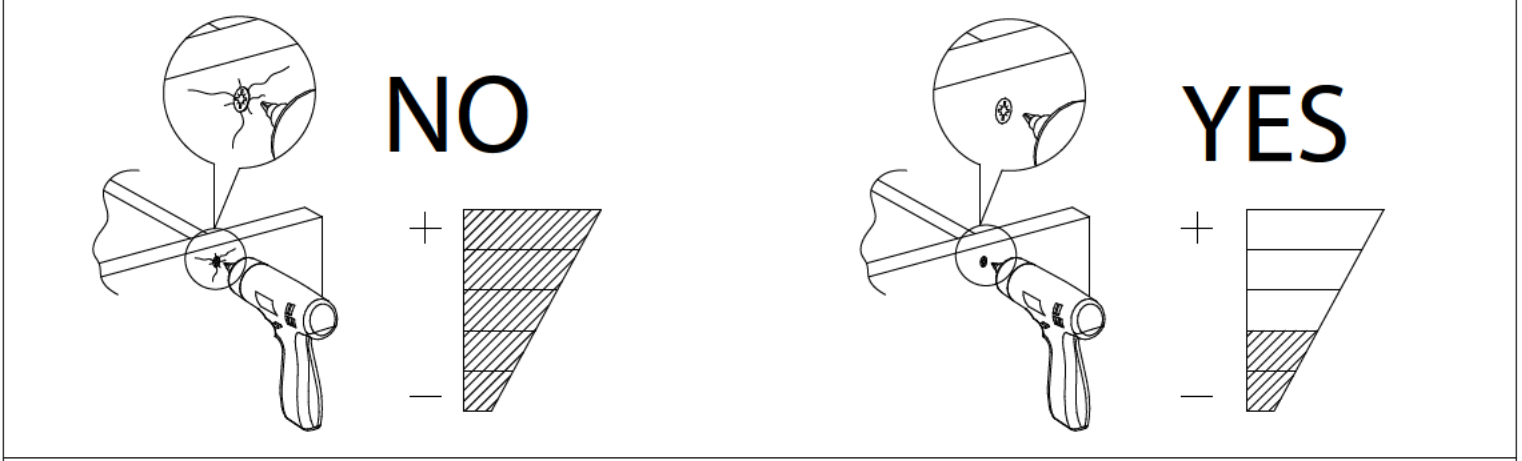

5

T4 - x8
G1 - x7

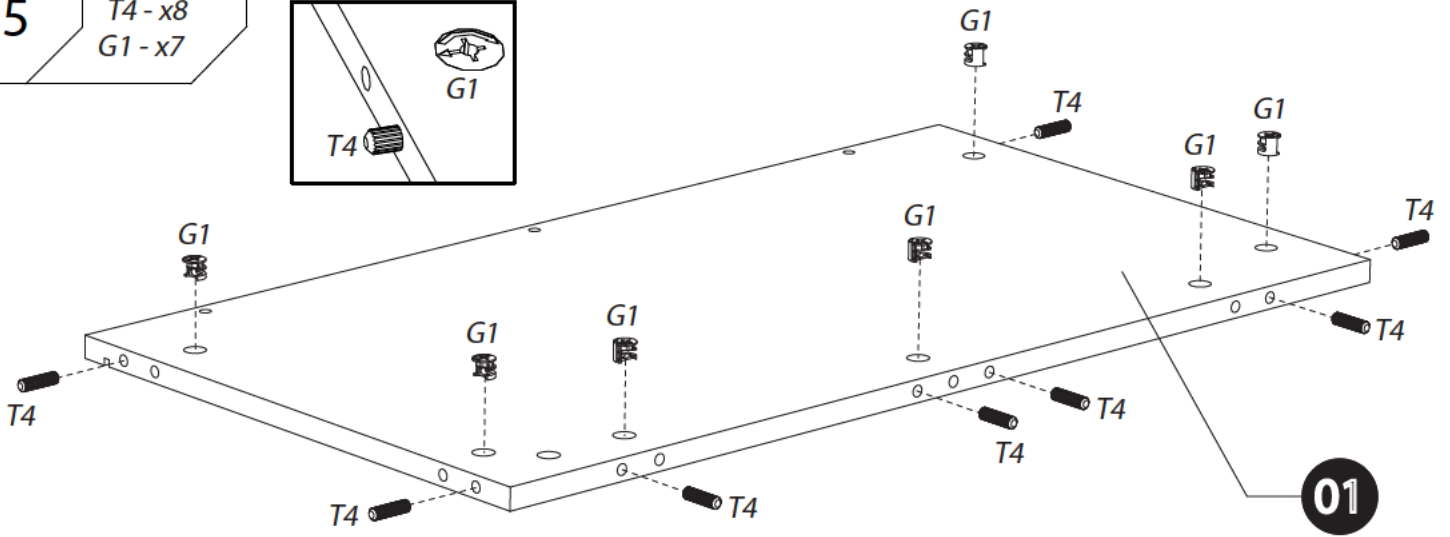
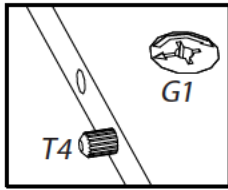

6

A6 - x3

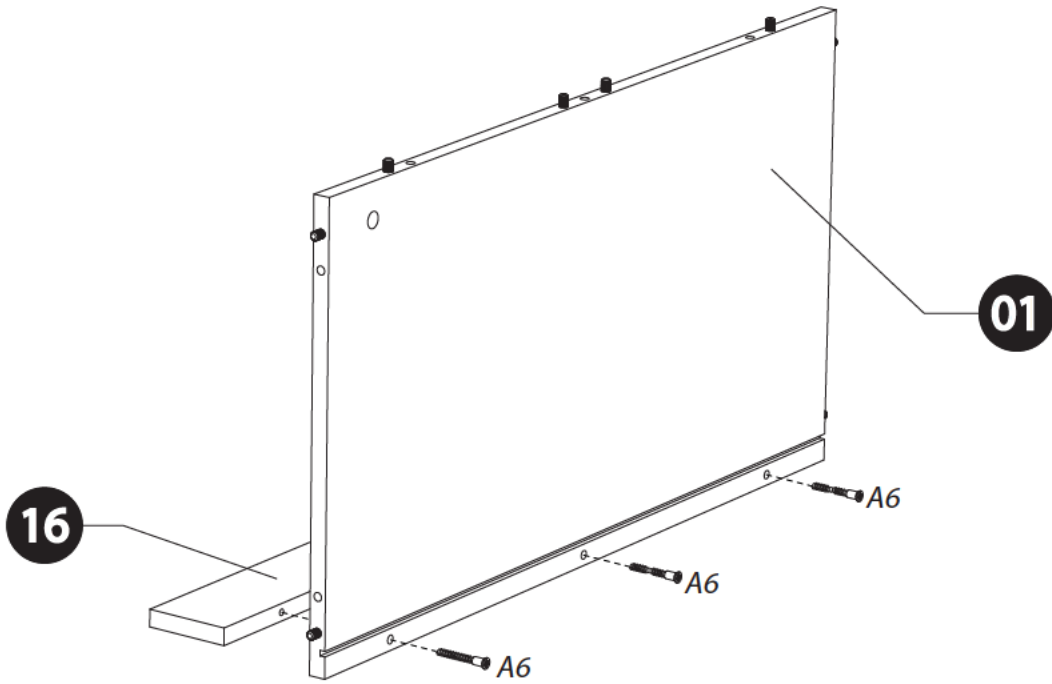

7

T4 - x4 J7 - x2
G1 - x5 W2 - x1
G4 - x8

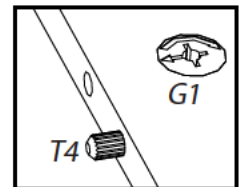
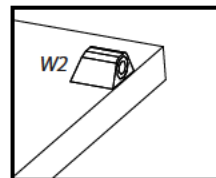
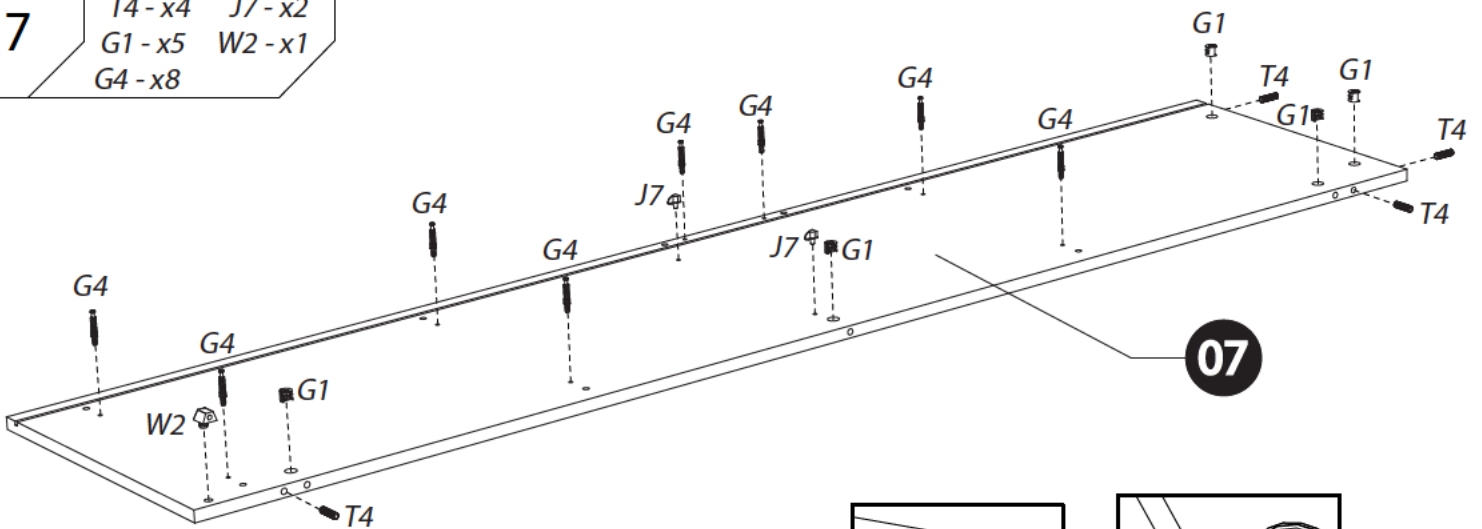

8

T4 - x4 J7 - x2
G1 - x5 W2 - x1
G4 - x8

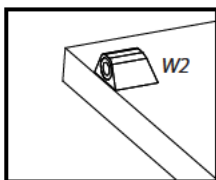
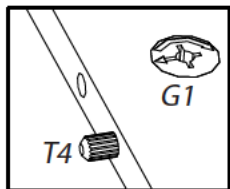
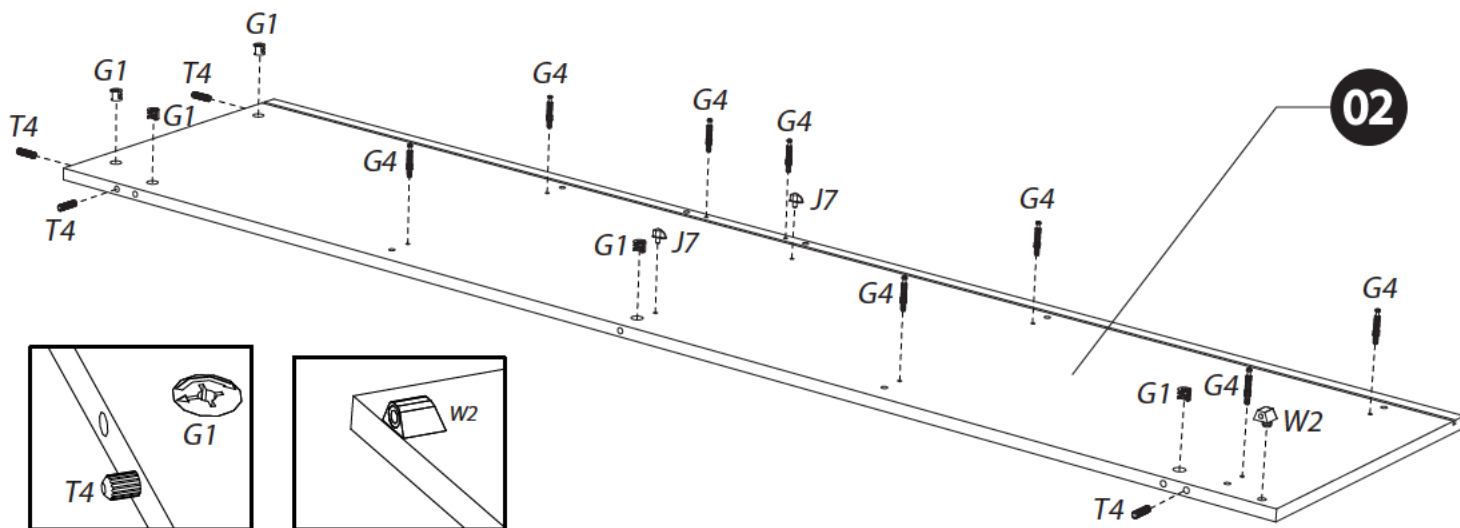

9

x2

T4 - x4
G1 - x4

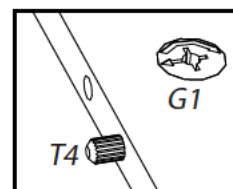
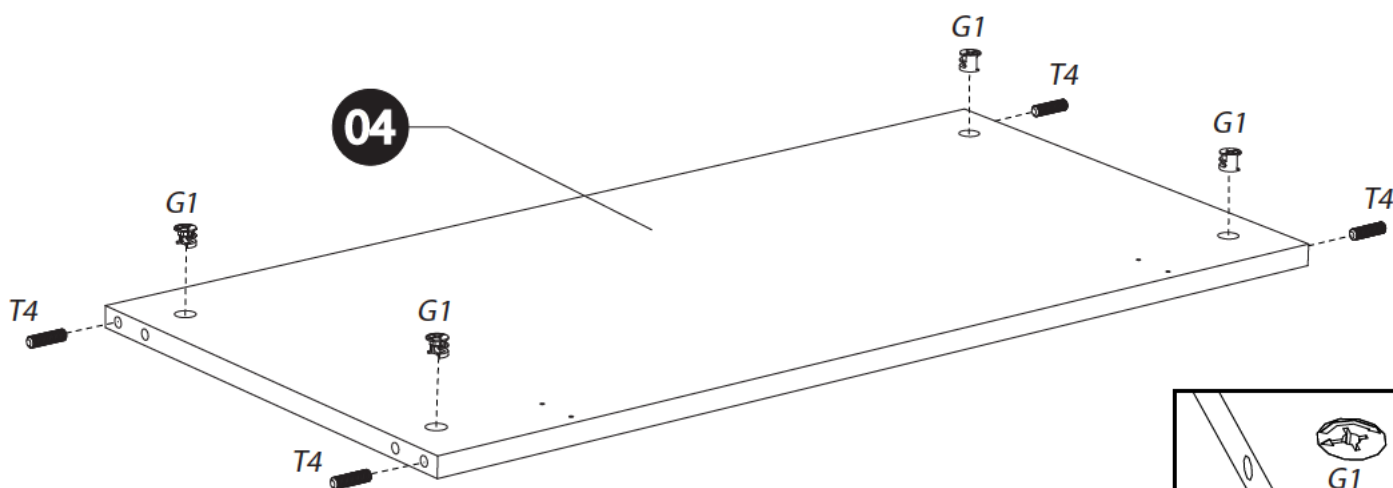

10

T4 - x4
G1 - x4

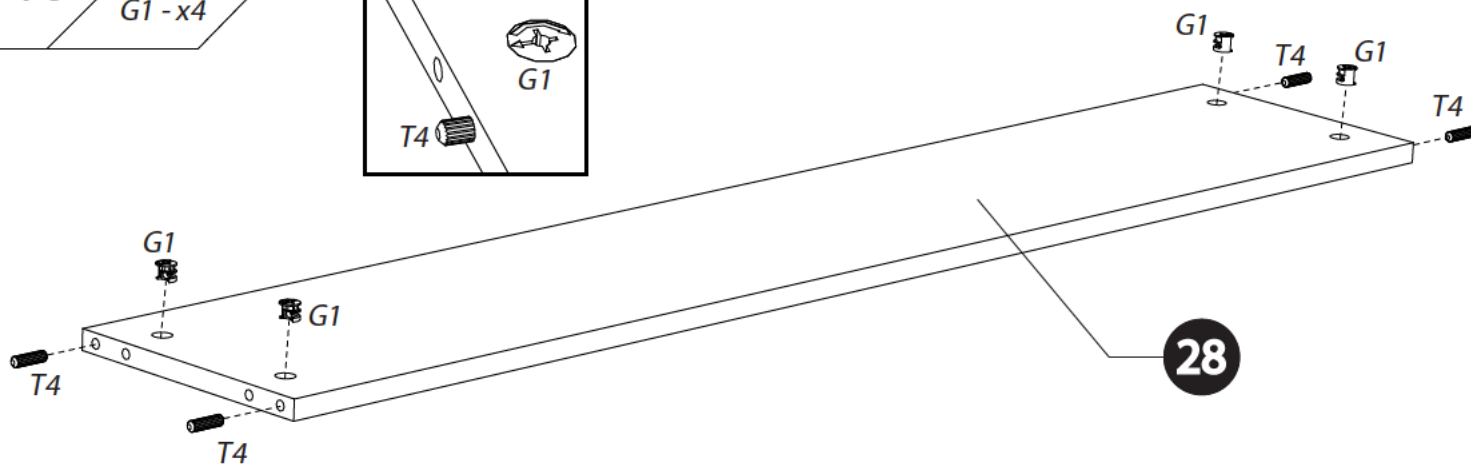
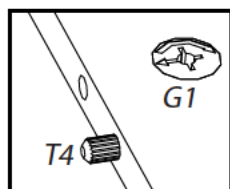

11

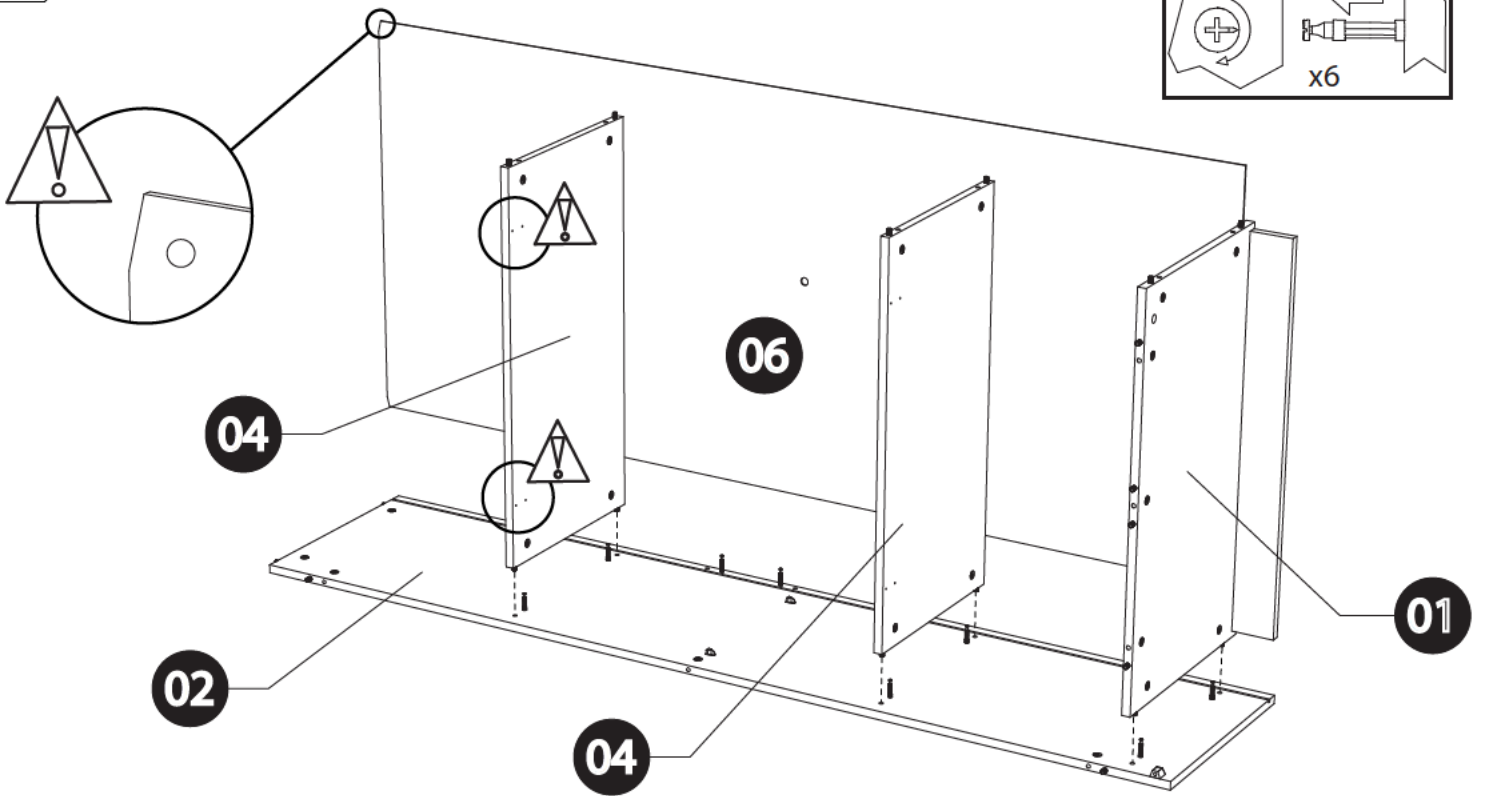

12

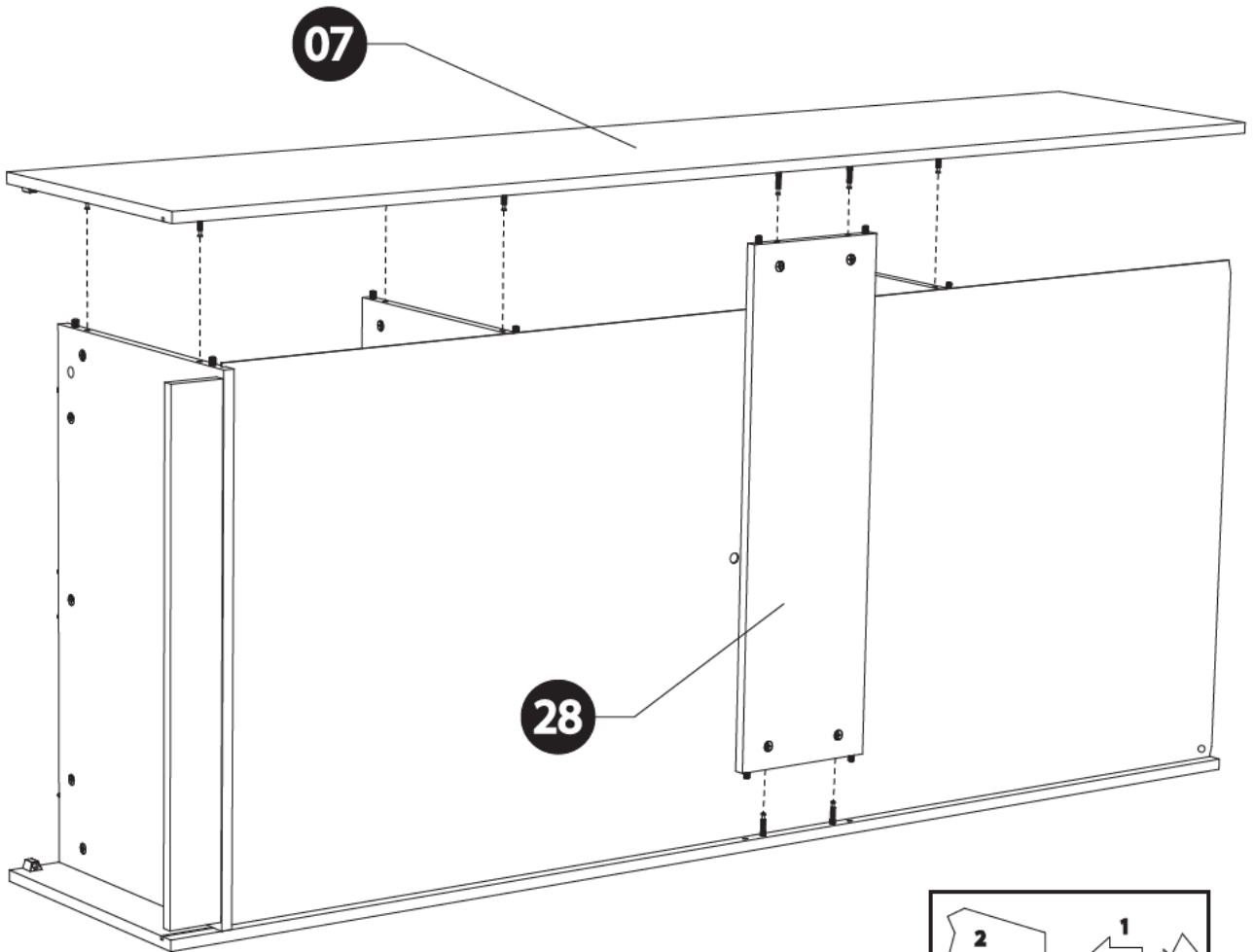

13

T4 - x4
G1 - x3
G4 - x4

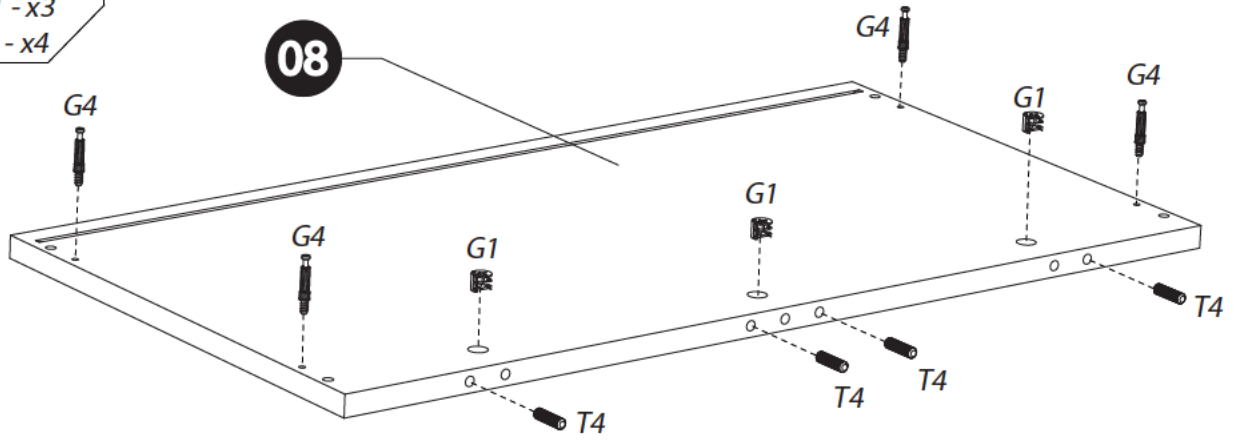

14

08

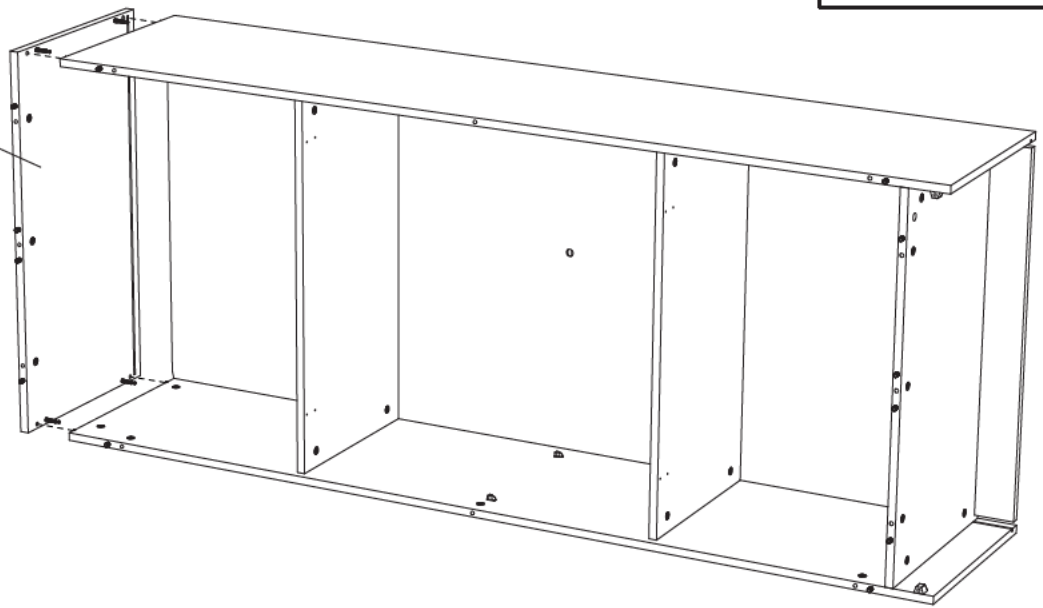
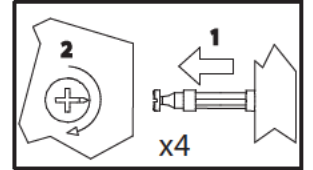

15

W1 - x10

W1

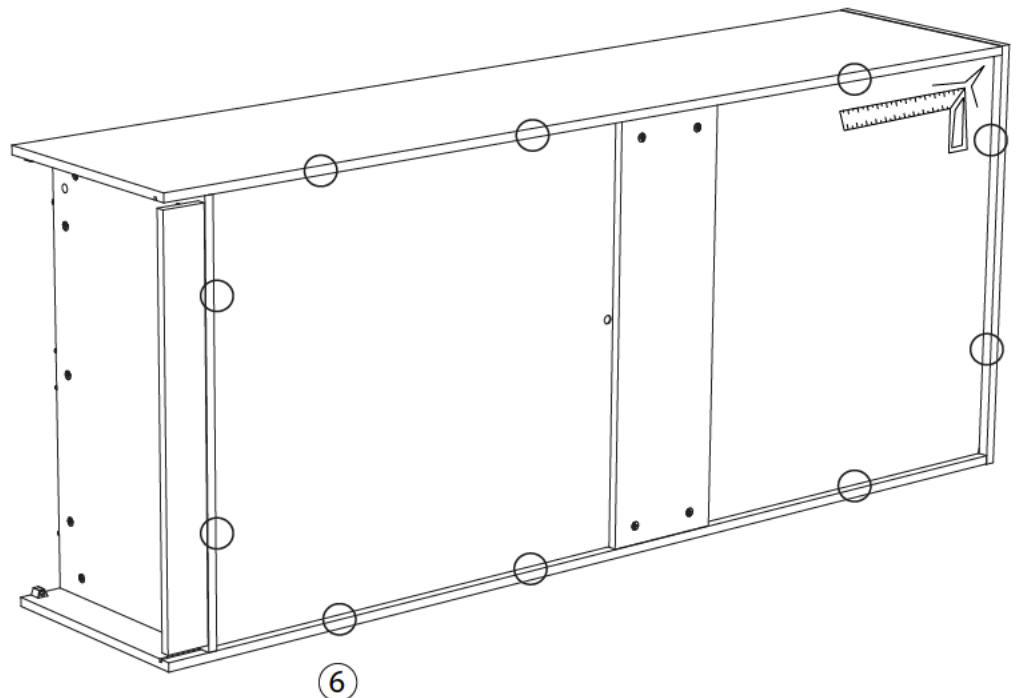
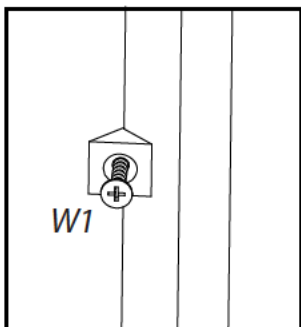

16

x2

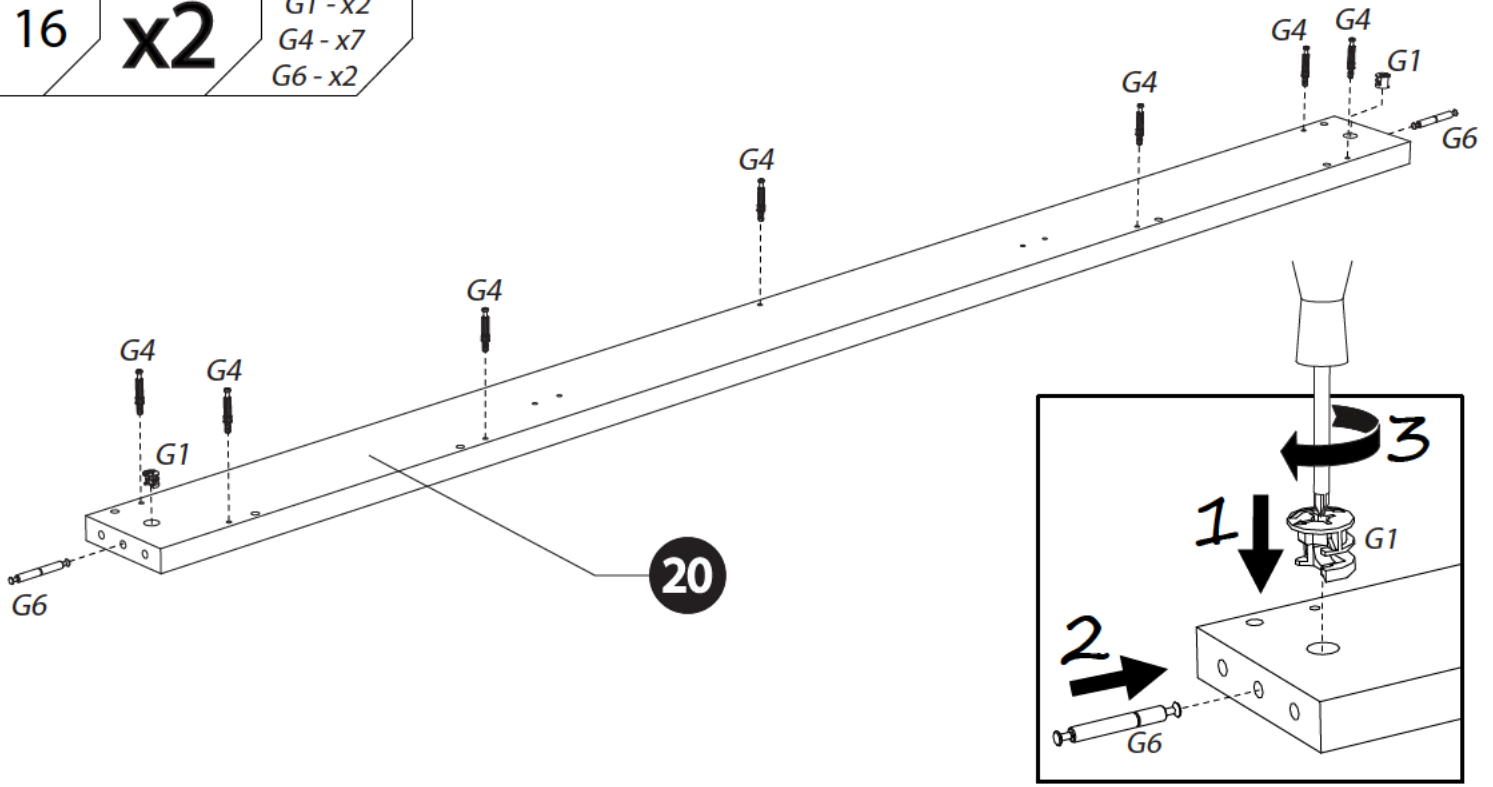
G1 - x2
G4 - x7
G6 - x2

17

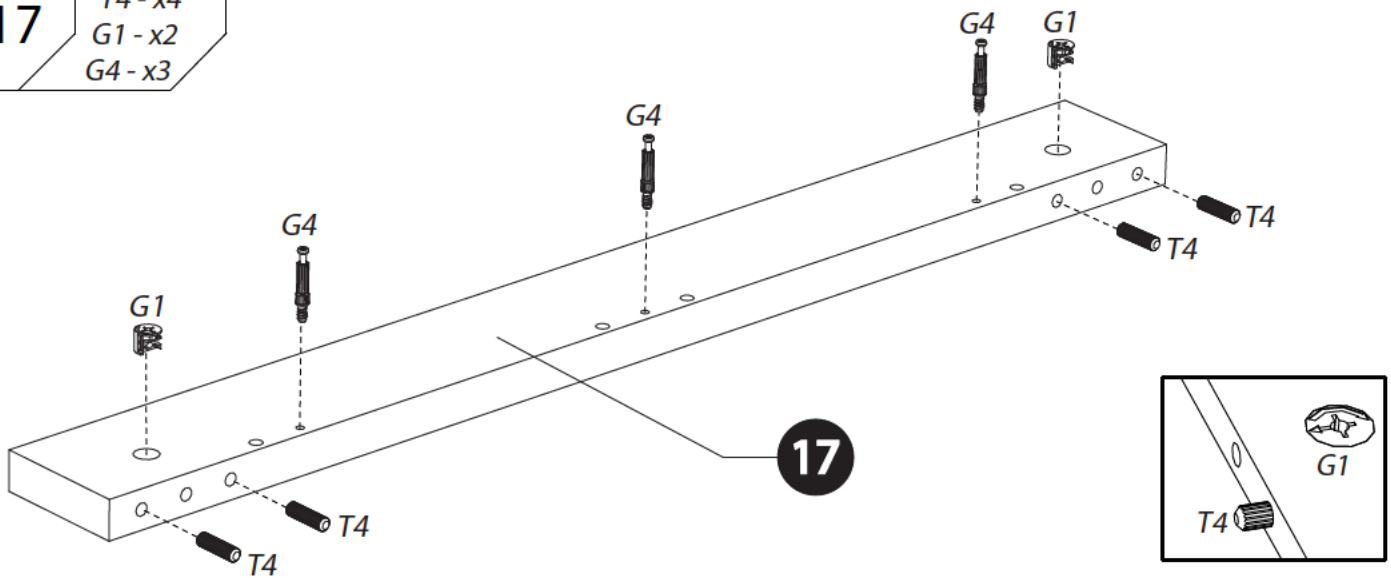
T4 - x4
G1 - x2
G4 - x3

18

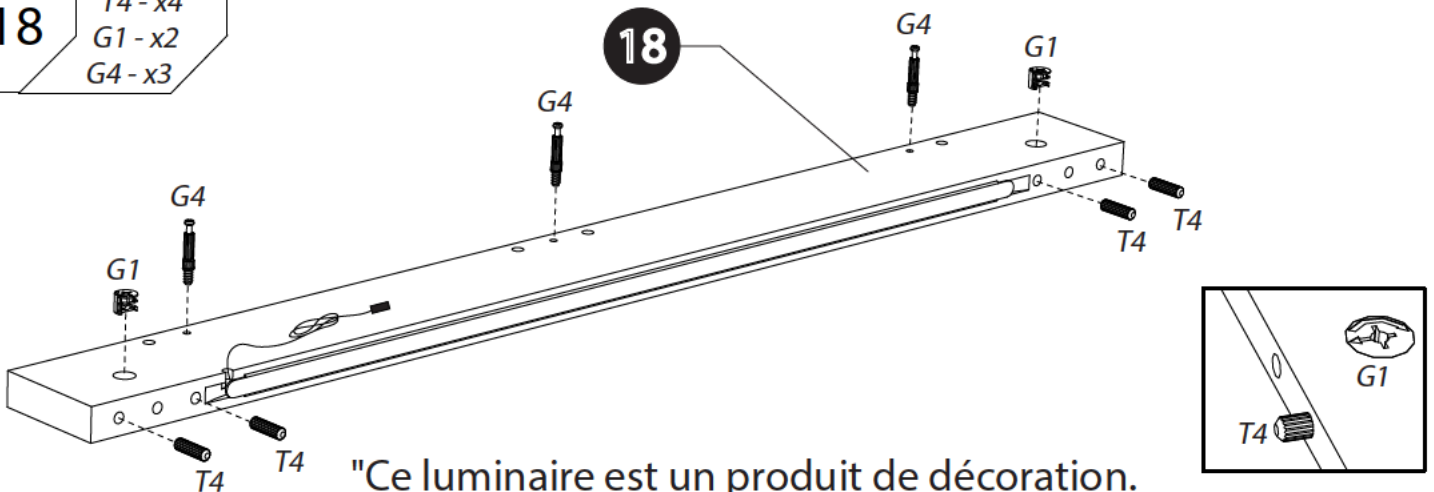
T4 - x4
G1 - x2
G4 - x3

"Ce luminaire est un produit de décoration.
Ce luminaire ne convient pas pour l'illumination
d'une pièce d'un ménage."

19

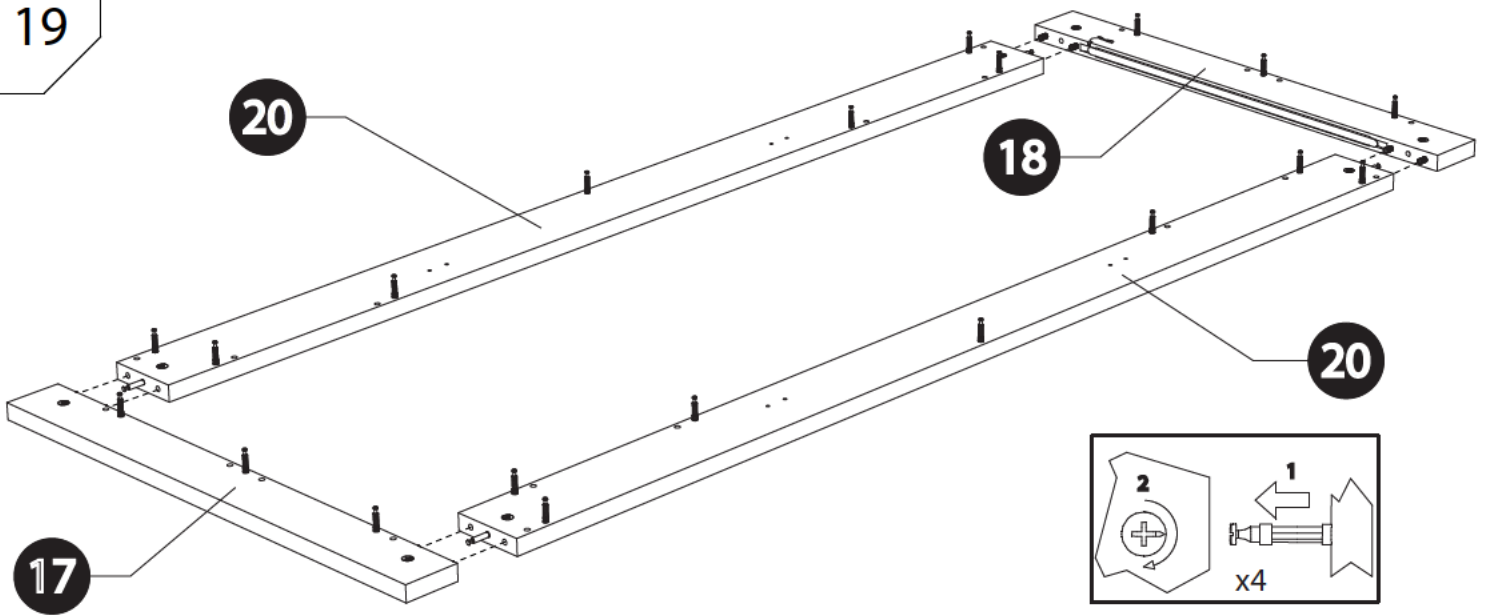

20

x2

G1 - x2
T4 - x2
W2 - x1

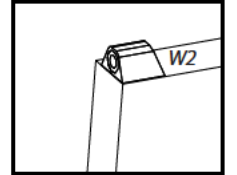
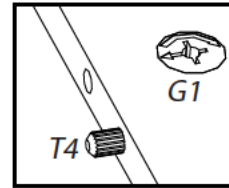
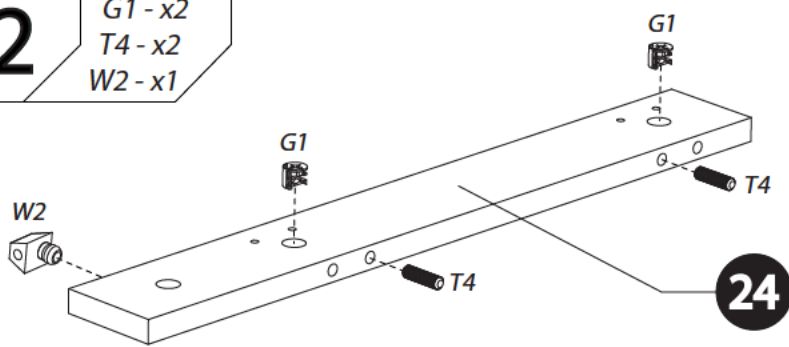

21

x2

G1 - x2
T4 - x2
W2 - x1

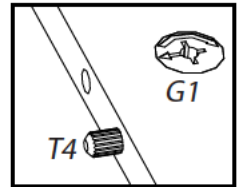
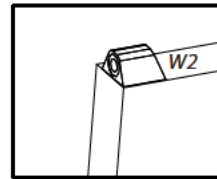
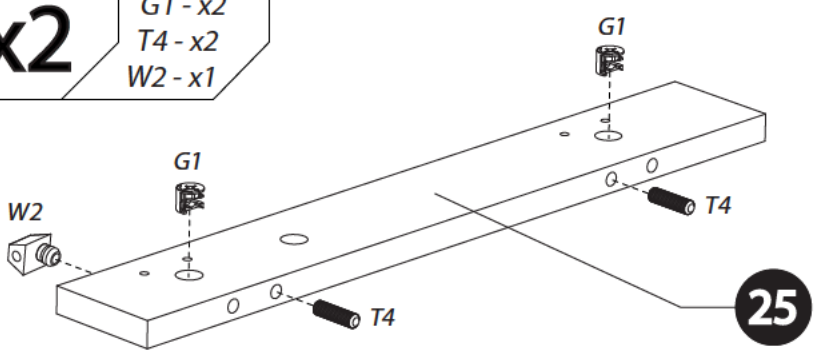

22

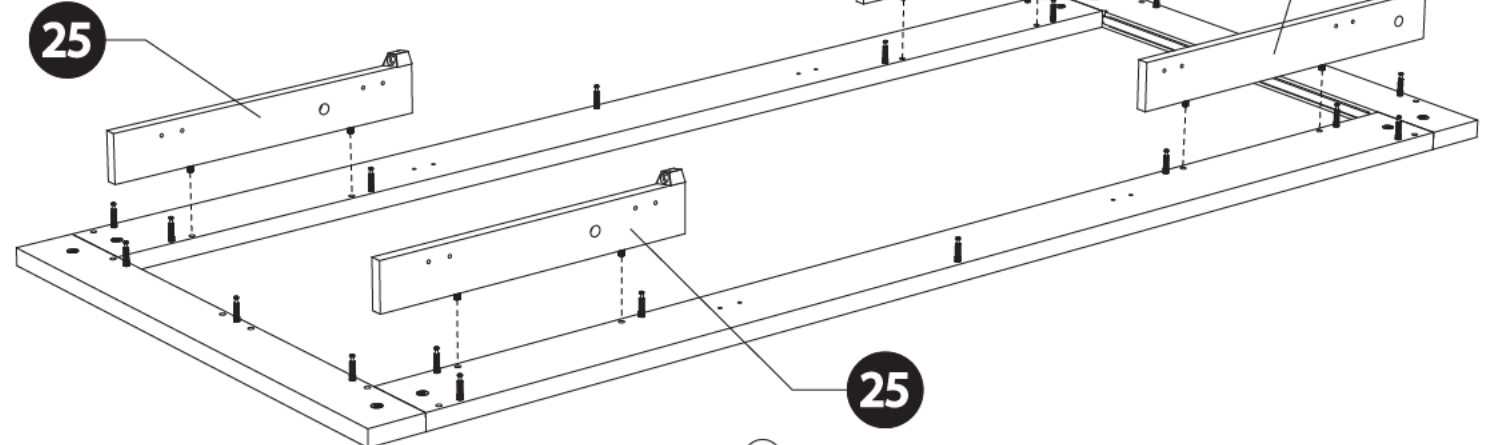
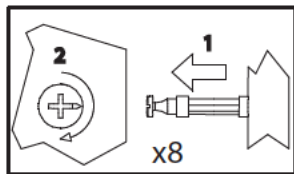

23

V9-x6

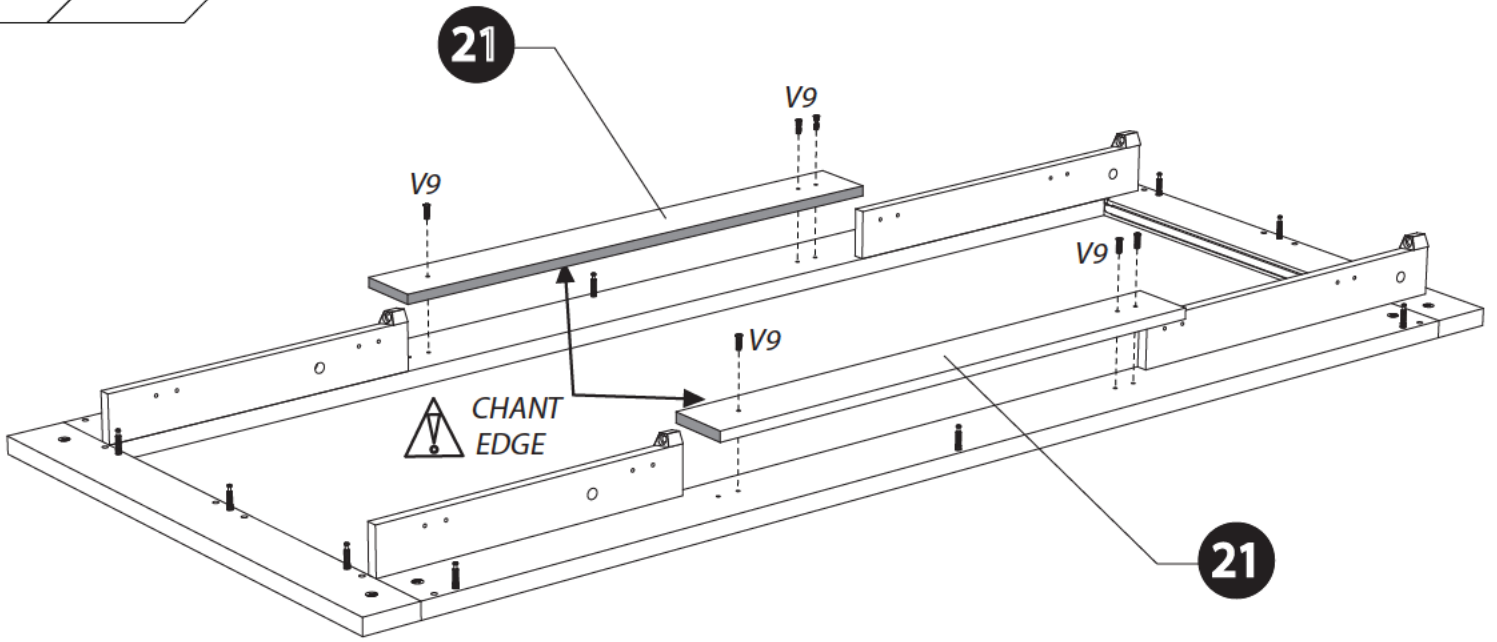

24

F16-x1

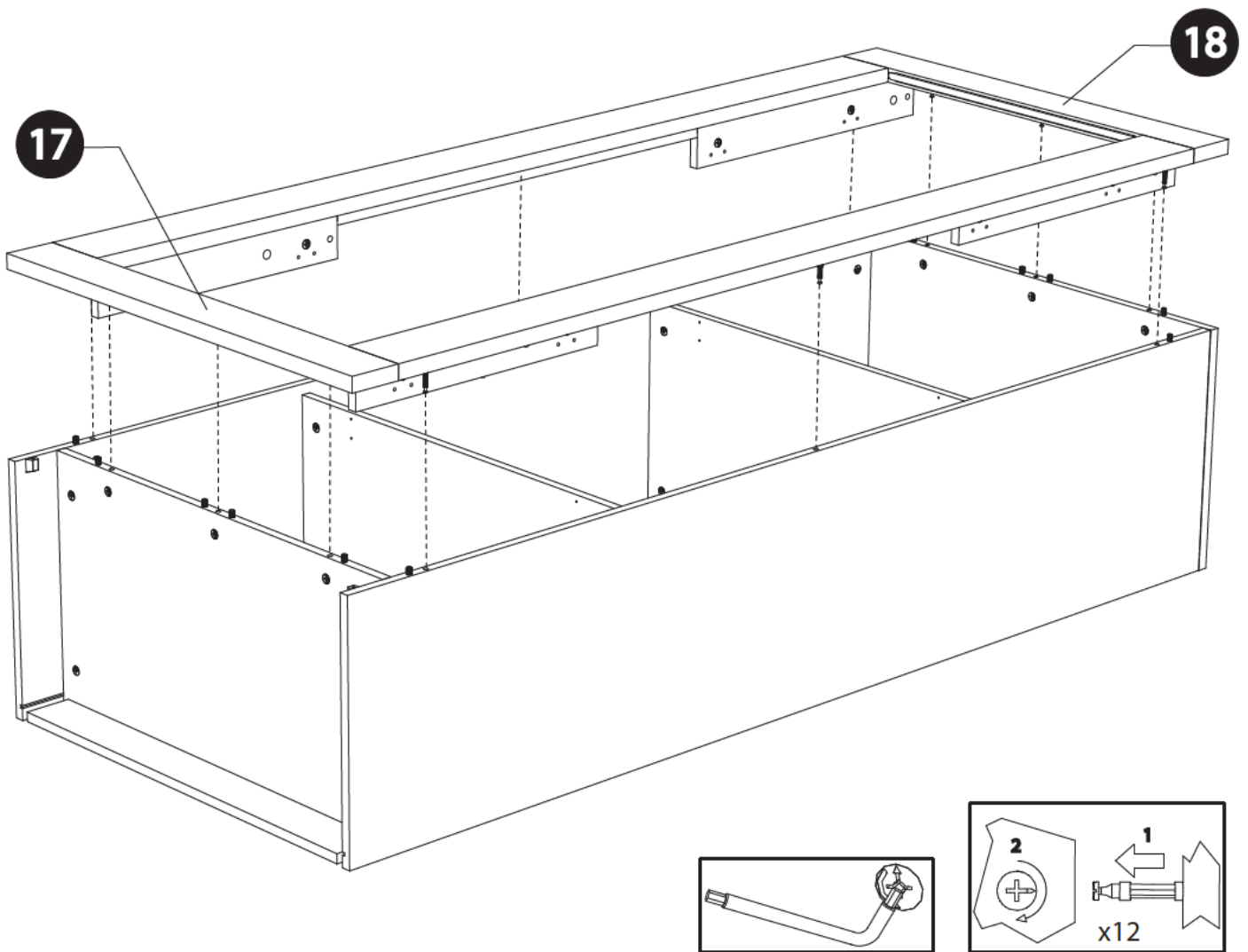

EAC

CE



LED



F

INSTRUCTION GÉNÉRALE DU LUMINAIRE

REMARQUES

SCIAE Dienville n'est pas responsable des dommages résultant :

- d'un mauvais montage
- de l'emploi d'outils inappropriés
- de changements techniques de l'ensemble
- du non-respect de cette instruction.

A LIRE AVANT DE PROCEDER AU MONTAGE

L'ensemble est conçu pour une tension d'alimentation de 230V ~ 50Hz,

il est fait en 2e classe de protection et marqué par un symbole  approprié.

L'indice de protection de l'ensemble : IP20

Brancher l'ensemble à une prise de 230V ~ 50Hz en bon état de fonctionnement.

Le montage doit être effectué conformément à l'instruction.

ATTENTION !

Lors du montage, il faut strictement débrancher l'ensemble du courant 230V ~ 50Hz, respecter les règles de sécurité et rester particulièrement prudent.

La puissance électrique totale des montures de l'ensemble ne peut pas dépasser la puissance nominale du chargeur.

Les montures désignées par le symbole  doivent être installées sur une surface incombustible.

Pour nettoyer, il faut utiliser uniquement un chiffon sec et ne jamais utiliser de produits chimiques.

MONTAGE

Effectuer le montage dans l'ordre conforme au mode d'emploi.

Il faut s'assurer que toutes les connexions électriques et les fixations soit effectuées correctement, de façon à exclure tout fonctionnement défectueux.

Lors du déplacement des meubles, veillez particulièrement à ne pas endommager l'isolation des câbles électriques de l'ensemble.

EN

GENERAL LUMINAIRE INSTRUCTION

NOTES

SCIAE Dienville is not liable for any damage resulting from :

- a bad assembly
- the use of inappropriate tools
- of technical changes to the whole
- for non-compliance with this instruction.

TO BE READ BEFORE ASSEMBLY

The unit is designed for a supply voltage of 230V ~ 50Hz,

it is made in 2nd protection class and marked with an appropriate symbol .

The protection index of the set : IP20

Connect the unit to a 230V ~ 50Hz socket in good working order.

Installation must be carried out in accordance with the instructions.

ATTENTION !

During installation, the entire 230V ~ 50Hz power supply must be strictly disconnected, respect the safety rules and remain particularly careful.

The total electrical power of the frames in the set may not exceed the charger's power rating.

Frames marked with the symbol  must be installed on a non-combustible surface.

To clean, use only a dry cloth and never use chemicals.

ASSEMBLY

Carry out the assembly in the order described in the operating instructions.

Make sure that all electrical connections and fixings are carried out correctly, so that faulty operation is excluded.





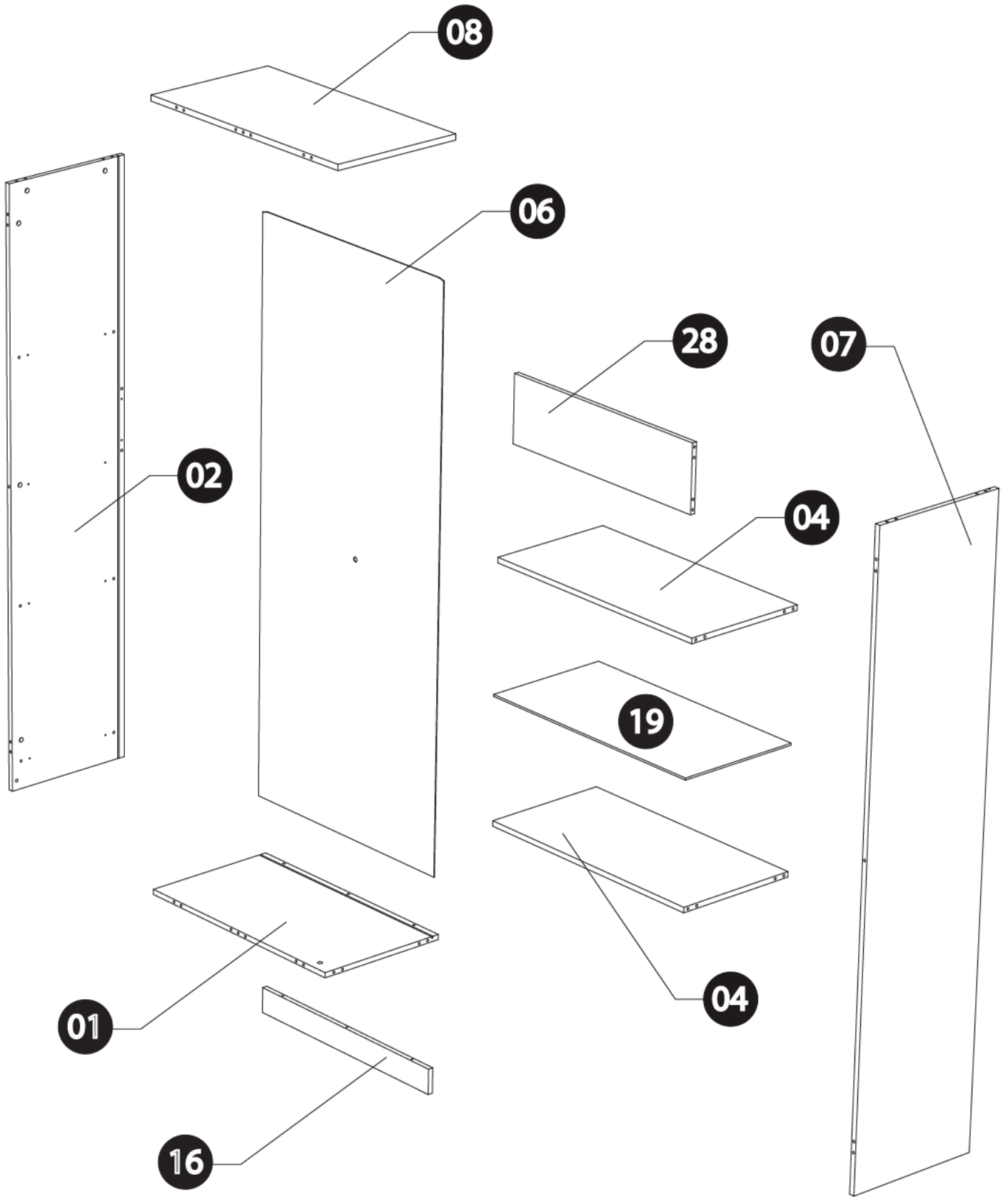

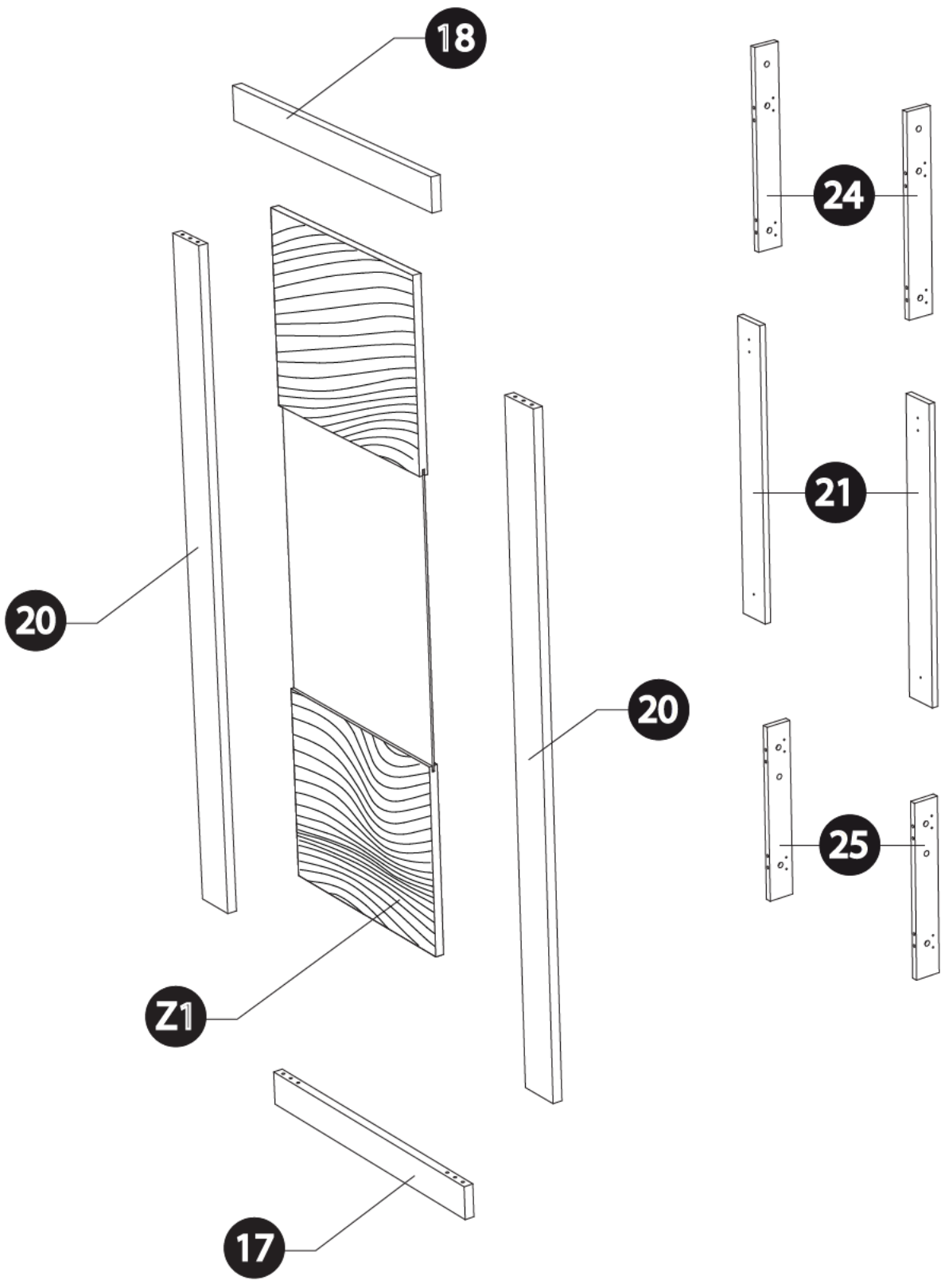

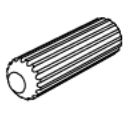
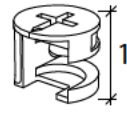

When moving the furniture, be particularly careful not to damage the following when moving it the insulation of the electric cables of the whole.

Ⓕ	NUMERO	NOM DE LA PIECE	QUANTITE	COLIS
Ⓖ	NUMBER	NAME OF THE PIECE	QUANTITY	PARCEL
Ⓓ	NUMMER	NAME DER TEILE	MENGE	PAKET
Ⓔ	NUMERO	NOMBRE DE LA PIEZA	CANTIDAD	PAQUETE
Ⓝ	NUMMER	NAAM VAN HET ARTIKEL	AANTAL	COLLI
Ⓟ	NUMERO	NOME DA PECA	QUANTIDADE	PACOTE
Ⓡ	NUMERO	NOME DEL PEZZO	QUANTITA	COLI
Ⓡ	НОМЕР	НАЗВАНИЕ ДЕТАЛ И	КОЛИЧЕСТВО	УПАКОВОЧНОЕ МЕСТО
Ⓒ	数字	部件名称	数量	包裹
	1	Dessous	1	2
	2	Côté gauche	1	2
	4	Intermédiaire	2	1
	6	Derrière	1	3
	7	Coté droit	1	2
	8	Dessus	1	2
	Z1	Porte glace	1	3
	16	Derrière de socle	1	1
	17	Face de socle	1	1
	18	Bandeau de dessus	1	1
	19	Tablette verre	1	1
	20	Montant de côté	2	3
	21	Recharge de montant	2	1
	24	Recharge haute d'embases	2	1
	25	Recharge basse d'embases	2	1
	28	Raidisseur	1	1
		QUINCAILLERIE-FITMENT BESCHLAGBEUTEL-HERRAJES VERBINDING-QUINQUILHARIA FERRAMENTA-ФУРНИТУРА-配件	3	1



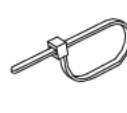

Quincaillerie - Fitment - Beschlagbeutel - herrajes
 Verbindung - Quinquilharia - Ferramenta - 配件 - ΟΥΡΗ ΤΥΡΑ

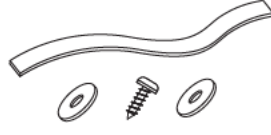
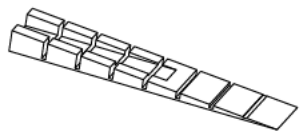
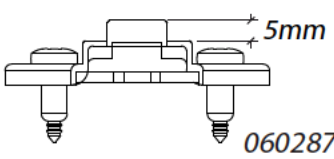
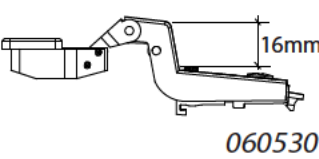
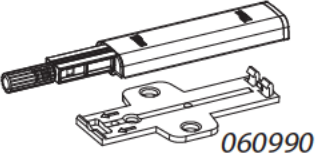
<p>T4 - x48</p>  <p>081500</p>	<p>G1 - x48</p>  <p>067119</p>	<p>G4 - x40</p>  <p>067120</p>	<p>G6 - x4</p>  <p>067248</p>	<p>A6 - x3</p>  <p>062166</p>	<p>W1 - x10</p>  <p>061074</p>	<p>J7 - x4</p>  <p>060949</p>	<p>W2 - x6</p>  <p>061215</p>
<p>U6 - x8</p>  <p>060642</p>	<p>W14 - x5</p>  <p>063501</p>	<p>W13 - x5</p>  <p>063500</p>	<p>F16 - x1</p>  <p>060400</p>	<p>W23 - x1</p>  <p>060690</p>	<p>W4 - x2</p>  <p>061415</p>		
<p>E4 - x4</p>  <p>060287</p>	<p>D3 - x4</p>  <p>060530</p>	<p>N7 - x1</p>  <p>060990</p>					

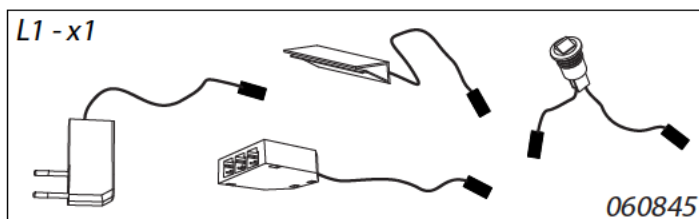
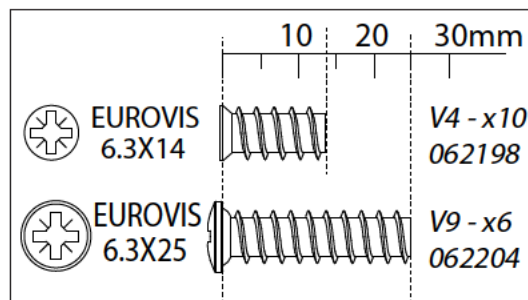
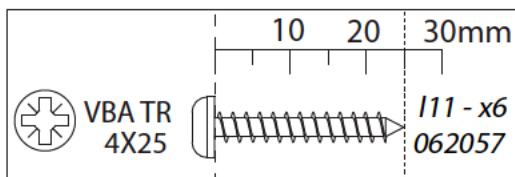

25

111 - x6

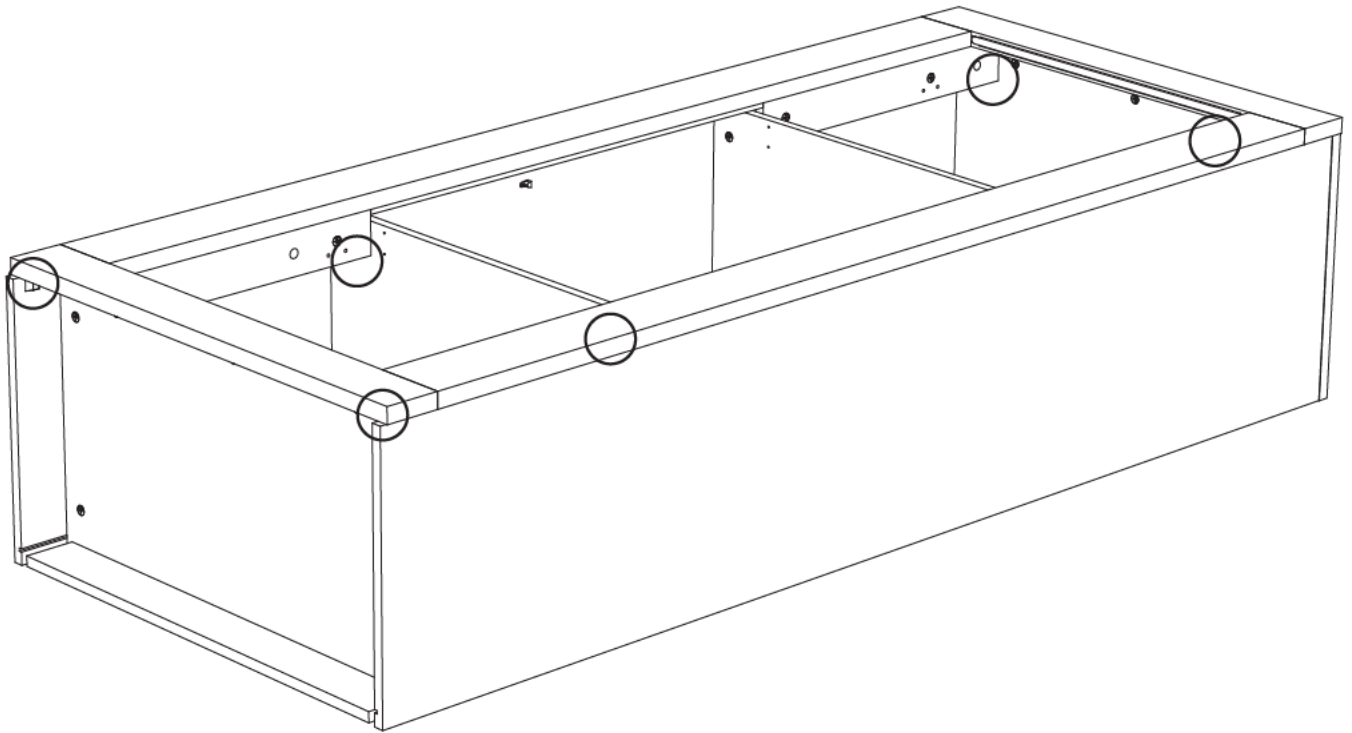
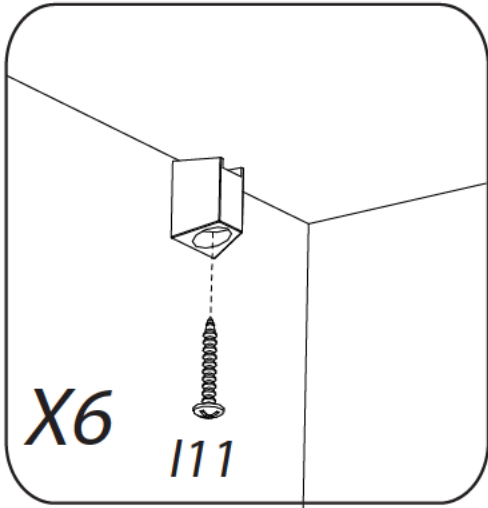

26

L1 - x1
W13 - x3
W14 - x3

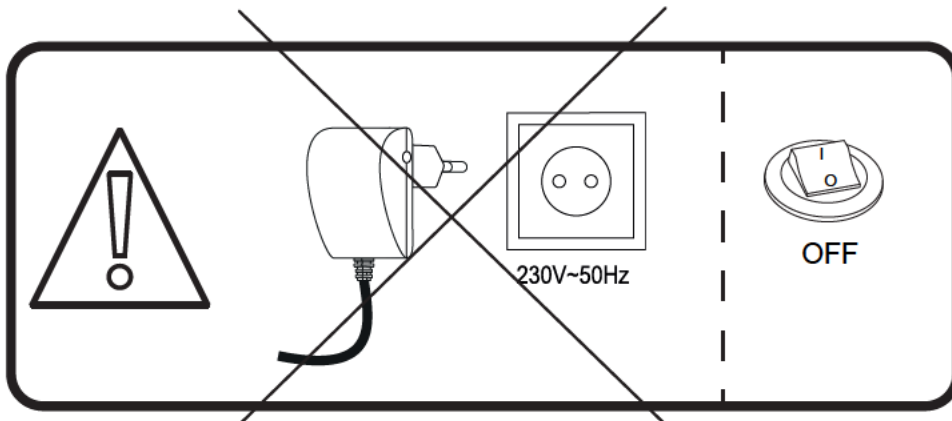
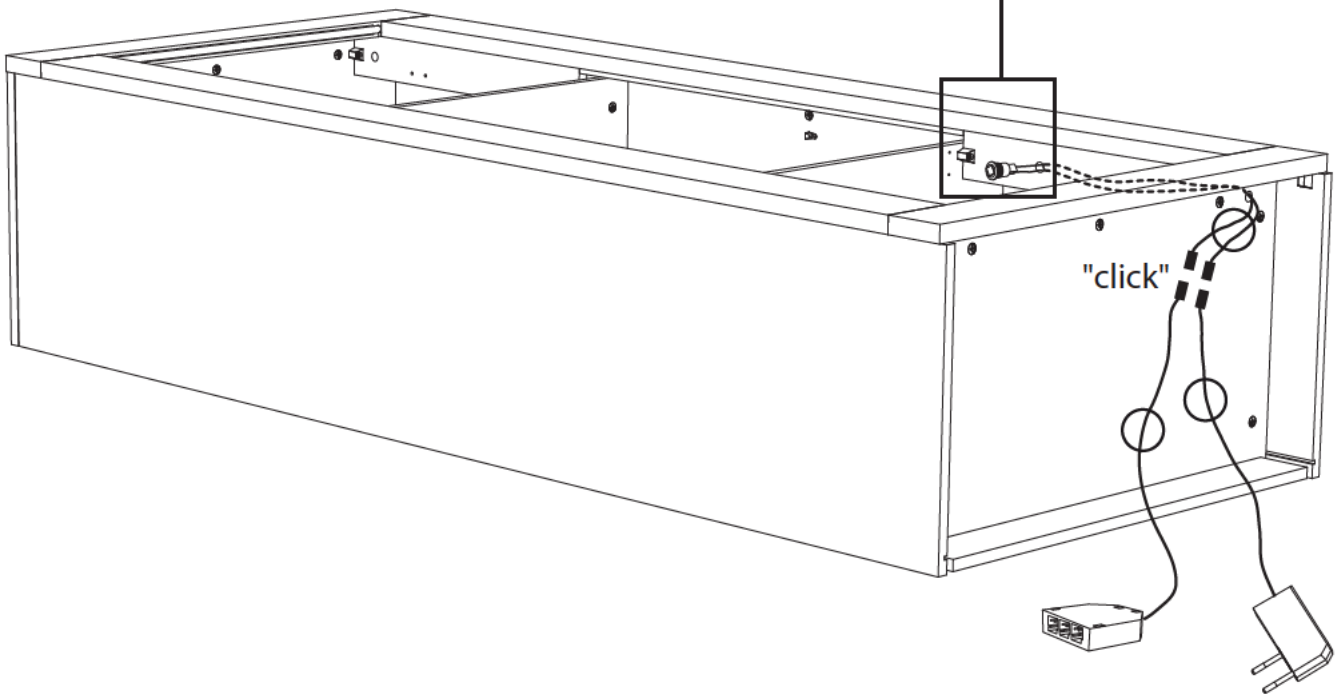
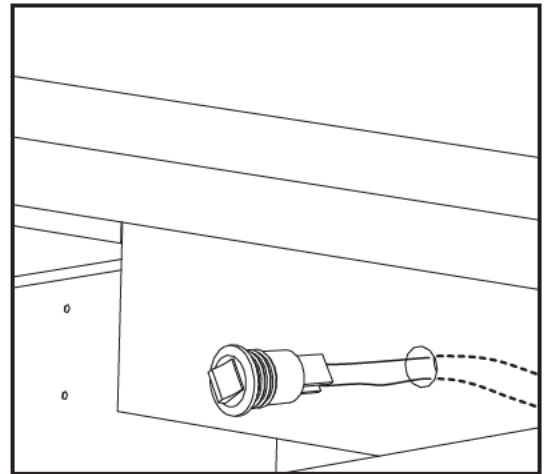
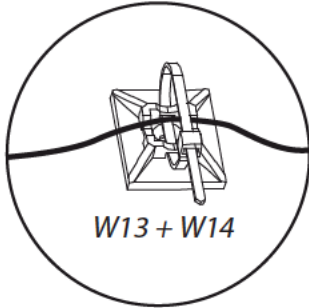

27

L1 - x1
W13 - x2
W14 - x2

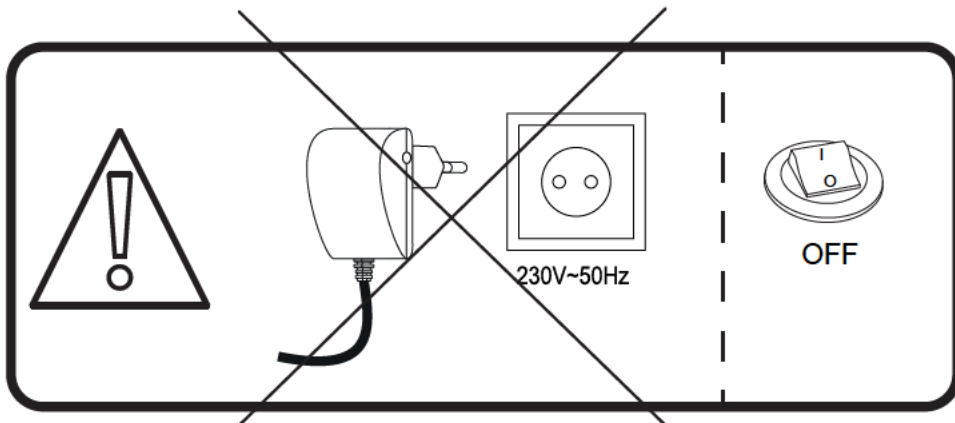
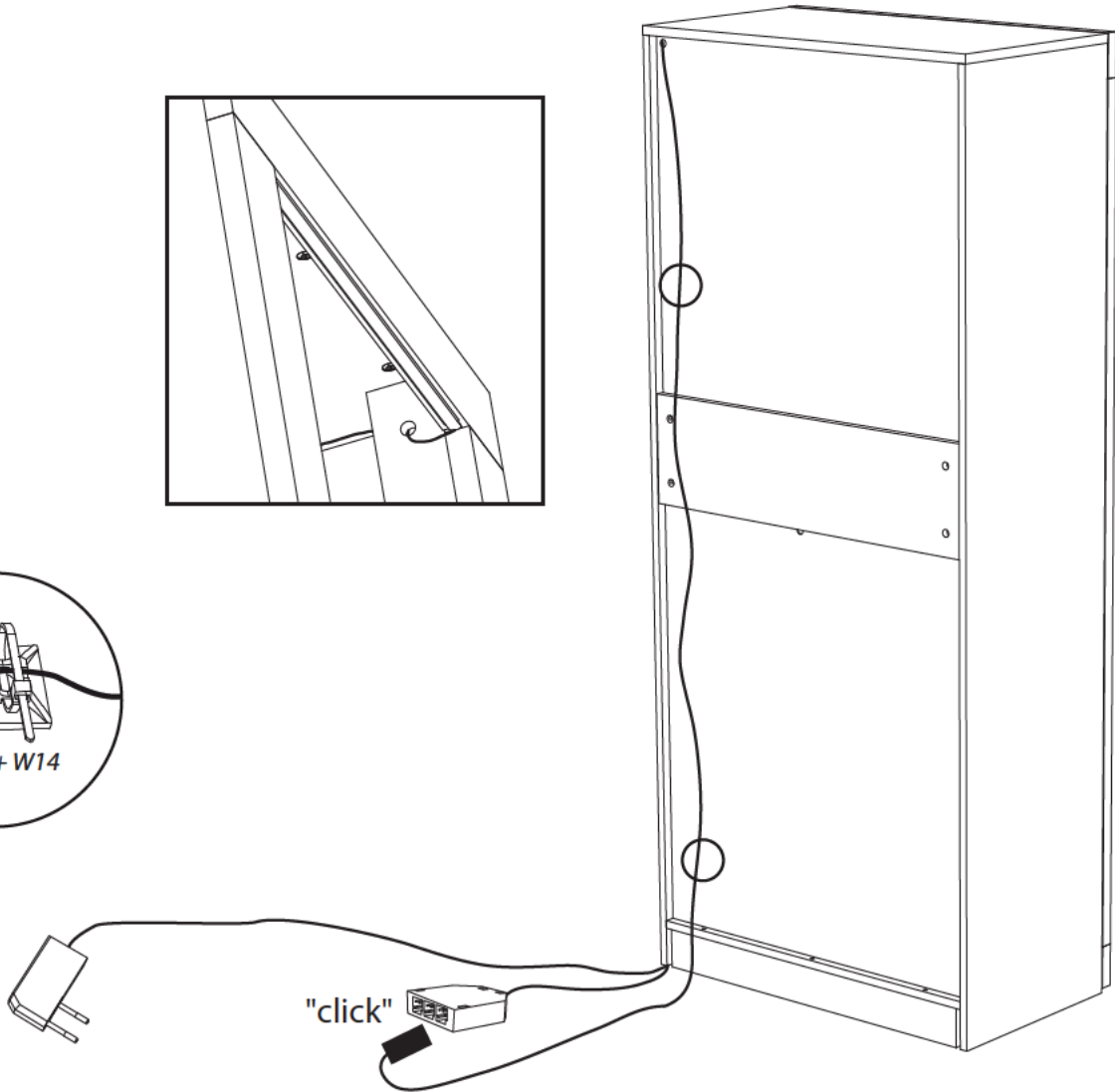
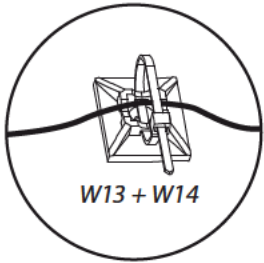
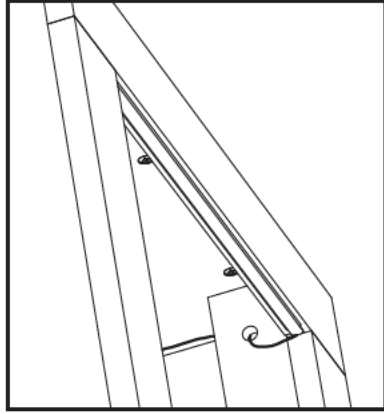

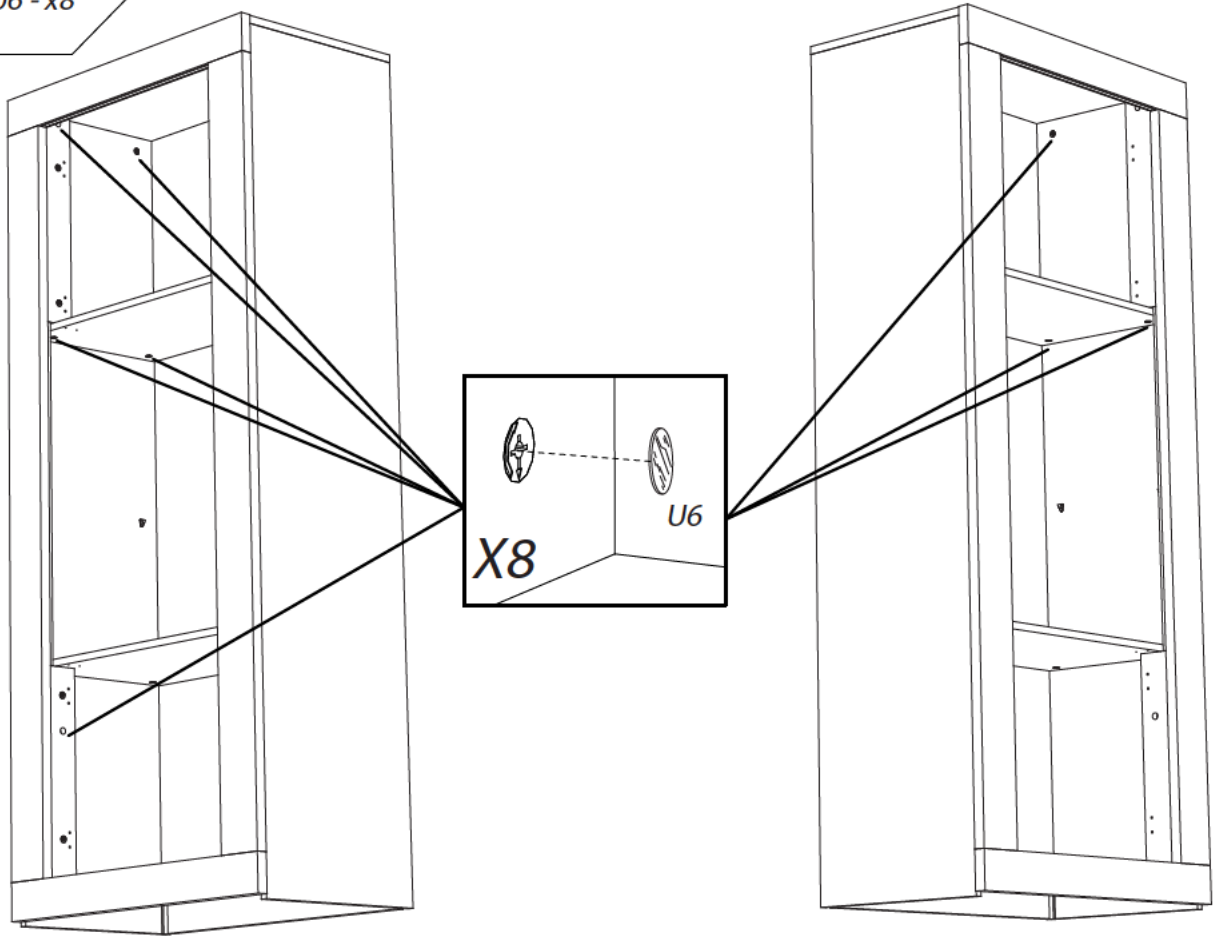

Il existe une grande diversité de types de murs ou cloisons, c'est la raison pour laquelle nous ne pouvons vous fournir le type exact de fixation. Il est nécessaire d'identifier le type de paroi à laquelle vous allez fixer ce produit afin de vous procurer les fixations appropriées. Voici quelques exemples de fixations conseillées pour :

LES MURS PLEINS

CHEVILLE NYLON
"FISCHER"

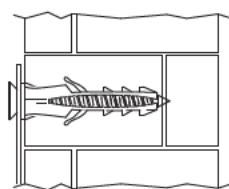
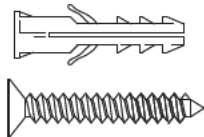

CHEVILLE D'ANCRAGE
METAL

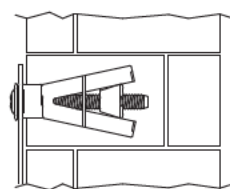
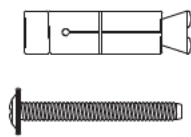

CHEVILLE D'ANCRAGE
A AILETTES EN NYLON

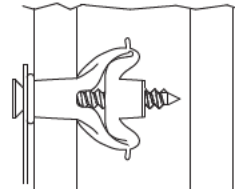
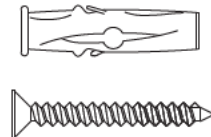

LES CLOISONS CREUSES

CHEVILLE METALLIQUE
A EXPANSION

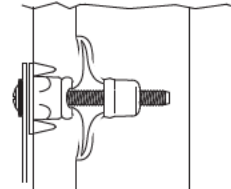
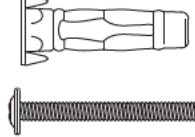

CHEVILLE "MOLLY"

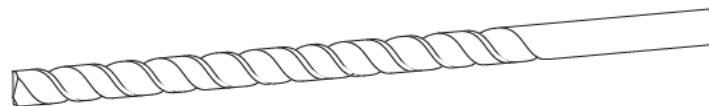
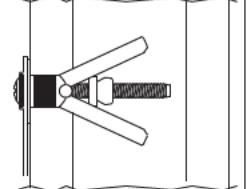
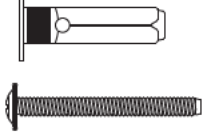

Utiliser une taille de forêt adaptée à la quincaillerie utilisée et au type de mur.

FRANCAIS: Pour votre sécurité il est impératif de fixer votre meuble au mur.

ENGLISH: For your own safety, this furniture must be fastened to the wall imperatively.

DEUTSCH: Zu Ihre Sicherheit, ist es notwendig Ihr Möbel auf dem Wand zu fixieren.

FRANCAIS

IMPORTANT: La vis fournie avec le dispositif anti-bascule est destinée à fixer le dispositif dans le meuble. Pour la fixation au mur, compléter par une vis adaptée au support mural. En cas de doute, contacter un magasin de bricolage.

ENGLISH

IMPORTANT: The screw supplied together with the anti-topple bracket is to be used only for fixing the anti-topple bracket to the furniture. In addition to this, you will need to choose a screw or fitting which is suitable for securing the bracket to the kind of walls you have. If you are unsure about what type of screw to use contact your local hardware store.

DEUTSCH

WICHTIG: Die dem kippschutz beigefügten schrauben sind ausschließlich für die befestigung des kippschutzes am möbelstück vorgesehen. Für die befestigung des kippschutzes an der wand benötigen sie zusätzlich schrauben oder beschläge, die zur beschaffenheit der wand passen. Falls sie nicht sicher sind, welche art von schrauben geeignet sind, wenden sie sich bitte an den fachhandel.

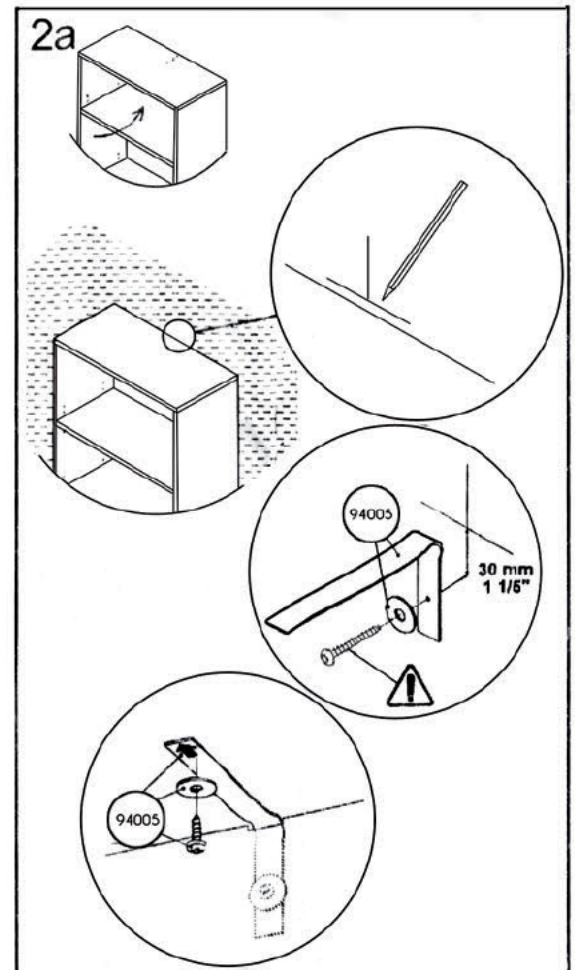
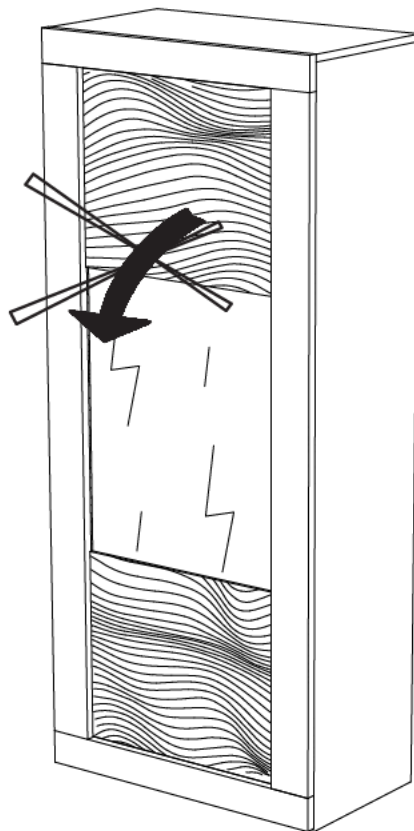

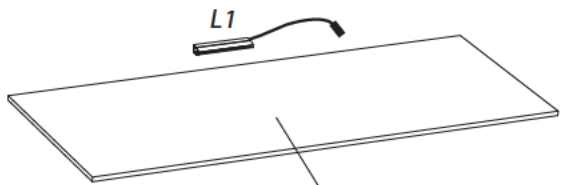

19

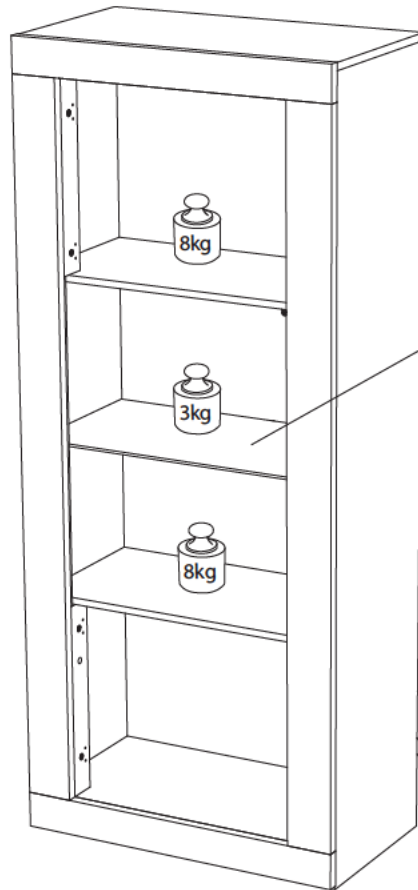
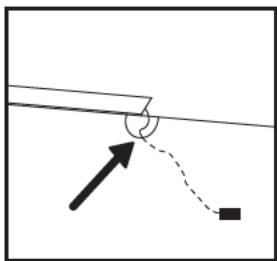

19



"click"

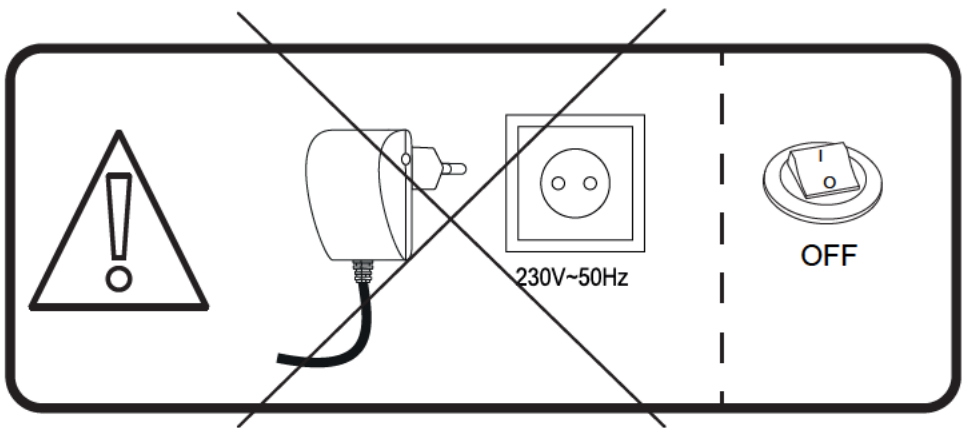

32

D3 - x4
V4 - x8
E4 - x4

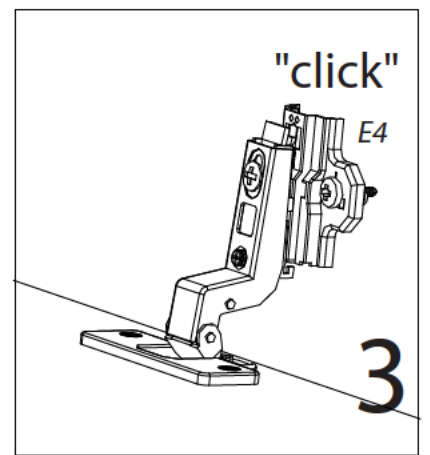
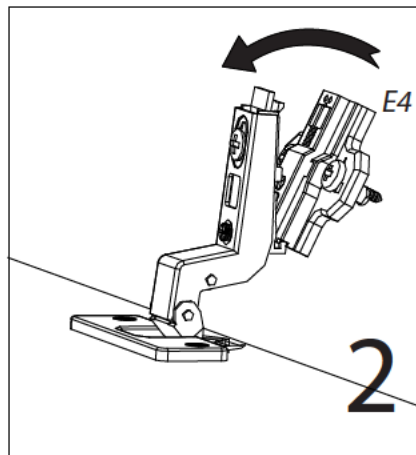
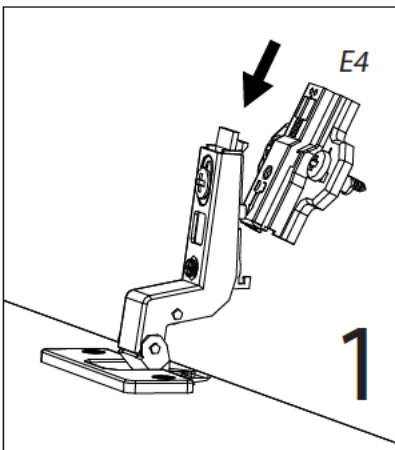
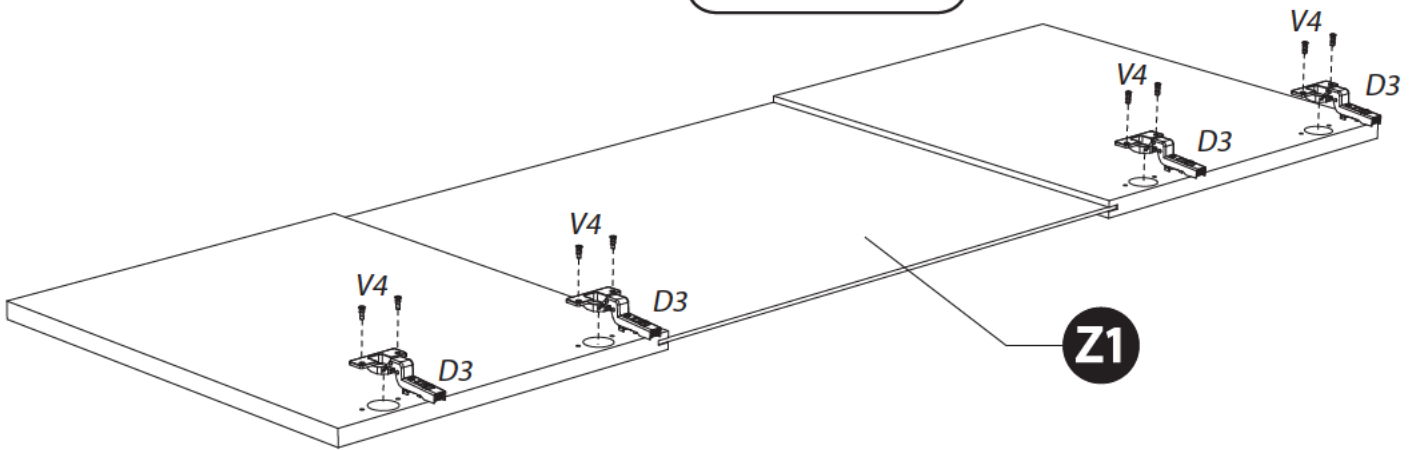

33

N7-x1
V4-x2

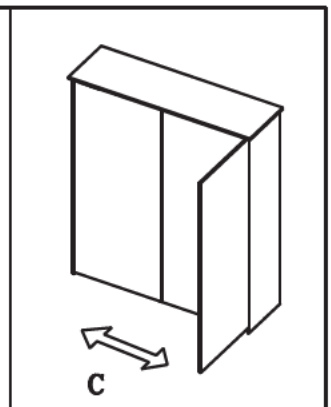
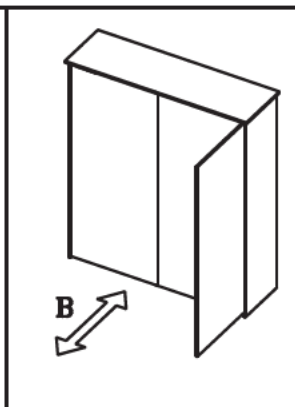
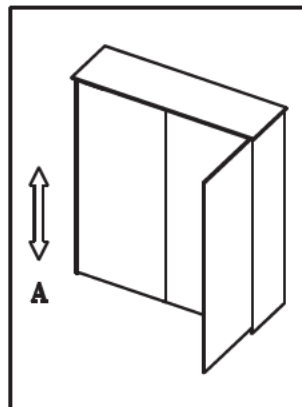
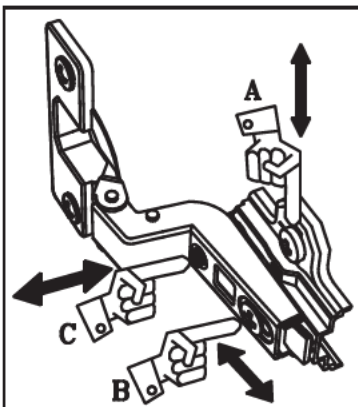
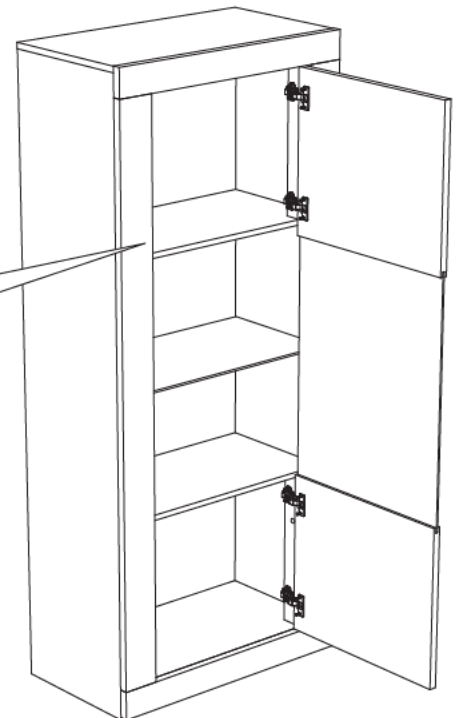
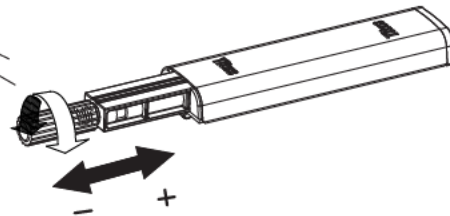
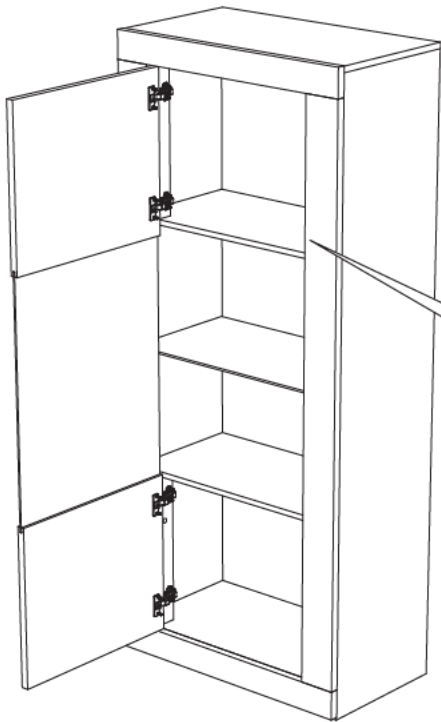
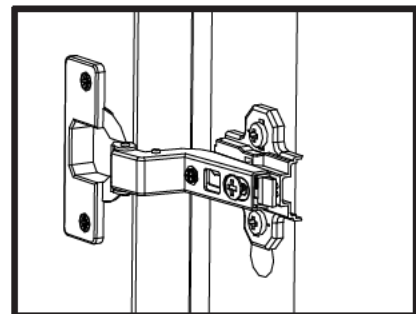
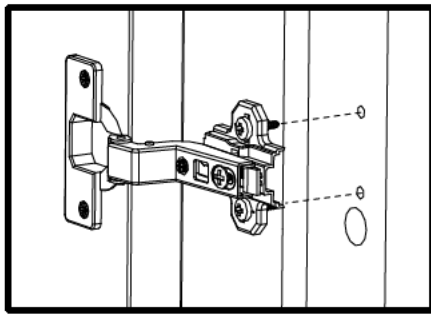
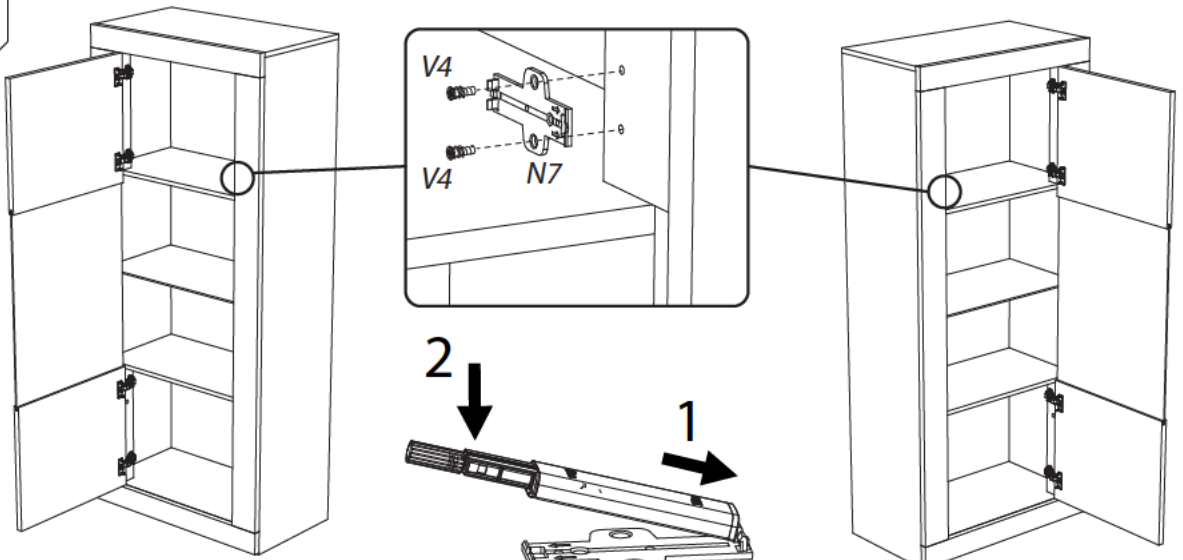

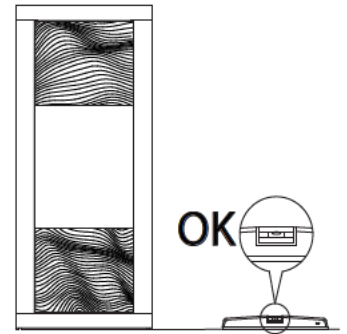
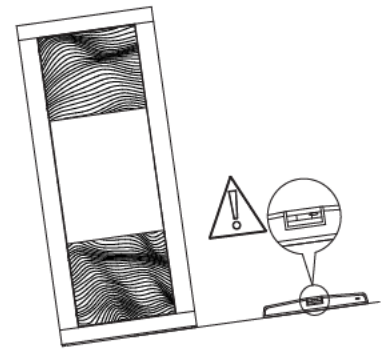
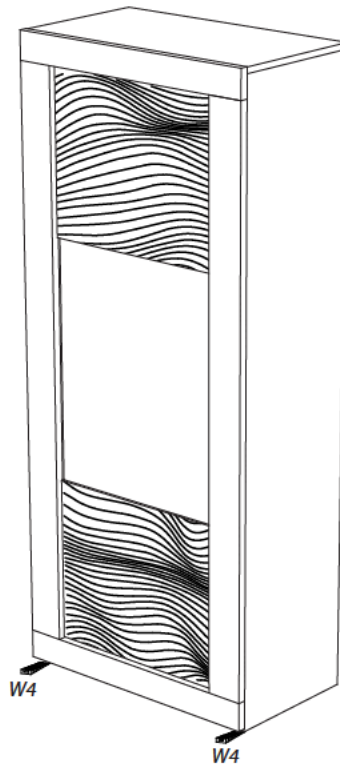
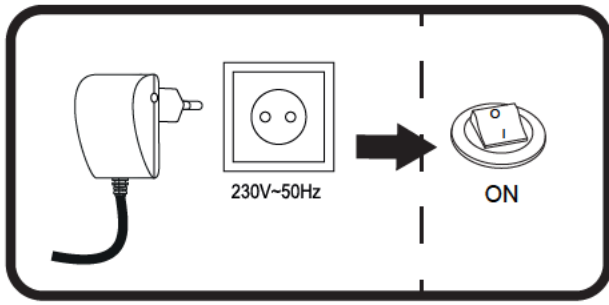

Element vitré 1po composé de panneaux de particules revêtus papier blanc laqués blanc brillant pour les extérieurs.

L.80 cm - H.190 cm - P.45 cm.

A monter soi-même.

Element vitré 1po composé de panneaux de particules revêtus papier blanc laqués blanc brillant pour les extérieurs et les façades decor bois rovere naturelle.

L.80 cm - H.190 cm - P.45 cm.

A monter soi-même.

"Les meubles contenant des panneaux à base de bois (panneaux de particules, panneaux de fibres, contreplaqué...) peuvent émettre des substances polluantes dans l'air intérieur. Il est ainsi recommandé, après l'installation du meuble dans son logement, d'aérer fréquemment la pièce concernée pendant au moins quatre semaines afin de réduire son exposition aux polluants émis par le meuble."

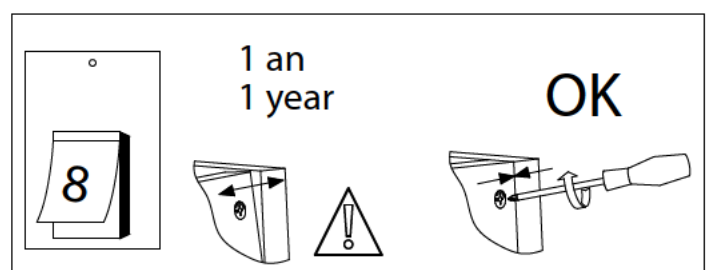
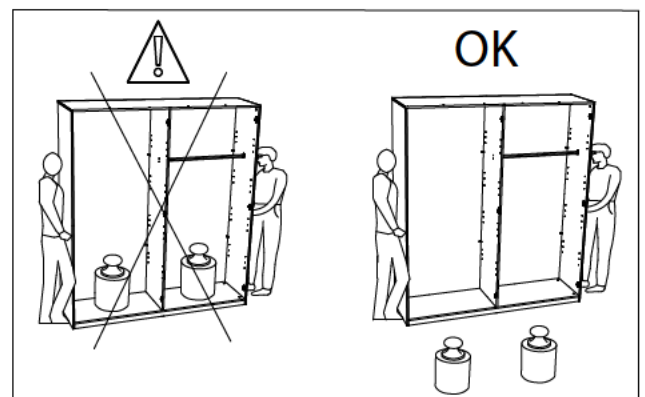
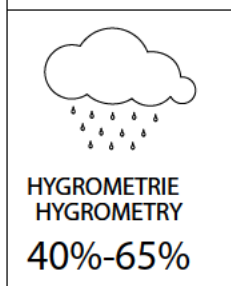
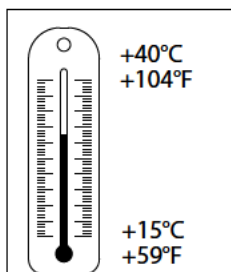

F

L'ÉQUIPEMENT DES PIÈCES ET LE MONTAGE DU MEUBLE DOIVENT ÊTRE RÉALISÉS SUR UN PLAN DE TRAVAIL PROPRE ET PROTÉGÉ.

LORS DE L'UTILISATION, PROTÉGER LE VERNIS DES RAYURES ET DES TACHES.

DÉPOUSSIÉRER LES MEUBLES AVEC UN CHIFFON PROPRE, DOUX ET SEC.

GB

Parts fitting and assembling should be realized on a clean and well protected work top.

For use, please protect the lacquer from scratches and spottings.

Dust each furniture items with a soft, clean, dry cloth. Do not use abrasive cleaners.

D

Das Montage der Teile und der Möbel sollen auf ein sauber und geschütztes Arbeitsplatz gemacht sein.

Schützen Sie das Lack vor Kratzer und Flecke wenn benützung.

Stauben Sie die Möbel mit ein trockenes, sauber, weiches, Staubtuch ab.

E

La instalacion de las piezas y el montaje del mueble han de realizarse sobre un plano limpio y protegido.

Al usar, hay que proteger el barniz de rayas y manchas.

No se olvida desempolvar los muebles con un trapo limpio, suave y seco.

P

O equipamento das peças e a montagem devem ser feitos num plano de trabalho limpo e protegido.

Durante a utilização, proteger o verniz das manhueros e das manchas.

Limpar o po com pano limpo e macio e seco.

I

La disposizione delle parti e il montaggio del mobile devono essere organizzate su un piano di lavoro adatto e sicuro.

Durante l'uso, proteggere le vernici dai graffi e dalle macchie.

Spolverare i mobili con un panno morbido e asciutto

RU

Сборка частей и монтаж мебели должны производиться на освобожденном и подготовленном месте.

В течение эксплуатации стола беречь лак от царапин и пятен.

Стирать пыль с мебели чистой, мягкой и сухой тканью.

CN

零部件装备和家具安装必须在洁净、有保护的操作台上进行

使用桌面时注意表漆，避免产生刮痕和污点

用干净、柔软的干抹布除去家具表面的灰尘

GARANTIE

SI VOUS CONSTATEZ UNE ÉVENTUELLE ANOMALIE, PRÉCISEZ LA NATURE DU DÉFAUT SUR CETTE FICHE ET RETOURNEZ-LA AU MAGASIN QUI VOUS A VENDU LE MEUBLE. CE DOCUMENT NOUS SERA IMMÉDIATEMENT TRANSMIS.

GARANTY

IN THE UNLIKELY EVENT OF THERE BEING A MANUFACTURING OR MATERIAL DEFECT, PLEASE CONTACT THE RETAILER FROM WHOM YOU PURCHASED OUR FURNITURE WITHOUT DELAY. STEPS WILL THEN BE TAKEN TO EFFECT EARLY REMEDICAL ACTION.

GARANTIE

SOLLTEN SIE EVENTUELL EINEN MANGEL FESTSTELLEN SO BITTEN WIR SIE, UNS DIESEN NACHSTEHEND ZU BESCHREIBEN UND DIESES BLATT IHREM LIEFERANTEN ZUZUSENDEN.

GARANTIA

SI USTED OBSERVA ALGUNA EVANTUAL ANOMALIA, EXPLIQUE EL INDOLE DEL DEFECTO Y DEVUELVA LA FICHA A LA TIENDA DONDE HA COMPRADO EL MUEBLE QUE NOS LA HARA SEGUIR.

GARANTIA

SE DETECTAREM UMA EVENTUAL ANOMALIA, DEFINA A NATUREZA DO DEFEITO NESTA FICHA E DEVOLVAM A LOJA QUE LHE VENDEU OS MOVEIS, ESTE DOCUMENTO NOS SERA IMEDIATAMENTE TRANSMITIDO.

GARANZIA

SE RISCONTRATE UN EVANTUALE ANOMALIA, INDICATE LA NATURA DEL DIFETTO SU QUESTA SHEDA TECNICA E REPORTATELA COMPILATA AL PUNTO VENDITA CHE VI HA VENDUTO QUESTO MOBILE. QUESTO DOCUMENTO CI SARA TRANSMESSO IMMEDIATAMENTE.

ГАРАНТИЯ :

ЕСЛИ ВЫ ВДРУГ ОБНАРУЖИЛИ ДЕФЕКТЫ МАТЕРИАЛА ИЛИ ПРОИЗВОДСТВА, ТОЧНО ОПИШИТЕ ДЕФЕКТ НА ЭТОМ ЛИСТЕ И ОБРАТИТЕСЬ В МАГАЗИН, В КОТОРОМ ВЫ КУПИЛИ МЕБЕЛЬ. ЭТОТ ДОКУМЕНТ БУДЕТ НЕМЕДЛЕННО НАМ ПЕРЕДАН И НАМИ РАССМОТРЕН

保证

如果您发现产品存在制造或是材质问题，请尽快联系您的购买商店，以便我们及时向您反馈。