

COFFEE TABLE ASSEMBLY INSTRUCTIONS

A. TOP 1PC

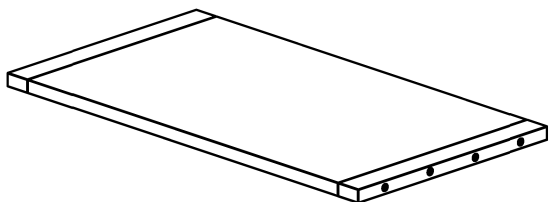

B. LEGS 2PCS

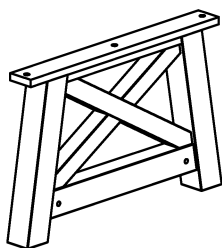



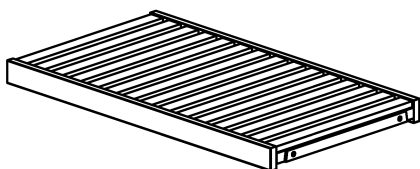

C. SHELF 1PC

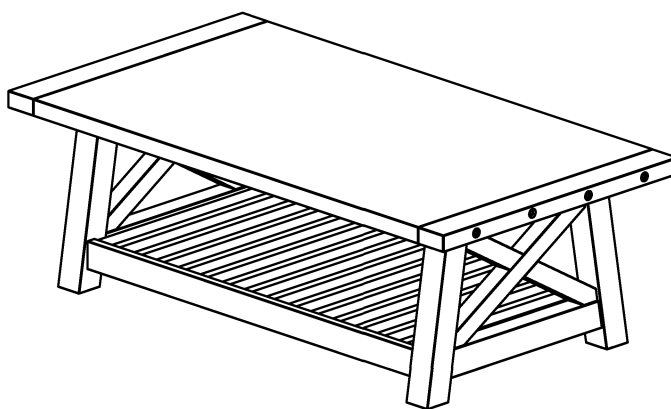

COFFEE TABLE
ASSEMBLED

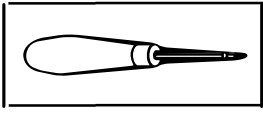

HARDWARE ENCLOSED IN BOX

1	ALLEN BOLT M8 x 40 MM	10 PC	2	WASHER M9/22	10 PCS	3	SPRING WASHER M9/11	10 PCS	4	ALLEN KEY N4	01 PC
											
<p>TOOL REQUIRED</p> <p>PHILLIPS HEAD SCREW DRIVER NOT PROVIDED</p>											

STEP 1:

ON A FLAT, LEVEL AREA LAY DOWN A CLEAN BLANKET OR TOWEL AND PLACE THE TABLE TOP (A) TOPSIDE DOWN. FOLLOWING THE ILLUSTRATION, ATTACH THE TABLE LEG (B) TO THE TOP USING THREE ALLEN BOLTS (1), SPRING WASHERS (3) AND FLAT WASHERS (2). DO NOT TIGHTEN BOLTS COMPLETELY.

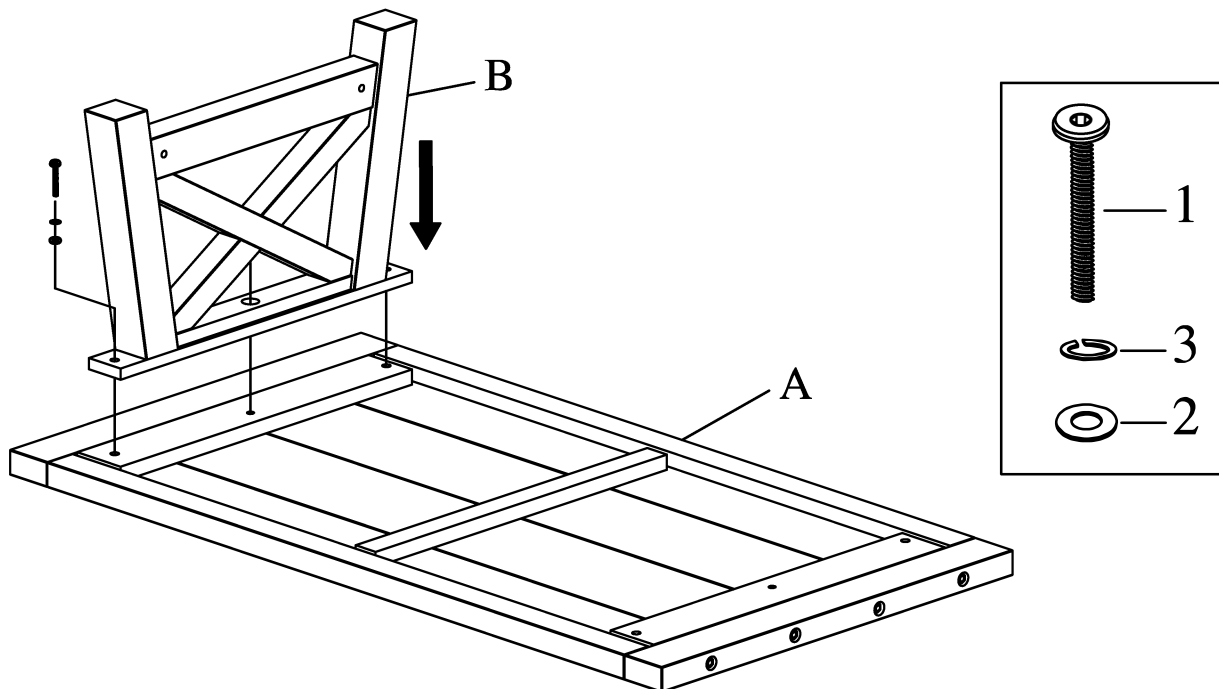

STEP 2:

ATTACH THE OTHER TABLE LEG (B) TO THE TOP USING THREE ALLEN BOLTS (1), SPRING WASHERS (3) AND FLAT WASHERS (2). DO NOT TIGHTEN BOLTS COMPLETELY.

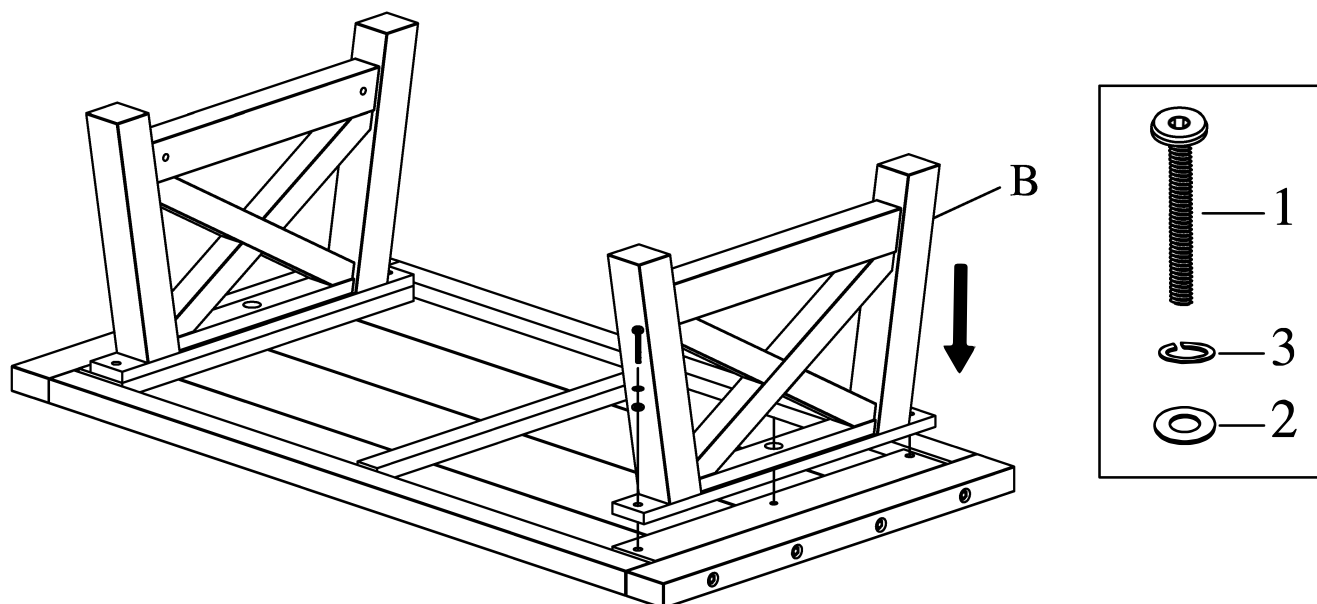

STEP 3:

CONNECT THE TABLE SHELF (C) TO THE LEGS USING FOUR ALLEN BOLTS (1), SPRING WASHERS (3) AND FLAT WASHERS (2); TWO PER SIDE. TIGHTEN THE SHELF BOLTS COMPLETELY USING THE PROVIDED ALLEN KEY (4). AFTER TIGHTENING THE SHELF BOLTS, COMPLETELY TIGHTEN THE SIX BOLTS USED TO ATTACH THE LEGS TO THE TABLE TOP.

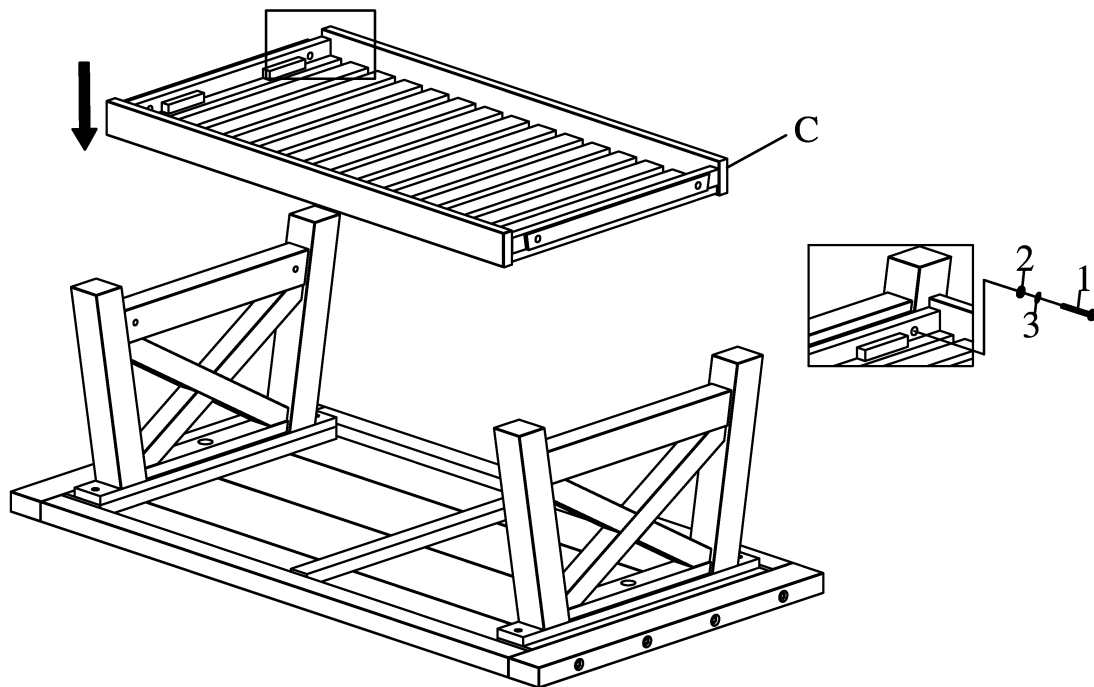

STEP 4:

WITH HELP FROM ANOTHER PERSON, FLIP THE COMPLETED COFFEE TABLE RIGHT SIDE UP BEFORE USING.

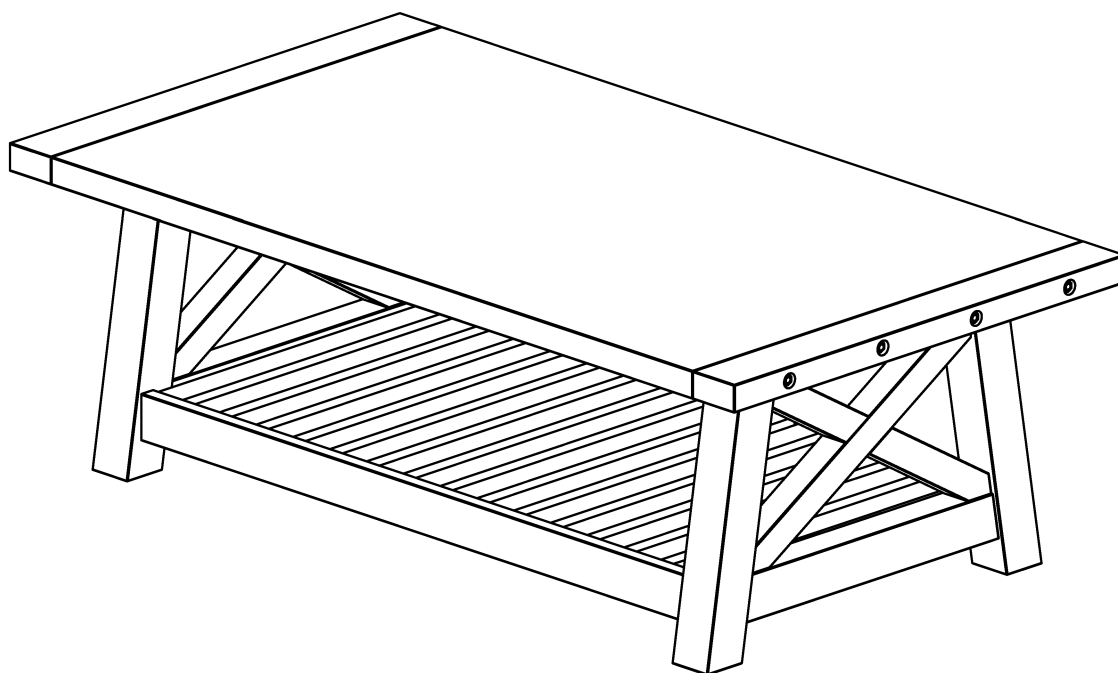

ASSEMBLY COMPLETE.