

## **WARRANTY**

We strive to offer high-quality products, and we also try our best to satisfy each and every customer that orders from us with product or service as needed.

Each customer must provide a record of their order such as the order number, or

item receipt for any items that are out of the warranty period you may also still receive replacement parts by purchasing them with our company if they are available.

**Are you having difficulty  
with assembly? Missing parts?**

**Please contact us : [info@firstopintl.com](mailto:info@firstopintl.com)**

**telephone No.:+1(562)781-3327**

**send email with your order No. to**

**For return, please check the return policy with  
the retailer or market place you bought from.**

**Appreciate your purchasing from us.**

**Pop up your life by our furniture !**

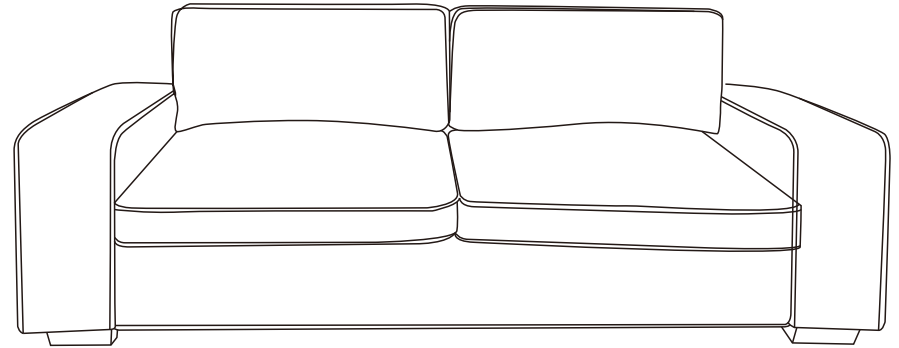
The logo for Wixé, featuring the word "wixé" in a bold, lowercase, sans-serif font. The letter "i" is stylized with a grey dot and a grey vertical bar, and the letter "e" has a grey vertical bar. The rest of the letters are black.

**ITEM NO. :LS0007**

---

### **NOTE:**

This brochure contains IMPORTANT safety info. Please read and keep for future reference.

---

# MAINTAINANCE AND WARNING

- Keep furniture away from heat and fire.
- Keep furniture away from sharp objects.
- Do not clean furniture with harsh cleansers or polish. Do not use detergents, Solvents, abrasives, spray packs or leather cleaner. Use non-color mild soap with warm water clean spills(Mix 1:10 soap to water)
- Do not place furniture under direct sunlight, material will possibly fade over time.
- Do not jump or strike on the furniture.
- Do not write on furniture without a padded barrier to protect the surface.
- Not for commercial use, For residential use only.
- All the pillow stuffing is cut sponge, which is required by the production technology process . We guarantee that the raw materials used are brand new, safe, in accordance with laws and regulations, and have no impact on product quality and safety.



Weight Limitation

**400LBS PER SEAT UNIT**

## PARTS LIST

Ax1

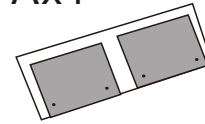

Back frame

Bx1

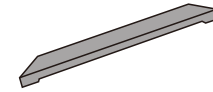

Seat frame

Cx1

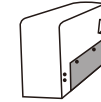

Left armrest

Dx1

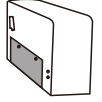

Right armrest

Ex1



Front rail

Fx4



back and front rail bar

Gx2



Side rail bar

Hx2

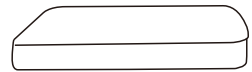

Seat cushion

Ix2



Back cushion  
(Packed in armrests)

Jx4

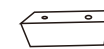

leg

Kx2



Cover of seat cushion

Lx2



Cover of back cushion

## HARDWARE & TOOL LIST

①x12



M6\*40mm Bolt

②x4



M8\*20mm Bolt

③x8



M8\*60mm Bolt

④x20



Washer

⑤x1



Allen Key

## SPARE

①x2



M6\*40mm Bolt

②x1



M8\*20mm Bolt

③x1



M8\*60mm Bolt

④x2



Washer

Be sure to check all packing material fit the packing list. Carefully for small parts, which may have some loose inside the carton during shipment.

# ASSEMBLY INSTRUCTIONS

Remove the Velcro at the bottom of the armrest and remove the back cushion (I) from inside.

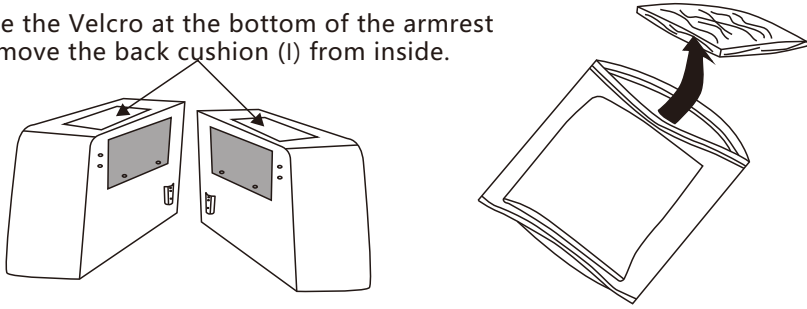

**STEP 1:** Take the back cushions and seat cushions from the vacuum bags, let them expand for a while. (Back cushions are packed in armrests. Take them out from bottom of armrests.)

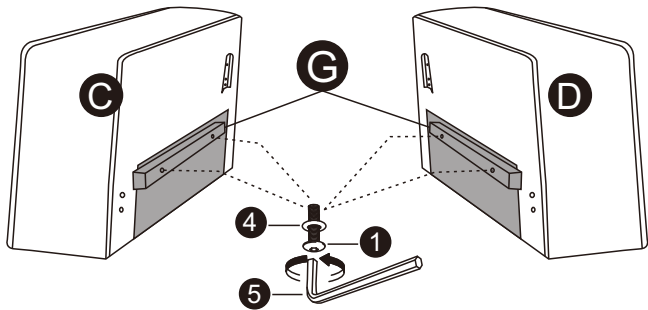

**STEP 2:** Attach the side rail bars (G) to the armrests (C, D) with bolts (1), washer (4) and allen key (5)

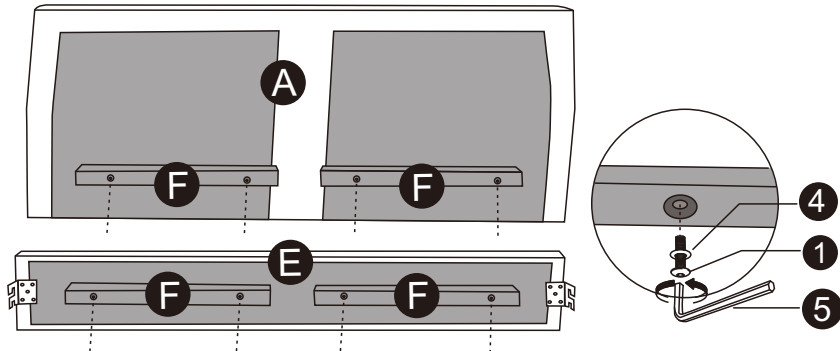

**STEP 3:** Attach the back and front rail bars (F) to the back frame (A) and front rail with bolts (1), washer (4) and allen key (5)

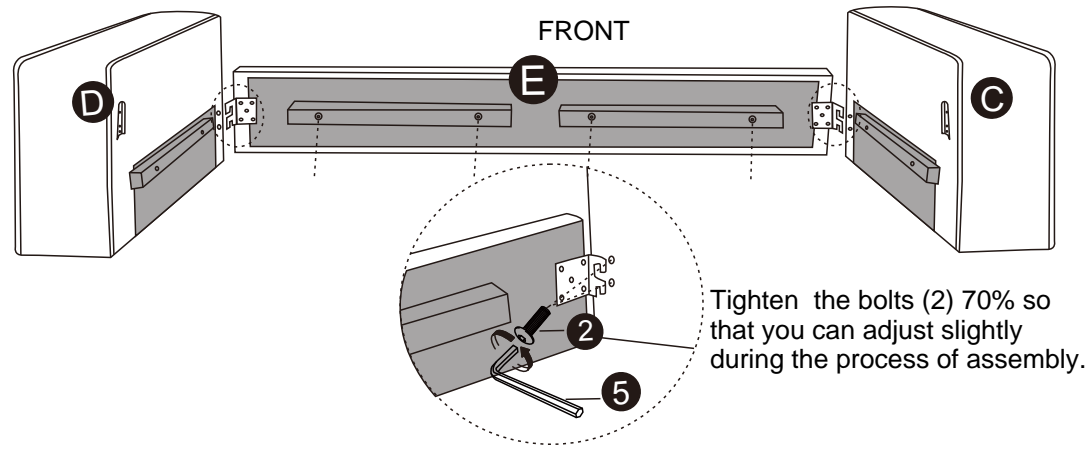

Tighten the bolts (2) 70% so that you can adjust slightly during the process of assembly.

**STEP 4:** Attach front rail (E) to armrests (C, D) with bolts (2) and allen key (5).

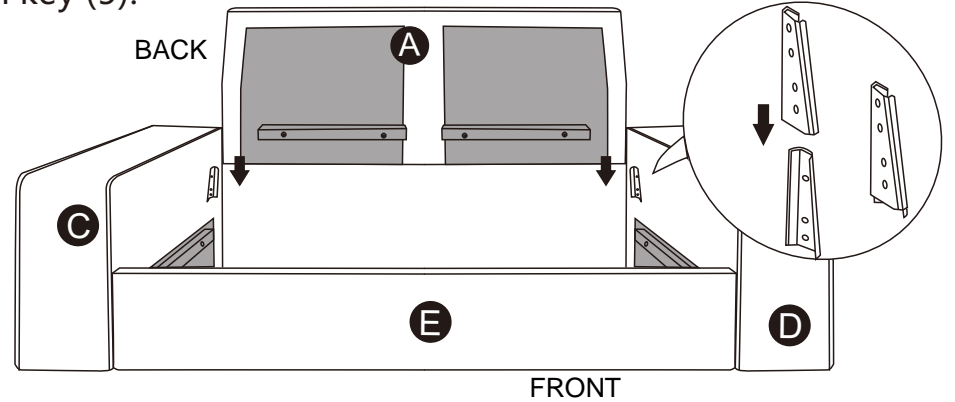

**STEP 5:** Attach backrest to armrest. Insert both connectors at the same time, push hard to connect fully.

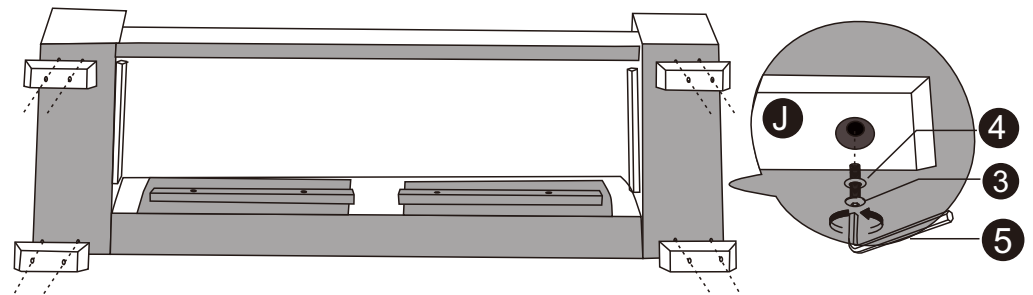

**STEP 6:** Screw legs (J) in to bottom of armrest with bolts (3), washer (4) and allen key (5).

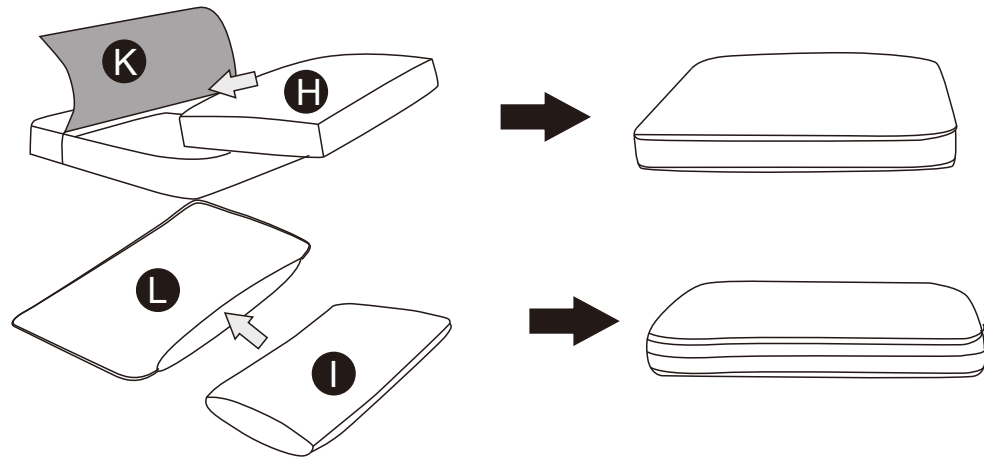
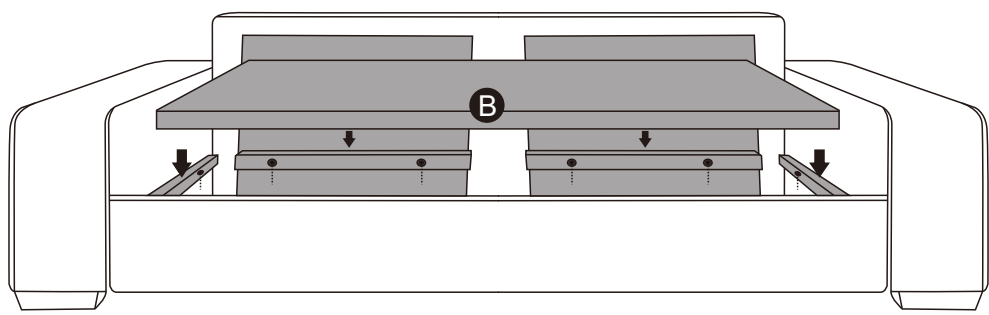

**STEP 7:** Place seat frame(B) on to the rails.

Because of the difference in the fabric of this sofa, the cushion have two situations. One is that the cushion cover is separated from the inner liner, requiring the customer to take out the cloth cover of the cushion on the inner liner. The other is the cushion and cloth cover as a whole, after opening the compression bag, the cushion can be used when it returns to normal. It takes about 24 hours for the compressed seat and cushion to fully return to normal, and you can speed up recovery by tapping the seat and cushion with your hands.

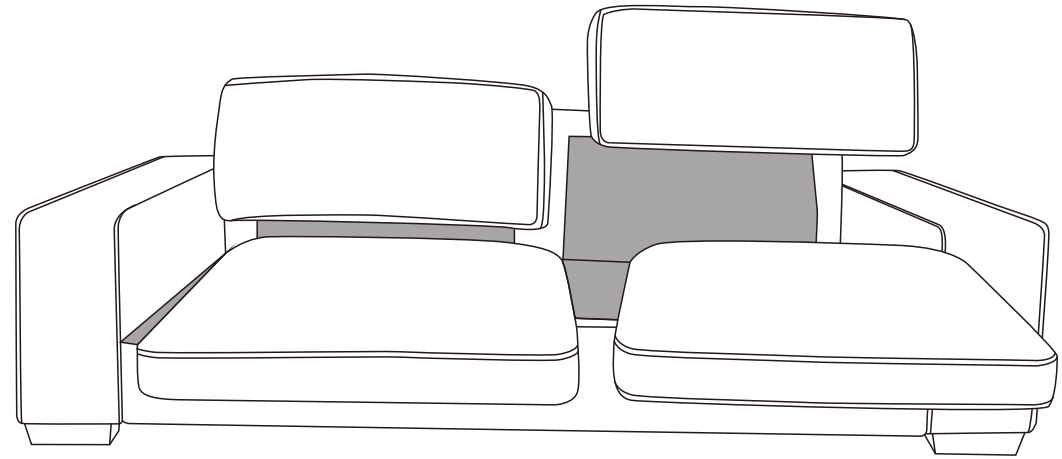

**It will take a while for the cushions to expand. Normally it will take up to around 24 hours to expand to its full size.**

**STEP 8:** Place seat cushions and back cushions on to seat frame and back frame.

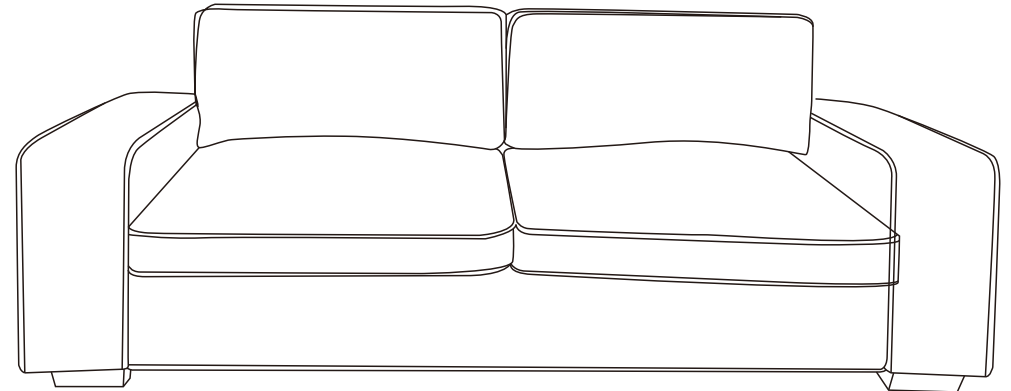

**STEP 9:** Assembly completed.