

ASSEMBLY UNTRUCTION

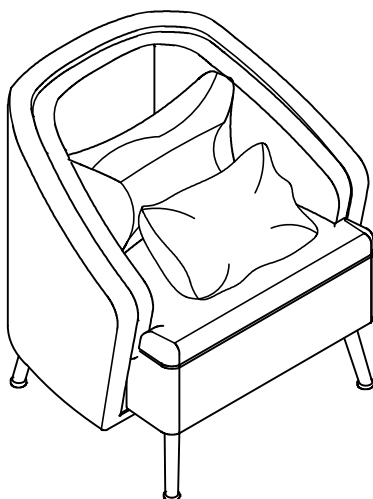

PARTS

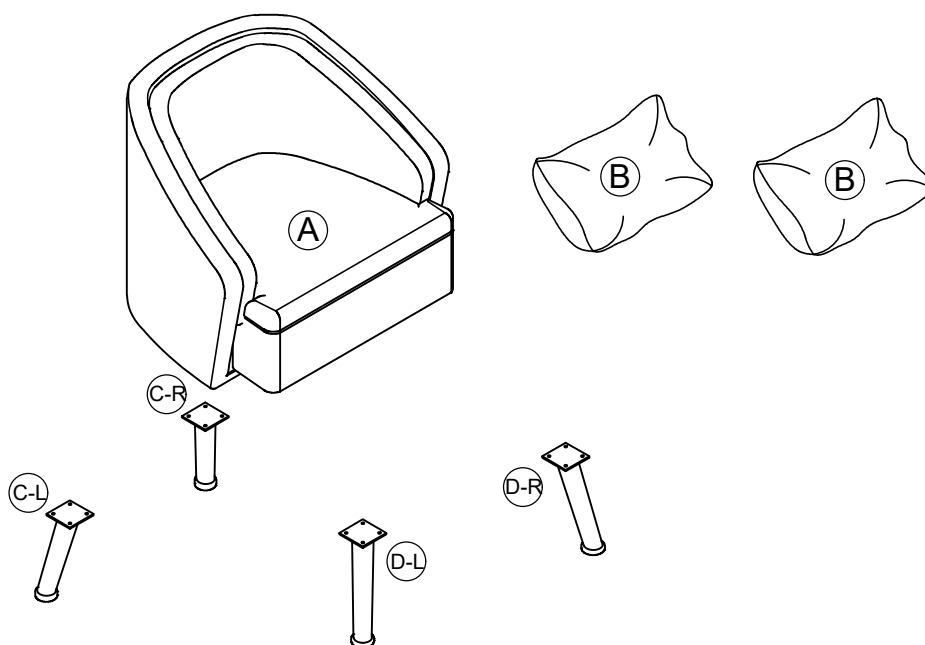

PARTS LIST

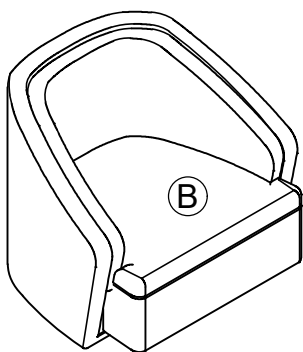

Chair x 1

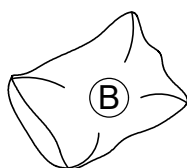

Pillow x 2

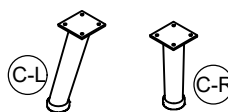

Back Leg x 2

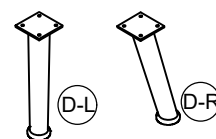

Front Leg x 2

HARDWARE LIST

① x 16

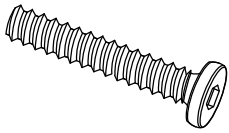

Bolt Ø5/16" x 25mm

② x 16



Spring washer Ø5/16"

③ x 16



Flat washer Ø5/16"

④ x 1

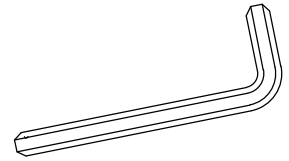

Allenkey

STEP 1:

Place all part on a clean, smooth face.
Take out the part from under the chair.

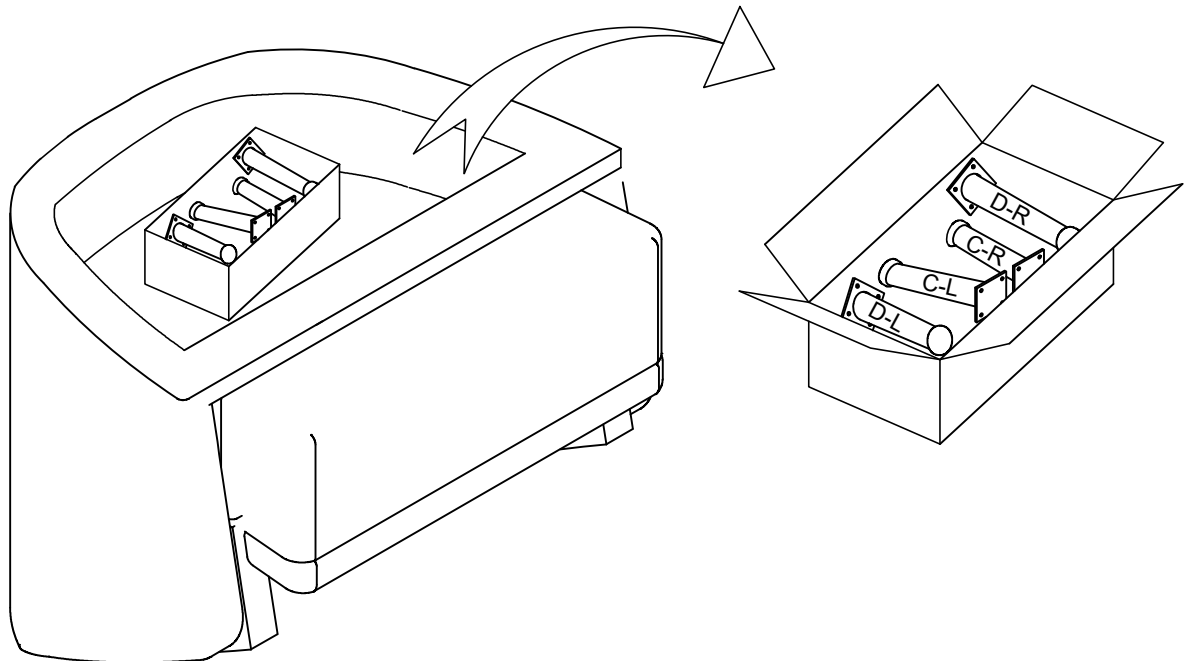

STEP 2:

Place all part on a clean, smooth face.

Attach Front leg D-R&D-L and Back Leg C-R&C-L to A, use Screw bolt (1) ,spring washer(2) flat washer (3) and use the Allenkey (4) to tighten its.

