

# Assembly Instructions

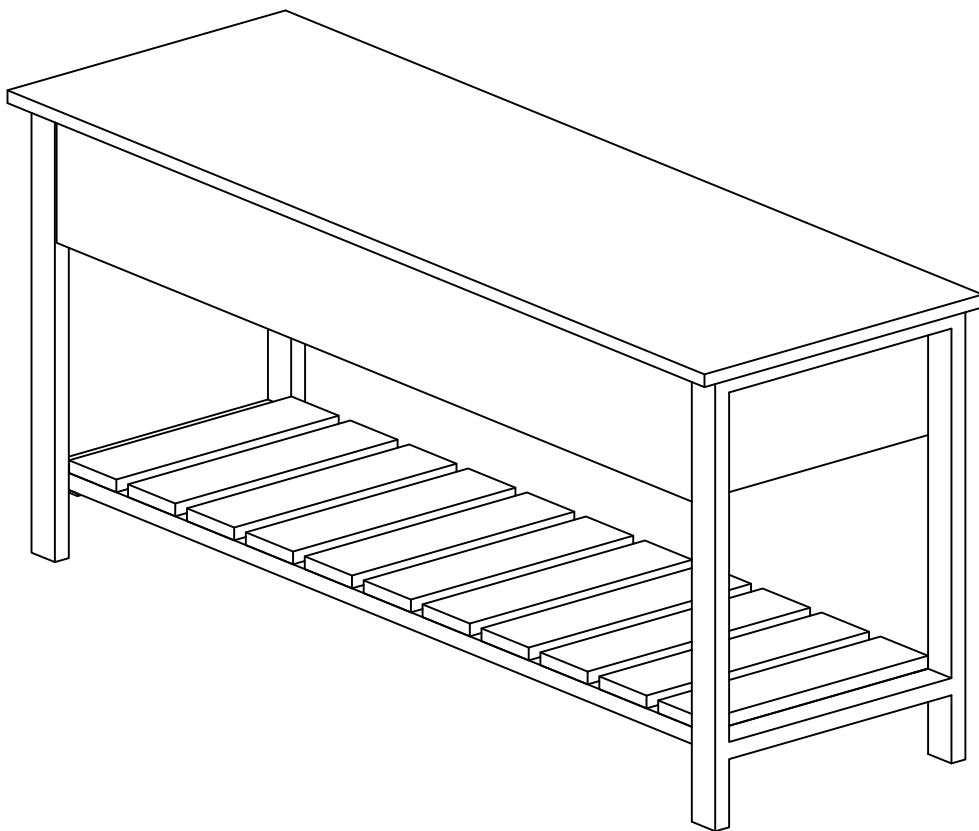

Revised 08/2017

# General Assembly Guidelines

- I. Ensure that all parts and hardware are available before beginning assembly.
- II. Follow each step carefully to ensure the proper assembly of this product.
- III. Two people are recommended for ease in the assembly of this product.
- IV. The three main types of hardware used to assemble this product are : wood dowels , screws and bolts.
- V. The provided glue is to secure wood dowels in place . When first inserting dowels , locate the appropriate hole for the dowel , place a small amount of glue in the hole and insert the dowel . Wipe away excess glue immediately.

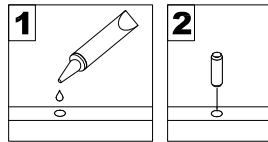

In future assembly steps when dowels are necessary to attach assembly parts together , place a small amount of glue on the end of the dowel before attaching parts together . Wipe away excess glue immediately.

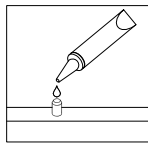

- VI. A Phillips head screwdriver is required for the assembly of this product .

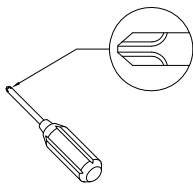



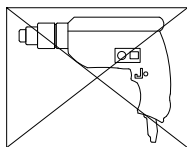



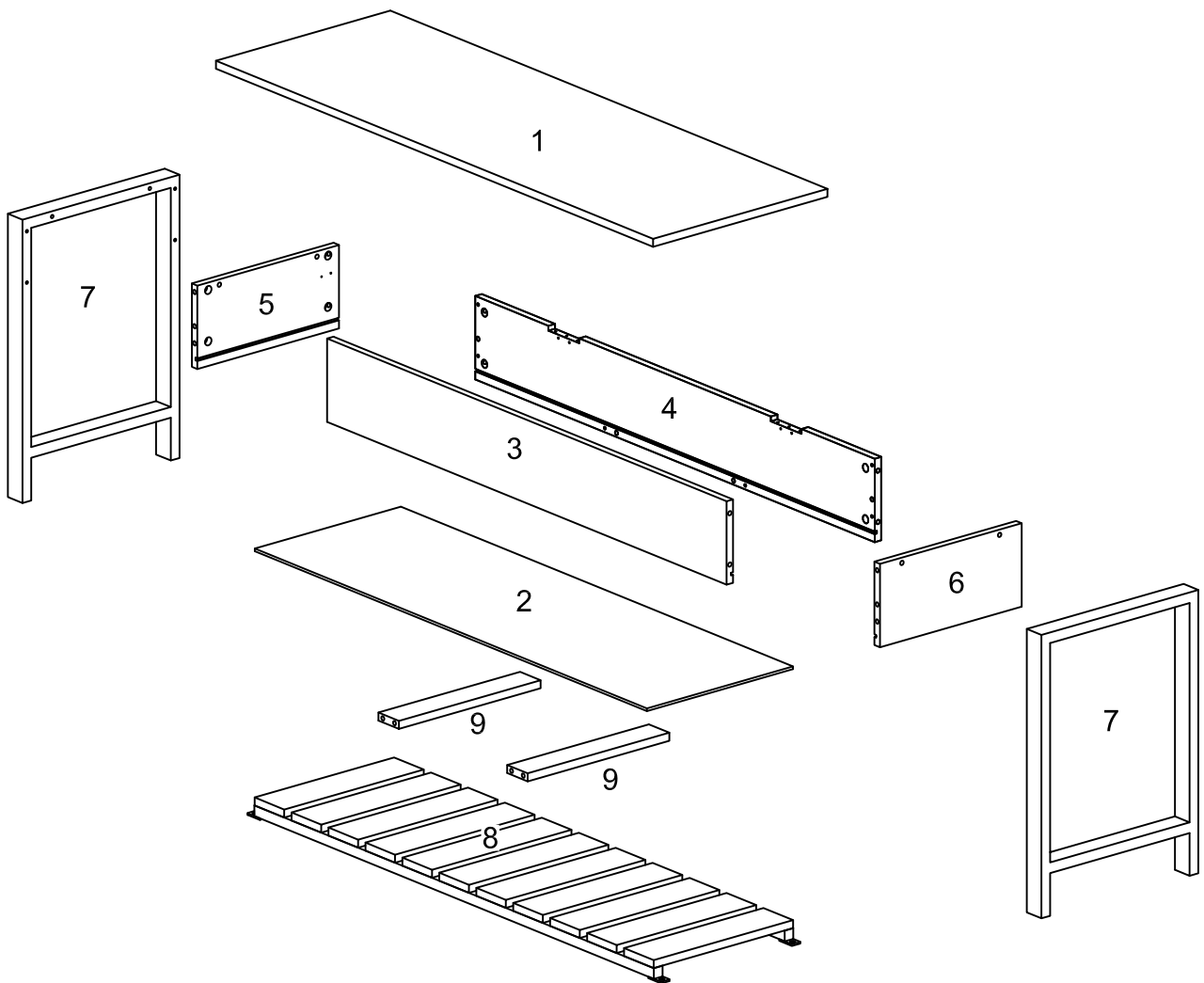



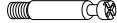

- VII. Power tools should not be used to assemble this product .

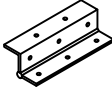

# Parts List

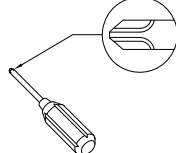

# Hardware List

A		Ø8x30mm	Wooden dowel	8 pcs
B		Ø6x32mm	Cam bolt	8 pcs
C		Ø6x35mm	Cam bolt	12 pcs
D		Ø15x11mm	Cam lock	20 pcs
E		M6*25	Bolt	4 pcs
F		M6*12	Bolt	4 pcs
G		M4*15	Screw	24 pcs
H			Hinge	2 pcs
J		M30	Sticker	20 pcs
K			Cotton pad	2 pcs
L			Right hinge	1 pc
M			Left hinge	1 pc
N		M4	Wrench	1 pc
P	 		Glue tube Philips head screwdriver required for assembly (not included)	1 pc

*The hardware quantities listed above are required for proper assembly.  
Some extra hardware may also have been included.*

# Step 1

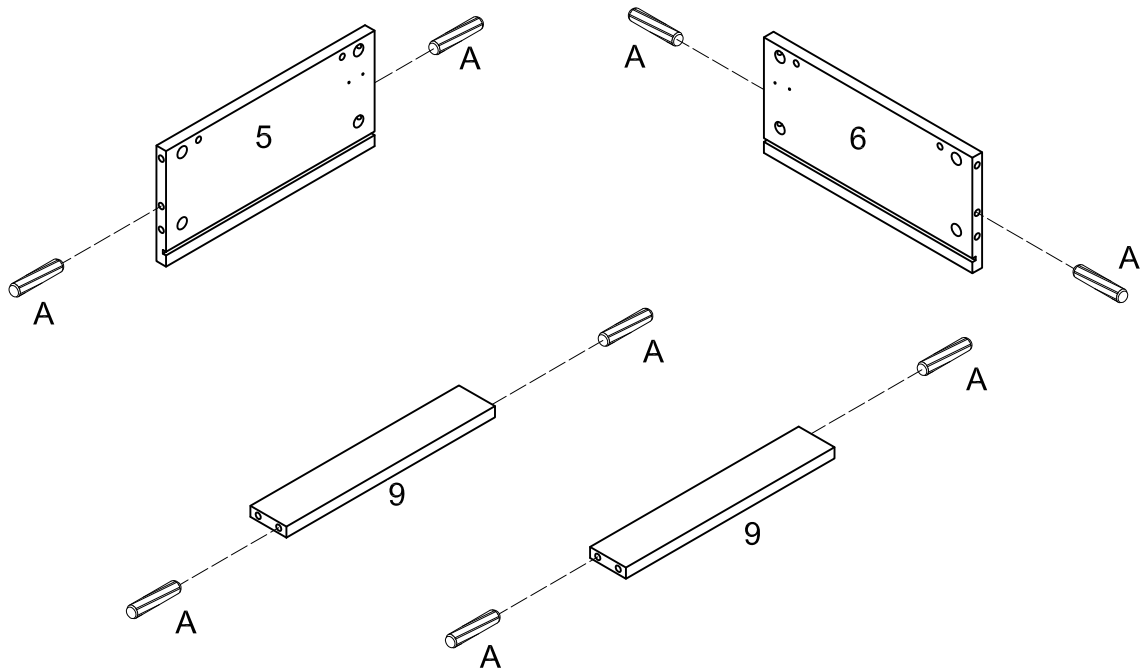

Insert wooden dowel (A) into side panel (5,6) and parts (9).

# Step 2

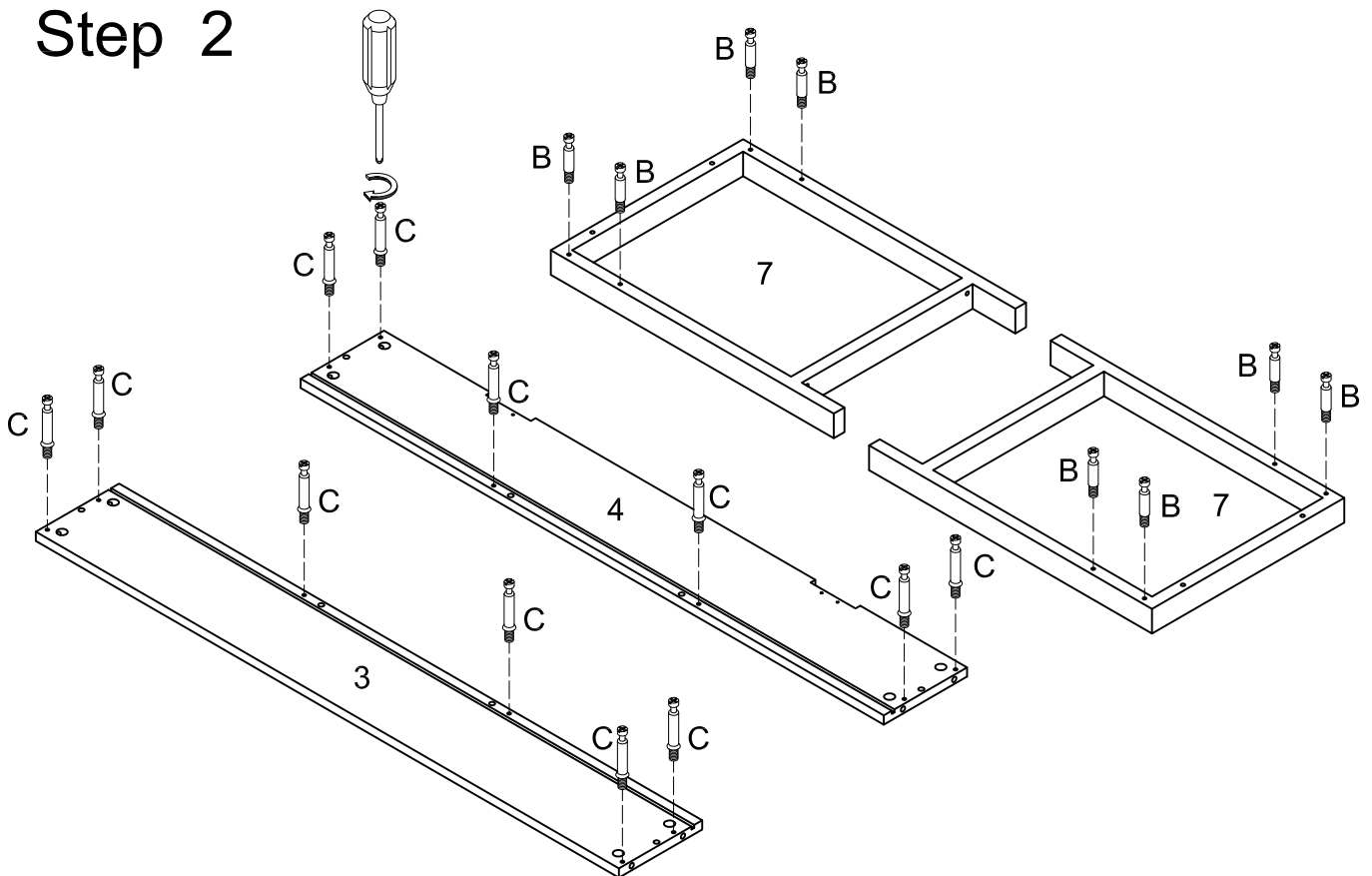

Secure cam bolt (C) to panel (3,4). Secure cam bolt (B) to side frame (7).

# Step 3

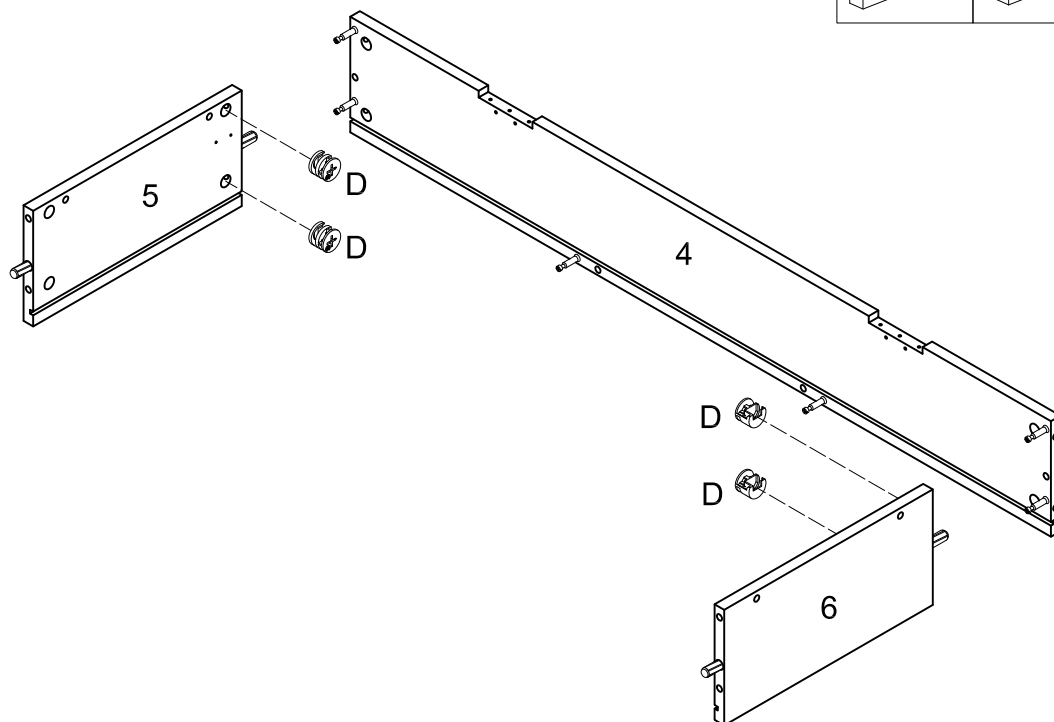
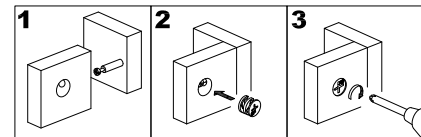

Insert side panel (5,6) to panel (4), then insert and secure cam lock (D) to side panel (5,6) to lock it.

# Step 4

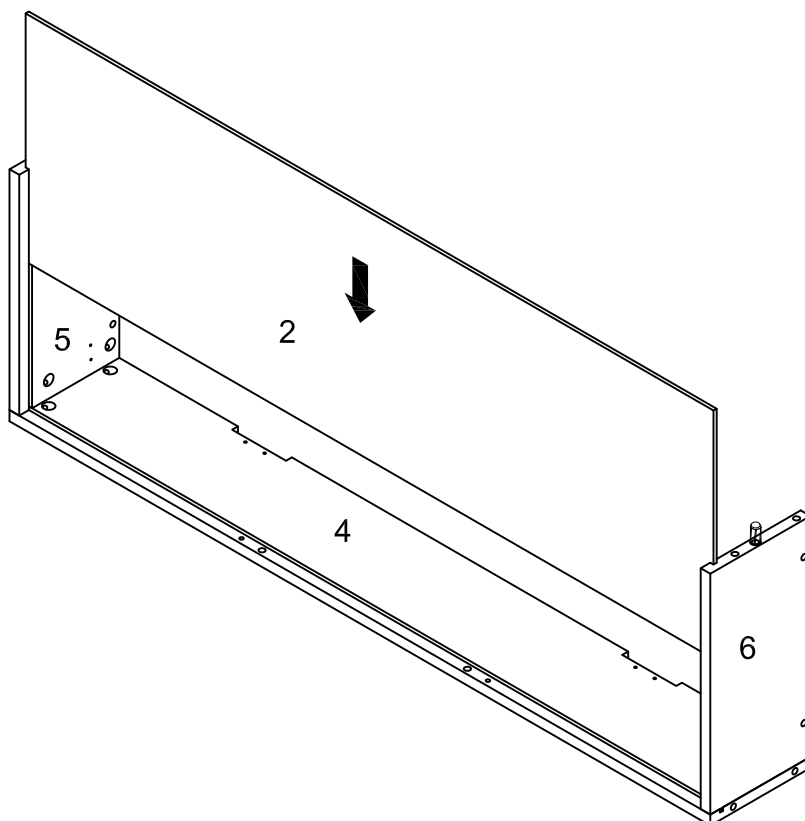

Insert bottom panel (2) through side panel (5,6).

# Step 5

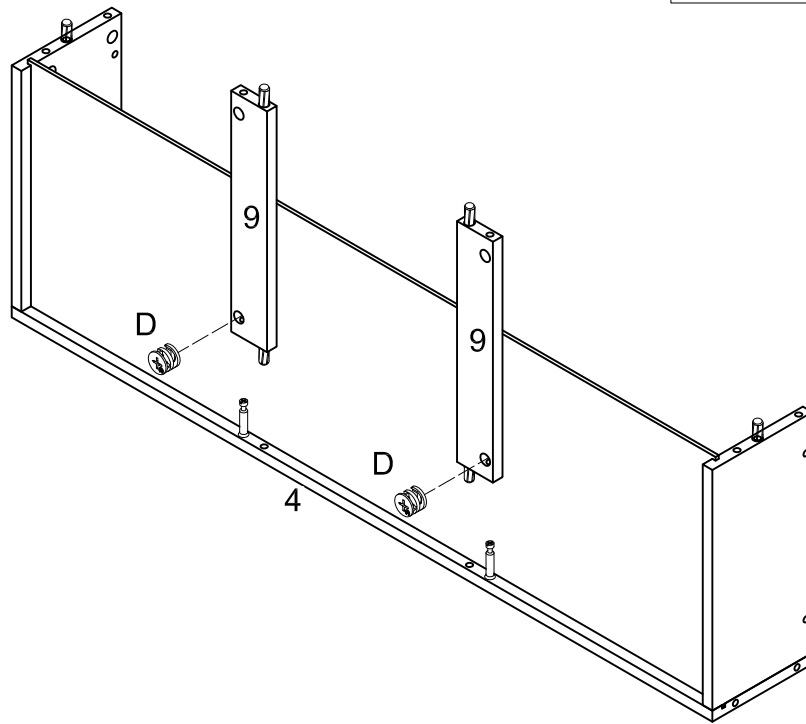
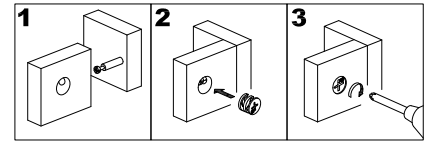

Insert parts (9) into panel (4), then insert and secure cam lock (D) to parts (9) to lock it.

# Step 6

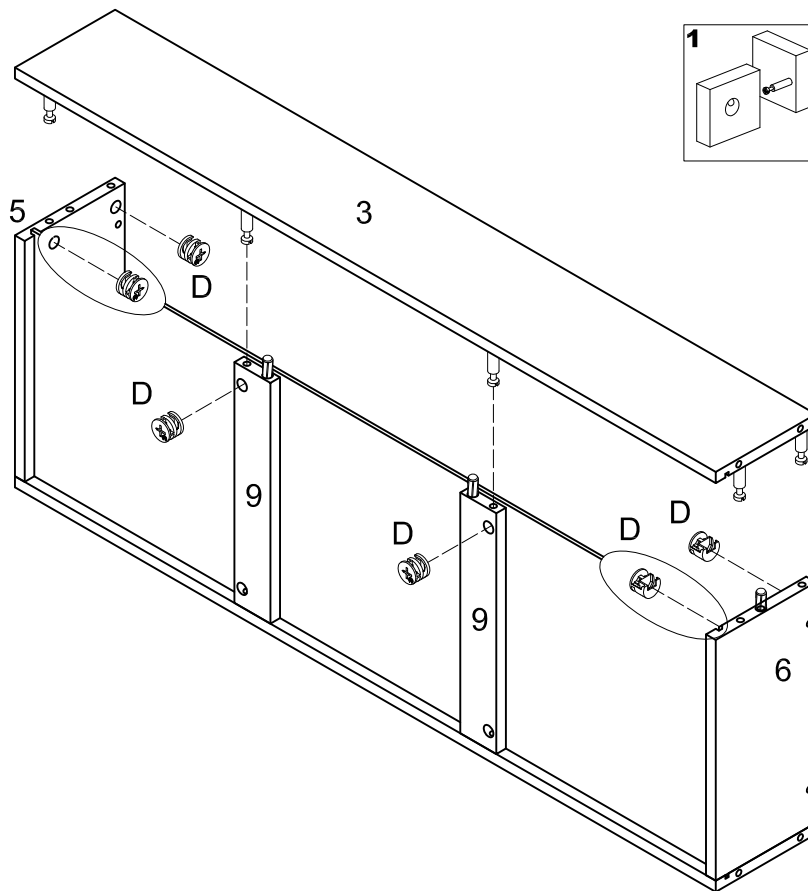
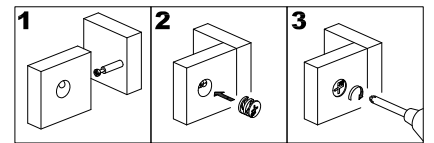

Insert panel (3) into side panel (5,6), then insert and secure cam lock (D) to parts (9) and side panel (5,6) to lock it.

## Step 7

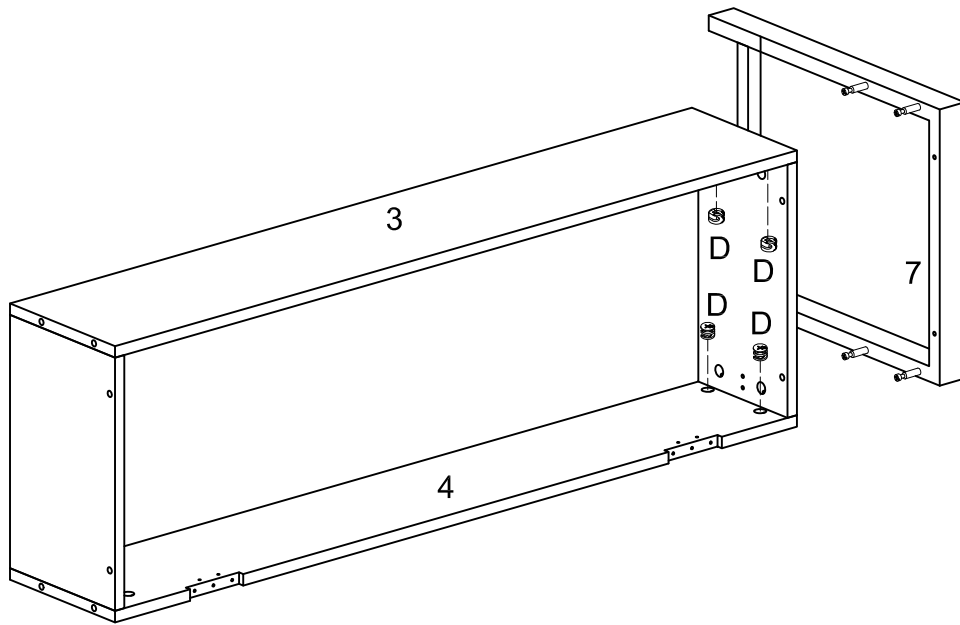
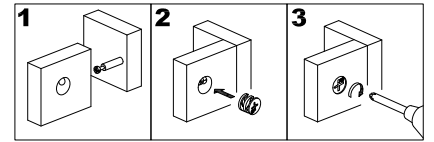

Insert side frame (7) into panel (3,4), then insert and secure cam lock (D) to panel (3,4) to lock it.

## Step 8

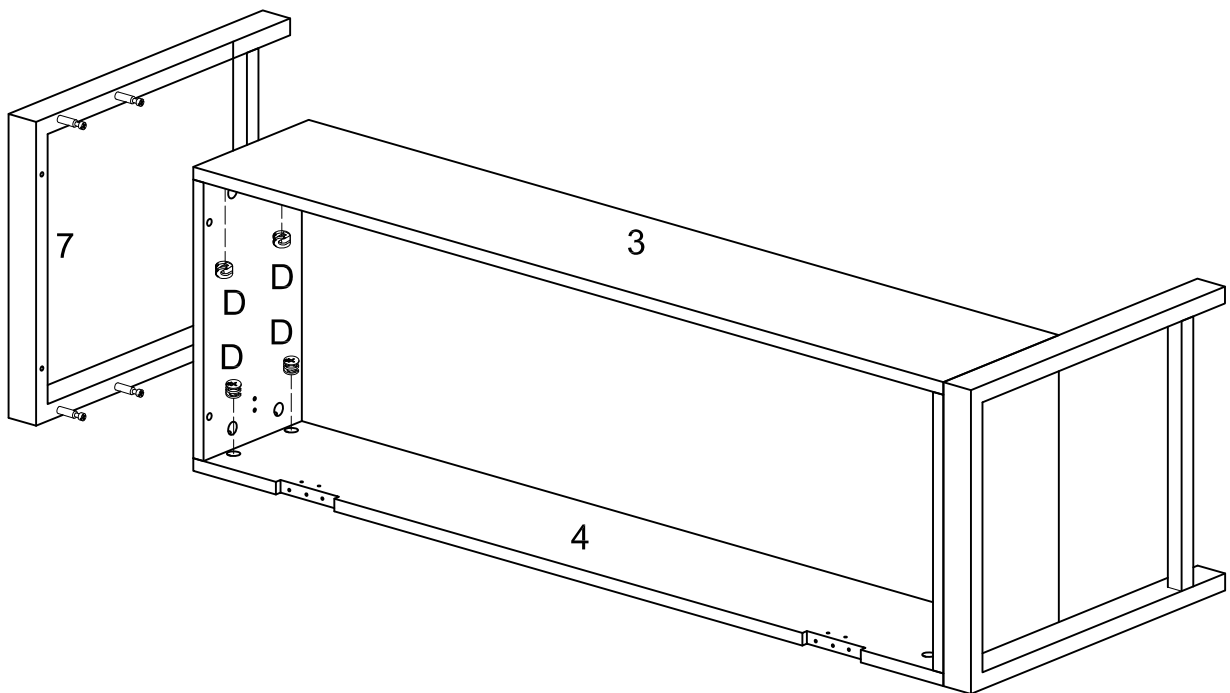
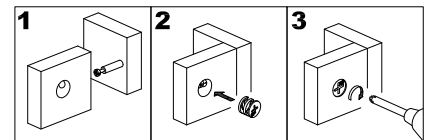

Insert side frame (7) into panel (3,4), then insert and secure cam lock (D) to panel (3,4) to lock it.

## Step 9

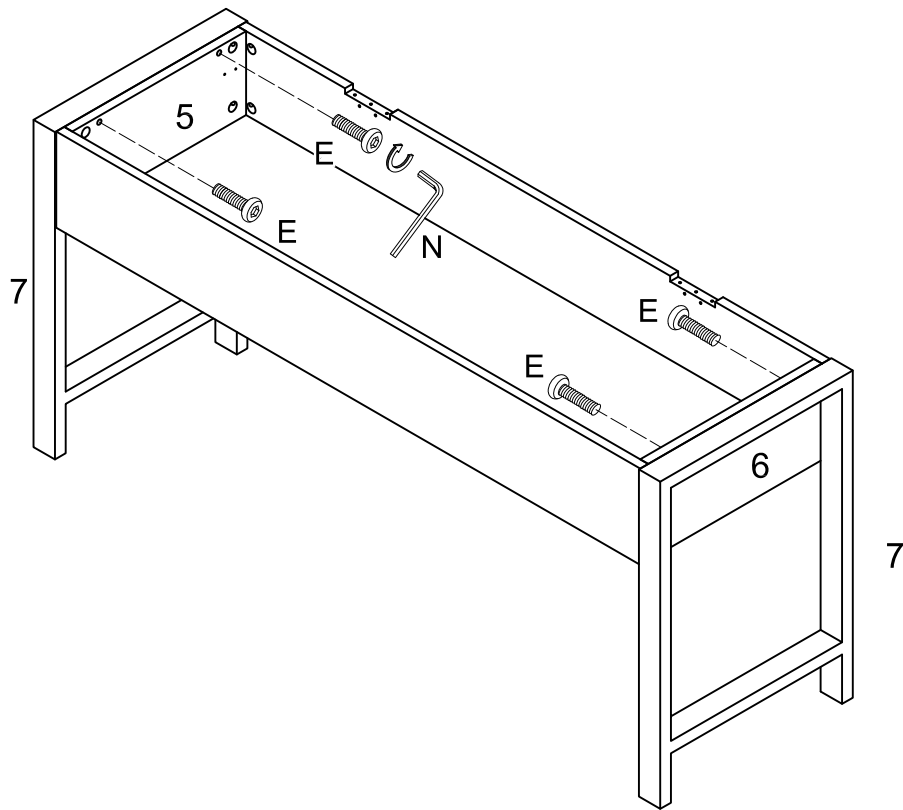

Use wrench (N) to secure side panel (5,6) to side frame (7) with bolt (E).

## Step 10

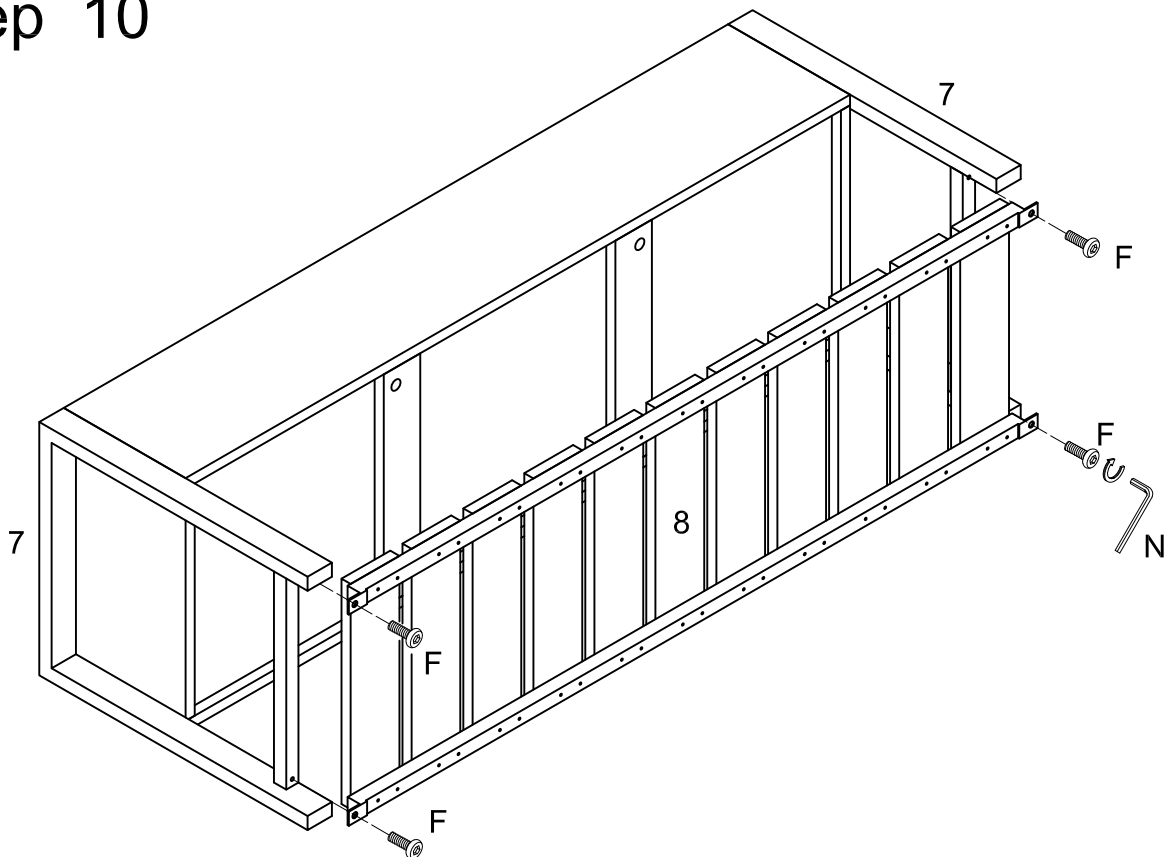

# Step 11

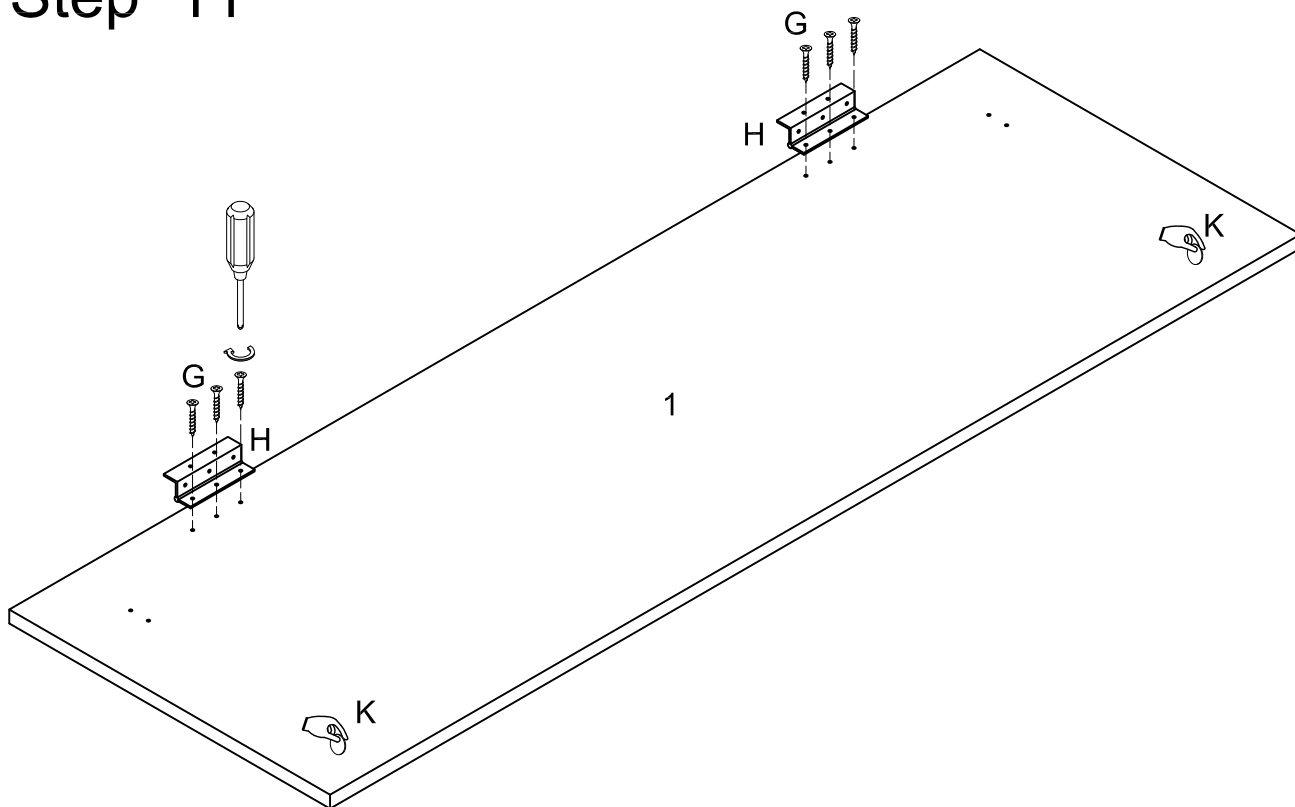

Secure hinge (H) to top panel (1) with screw (G). Place cotton pad (K) as per diagram.

# Step 12

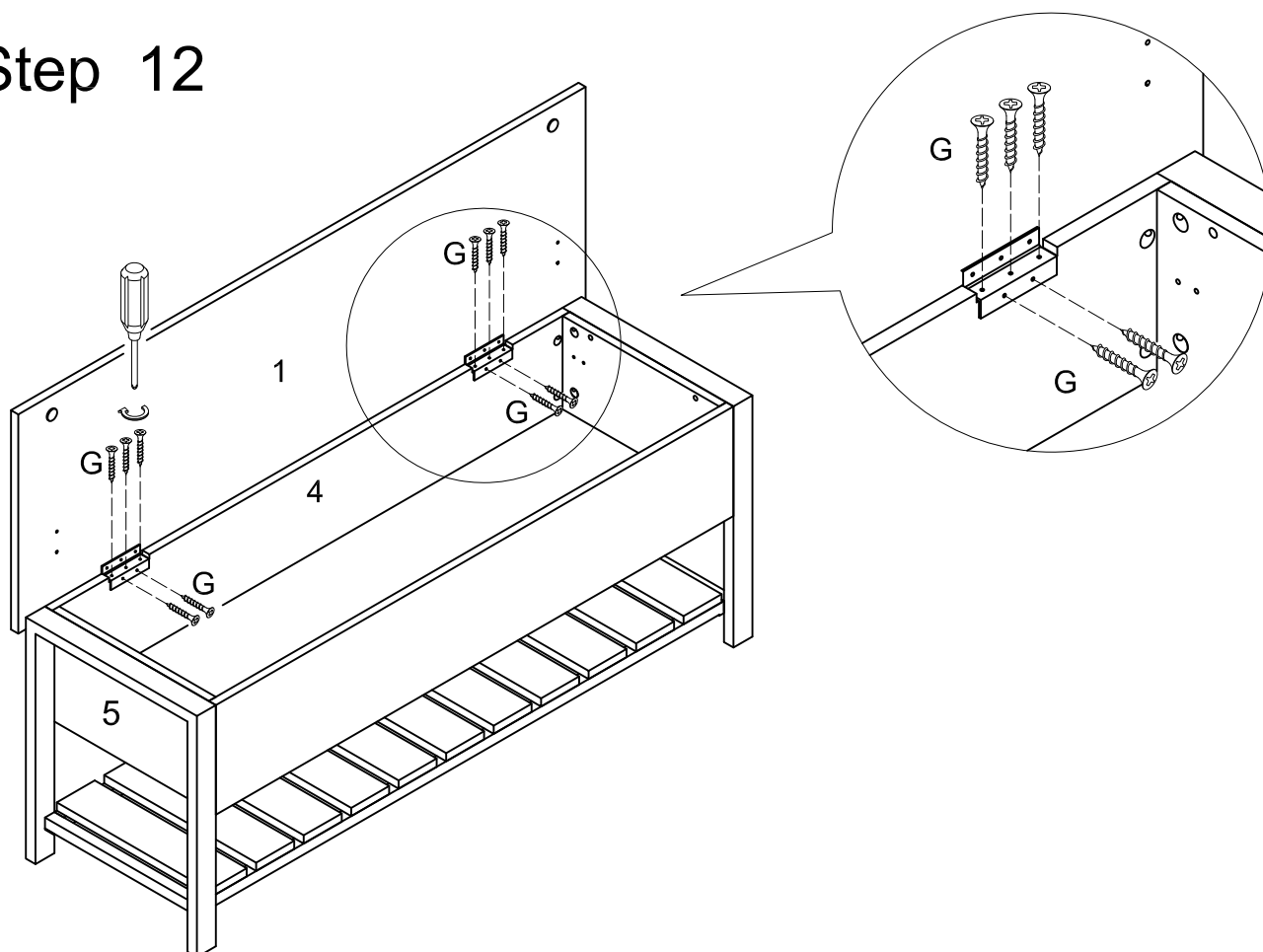

Secure top panel (1) and hinge (H) to panel (4) with screw (G) as per diagram.

## Step 13

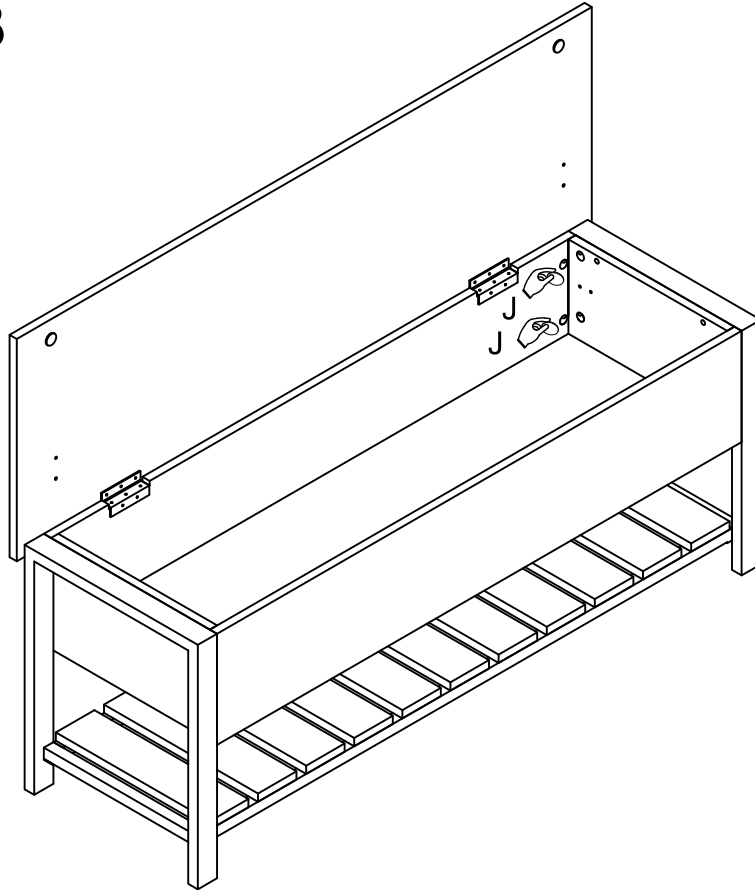

Place sticker (J) over holes as per diagram.

## Step 14

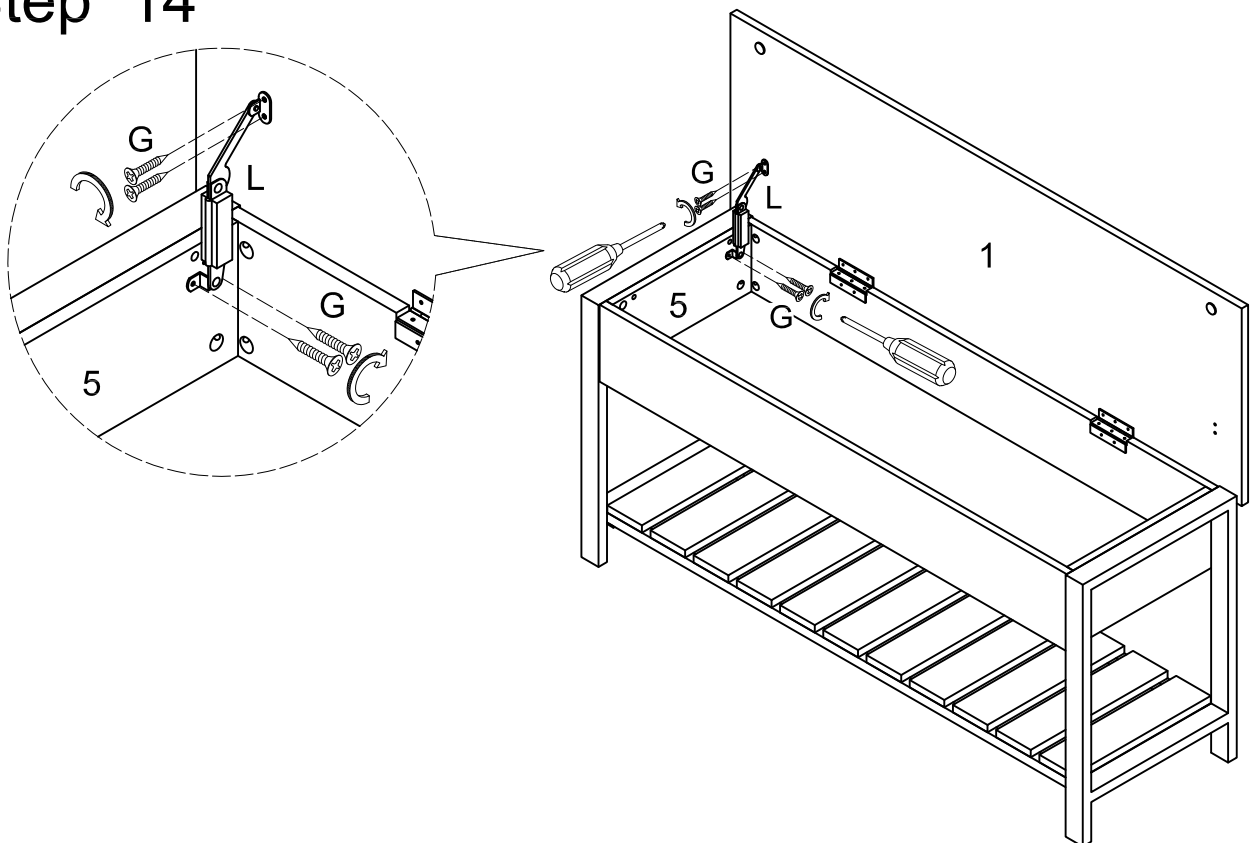

Secure right hinge (L) to side panel (5) and top panel (1) with screw (G).

## Step 15

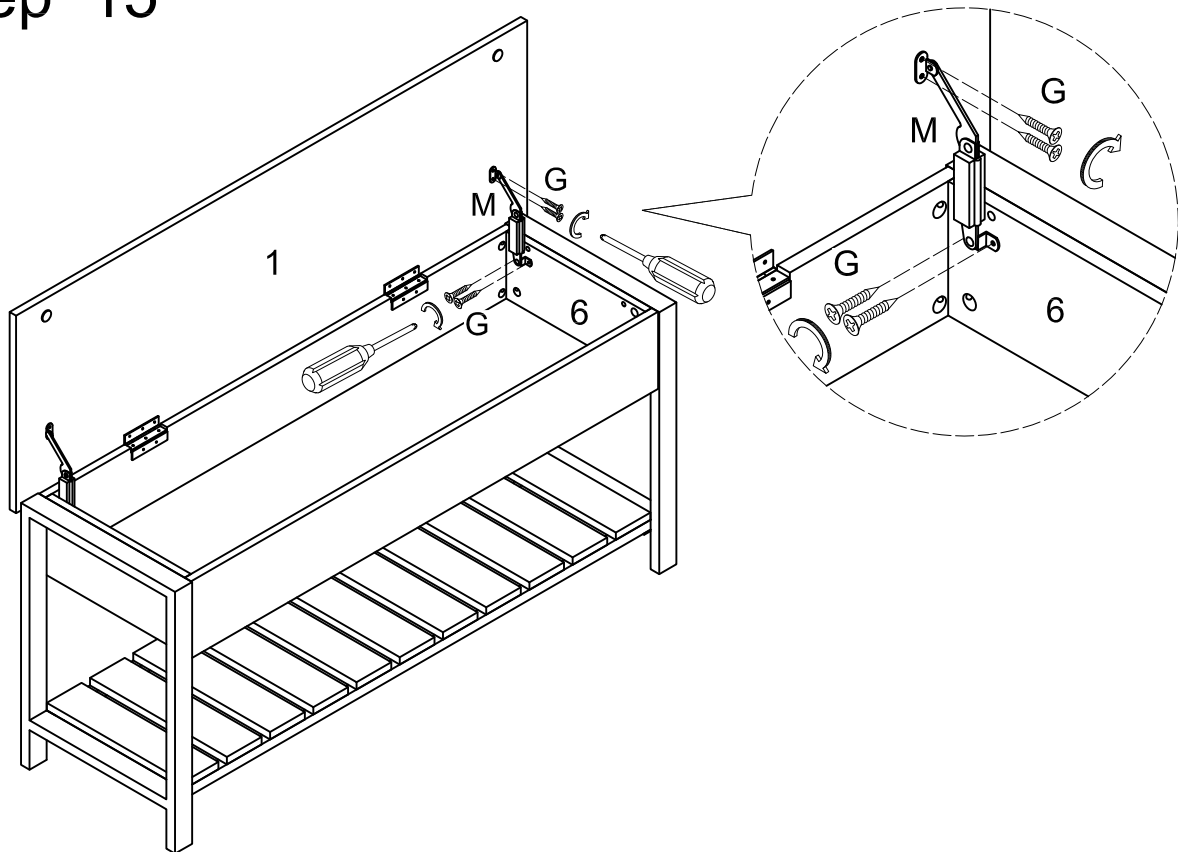

Secure left hinge (M) to side panel (6) and top panel (1) with screw (G).

## Step 16

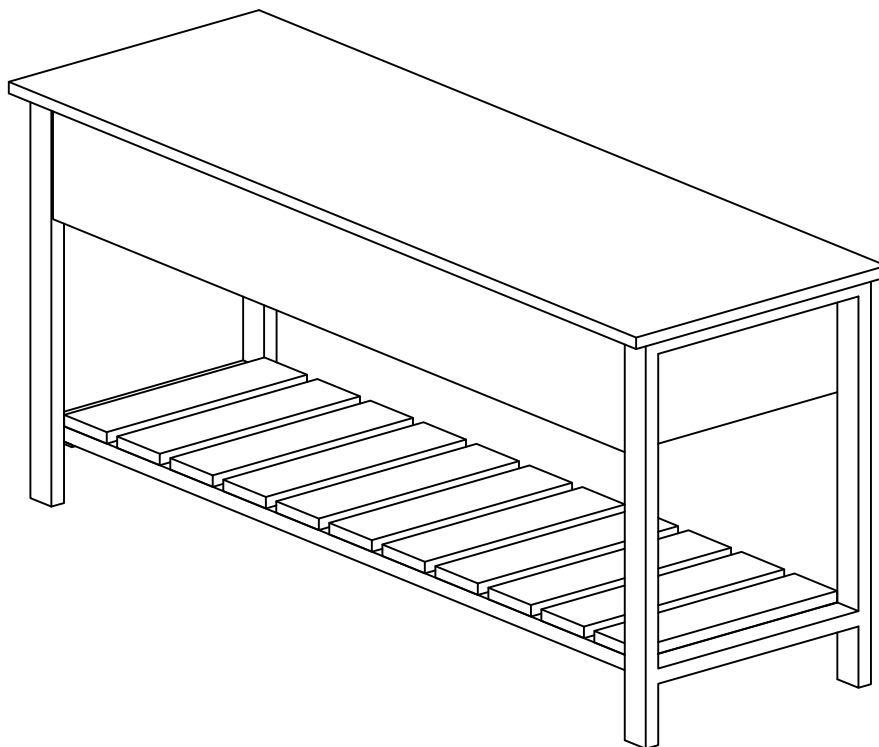

Final Assembly