

CH-BR01-U55

[Chain BR01-U] Brass Rectangle Chandelier Chain

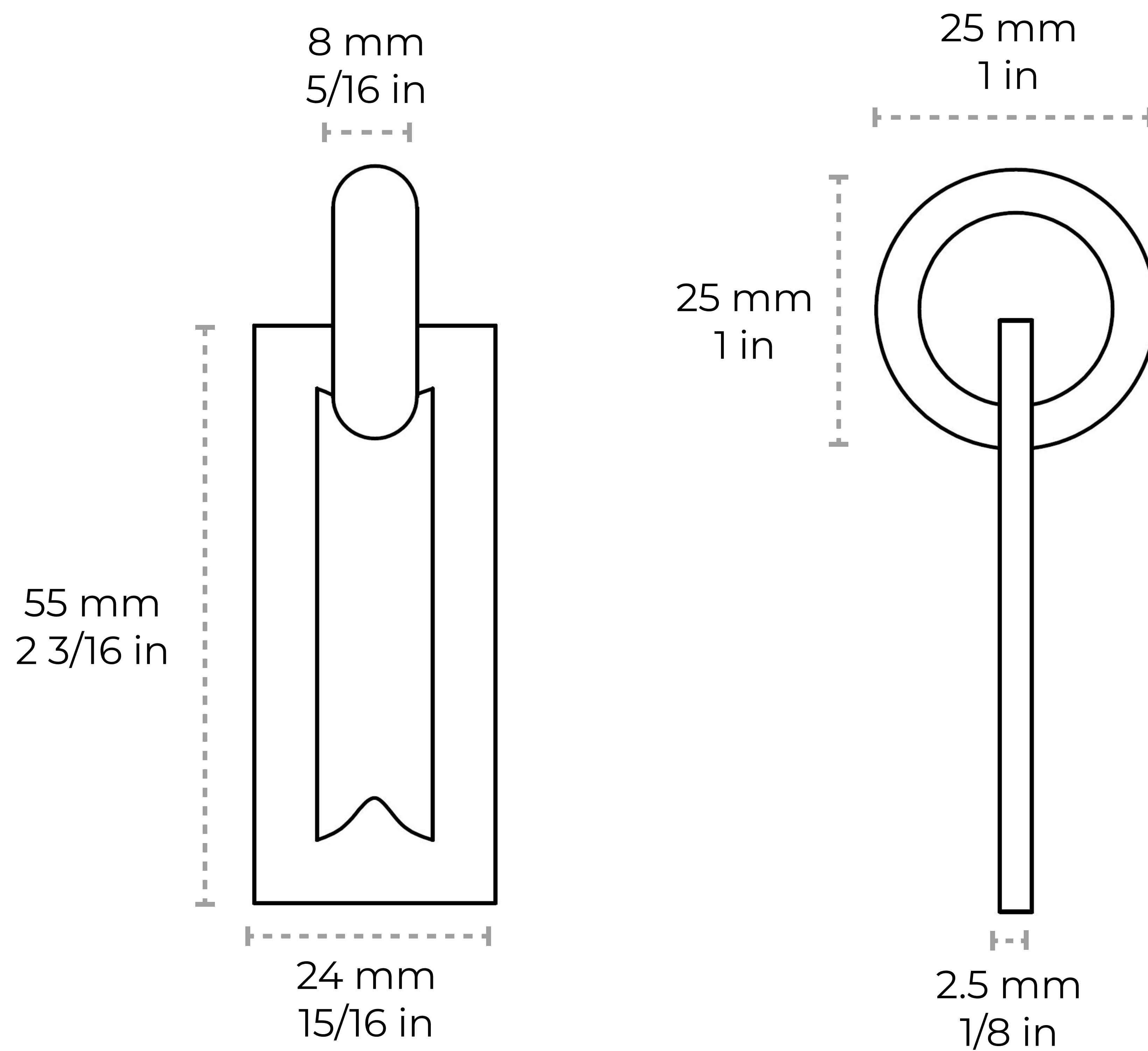

Material	Brass
Welding Type	Unwelded
Max Load	50 lbs
Weight per Foot	0.22 lbs/ft
Main Link Measurements	Length: 55 mm 2 3/16 in Width: 24 mm 15/16 in Diameter: 2.5 mm 1/8 in
Connecting Link Measurements	Length: 25 mm 1 in Width: 25 mm 1 in Diameter: 8 mm 5/16 in

Contact:

1-360-392-8121

<https://www.rchhardware.com>

