

---

## NOTE:

This brochure contains IMPORTANT safety info. Please read and keep for future reference.

---

# MAINTAINANCE AND WARNING

- 1.Keep furniture away from heat sources.
- 2.Do not clean furniture with harsh cleaner or polishes.Do not use detergents,solvents,abrasives,spray packs or leather cleaner. Use non-color mild soa with warm water to clean spills(Mix 1:10 soap to water).
- 3.Do not place furniture under direct sunlight,material will possibly fade over time.
- 4.Do not use on site dry cleaning machine.Children should not climb or jump on the furniture.
- 5.Do not write on furniture that is not protectedby a padded barrier.
- 6.Not for commercial use,only for residential use.



# EXPLOSIVE VIEW

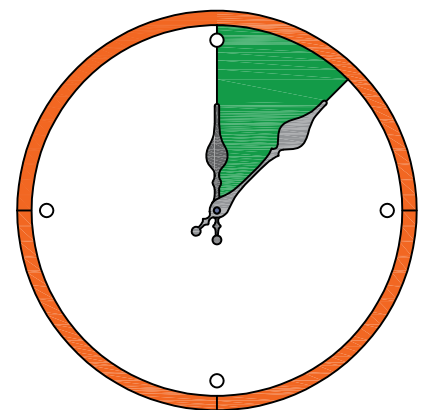
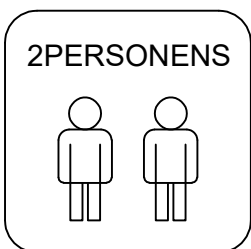
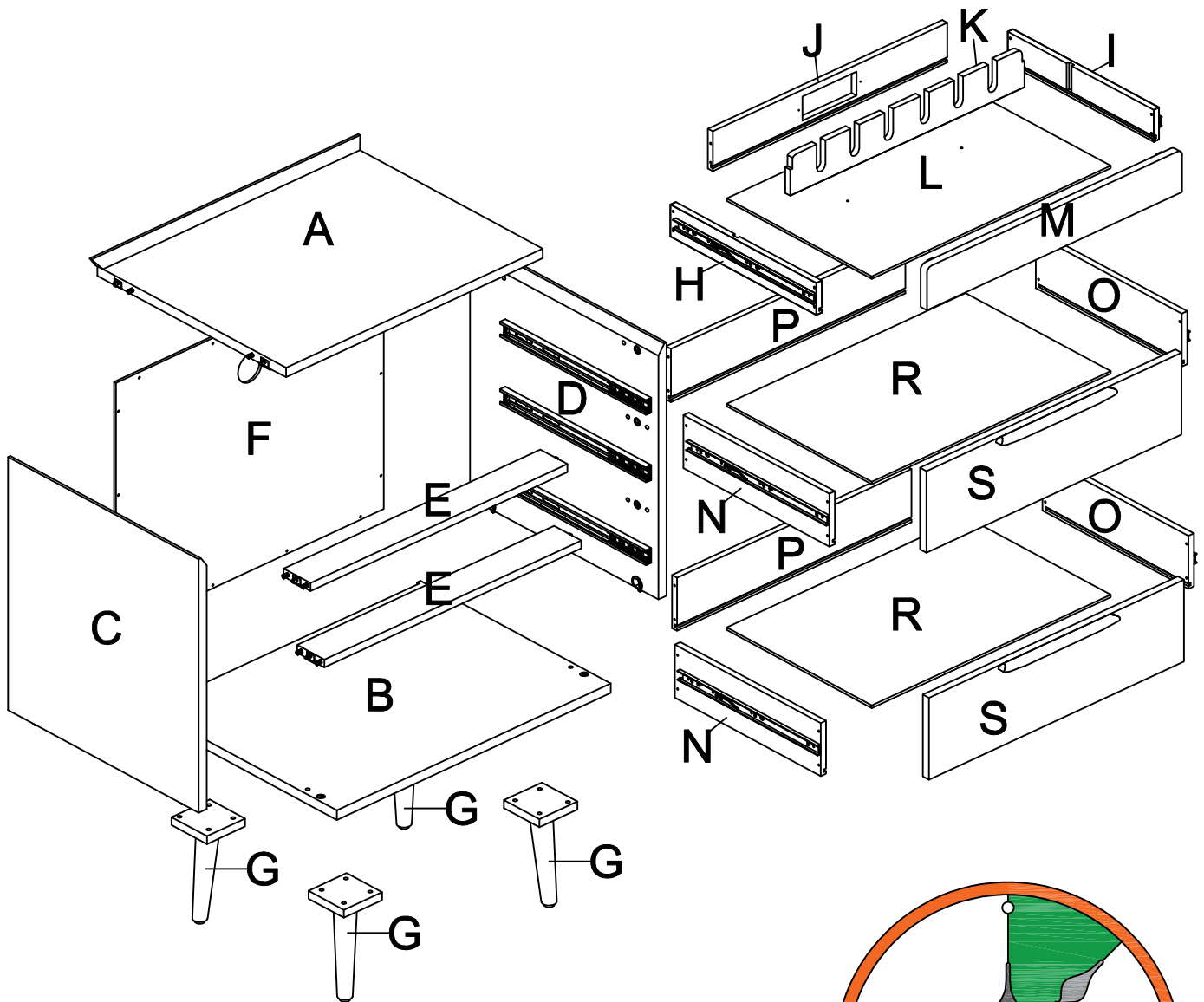

Around **55** min

# PARTS LIST 1

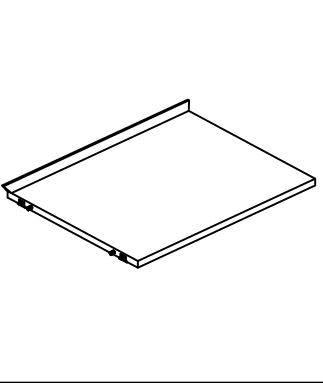
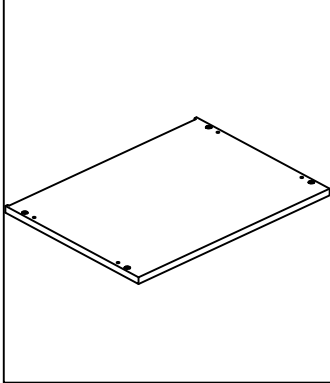
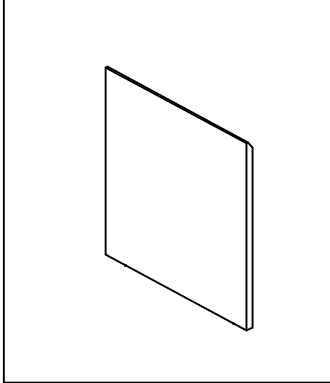
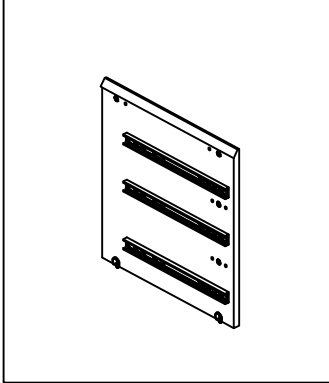
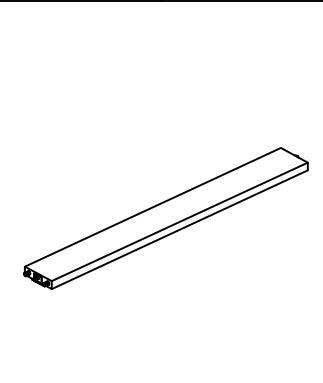
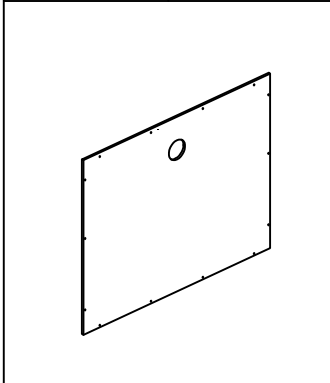
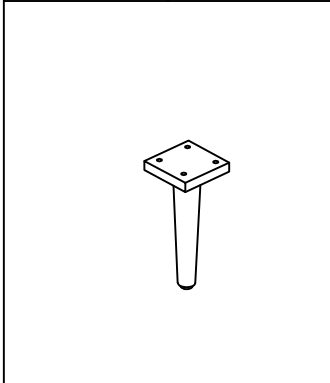
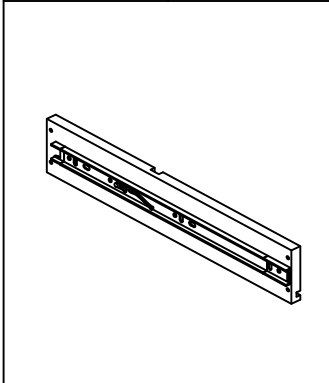
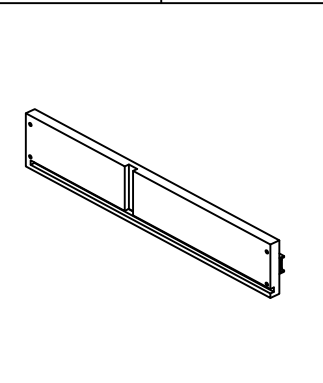
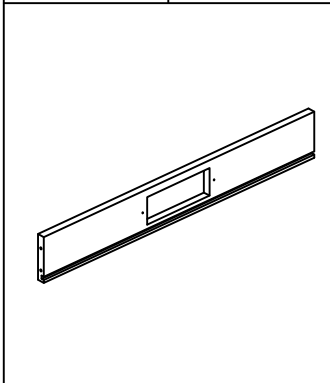
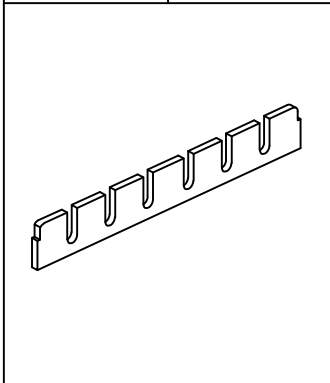
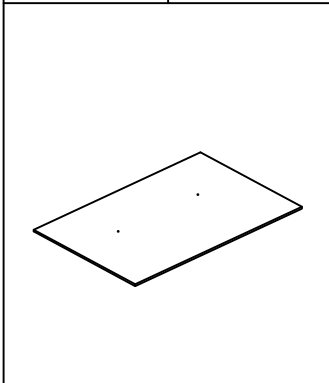
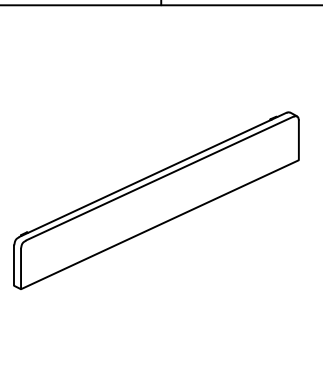
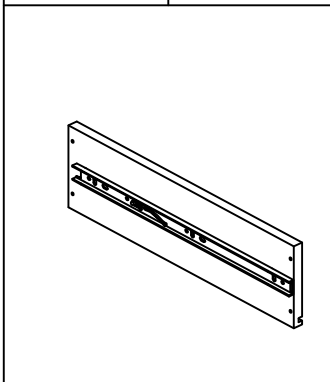
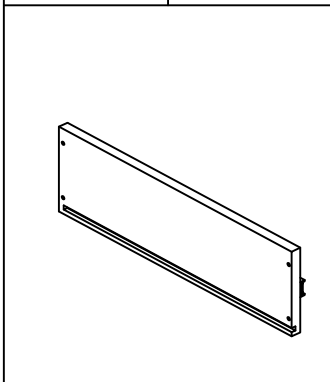
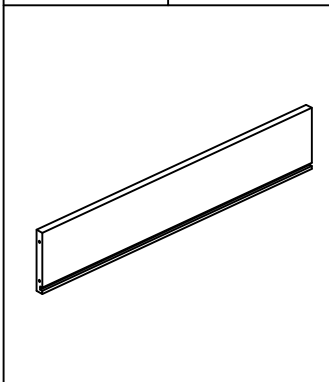



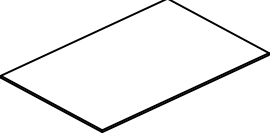

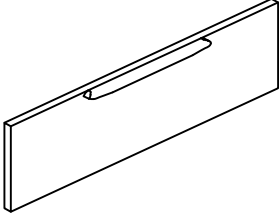

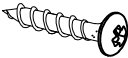

A	x1	B	x1	C	x1	D	x1
							
E	x2	F	x1	G	x4	H	x1
							
I	x1	J	x1	K	x1	L	x1
							
M	x1	N	x2	O	x2	P	x2
							

# PARTS LIST 2

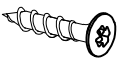
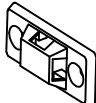
R	x2
	

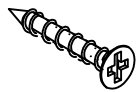
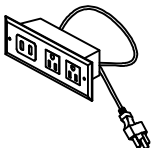
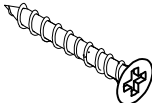
S	x2
	

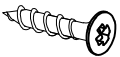

# HARDWARE LIST

#1	x14	#2	x16	#3	x1	#4	x24	#5	x2	#6	x2
											
φ3*16mm		φ6*25mm				φ3*25mm		φ4*15mm			
#7	x1	#8	x1	#10	x2	#11	x1	#12	x2	#13	x2
											
				φ3*16mm				Ø3.5"*38mm		φ3*12mm	
#14	x1	#15	x2								
											
φ3*12mm											

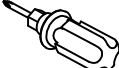
# TOOL LIST

#16	x1	#17	x1
			
M6			

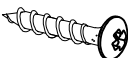
# HARDWARE SPARE LIST

#1	x1	#2	x1	#4	x2
					
φ3*16mm		φ6*25mm		φ3*25mm	

# ASSEMBLY INSTRUCTIONS

## STEP-1

1. insert part (A/E) into panel(C/D), make sure all holes aligned and then tighten it with allen key #16 as picture show.

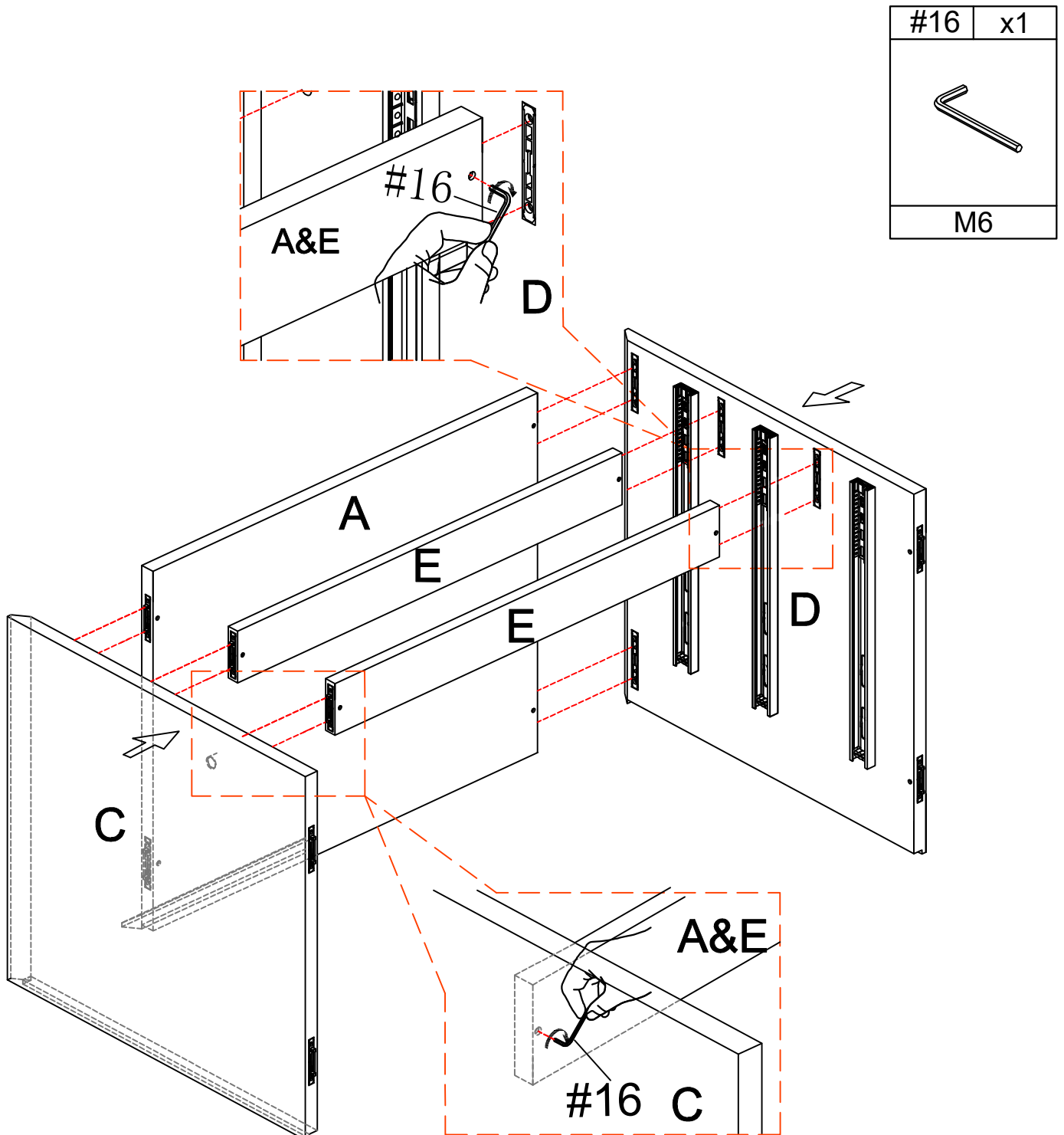

# ASSEMBLY INSTRUCTIONS

## STEP-2

1. insert pre-assembled unit at step 1 to bottom panel(B),make sure all holes aligned and then tighten it with allen key #16 as picture show.

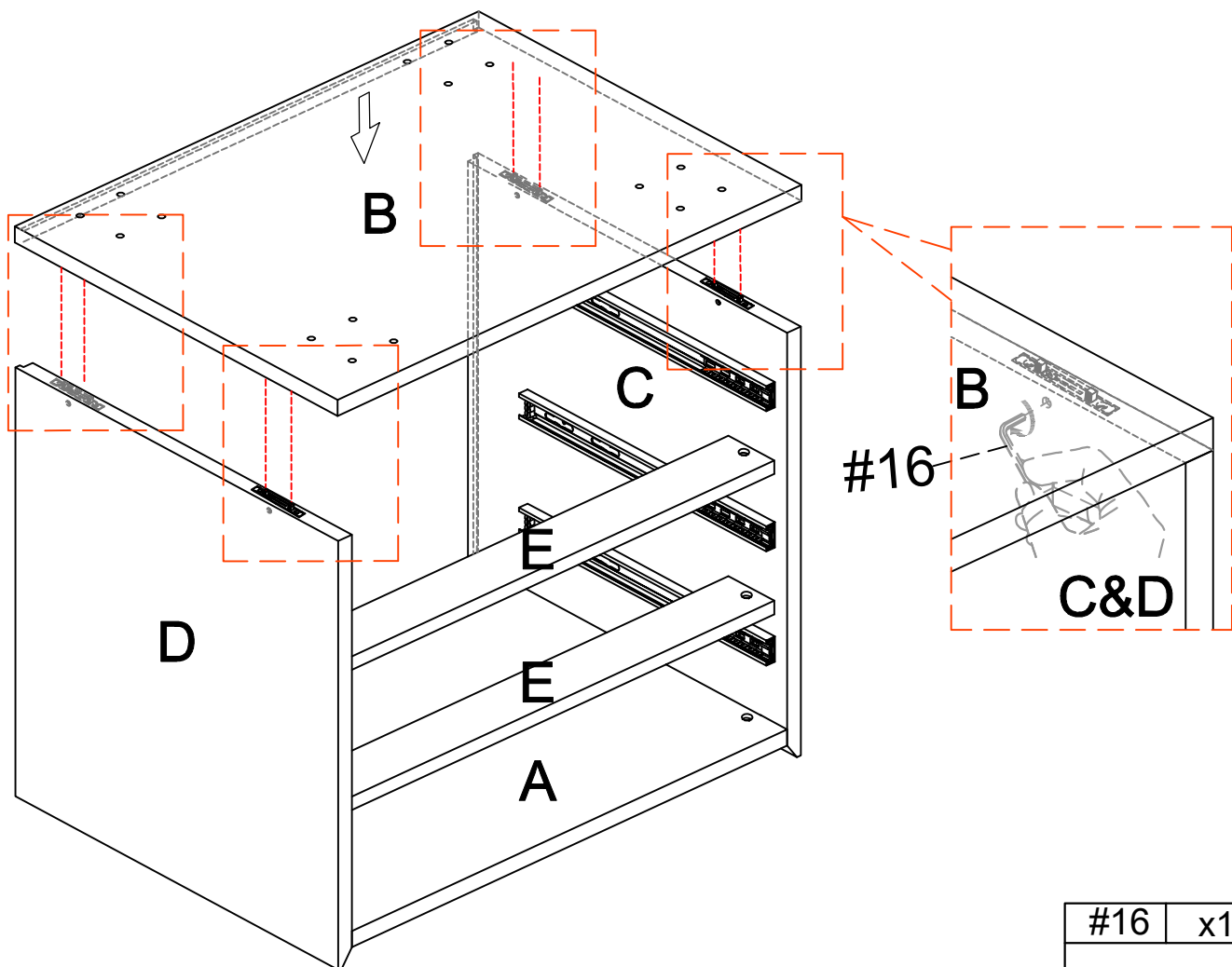



#16	x1
M6	

# ASSEMBLY INSTRUCTIONS

## STEP-3

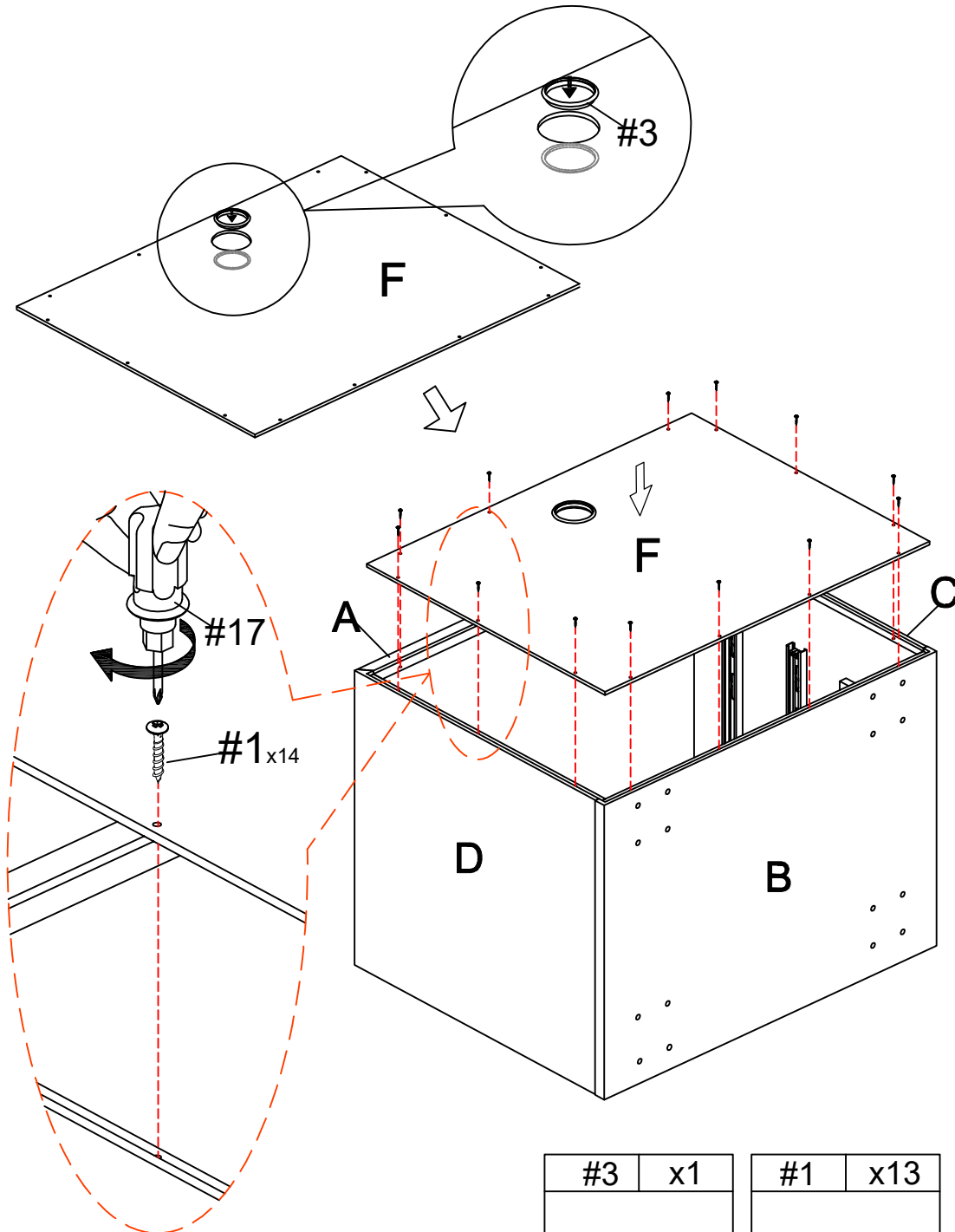
1. Insert the part #3 into the corresponding hole (F) by hand.
2. Attach back panel (F) to pre-assembled unit at step 2 with screw #1, and tighten it with screwdriver #17.



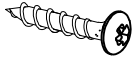
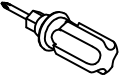

#3	x1	#1	x13	#17	x1
					
		ø3*16mm			

# ASSEMBLY INSTRUCTIONS

## STEP-4

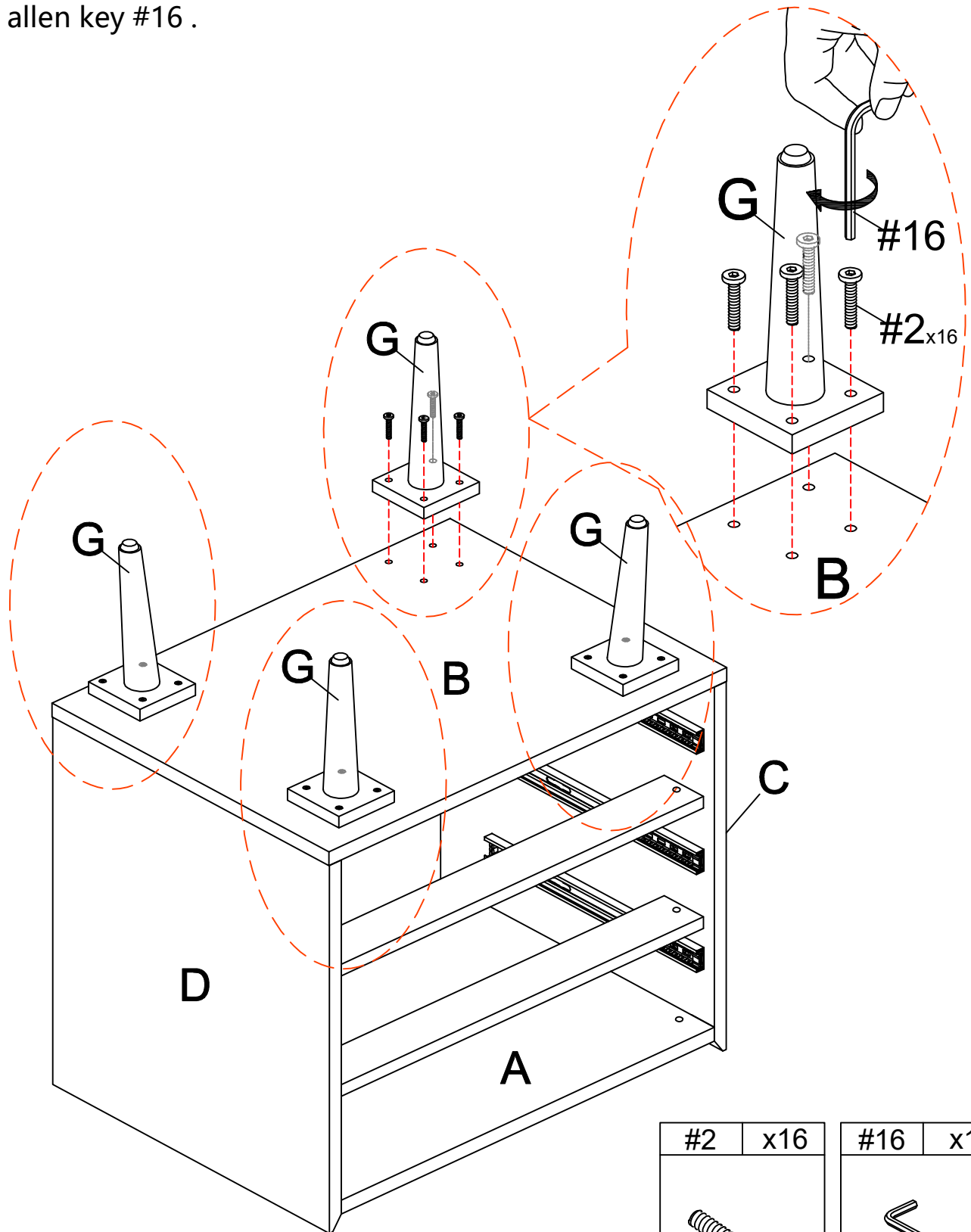
1. Attach leg (G) to the pre-assembled unit in step 3 with #2 bolt and tighten with allen key #16.



#2	x16	#16	x1
			
φ6*25mm		M6	

# ASSEMBLY INSTRUCTIONS

## STEP-5

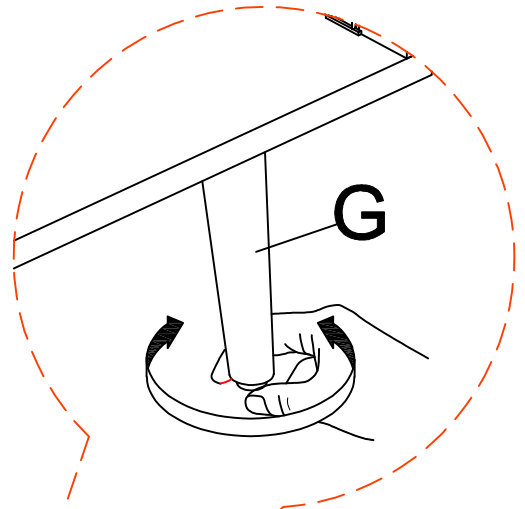
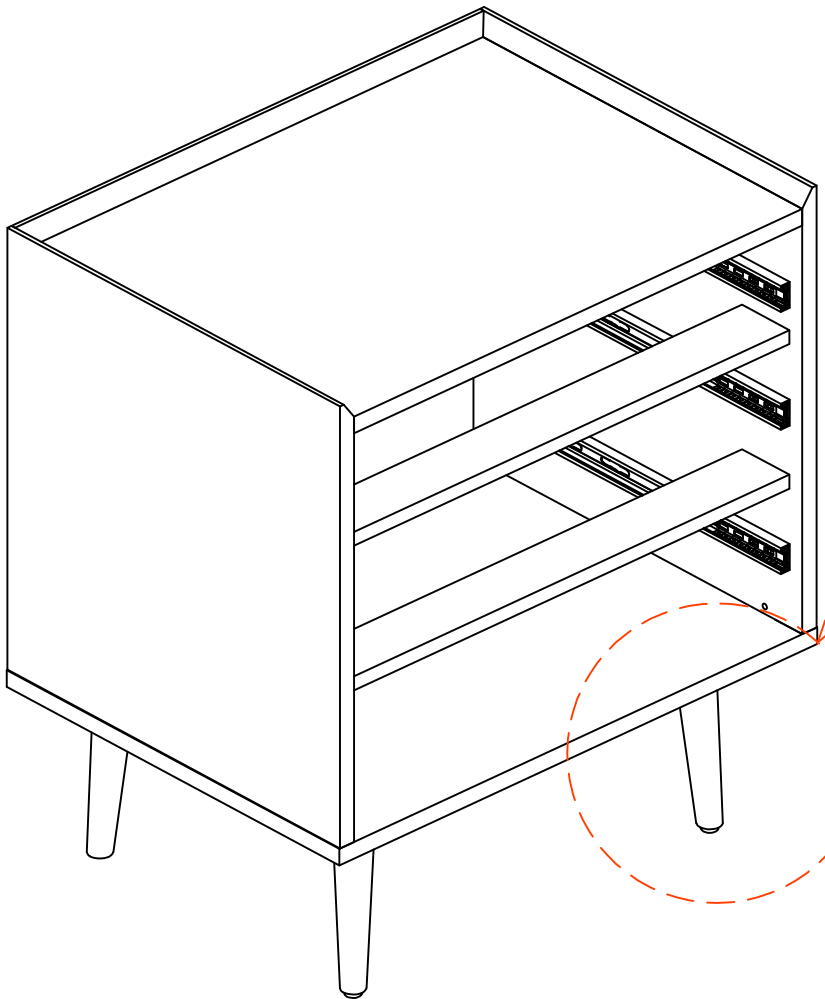

**Attention:**  
Before the next step, adjust the feet of the locker to keep it level.

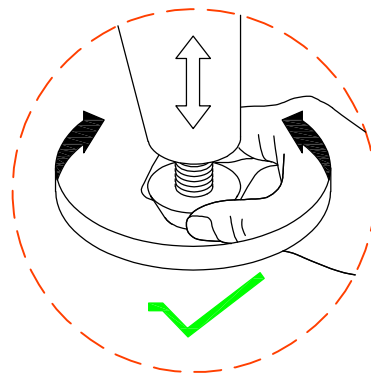
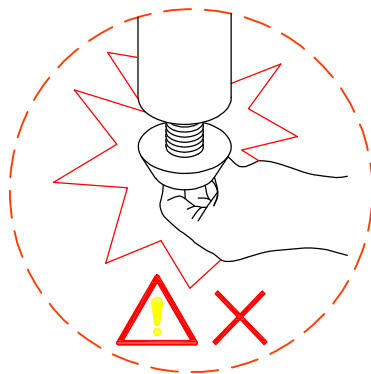

# ASSEMBLY INSTRUCTIONS

## STEP-6

1. connect part (H/I) to part (M) with screw #4, tight screw with screwdriver #17.
2. slide part (L) into the groove in part (H/I), make sure it also in the groove of part (M).

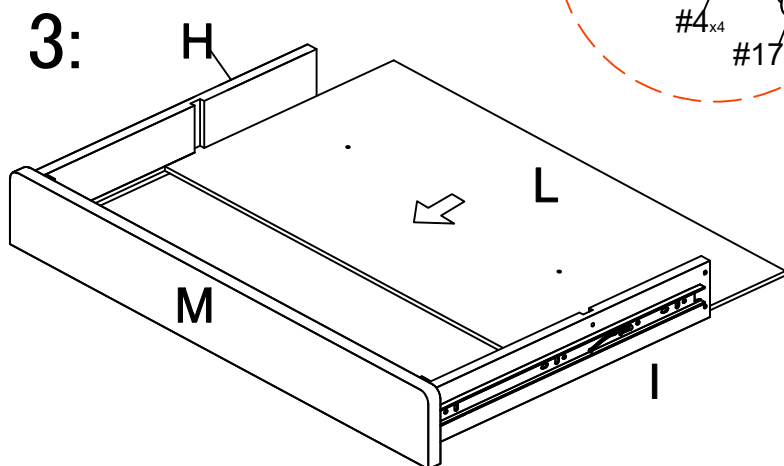
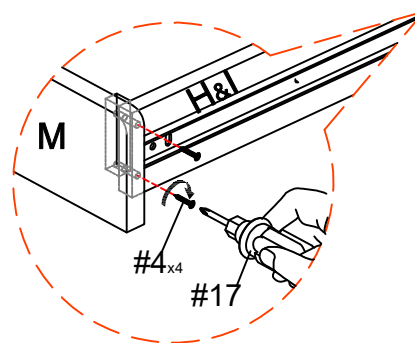
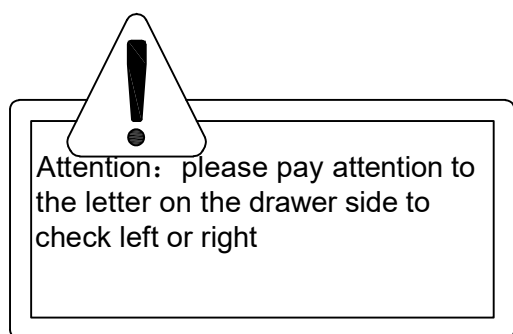
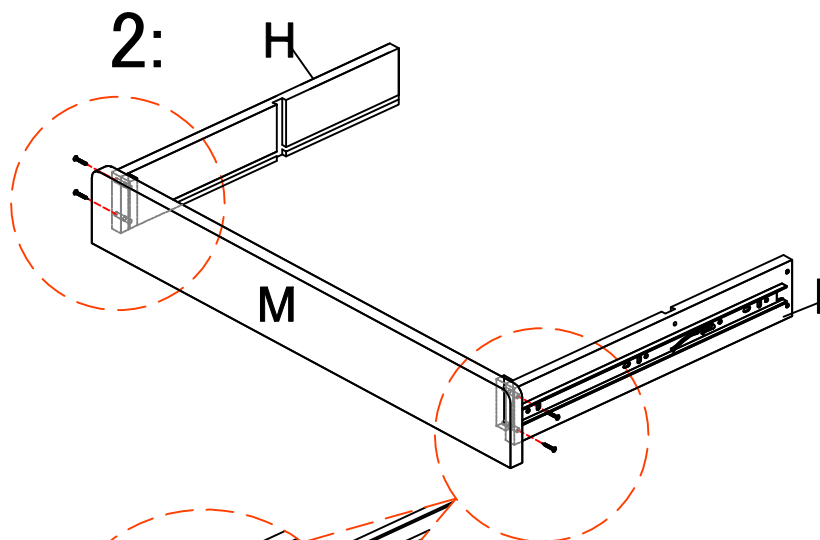
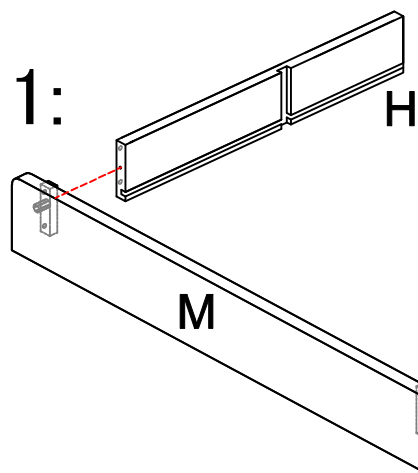

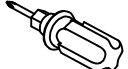

#4	x4	#17	x1
			
ø3*25mm			

# ASSEMBLY INSTRUCTIONS

## STEP-7

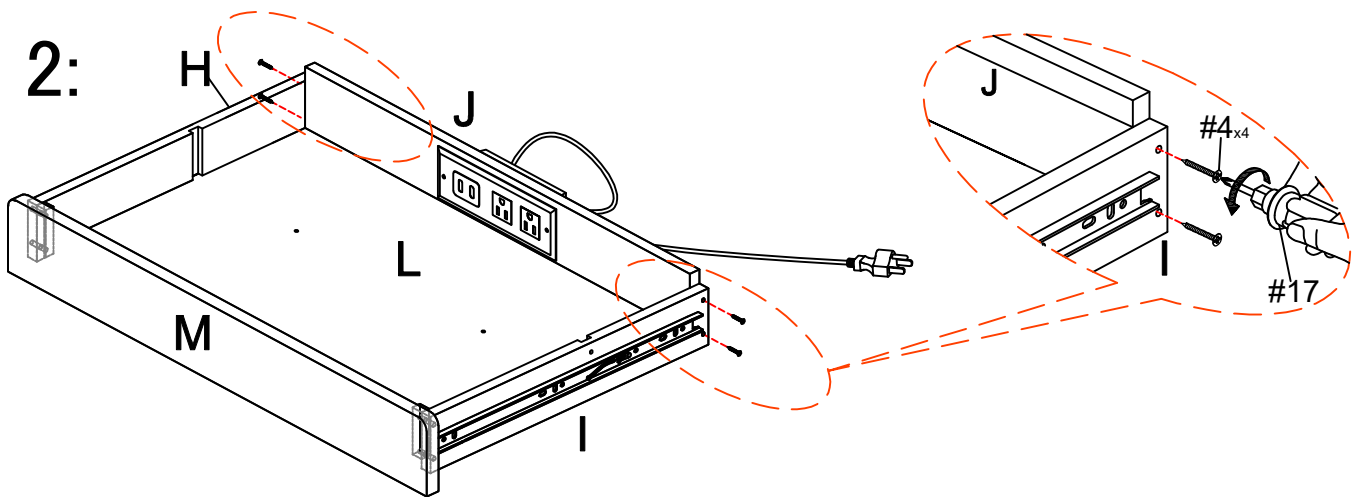
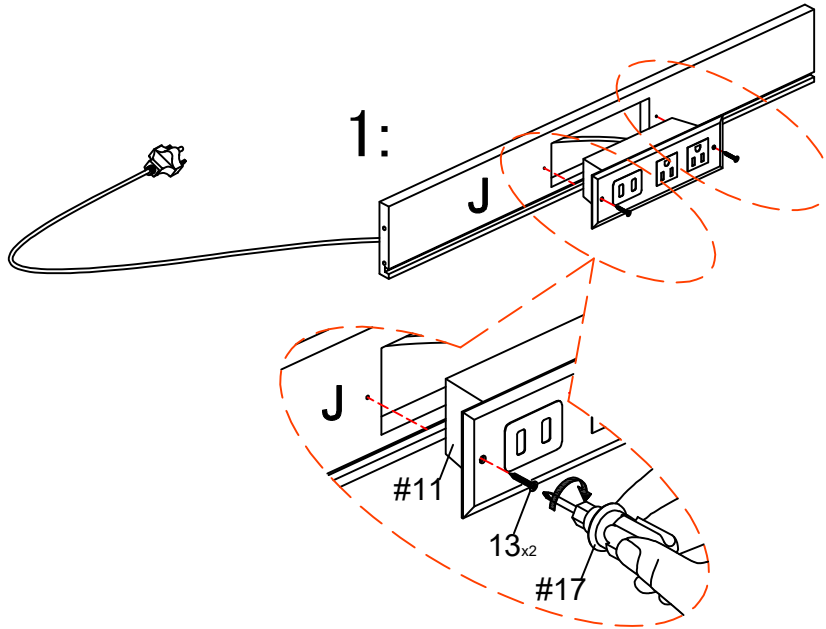
1. Connect socket #11 to part (J) using screw #13. and tighten it with screwdriver #17.
2. Connect part (H&I) to part (J) using screw #4 and tighten it with screwdriver #17.



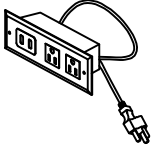
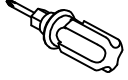

#4	x4	#13	x2	#11	x1	#17	x1
							
φ3*25mm		φ3*12mm					

# ASSEMBLY INSTRUCTIONS

## STEP-8

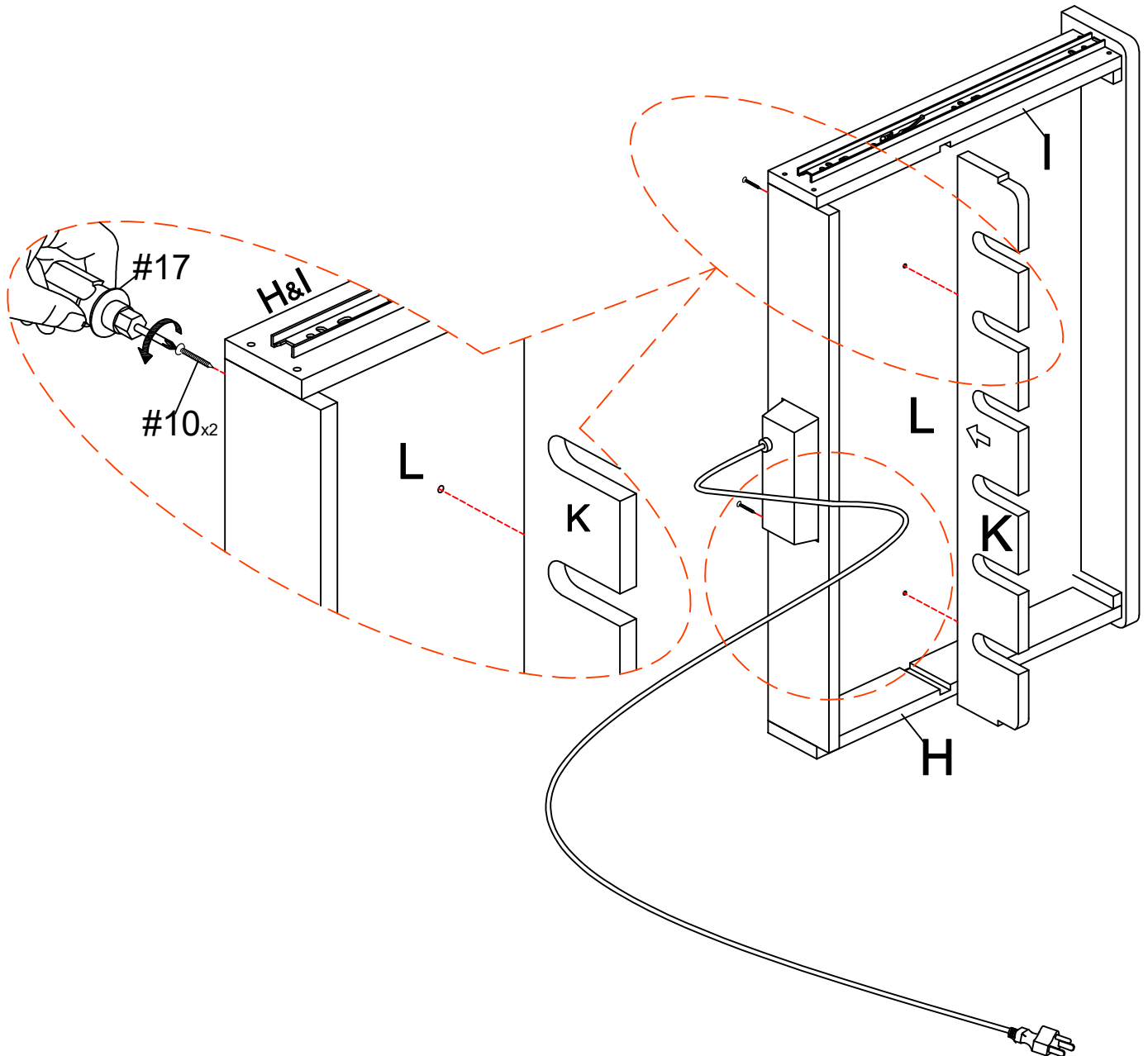
1. Attach part (K) to the pre-assembled unit at step 7 with #10 screw, and tighten it with screwdriver #17.

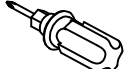

#10	x2	#17	x1
			
ø3*16mm			

# ASSEMBLY INSTRUCTIONS

## STEP-9

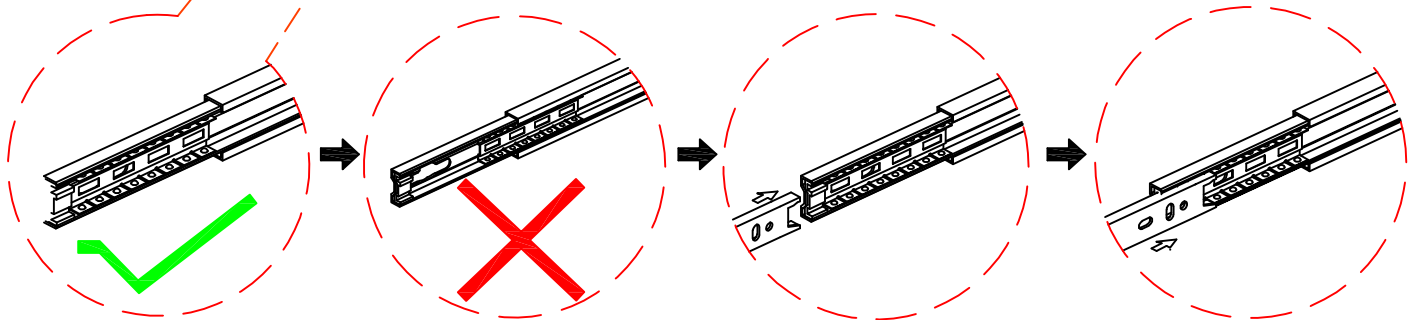
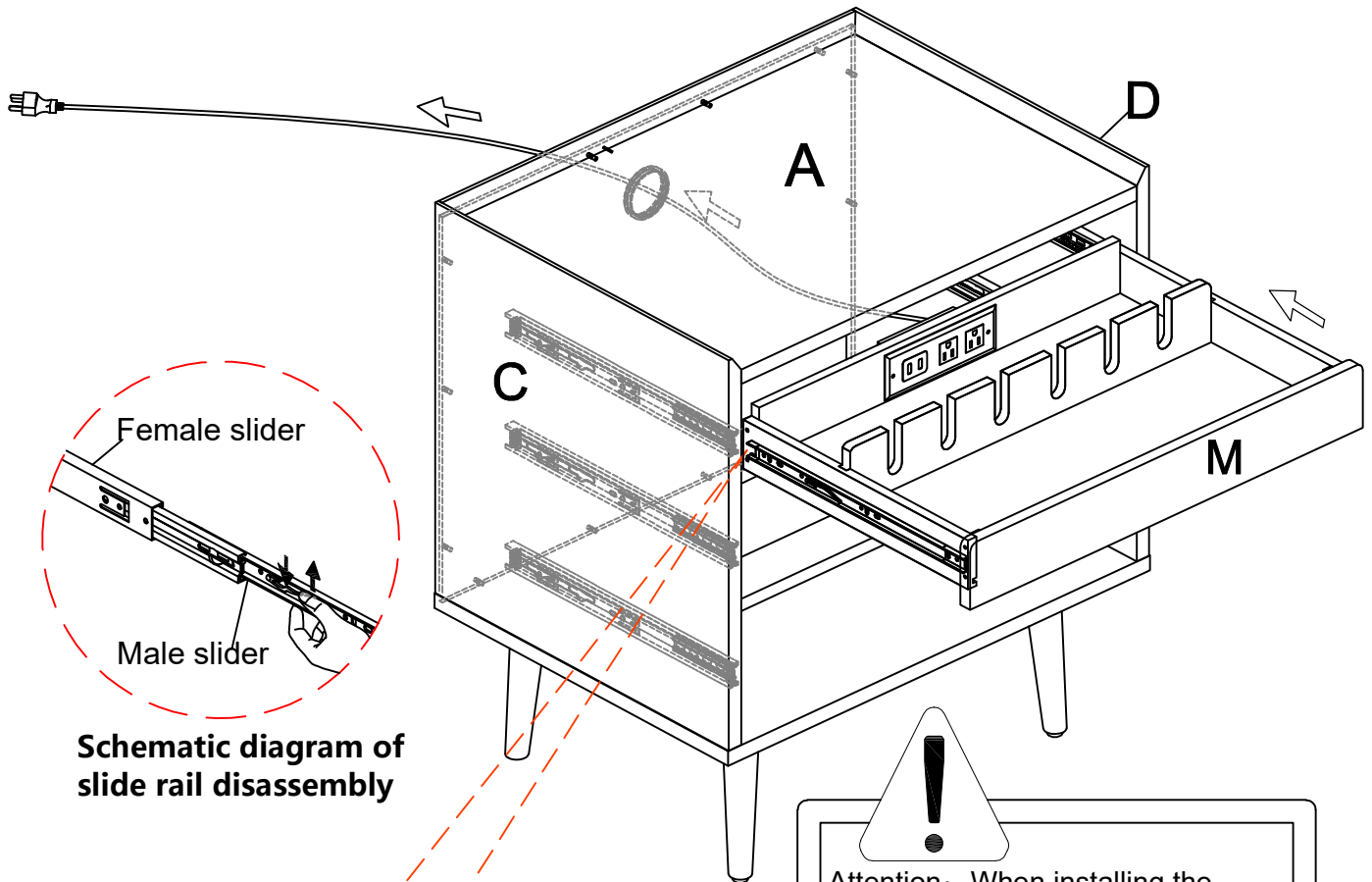



# ASSEMBLY INSTRUCTIONS

## STEP-10

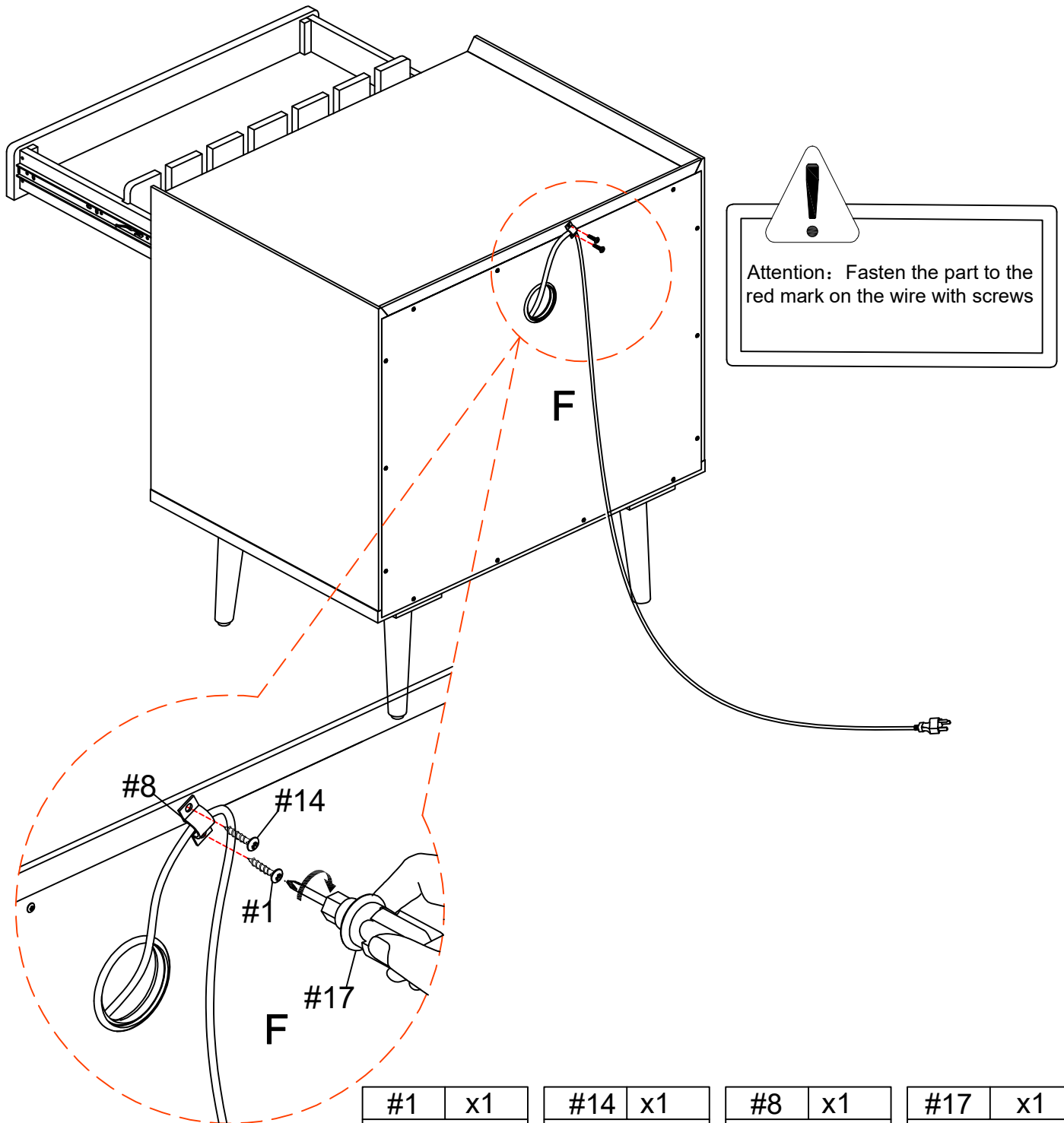
1. Attach part #8 to the pre-assembled unit at step 9 with #1 screw and #14 screw, and tighten it with screwdriver #17.

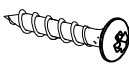
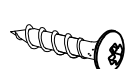

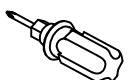

#1	x1	#14	x1	#8	x1	#17	x1
							
ø3*16mm		ø3*12mm					

# ASSEMBLY INSTRUCTIONS

## STEP-11

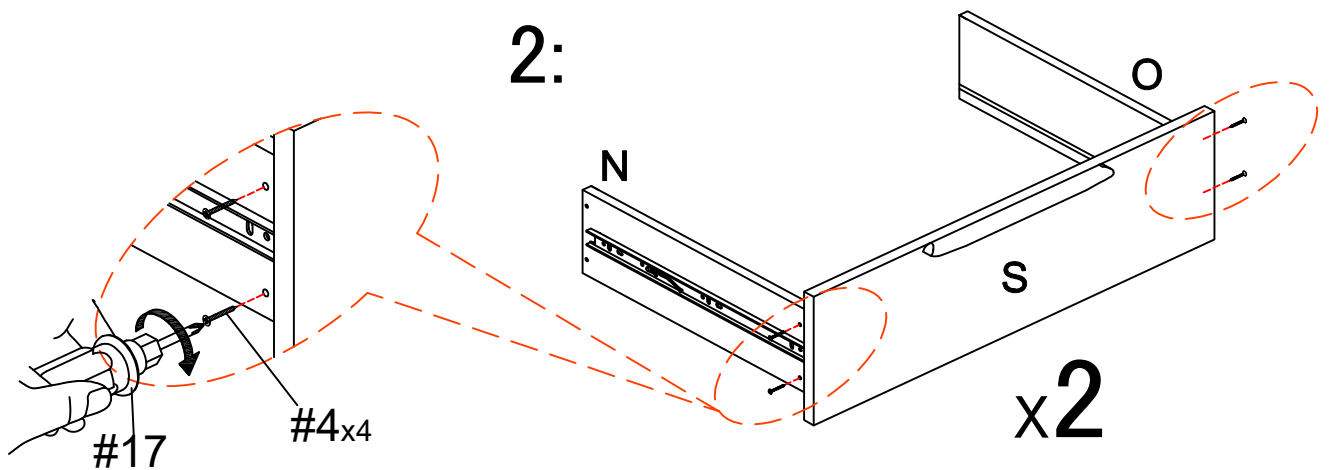
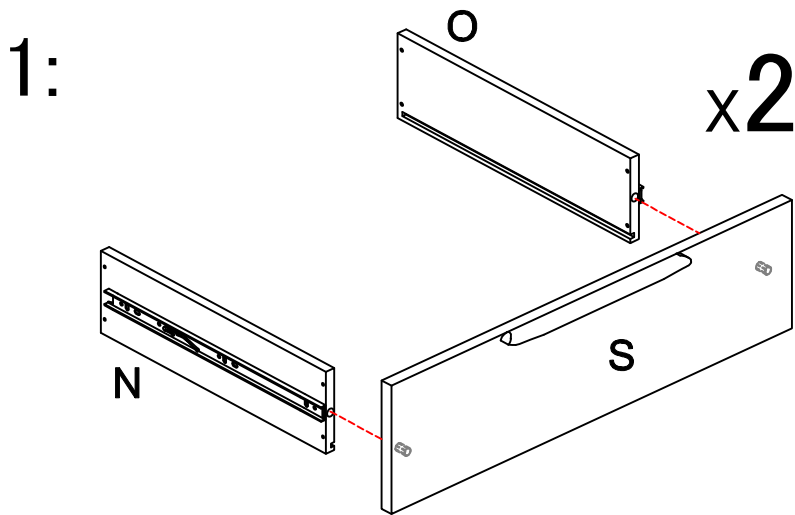
1. Connect part (N&O) to part (S) using screw #4 and tighten it with screwdriver #17.

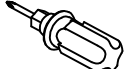

#4	x8	#17	x1
			
ø3*25mm			

# ASSEMBLY INSTRUCTIONS

## STEP-12

1.2. Slide in the part (R) into the groove in part (N&O) . make sure they are also in groove in part (S).

2. Connect the (P) connection (N&O) using screw #4 , and tighten it with screwdriver #17.

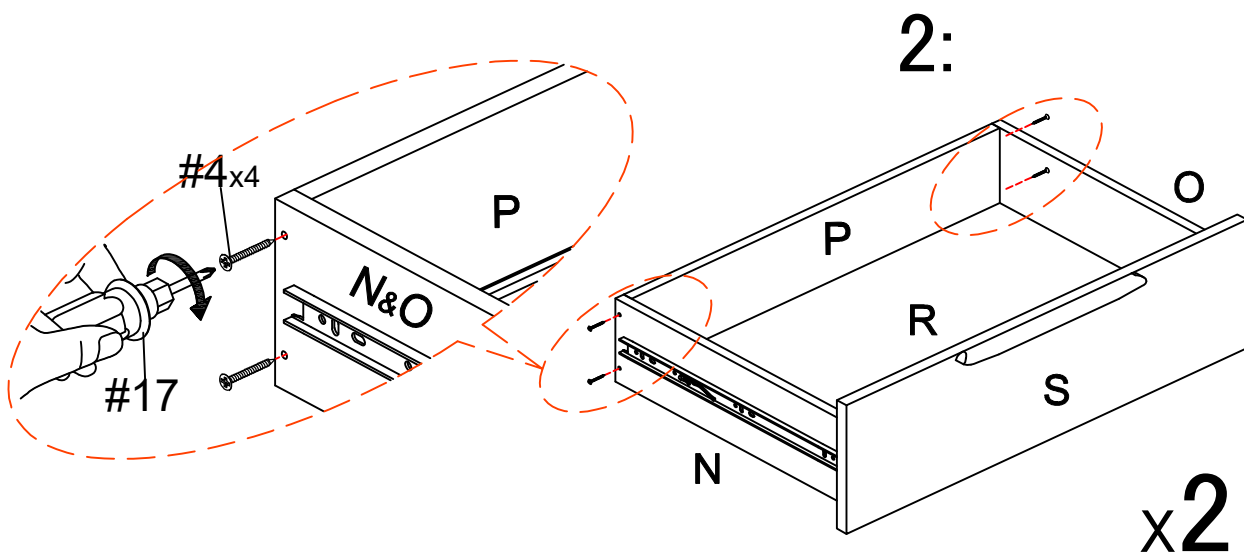
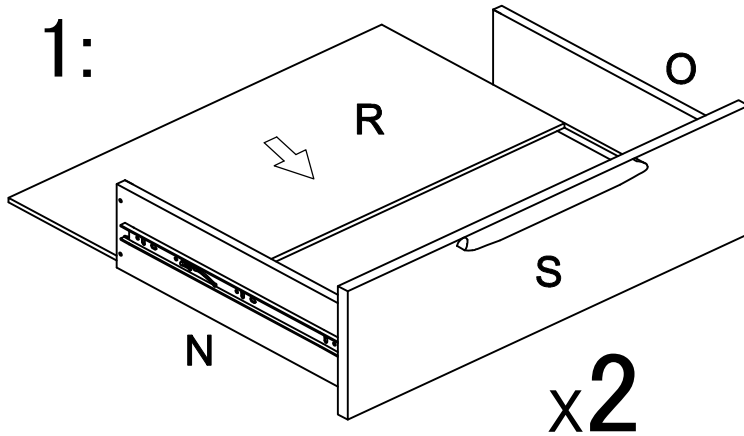

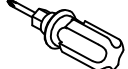
#4	x8	#17	x1
			
ø3*25mm			

# ASSEMBLY INSTRUCTIONS

## STEP-13

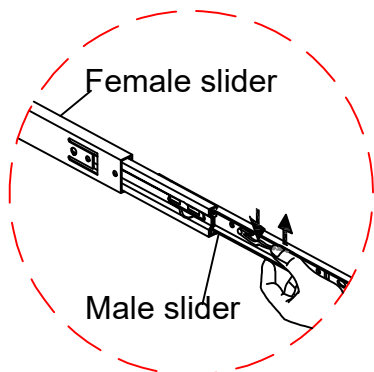
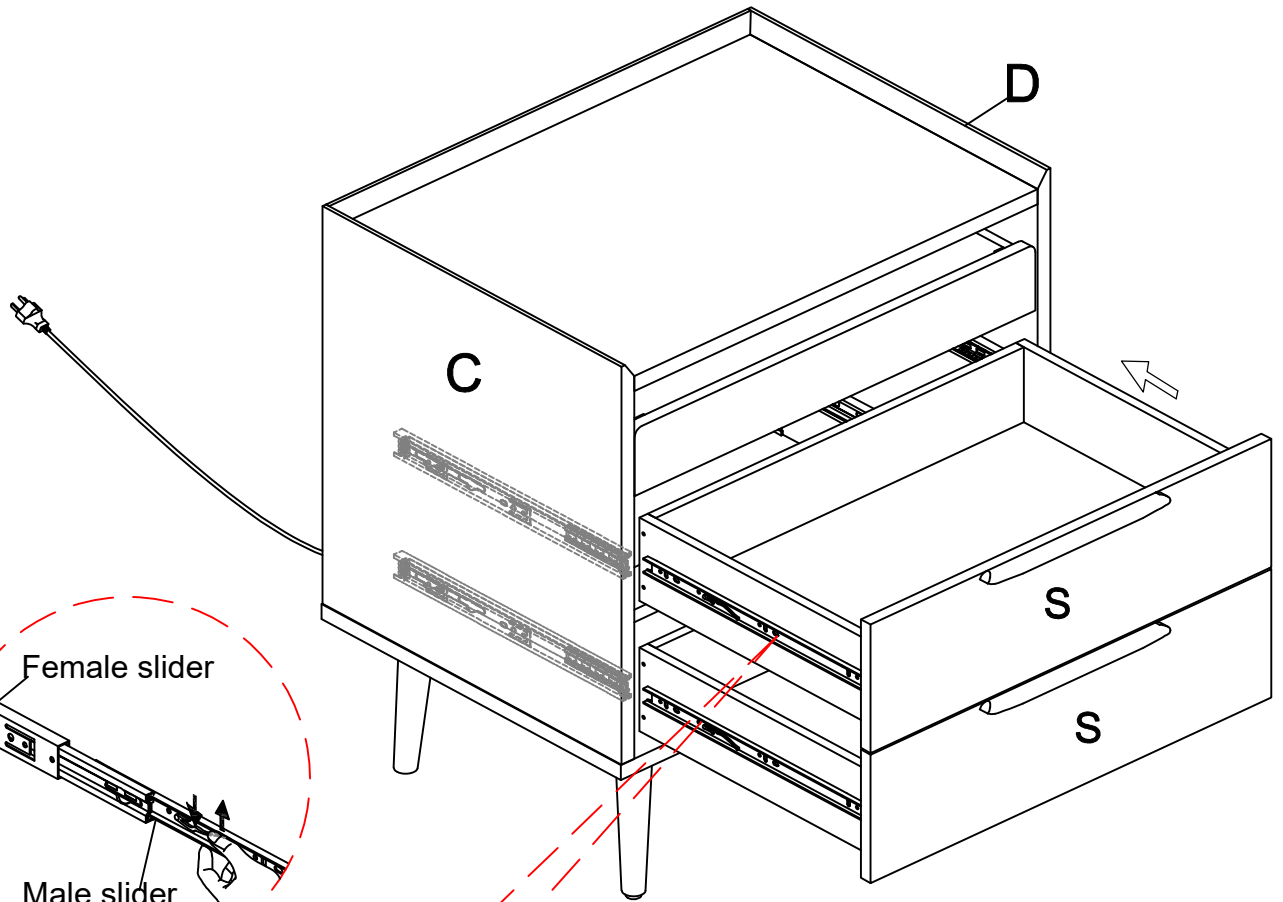

**Schematic diagram of slide rail disassembly**

**Attention:** When installing the drawer, slide the steel ball slide rail of side panel to the most front as picture show.

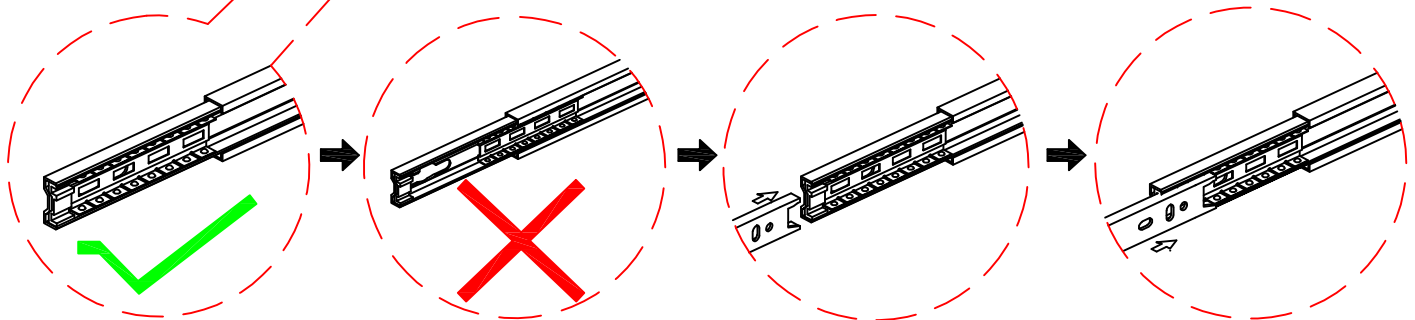

# ASSEMBLY INSTRUCTIONS

## STEP-14

1. use screw #5 to attach plastic bracket #6 to panel (A), make sure all holes aligned and tighten screw #5 with screwdriver #17.

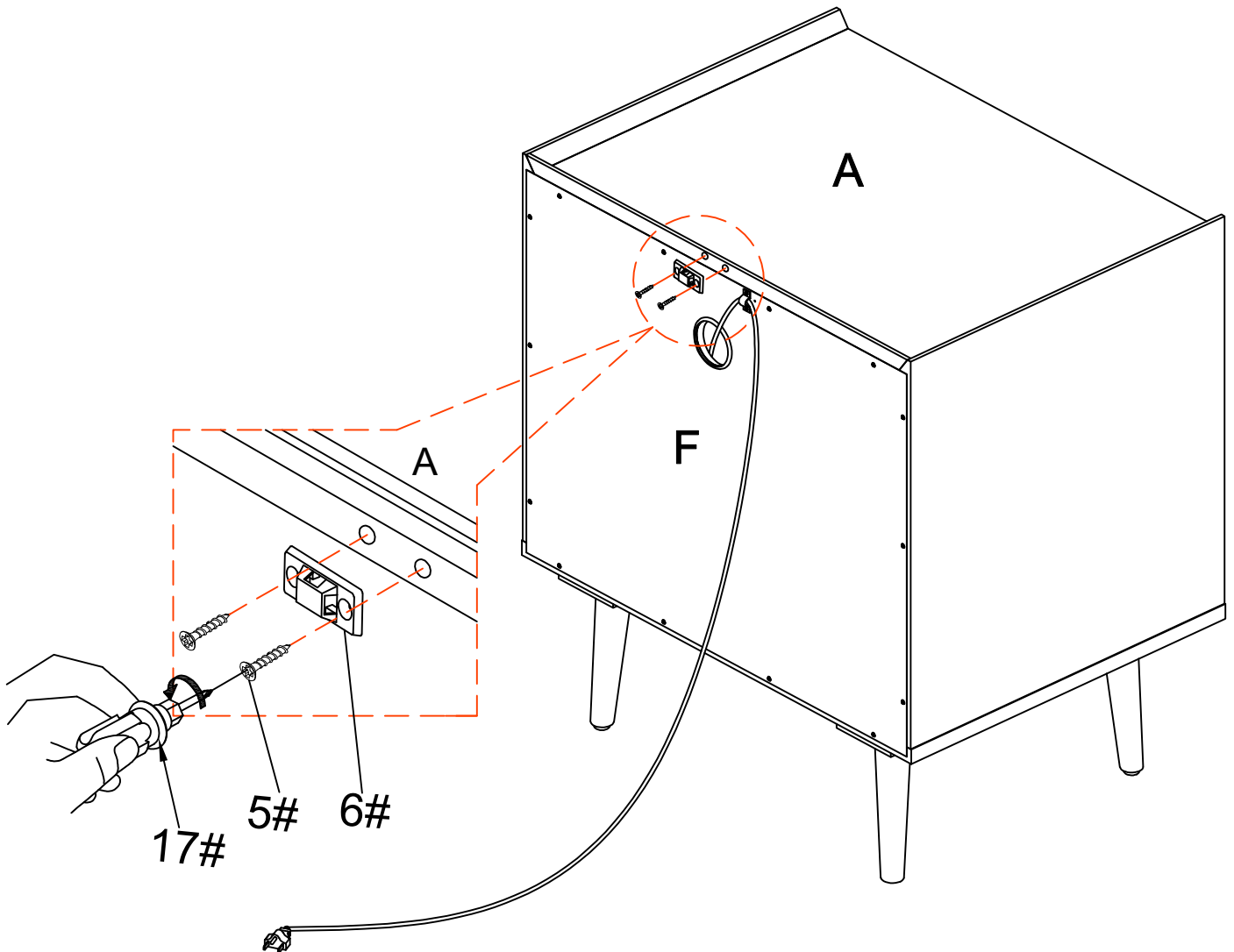

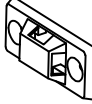
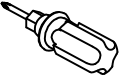
#5	x2	#6	x1	#17	x1
					
ø4*15mm					

# ASSEMBLY INSTRUCTIONS

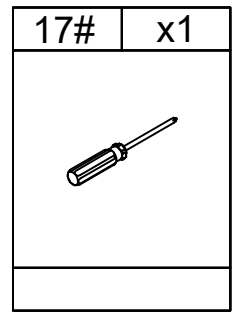
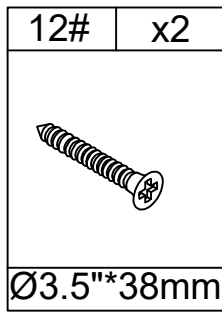
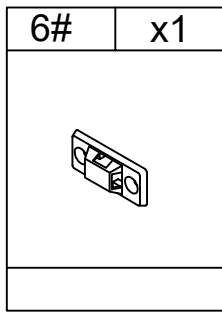
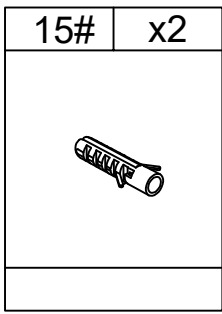

## STEP-15

1. Install the anti-collapse device.
2. Mark the position on the wall, that corresponds to the location of part (6#) on the Top panel (A); Drill and insert the expandable screw (15#) by hammer.
3. Assemble the part (6#) to the wall. Align the hole in the part (6#) with the expandable screw (15#), use screw (12#) to attach it and tighten by screwdriver (17#).

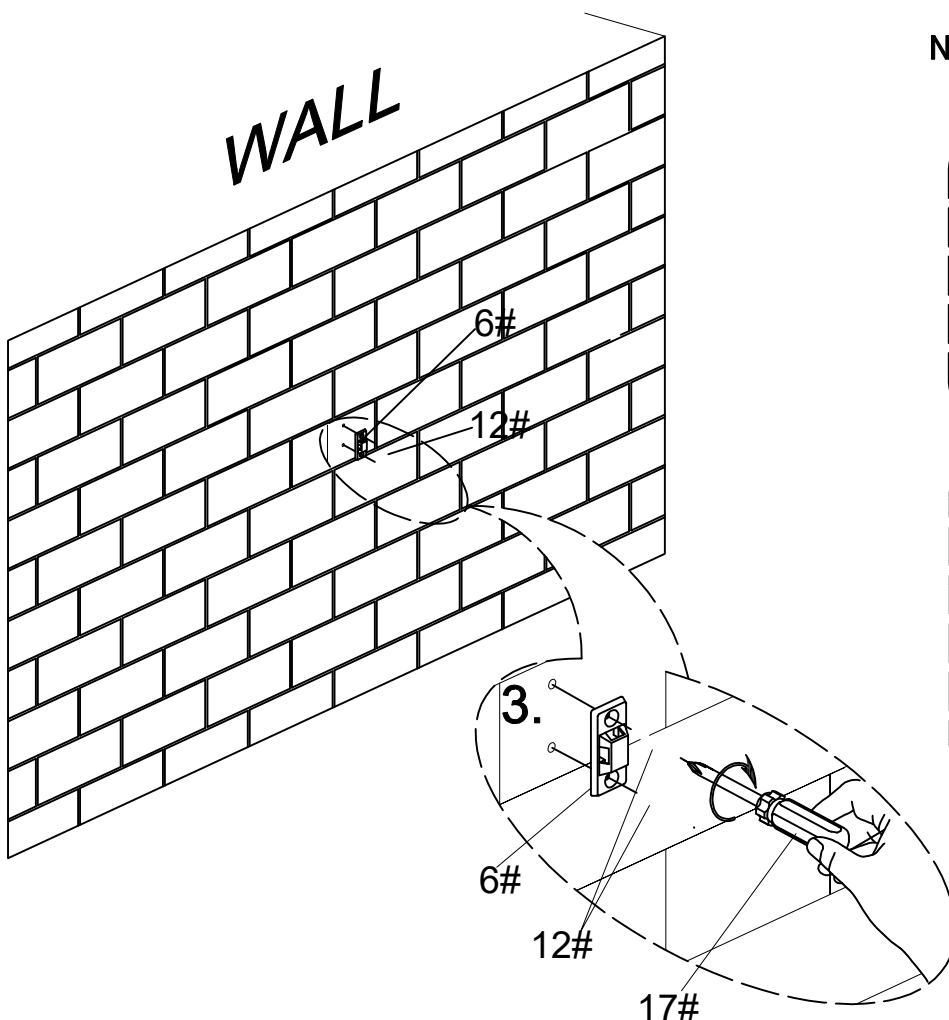

NOT PROVIDED

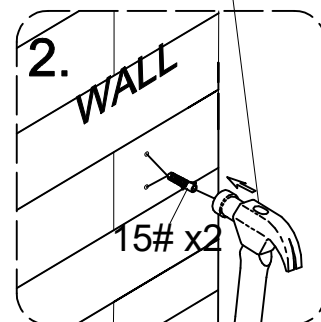
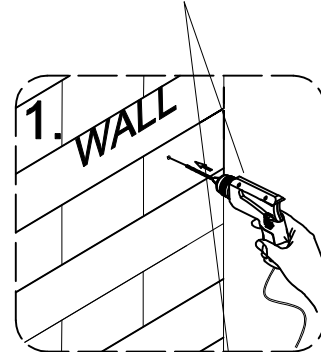

# ASSEMBLY INSTRUCTIONS

## STEP-16

1. Let the plastic belt (7#) pass through the both part (6#) and pull tightly.

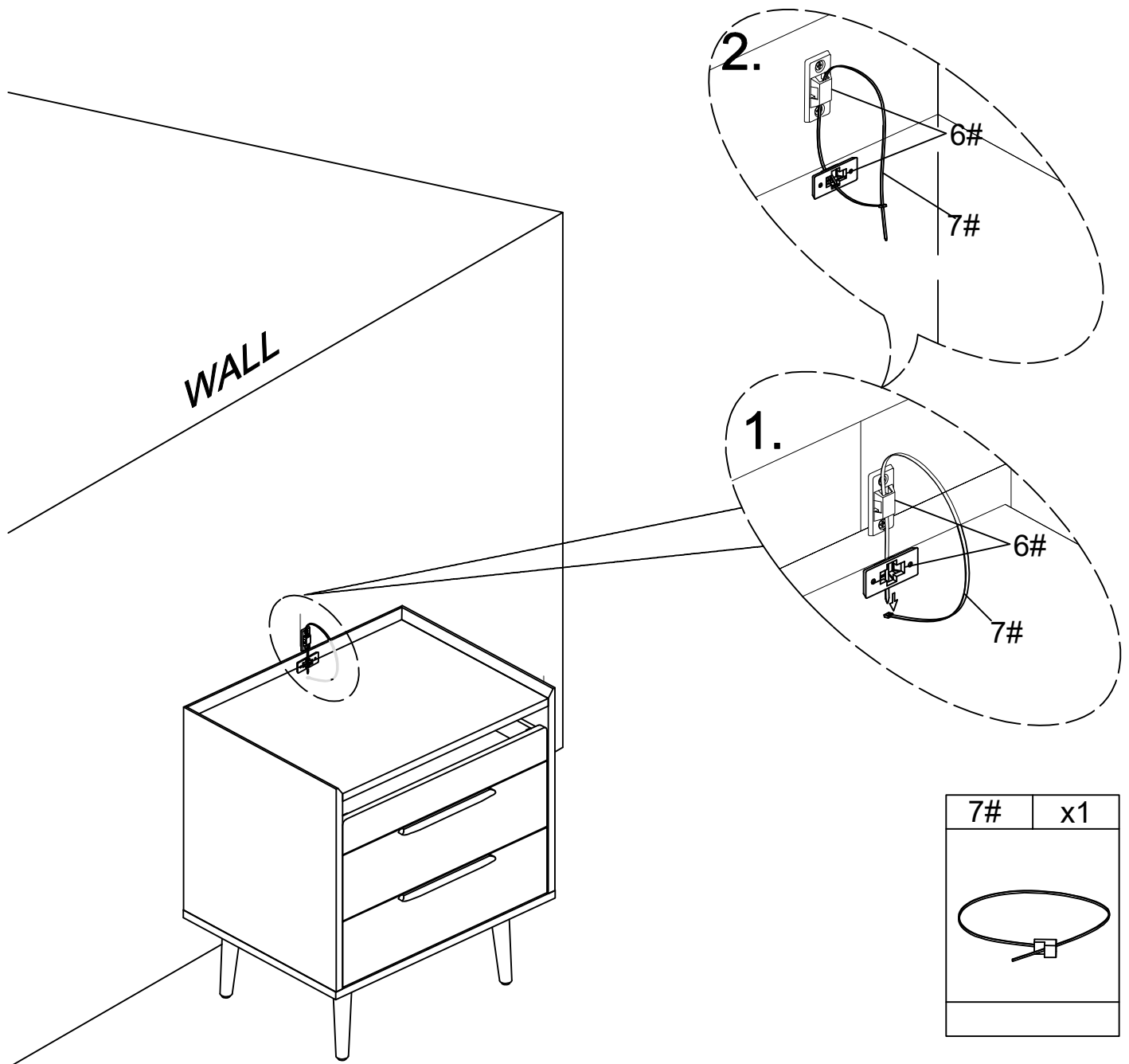

# WARRANTY

1. We strive to offer high-quality products, and we also try our best to satisfy each and every customer that orders from us with product or service as needed.
2. We provide 30 days warranty starting from the time you receive the item. Each customer must provide a record of their order such as the order number, or item receipt for any items that are out of the warranty period you may also still receive.
3. Replacement parts by purchasing them with our company if they are available.