

LED DOUBLE RING FLUSH MOUNT CEILING LIGHT



Application: Ideal for residential place, office, hallways, utility room and commercial place such as hotel rooms.

Certifications



Product Description

LED Double ring ceiling flush mount ceiling light is an ideal low maintenance, high efficiency light option for different places in a more stylish way.

SPECIFICATIONS:

Wattage	16W	22W	26W
Size	12"	14"	16"
Lumens	1450 LM	1850 LM	2200 LM
Rated Input Voltage(V)	AC 120V		
Light Source	SMD		
CCT	CCT Selectable: 2700K/3000K/3500K/4000K/5000K		
Body	Stainless Steel		
Beam Angle (°)	110°		
Dimming	YES		
Lumen Efficiency	80~85 Lm/W		
Color Rendering Index	Ra>80		
Power Factor	0.95		
Working Temperature	-4 ° F ~+105 °F / -15°C ~40°C		
Storage Temperature	-4 ° F ~+105° F / -15 ° C ~ +40 ° C		
Environment Location	IP 20 – Indoor Only		
Lifespan	Lumen Maintenance over 70% @ 50,000+ Hours		
Body Finish	Brushed Nickel		
Certificate	Energy Star/ ETL		
Package Info	18.5"X13.0"X13.2"	19.9"X14.8"X15.0"	23.3"X16.7"X16.5"
PC/ Master Pack	6	6	6
Weight	5.99 kg/13.2 lbs	8.1 kg/17.9 lbs	10.03 kg/22.1 lbs

FEATURE

- WARRANTY--5-year limited warranty
- 10%-100% Dimmable
- Damp Location
- Durable polymer cover

STRUCTURE

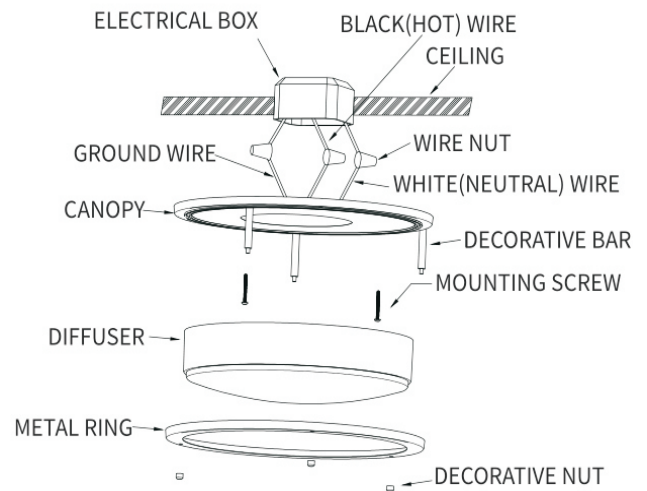

ORDERING CODE DEFINITION

EXAMPLE: HY -DR12-16WCCT

Company Code	Product	Size	Power:	CCT
HY	DR: Double Ring Flush Mount Ceiling Light	12"	16W	5 CCT Selectable: 2700K/3500K/4000K/5000K/6500K
		14"	22W	
		16"	26W	

PRODUCT DIMENSION

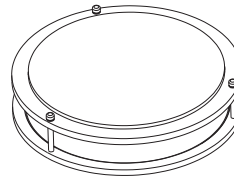
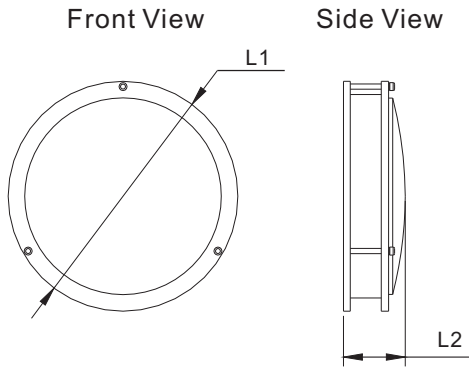

L1	Φ305mm/Φ12"	Φ355mm/Φ14"	Φ405mm/Φ16"
L2	65mm/2.56"	75mm/2.95"	85mm/3.35"

INSTALLATION GUIDE

1 CCT Adjustable

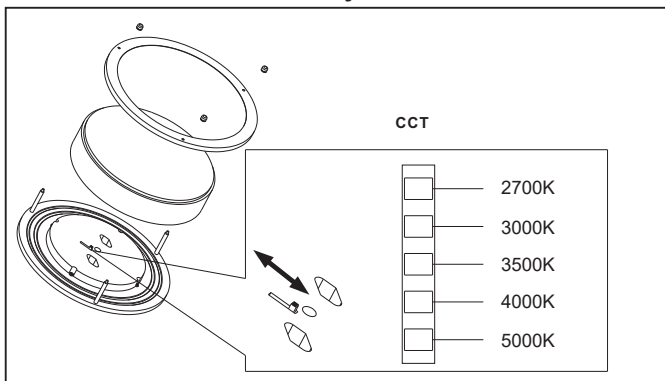

2 Wiring Guide

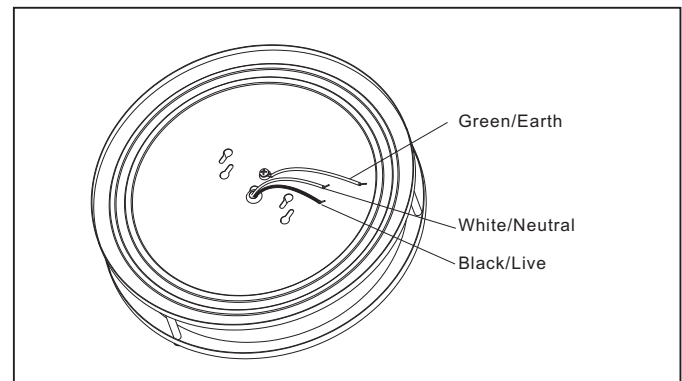

PHOTOMETRIC REPORT

