

Kids Kitchen Playset  
Jeu de Cuisine pour Enfants

THIS INSTRUCTION BOOKLET CONTAINS **IMPORTANT** SAFETY INFORMATION.  
PLEASE READ AND KEEP FOR FUTURE REFERENCE.



## Before You Start

Please read all instructions carefully and keep it for future reference.

### General Security Warning

**Caution:** Children should use this product under the parental supervision.

**Danger:** Keep all small parts and packaging materials for this product away from babies and children, otherwise they may pose a choking hazard.

**Danger:** Lack of attachment may cause a risk of tipping.



**WARNING:  
CHOKING HAZARD**  
-Small parts.  
Not for children under 3 years.

### Warning for Assembly

- ⚠ Assembled only by adults
- ⚠ Remove all packaging, separate and count all parts and hardware.
- ⚠ Read through each step carefully and follow the proper order.
- ⚠ We recommend that, where possible, all items are assembled near the area in which they will be placed in use, to avoid moving the product unnecessarily once assembled.
- ⚠ Ensure a secure surface during installation, and always place the product on a flat, steady and stable surface.



## Avant de Commencer

Veuillez lire attentivement toutes les instructions et les conserver pour la référence ultérieure.

### Avertissement de Sécurité Générale

**Attention :** Les enfants doivent utiliser ce produit sous la surveillance de leurs parents.

**Danger :** Gardez toutes les petites pièces et les matériaux d'emballage de ce produit hors de la portée des bébés et des enfants pour éviter un risque d'étouffement.

**Danger :** Le manque de la fixation pourrait entraîner un risque de basculement.



**AVERTISSEMENT :  
RISQUE D'ÉTOUFFEMENT**  
– Les petites pièces.  
Ne convient pas aux enfants de moins de 3 ans.

### Avertissement pour l'Assemblage

- ⚠ Construction seulement par des adultes
- ⚠ Retirez tous les emballages, séparez et comptez toutes les pièces et le matériel.
- ⚠ Lisez attentivement chaque étape et suivez l'ordre correct.
- ⚠ Nous recommandons que, dans la mesure du possible, tous les articles soient assemblés à proximité de la zone dans laquelle ils seront utilisés, afin d'éviter de déplacer inutilement le produit une fois assemblé.
- ⚠ Assurez-vous que la surface soit solide pendant la construction et placez toujours le produit sur une surface plane et stable.

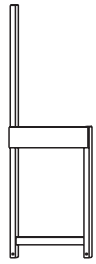

① x1

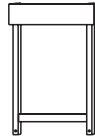

② x1

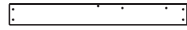

③ x1

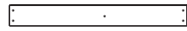

④ x1

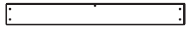

⑤ x1



⑥ x2



⑦ x2



⑧ x2



⑨ x2

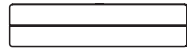

⑩ x1

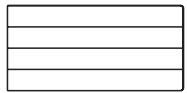

⑪ x1

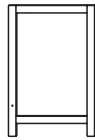

⑫ x1

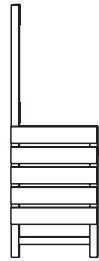

⑬ x1

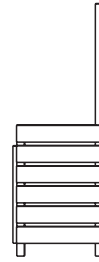

⑭ x1

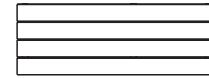

⑮ x1



⑯ x1

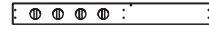

⑰ x1

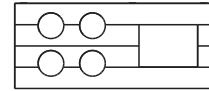

⑱ x1

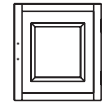

⑲ x1

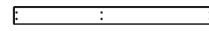

⑳ x1



㉑ x2

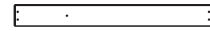

㉒ x1



㉓ x1

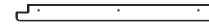

㉔ x1

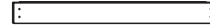

㉕ x1



㉖ x1



㉗ x1



㉘ x1



㉙ x1



30 x1



31 x1

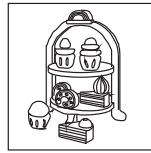

32 x1



3.5\*30

A x60



3.5\*35

B x22



3.0\*16

C x4



3.5\*45

D x4



6.0\*55

E x4



6.0\*45

F x8



3.0\*28

G x1



H x1

1

EN: Connect the parts 1, 2, 3 and 4 as shown.

FR: Connectez les pièces 1, 2, 3 et 4 comme indiqué.

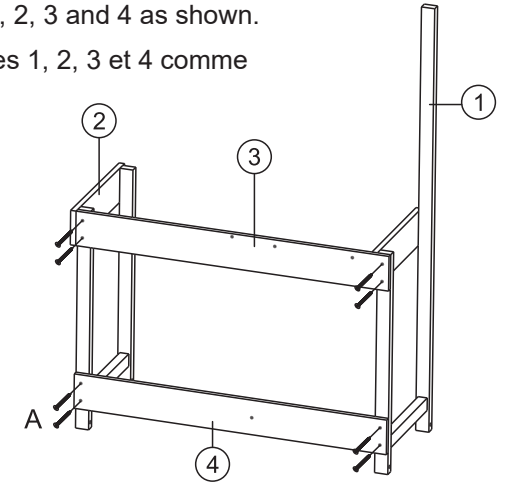

A\*8

2

EN: Install the back panel 5.

FR: Installez le panneau arrière 5.

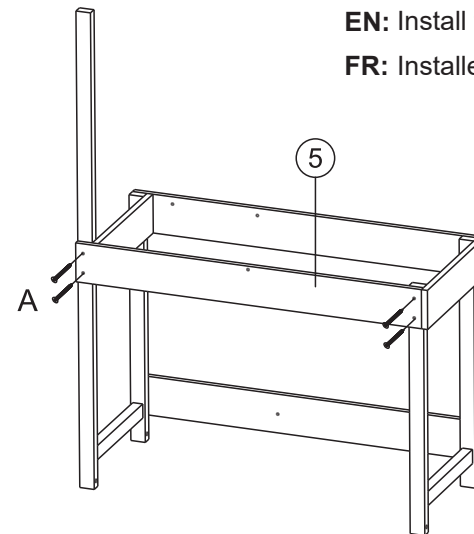

A\*4

3

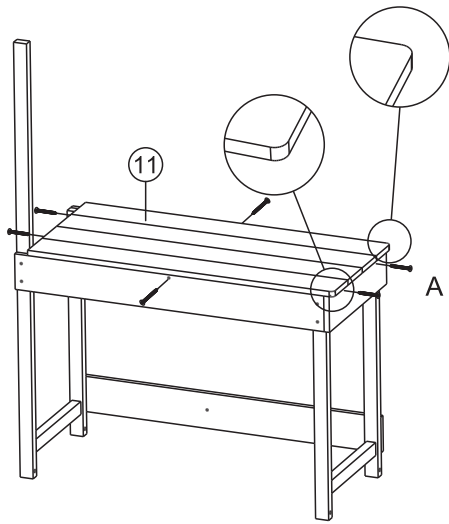

A\*6

**EN:** Install the desktop 11.  
**FR:** Installez le bureau 11.

4

**EN:** Connect the parts 6, 7, 8 and 10 as shown.  
**FR:** Connectez les pièces 6, 7, 8 et 10 comme indiqué.

F\*8

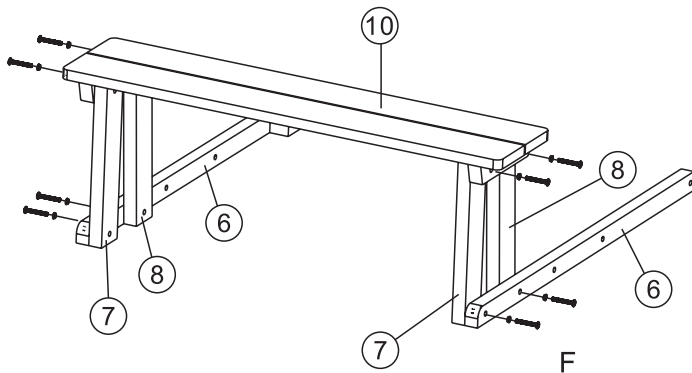

5

**EN:** Install the support frames 9.  
**FR:** Installez les cadres de support 9.

B\*4

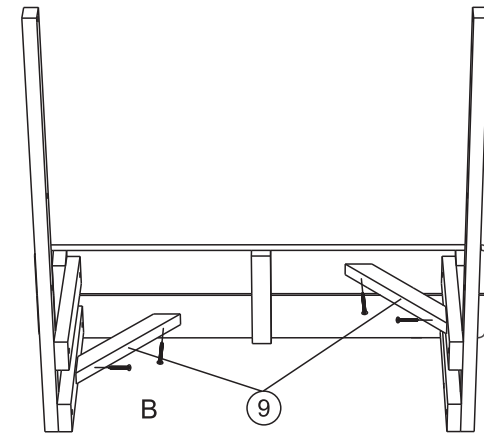

6

**EN:** Connect the bottom bars 6 to the table legs.  
**FR:** Connectez les barres inférieures 6 aux pieds de la table.

E\*4

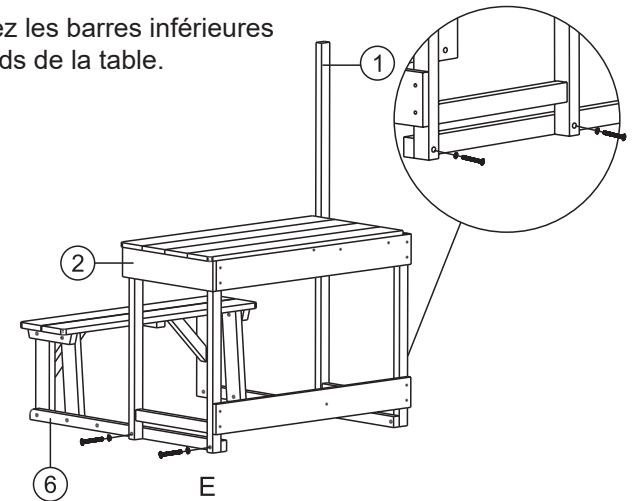

7

**EN:** Connect the bottom panel 15 to the frames 12, 13 and 14.

**FR:** Connectez le panneau inférieur 15 aux cadres 12, 13 et 14.

B\*4

D\*2

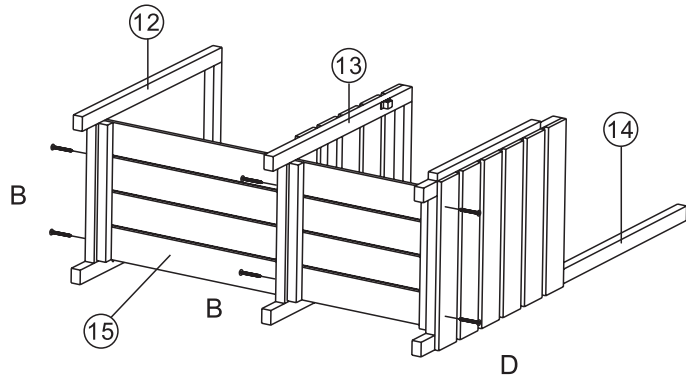

8

**EN:** Install the middle plate 16.

**FR:** Installez la plaque centrale 16.

H\*1

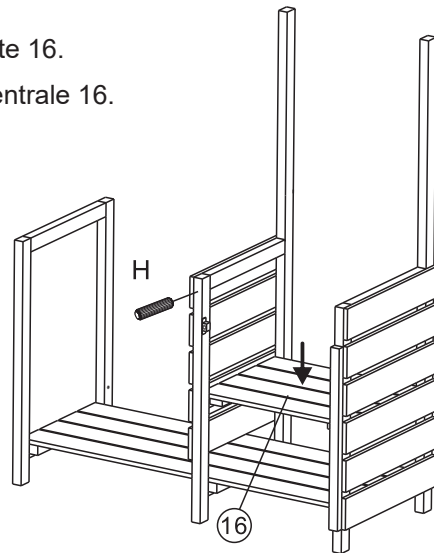

9

**EN:** Install the front panel 17.

**FR:** Installez le panneau avant 17.

B\*6

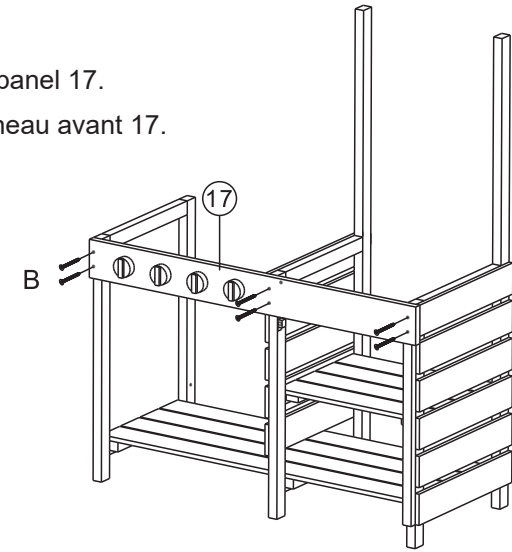

10

**EN:** Install the rungs 21.

**FR:** Installez les barreaux 21.

A\*4

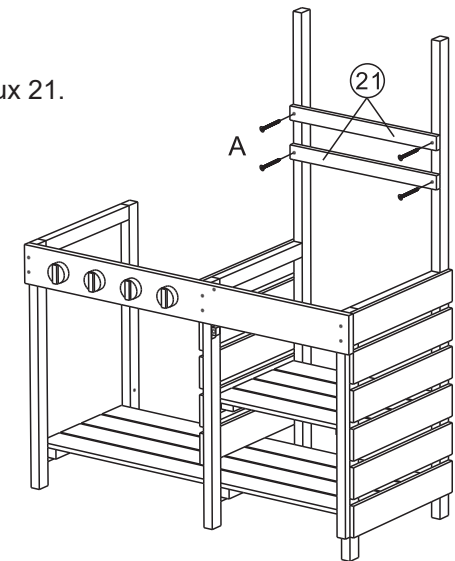

11

EN: Install the countertop 18.  
FR: Installez le plan de travail 18.

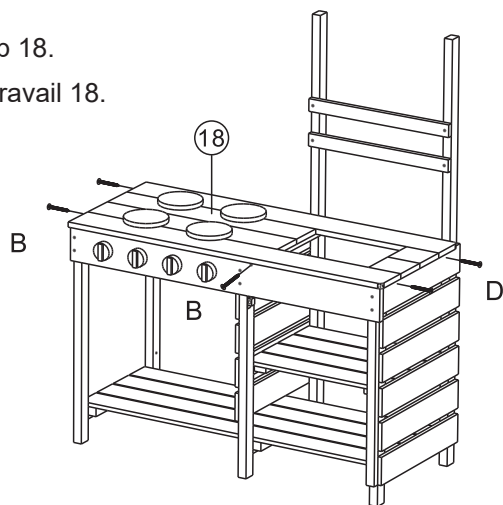

B*3
D*2

13

EN: Install the back panels 20.  
FR: Installez les panneaux arrière 20.

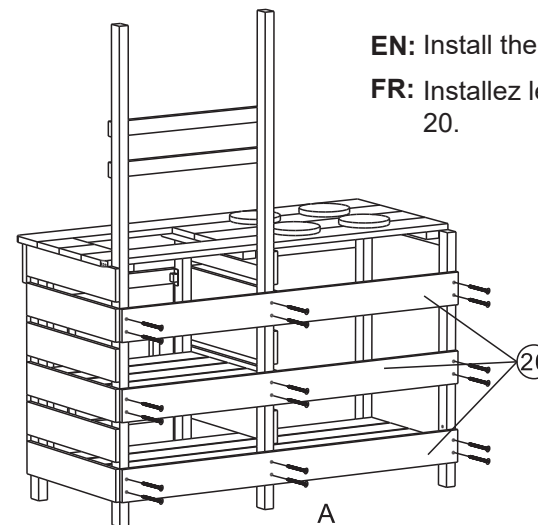

A\*18

12

EN: Install the door 19 and handle 28.  
FR: Installez la porte 19 et la poignée 28.

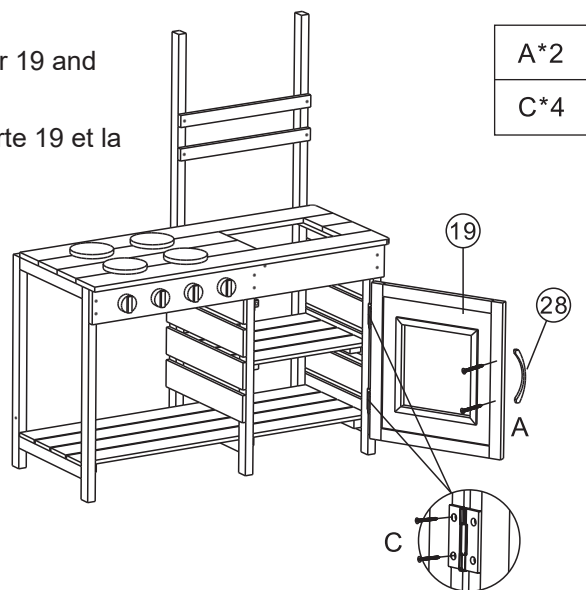

A*2
C*4

14

EN: Connect the assembled combinations as shown.  
FR: Connectez les combinaisons assemblées comme indiqué.

B\*1

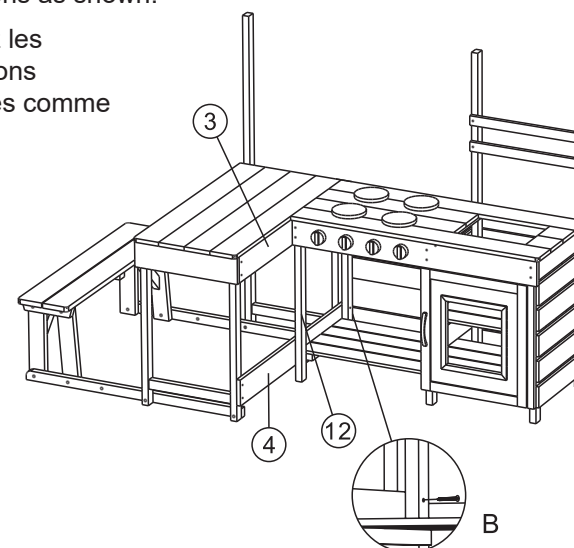

15

EN: Connect the assembled combinations as shown.

FR: Connectez les combinaisons assemblées comme indiqué.

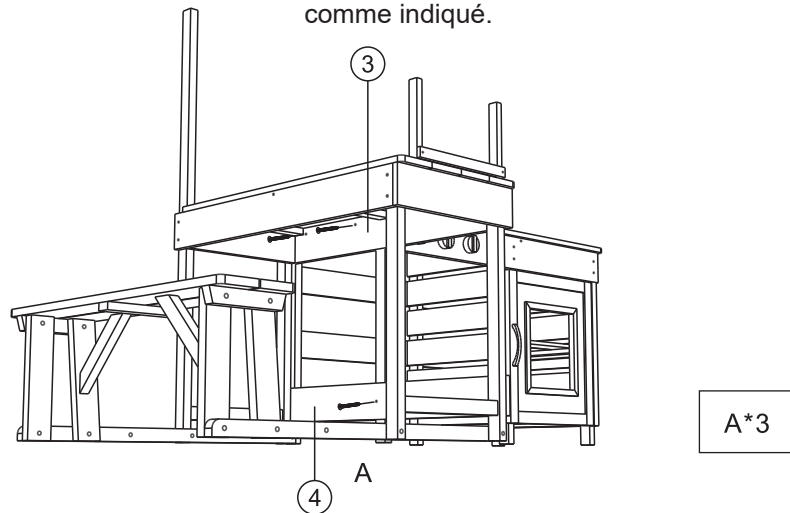

16

EN: Install the guardrails 25 and 26.

FR: Installez les garde-corps 25 et 26.

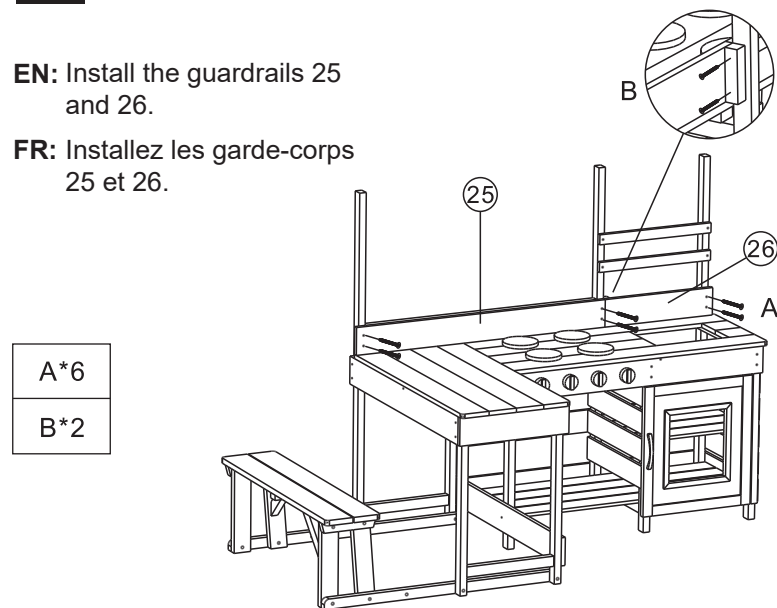

17

EN: Install the top bars 22 and 23.

FR: Installez les barres supérieures 22 et 23.

A*6
B*2

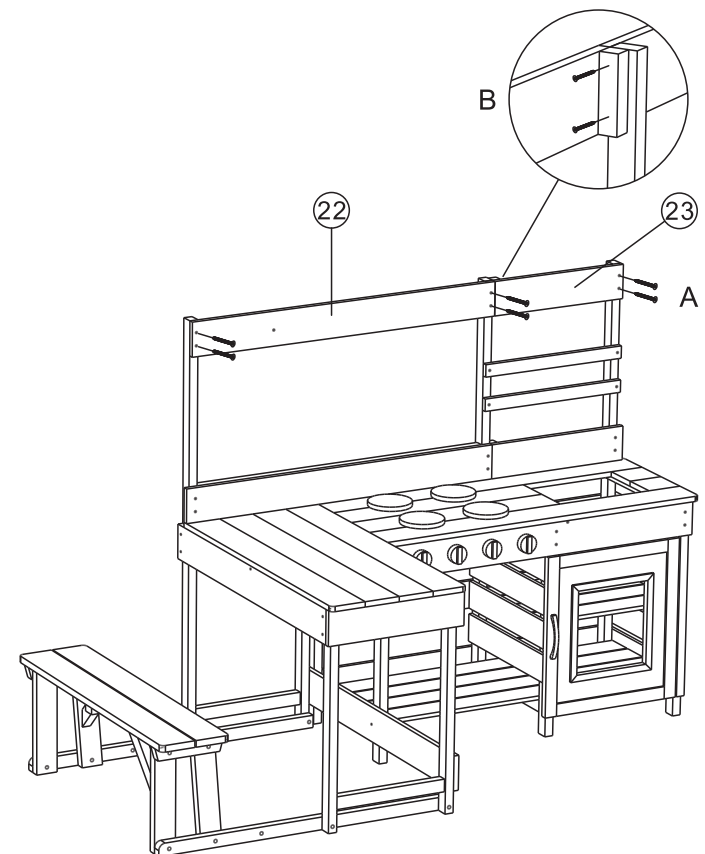

18

EN: Install the hook 29 and shelf 24.

FR: Installez le crochet 29 et l'étagère 24.

A*3
G*1

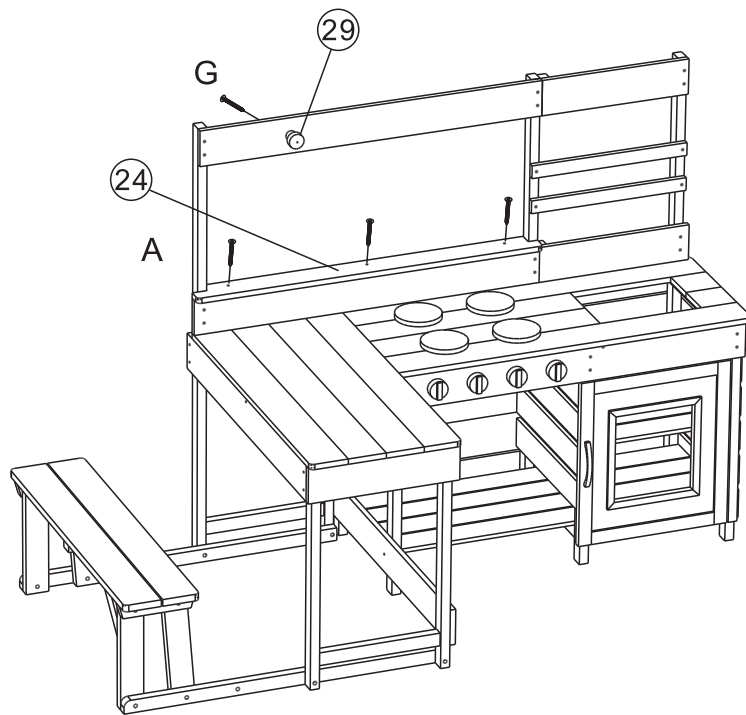

19

EN: Add the accessories 27, 30 and 31.

FR: Ajoutez les accessoires 27, 30 et 31.

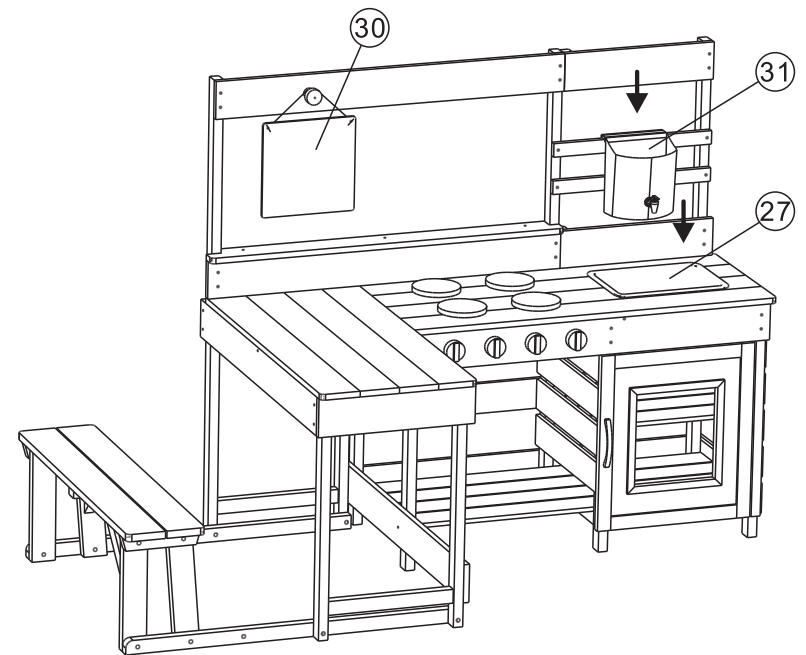

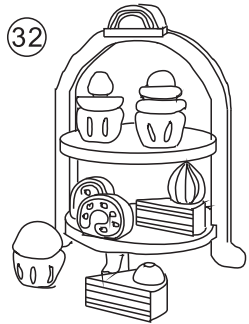

**EN:** Add the set 32.

**FR:** Ajoutez le kit 32.

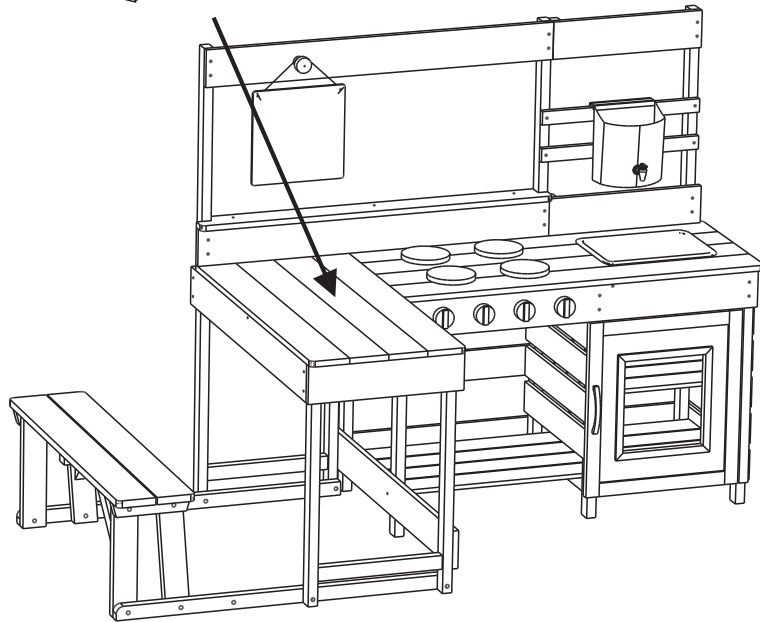

EN



### Return / Damage Claim Instructions

- ⚠ **DO NOT discard the box / original packaging.**  
In case a return is required, the item must be returned in original box. Without this your return will not be accepted.
- ⚠ **Take a photo of the box markings.**  
A photo of the markings (text) on the side of the box is required in case a part is needed for replacement. This helps our staff identify your product number to ensure you receive the correct parts.
- ⚠ **Take a photo of the damaged part (if applicable).**  
A photo of the damage is always required to file a claim and get your replacement or refund processed quickly. Please make sure you have the box even if it is damaged.
- ⚠ **Send us an email with the images requested.**  
Email us directly from marketplace where your item was purchased with the attached images and a description of your claim.

FR



### Instructions De Retour / Réclamation De Dommages

- ⚠ **NE PAS jeter la boîte/l'emballage d'origine.**  
Dans le cas où un retour est requis, l'article doit être retourné dans sa boîte d'origine. Sans cela, votre retour ne sera pas accepté.
- ⚠ **Prenez une photo des marquages de la boîte.**  
Une photo des marquages (texte) sur le côté de la boîte est requise au cas où une pièce serait nécessaire pour le remplacement. Cela aide notre personnel à identifier votre numéro de produit pour s'assurer que vous recevez les bonnes pièces.
- ⚠ **Prenez une photo des dommages (le cas échéant).**  
Une photo des dommages est toujours requise pour déposer une réclamation et obtenir rapidement votre remplacement ou votre remboursement. Assurez-vous d'avoir la boîte même si elle est endommagée.
- ⚠ **Envoyez-nous un e-mail avec les images demandées.**  
Envoyez-nous un e-mail directement depuis le marché où votre article a été acheté avec les images ci-jointes et une description de votre réclamation.