

Assembly Instruction

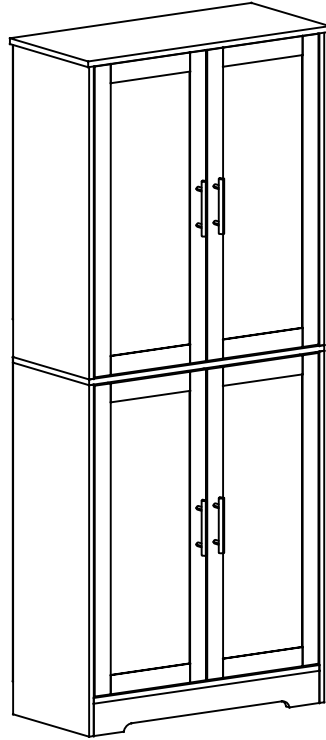

Trouble shooting:

Missing / Wrong / Broken parts and installation issues



Send email with your question pie ,order NO. and screenshot of order details to.



Respond within 24 hours



Issue resolved

COMPONENTS ID Nr.

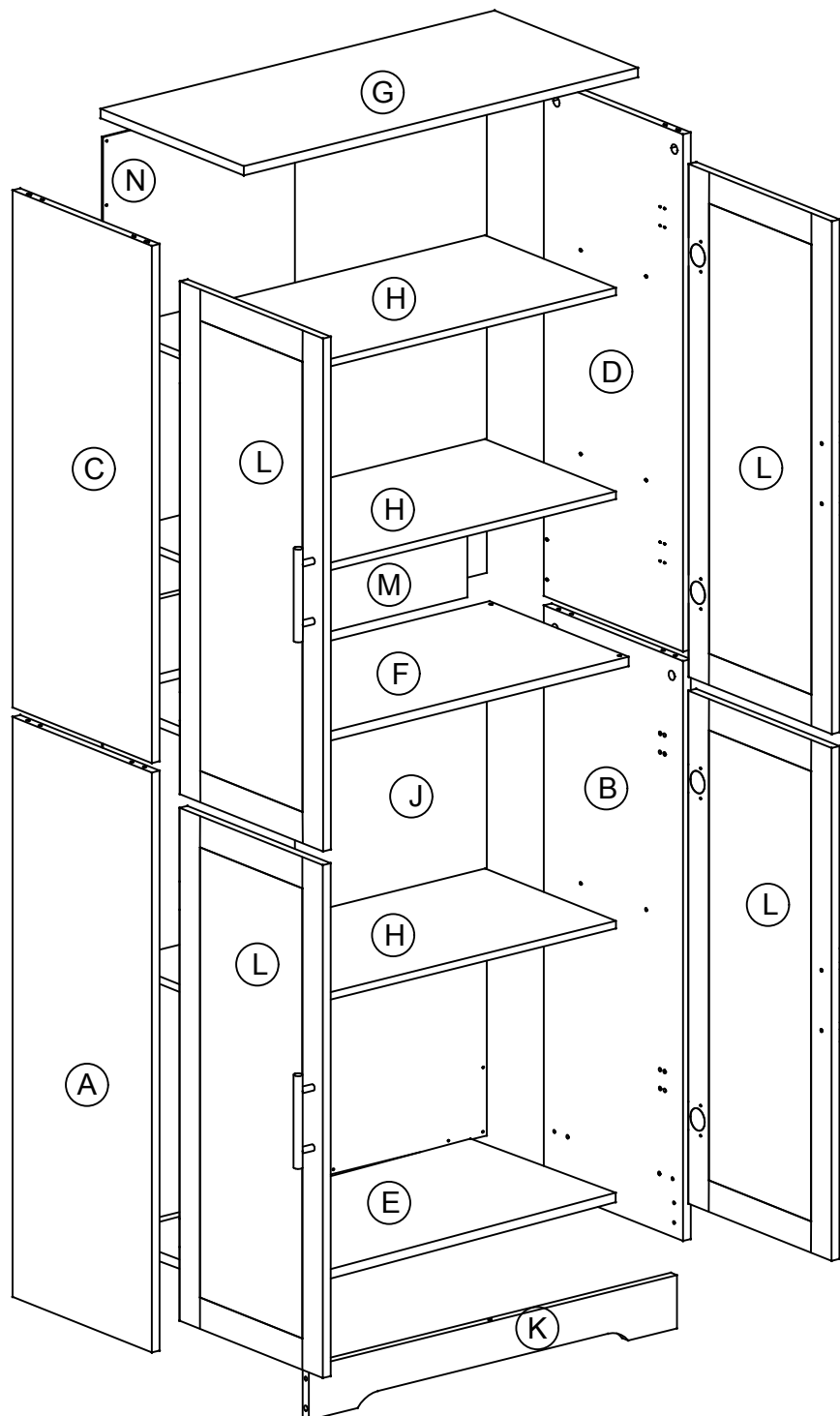

Part Nr.	Qty	Part Nr.	Qty	Part Nr.	Qty
A	1pcs	B	1pcs	C	1pcs
D	1pcs	E	1pcs	F	1pcs
G	1pcs	H	3pcs	J	1pcs
K	1pcs	L	4pcs	M	1pcs
N	1pcs				

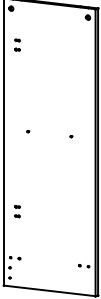
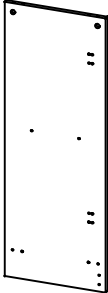
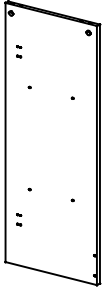
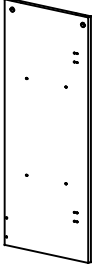
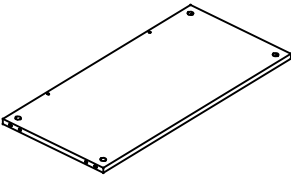
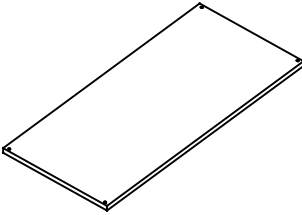
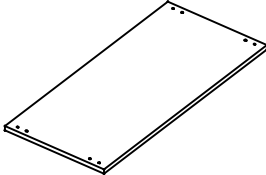
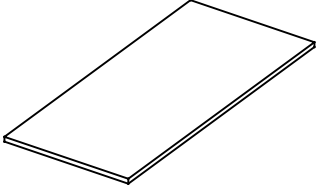
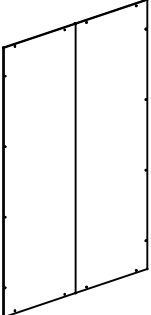
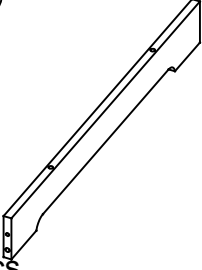
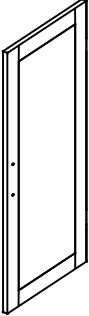
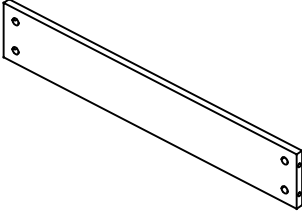
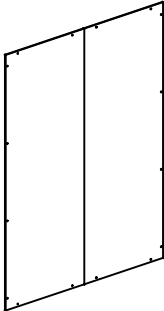

HARDWARE LIST

<p>(A)</p>  <p>1pcs</p>	<p>(B)</p>  <p>1pcs</p>	<p>(C)</p>  <p>1pcs</p>	<p>(D)</p>  <p>1pcs</p>
<p>(E)</p>  <p>1pcs</p>	<p>(F)</p>  <p>1pcs</p>	<p>(G)</p>  <p>1pcs</p>	<p>(H)</p>  <p>3pcs</p>
<p>(J)</p>  <p>1pcs</p>	<p>(K)</p>  <p>1pcs</p>	<p>(L)</p>  <p>4pcs</p>	<p>(M)</p>  <p>1pcs</p>
<p>(N)</p>  <p>1pcs</p>			

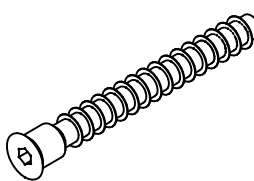
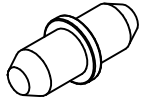
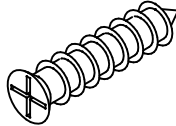
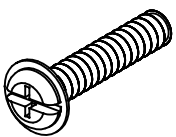
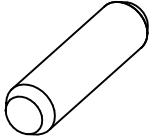
HARDWARE LIST

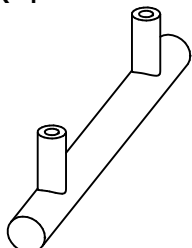
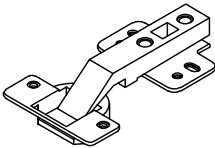
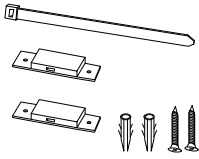
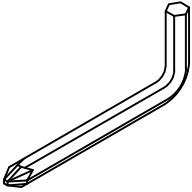
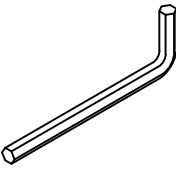
<p>① x 7</p>  <p>D5*40mm</p>	<p>② x 12</p>  <p></p>	<p>③ x 80</p>  <p>D3*12mm</p>	<p>④ x 8</p>  <p>M4X18mm</p>
<p>⑤ x 14</p>  <p>6X30mm</p>	<p>⑥ x 20</p>  <p></p>	<p>⑦ x 20</p>  <p></p>	<p>⑧ x 4</p>  <p></p>
<p>⑨ x 8</p>  <p></p>	<p>⑩ x 2</p>  <p></p>	<p>⑪ x 1</p>  <p>4#</p>	<p>⑫ x 1</p>  <p>3#</p>

1

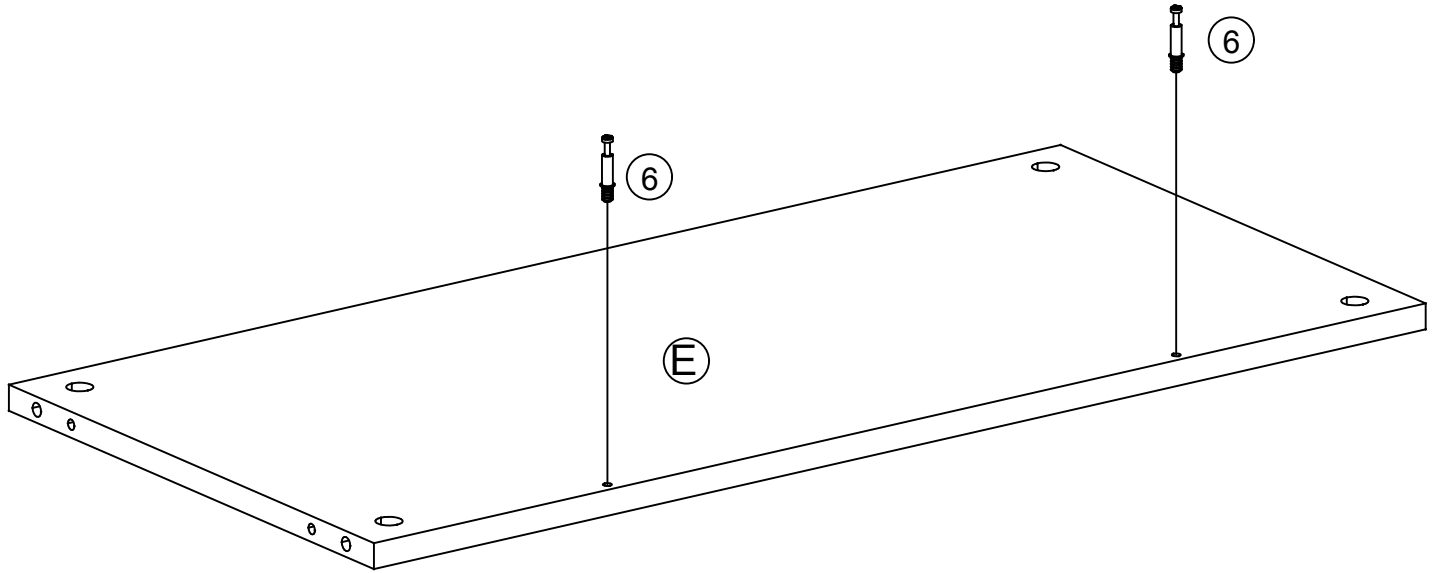

2

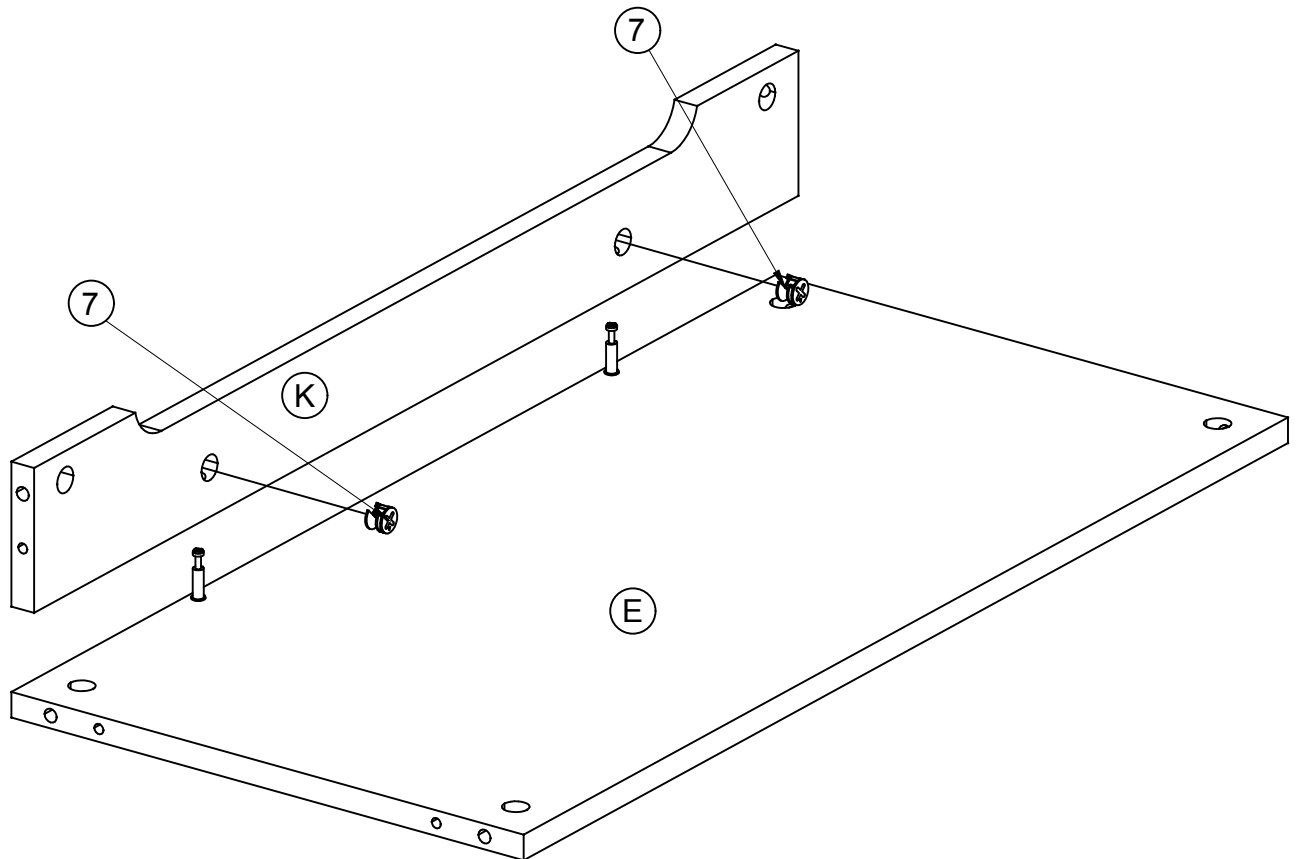

3

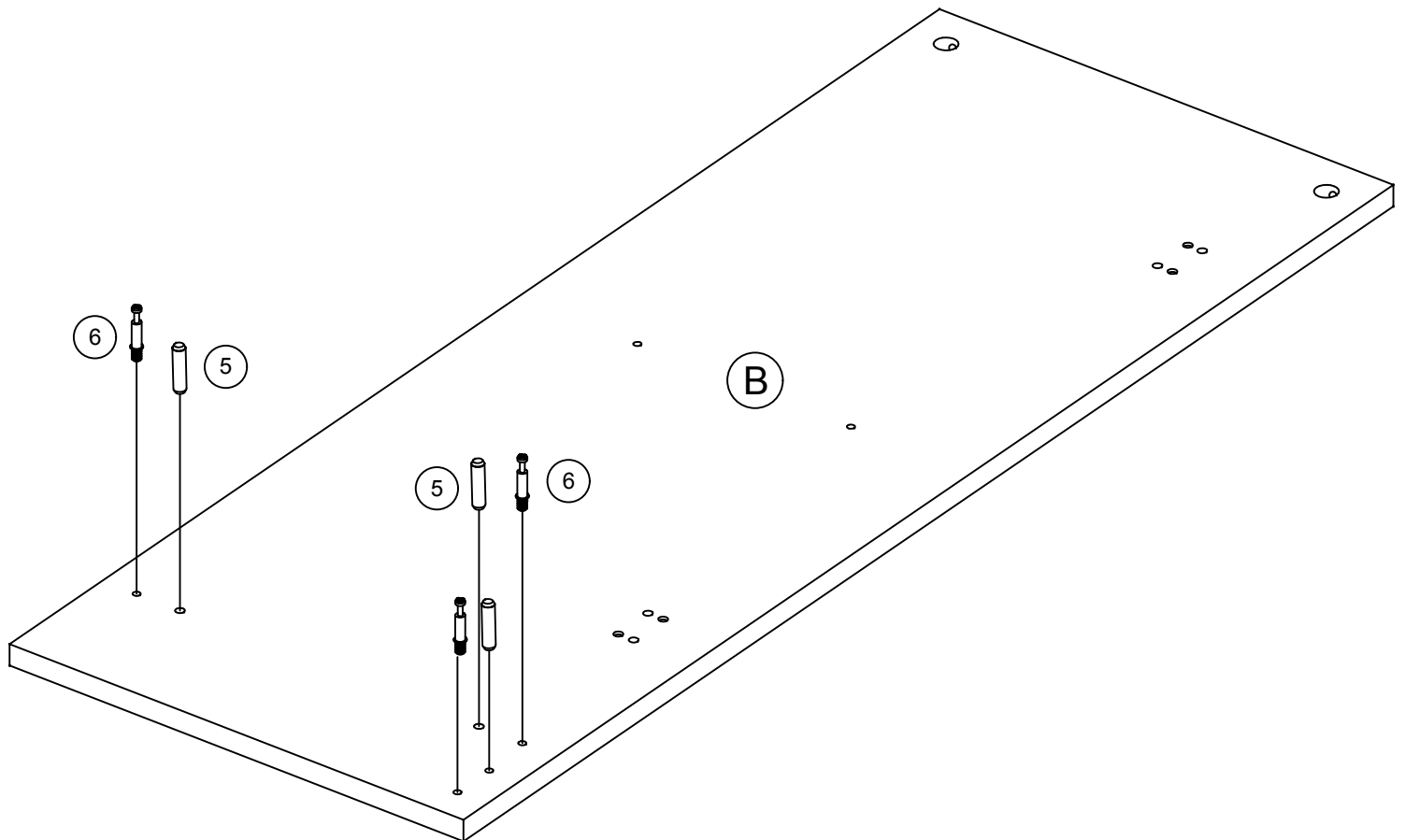
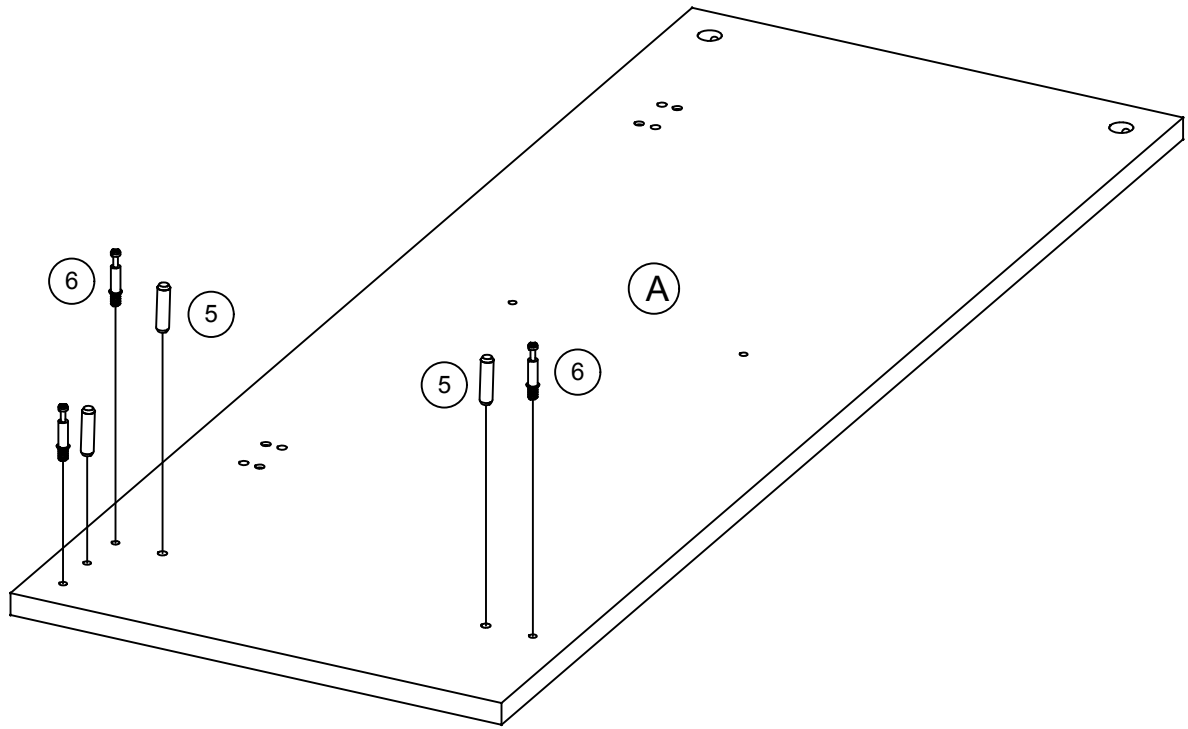

4

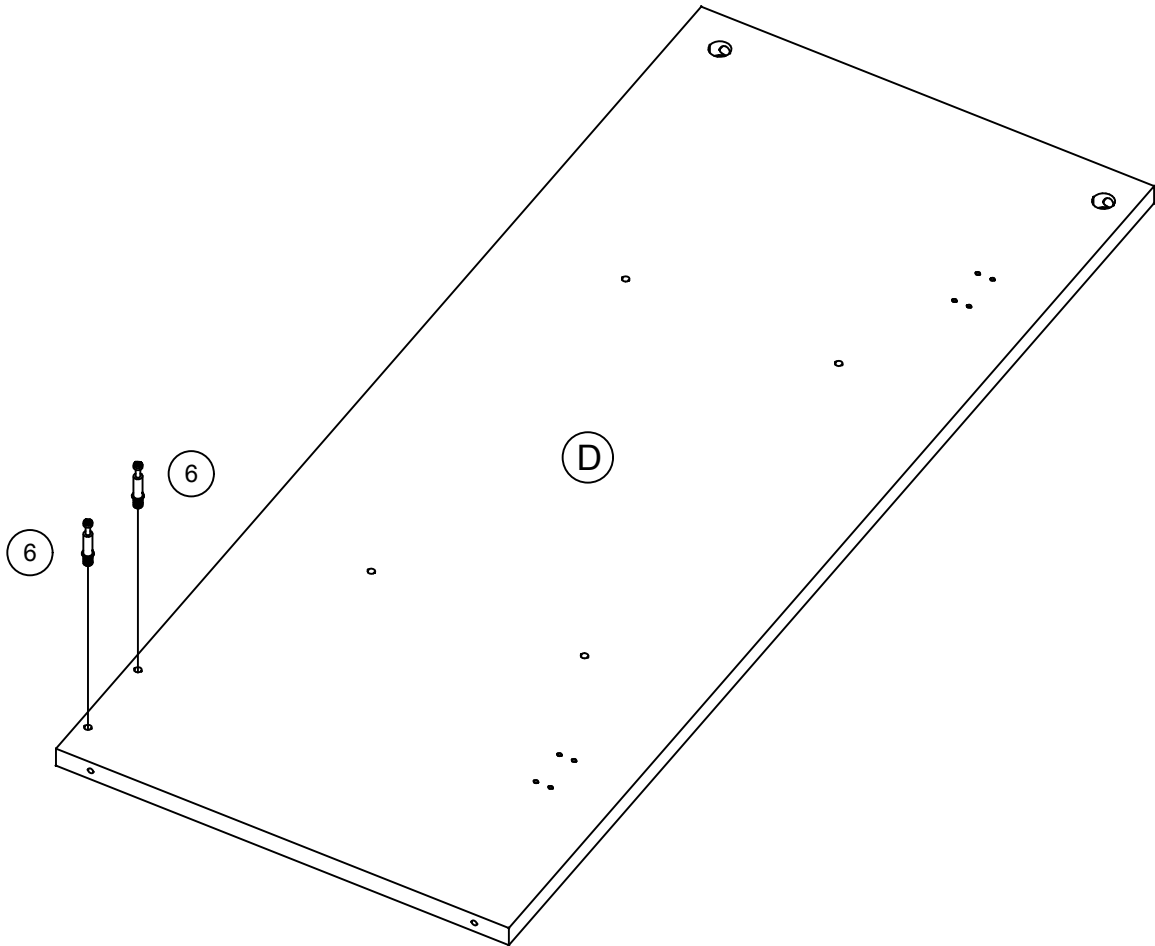
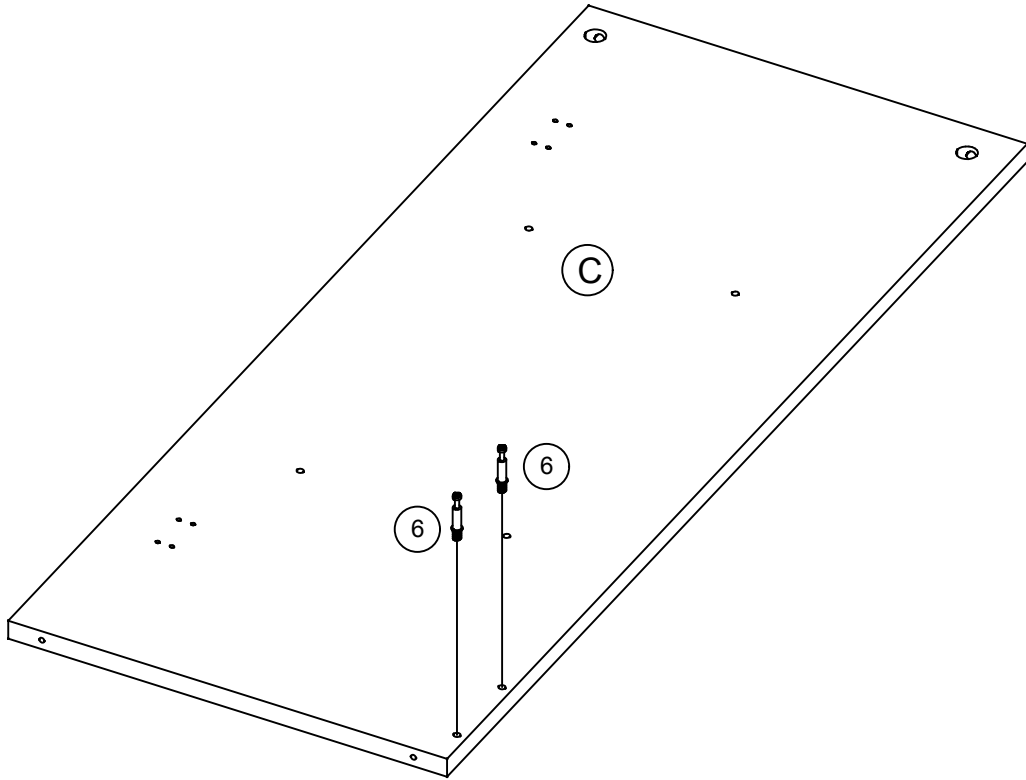

5

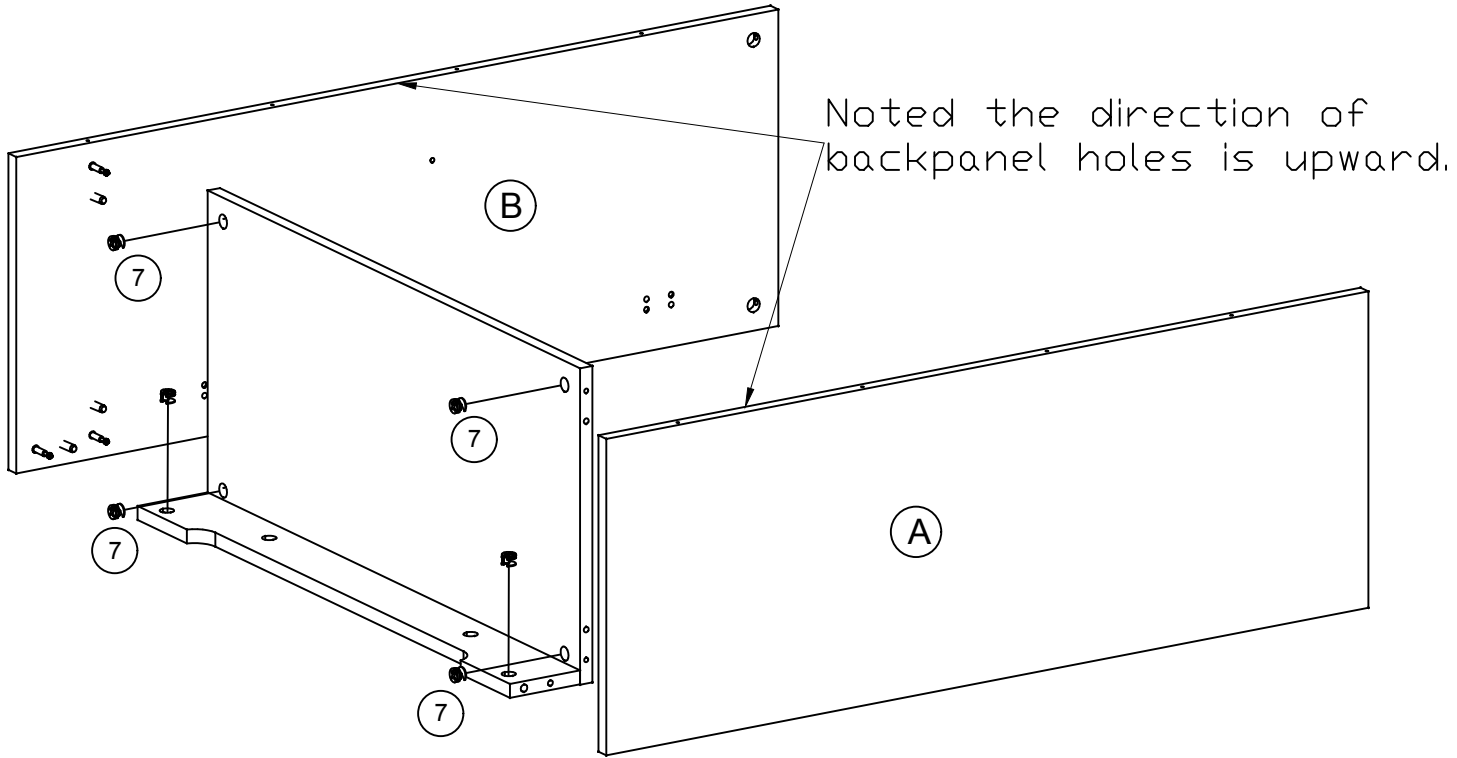

6

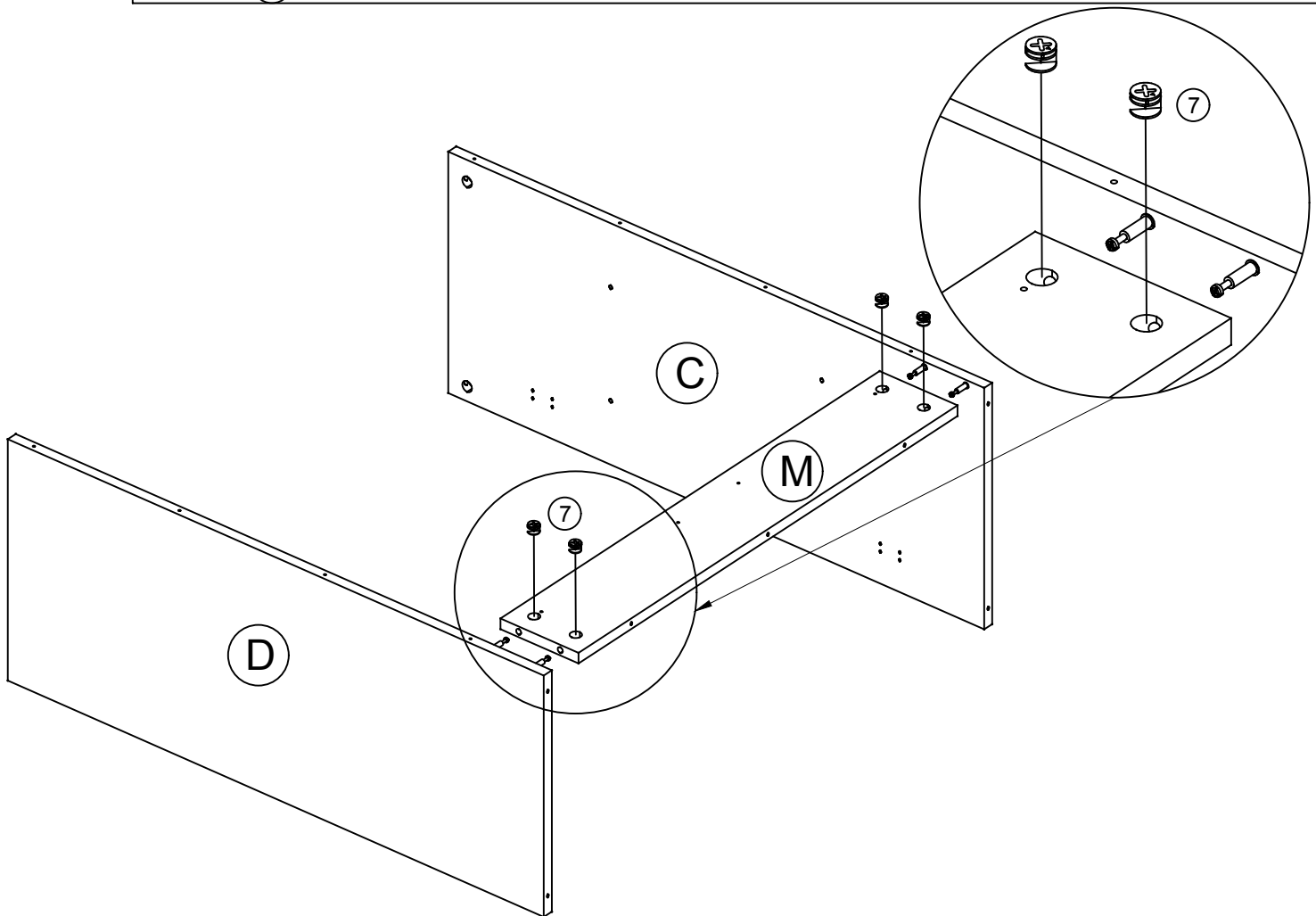

7

D5X40MM



① x 7

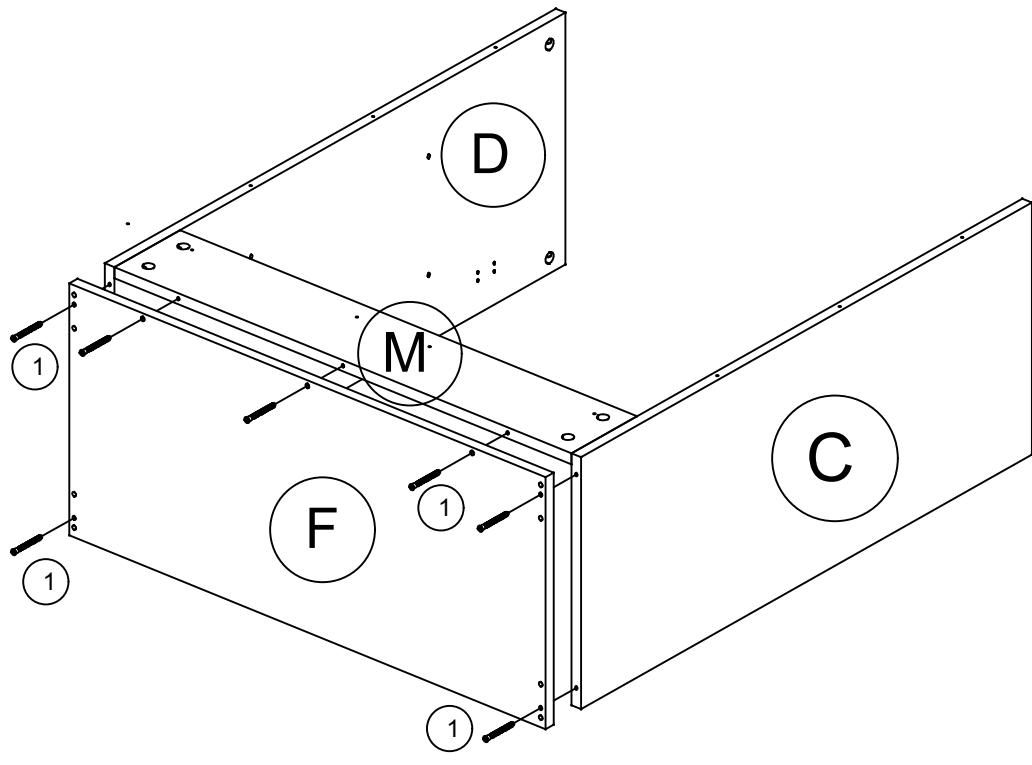

8



⑤ x 4



⑥ x 4

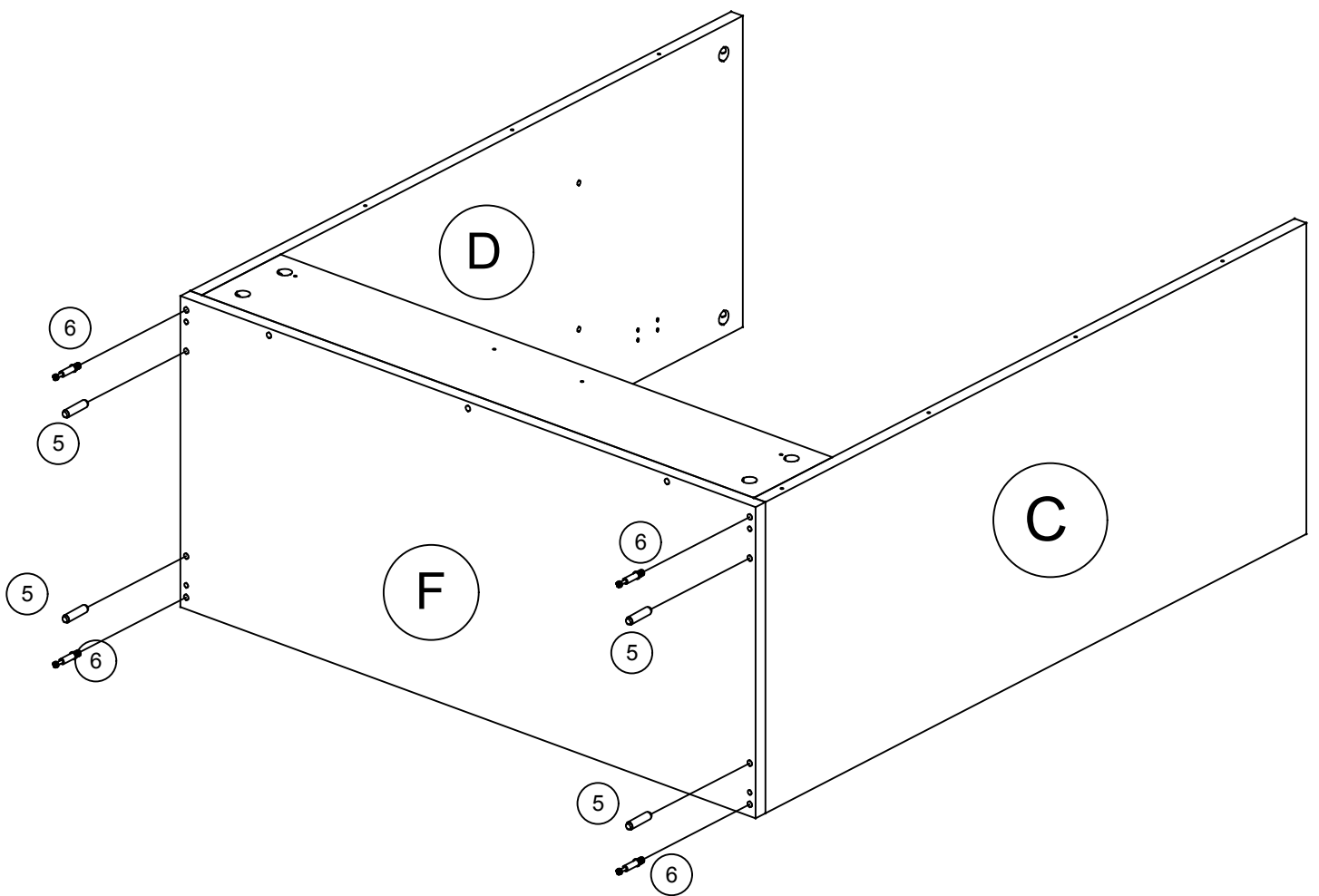

9

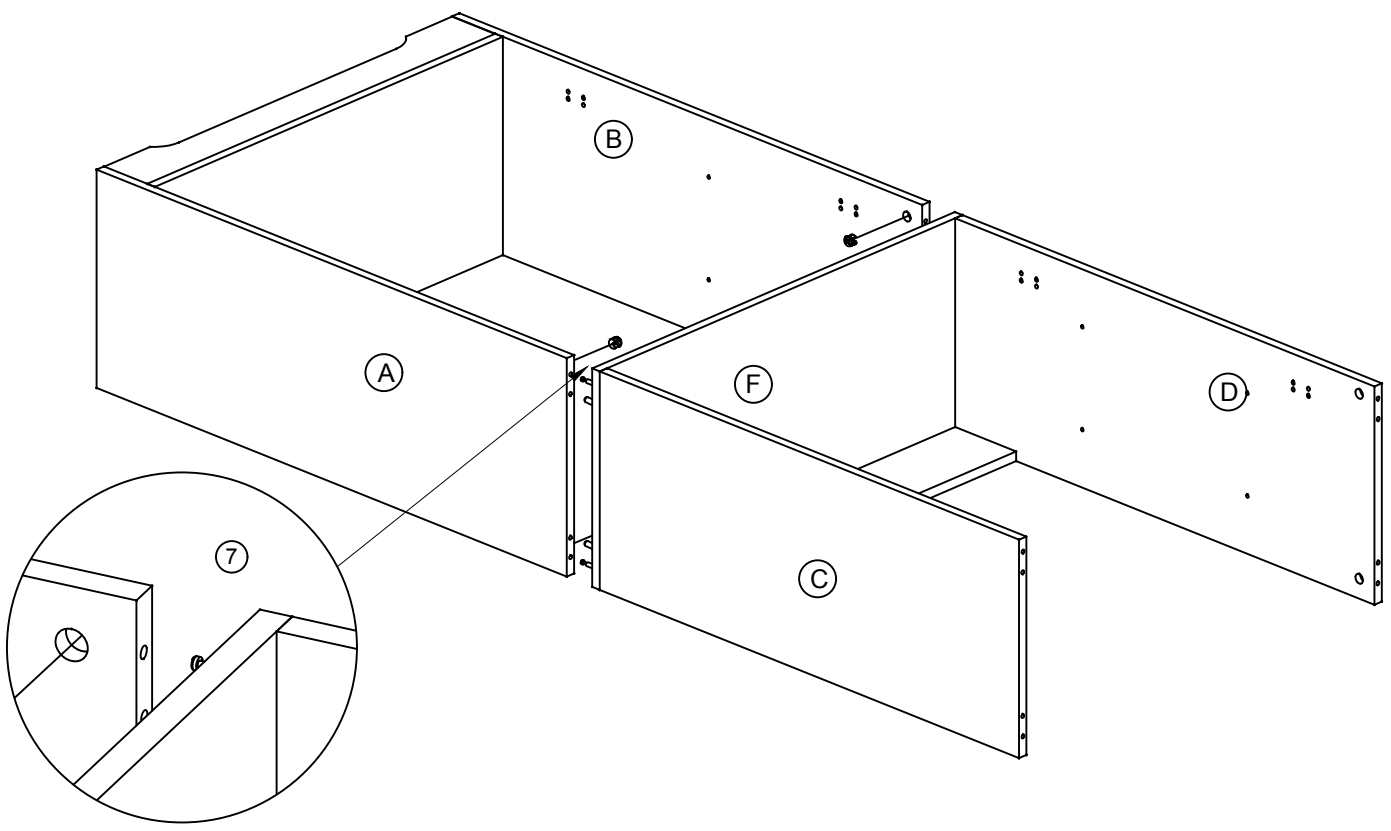

10

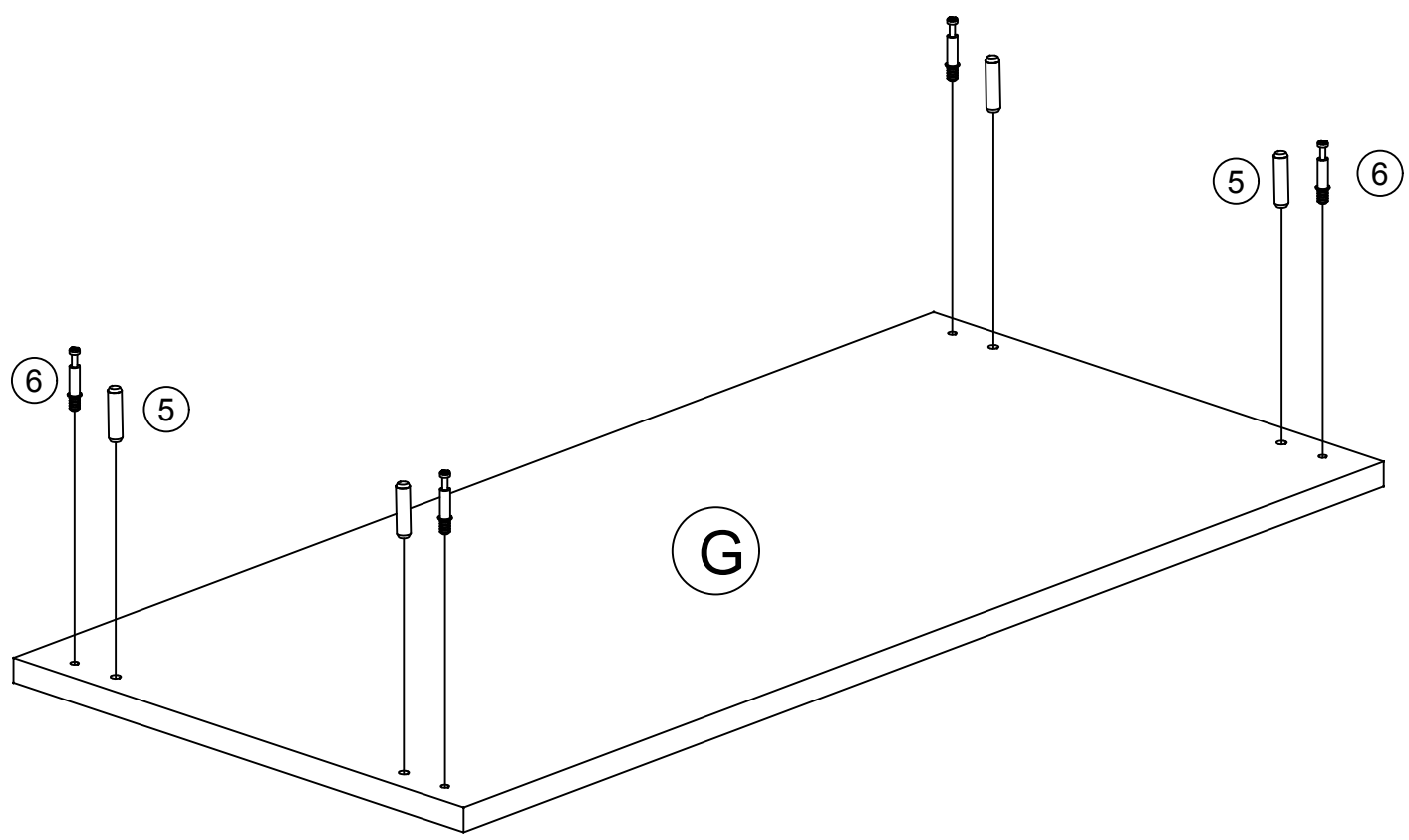
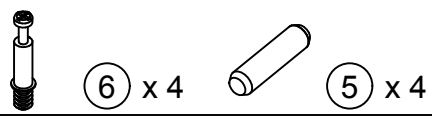

11

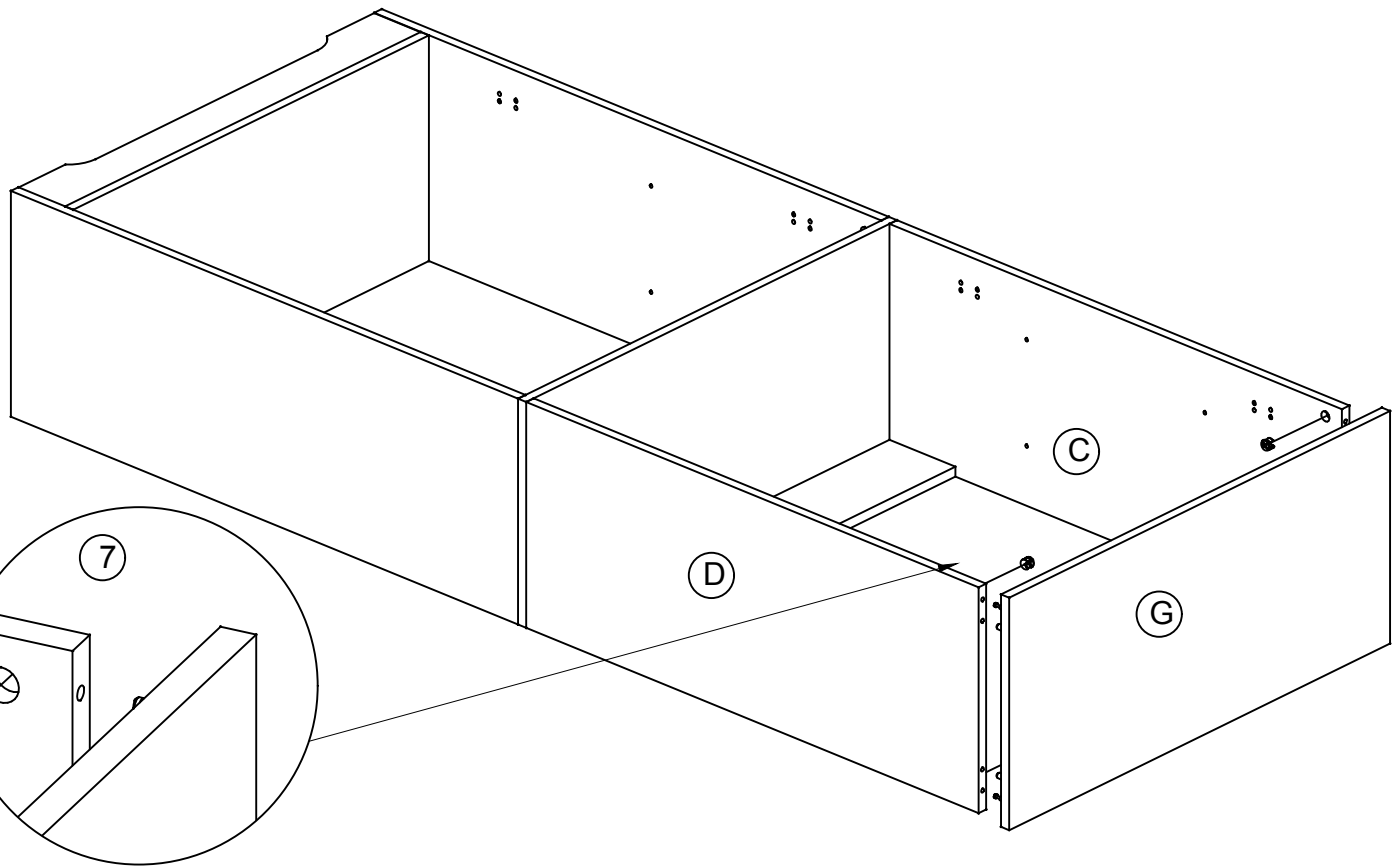

12

Pls careful to stand up the product.

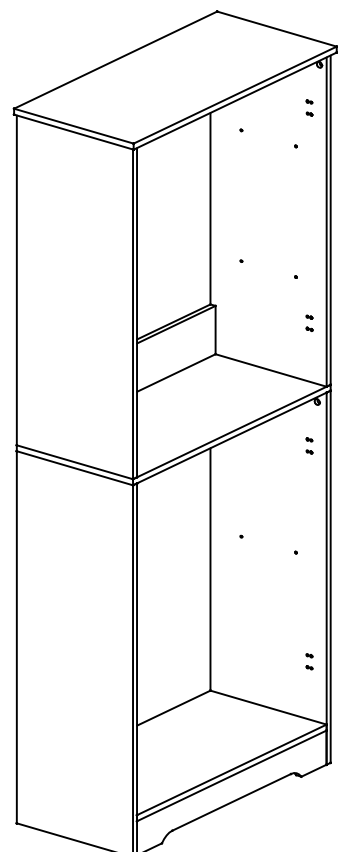
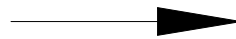
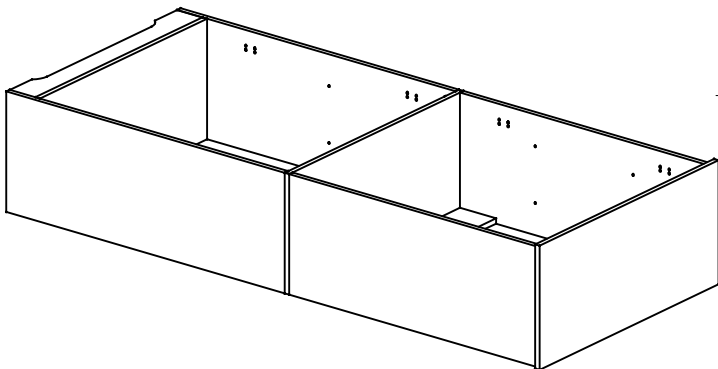

13



③ x 32

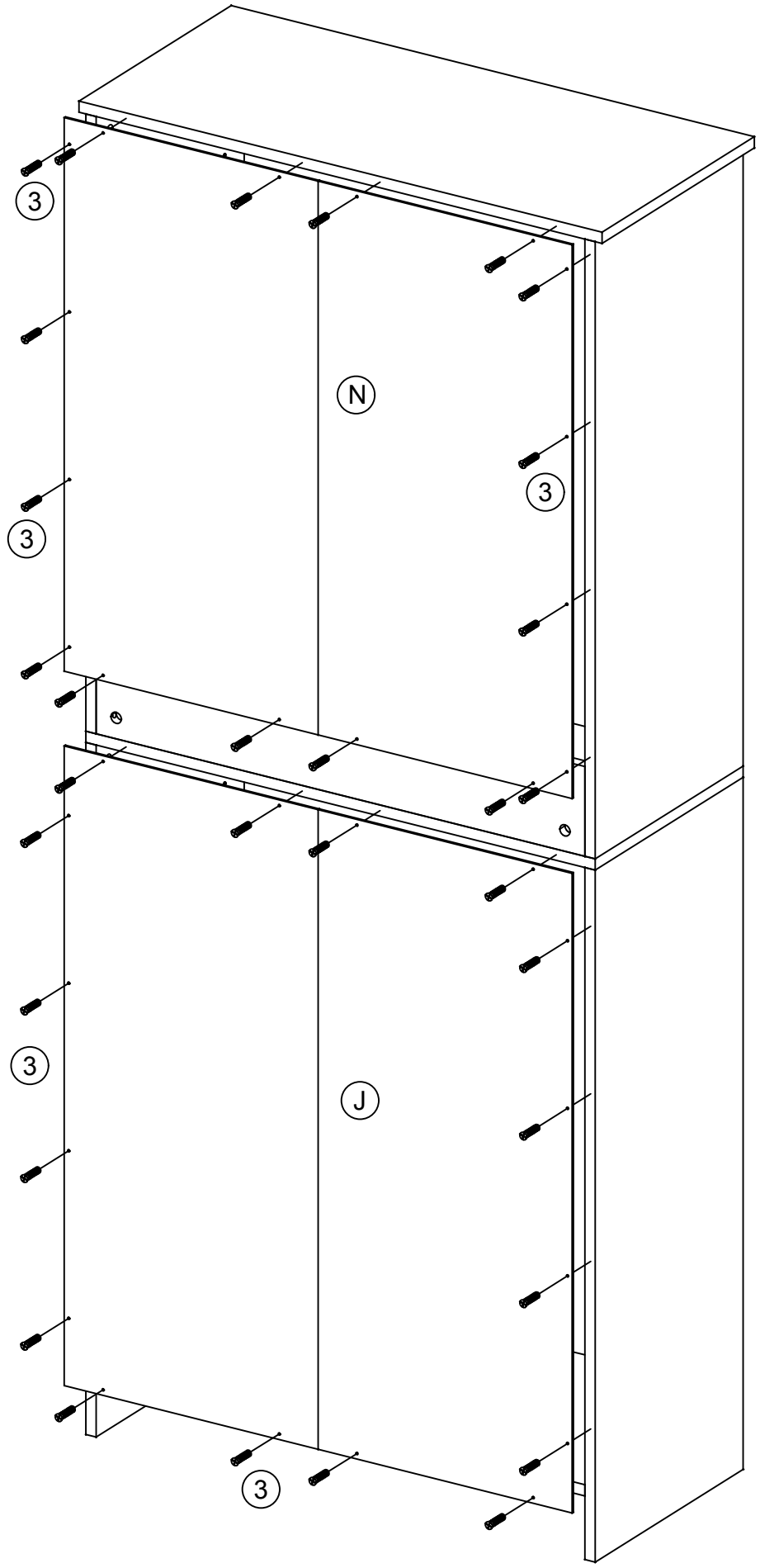

14

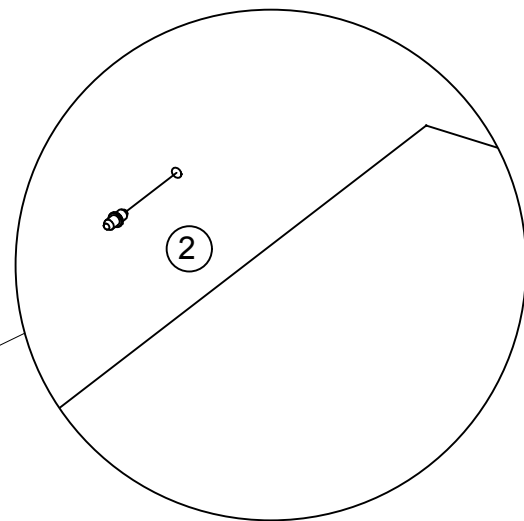
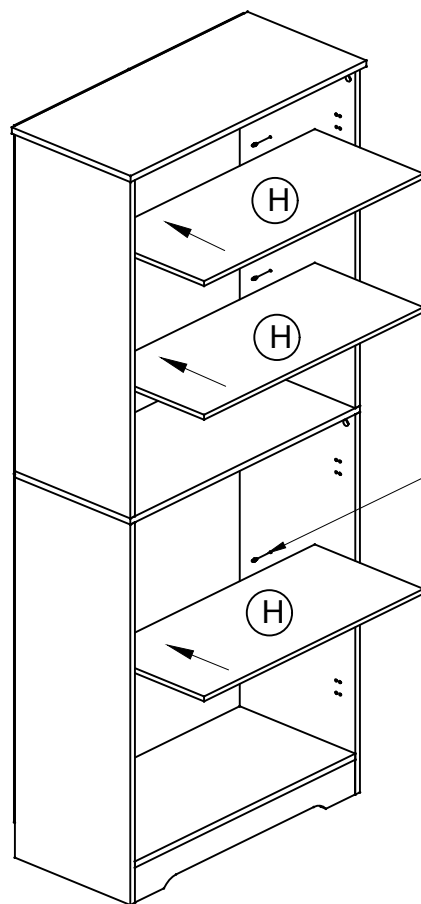
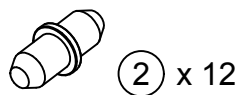

15

D3X12MM

M4*18MM



③ x 16



④ x 8

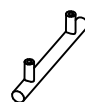

⑧ x 4



⑨ x 8

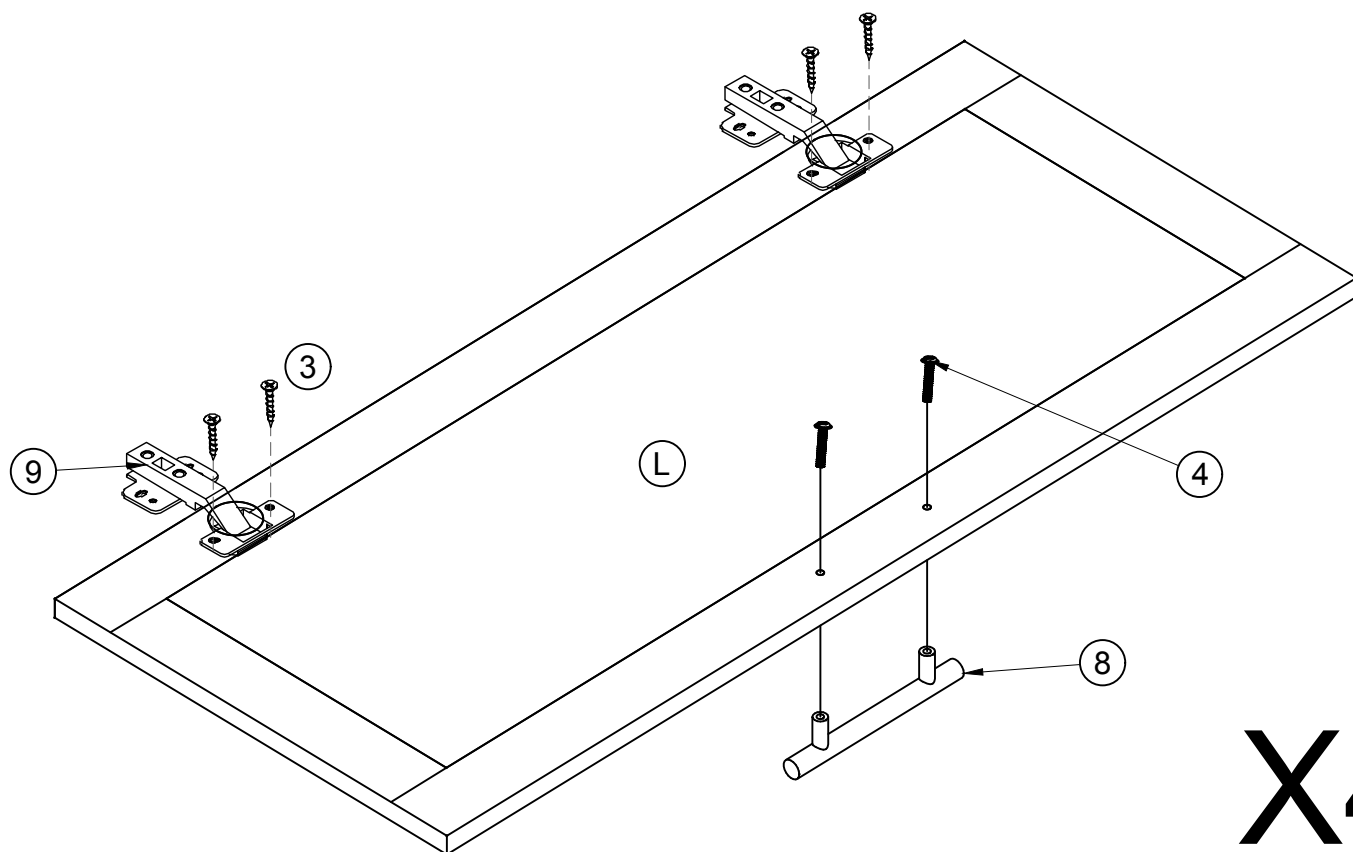

X4

16

D3X12MM

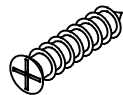

3 x 32

If the door gaps are uneven, Pls adjust as below

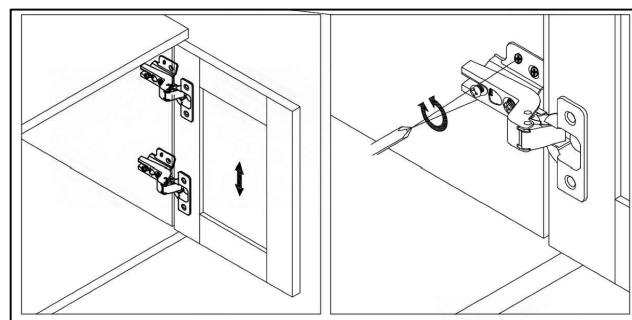
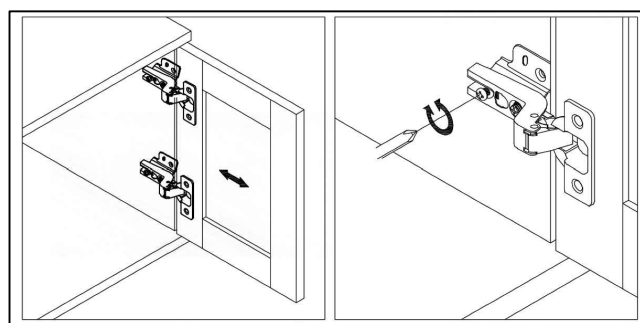
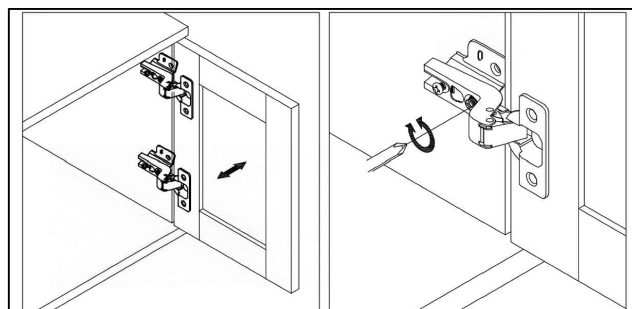
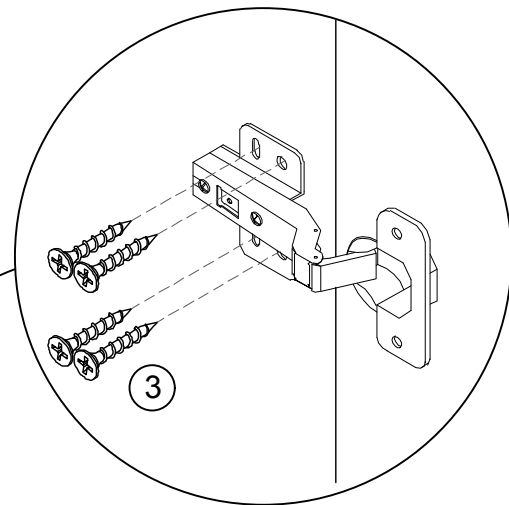
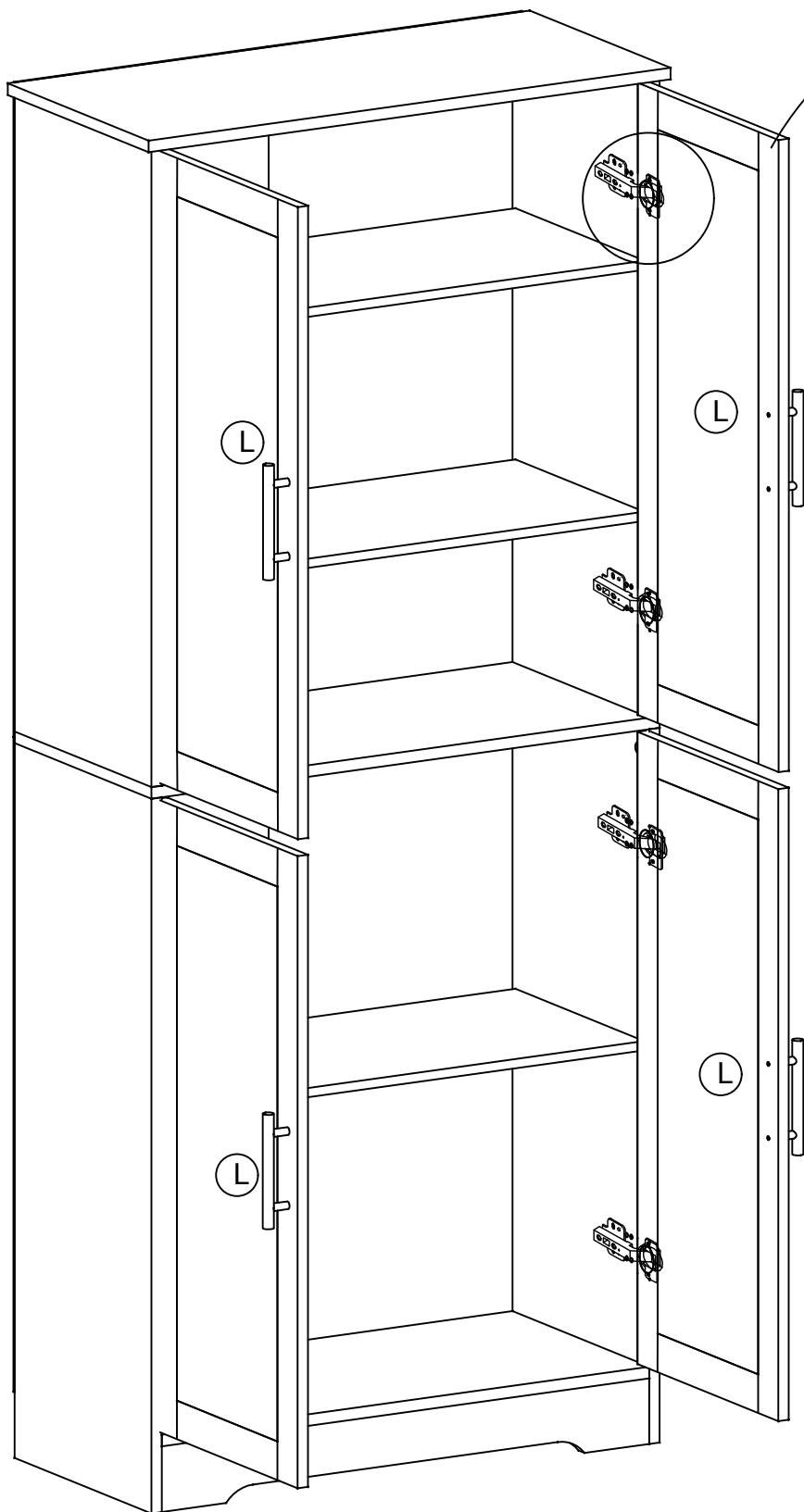

17

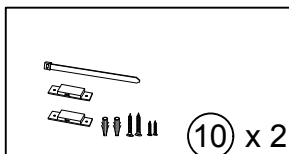

WALL

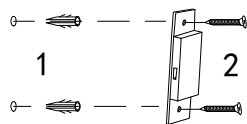

BOARD

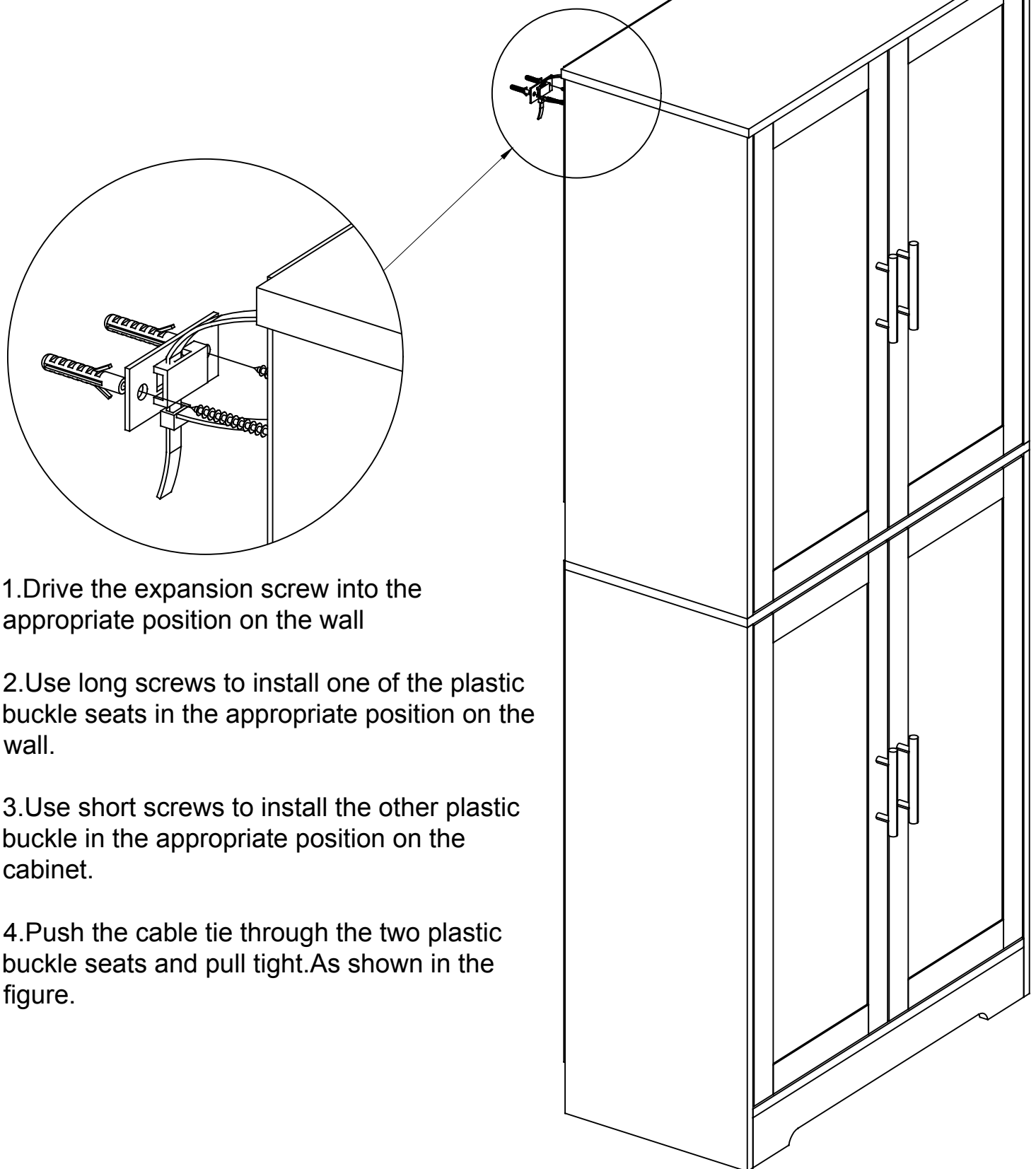
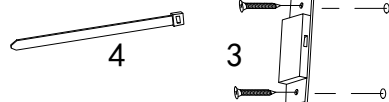

1. Drive the expansion screw into the appropriate position on the wall
2. Use long screws to install one of the plastic buckle seats in the appropriate position on the wall.
3. Use short screws to install the other plastic buckle in the appropriate position on the cabinet.
4. Push the cable tie through the two plastic buckle seats and pull tight. As shown in the figure.

18

Finished assembly

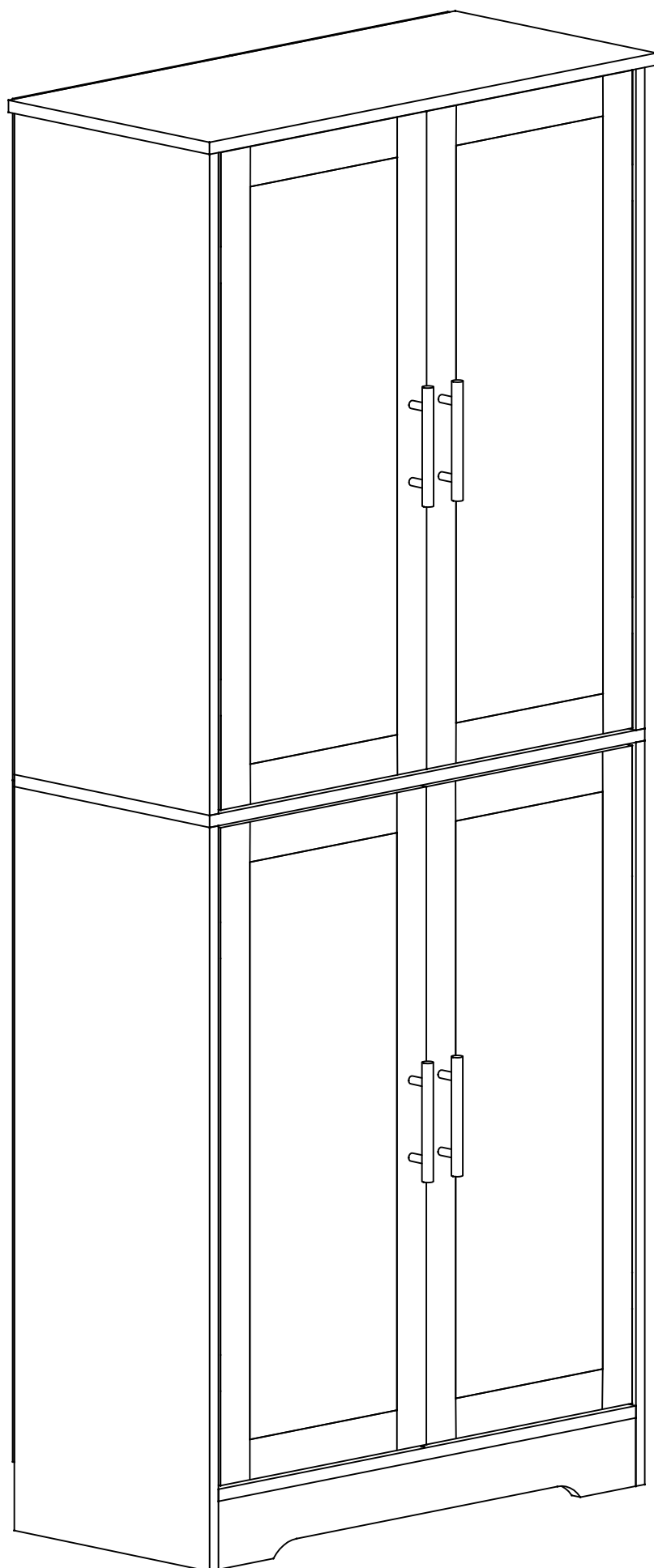

Dear customer, thank you for purchasing products! We are proud to present our customers with high quality products!



If you have any product quality or use problems, please contact our customer service by email, we will ensure your satisfaction.



If you are satisfied with our products, please share your amazing experience with us and other customers! It would be our honor to hear from you!