

Folding Table Assembly Instructions

Accessories	Quantity
Support rod	2
table leg	2
Horizontal bar	1
Thick horizontal bar	1
desktop	1
Caster wheel	4



Support rod



Horizontal bar



Thick horizontal bar

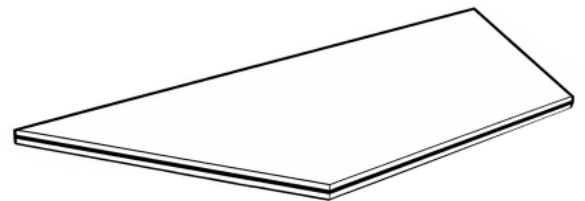

desktop

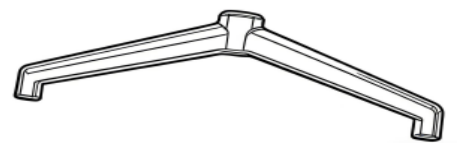
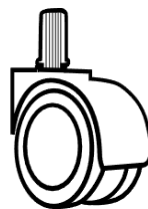

table leg



Eccentric Screw



Caster wheel



Desktop Connection Balancer



Desktop Support Bracket

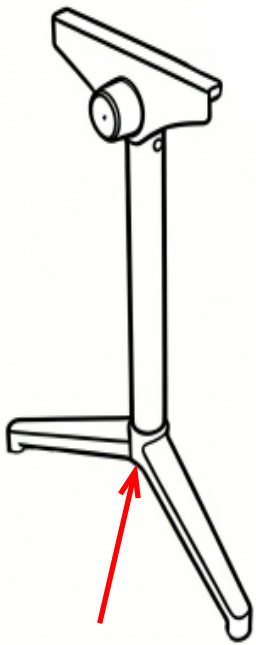

Step 1: Assemble the Support Poles and Table Legs First, assemble the support poles and table legs. Use hex socket screws and metal flat washers from the bottom of the table legs, and fix them to the support poles with a hex key. There are two table legs in total.

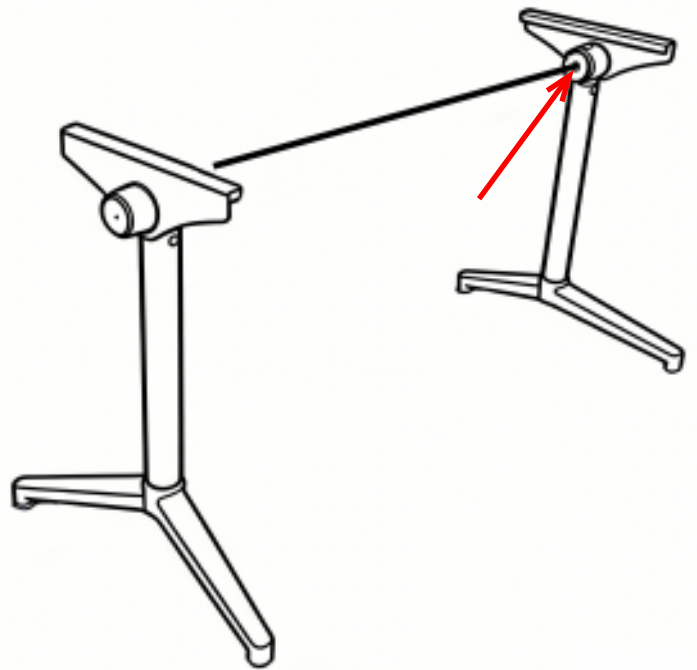

Step 2: Assemble the Crossbars First, assemble one end of the thin crossbar and fasten it slightly. Then slide the thick crossbar into the thin crossbar, connect the thin crossbar to the other table leg, and finally tighten the thick crossbar firmly.

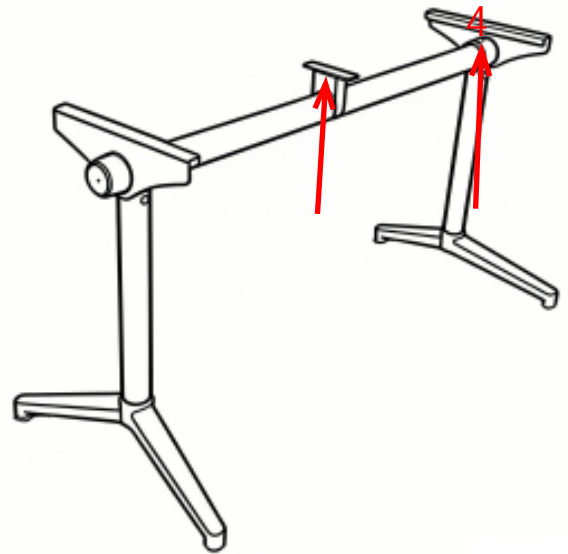
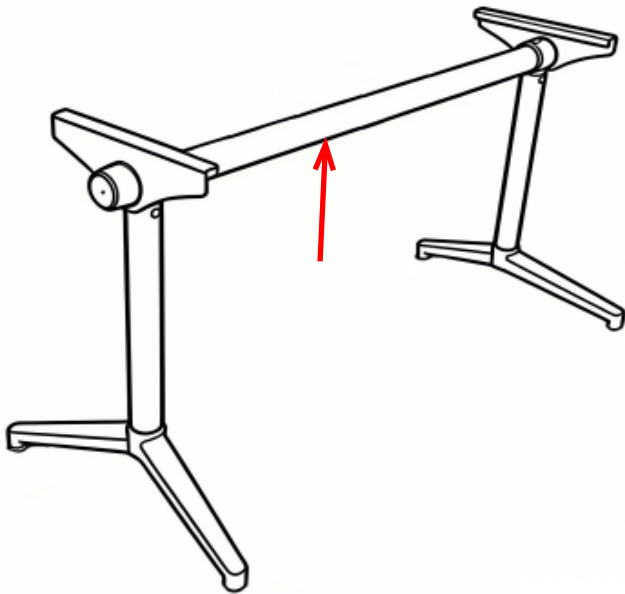

Step 3: Complete the Table Leg Bracket Assembly After the table leg bracket is assembled, first rotate the side switch to test whether it can be folded smoothly. Then install and fix the eccentric wheel at position 4. Finally, install the tabletop supports on the thick crossbar.

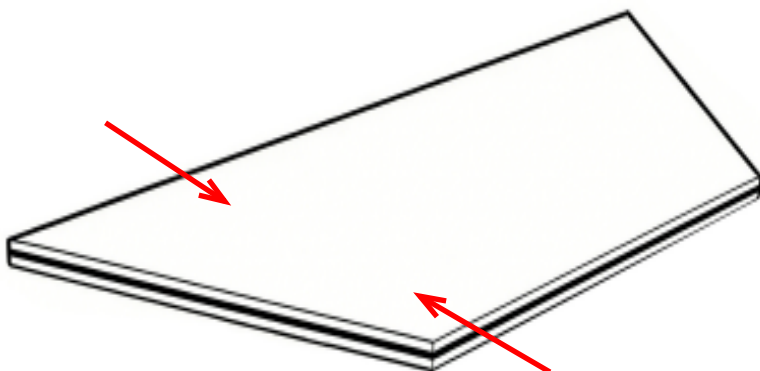

Step 4: Install the Tabletop and Universal Wheels Place the tabletop on a carpet or floor. Measure the distance between the two sides to ensure the table leg bracket is centered. Finally, fix the tabletop with self-tapping screws using an electric screwdriver. Install the universal wheels last. (You can use a wrench to adjust the levelness and tightness of the universal wheels.)