

# TWIN Assembly Instruction

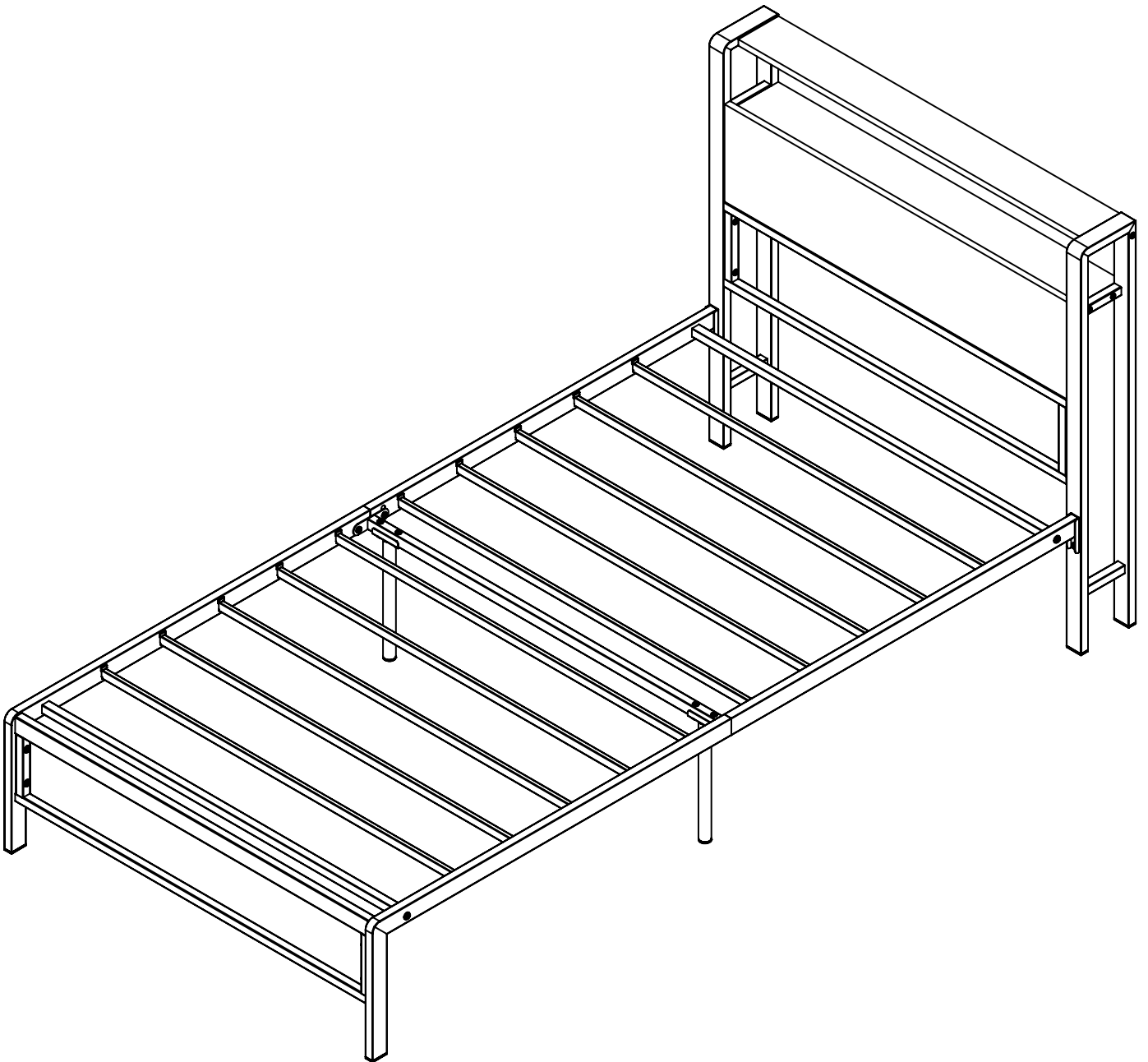

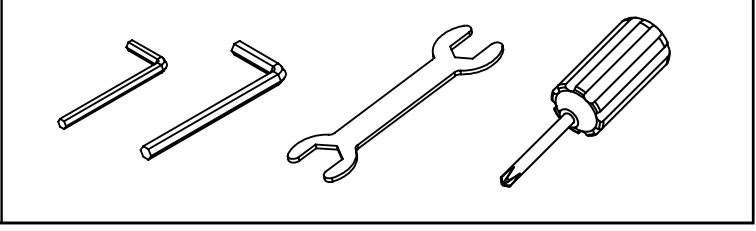

# Different screws display(1:1)

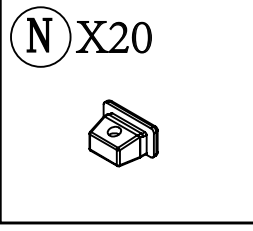
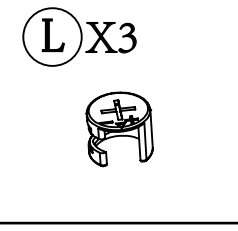
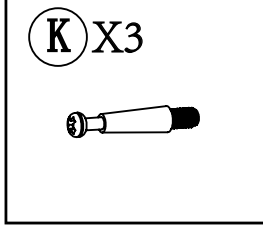
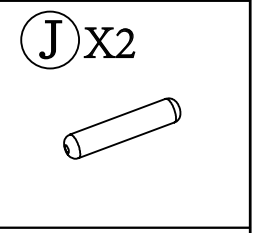
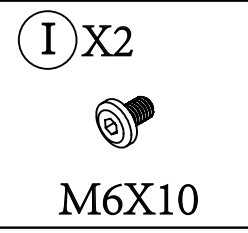
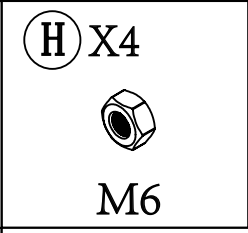
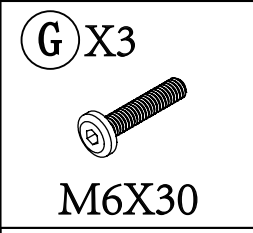
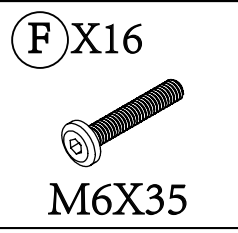
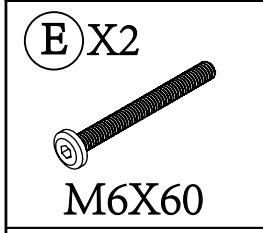
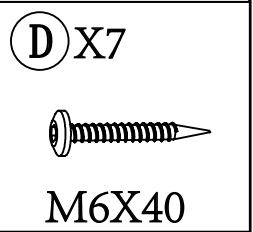
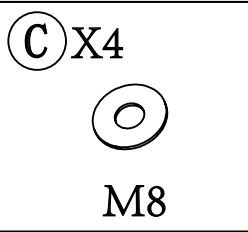
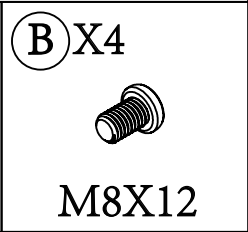
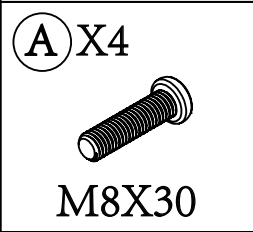
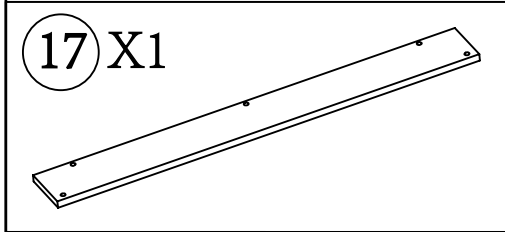
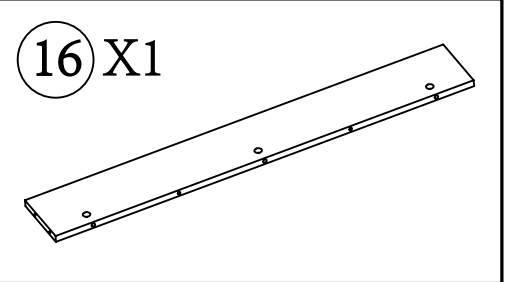
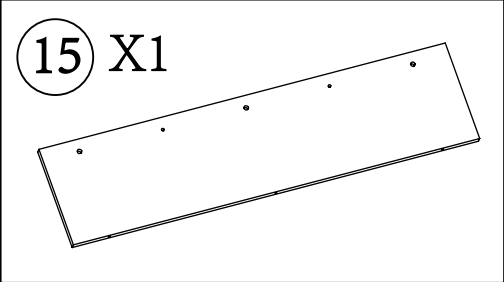
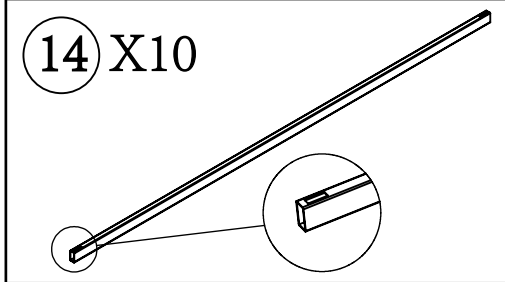
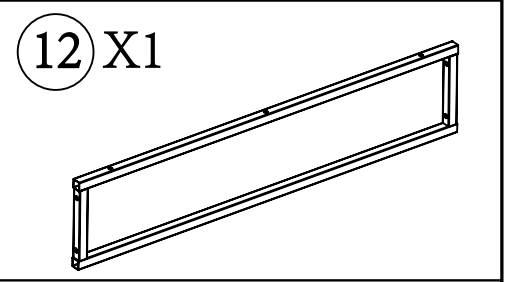
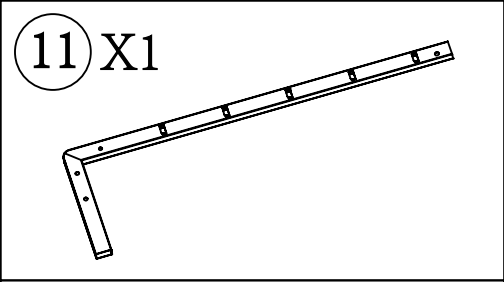
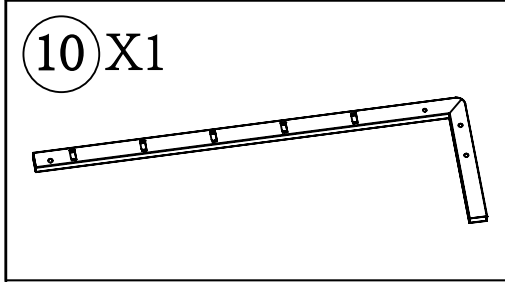
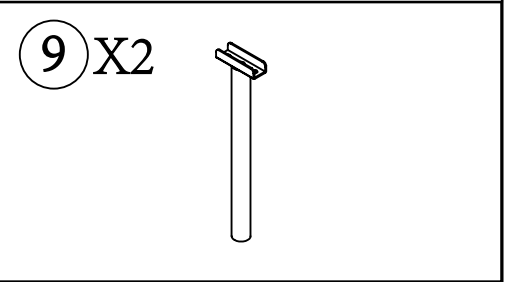
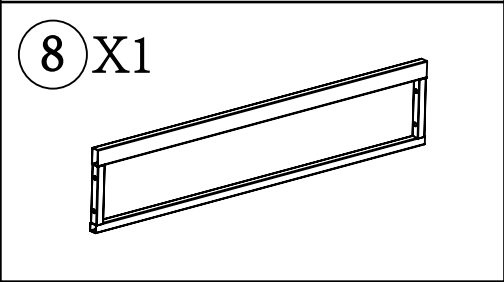
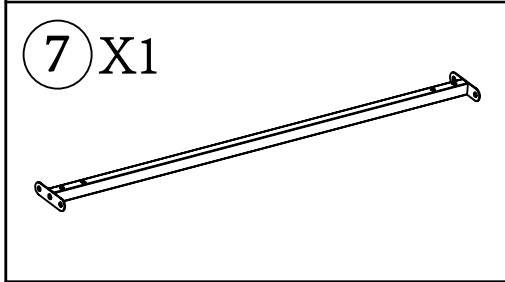
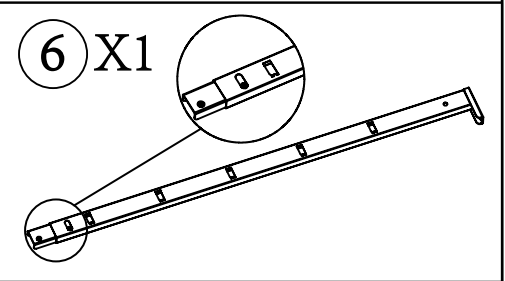
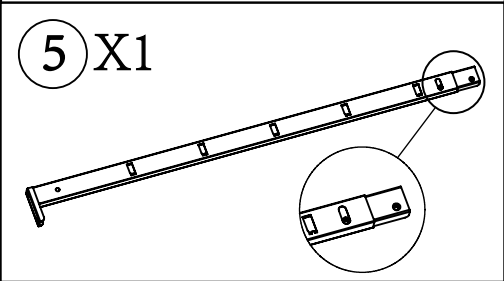
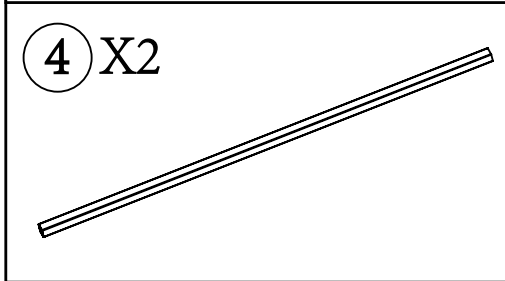
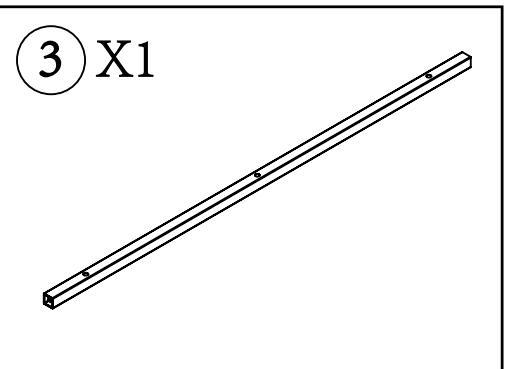
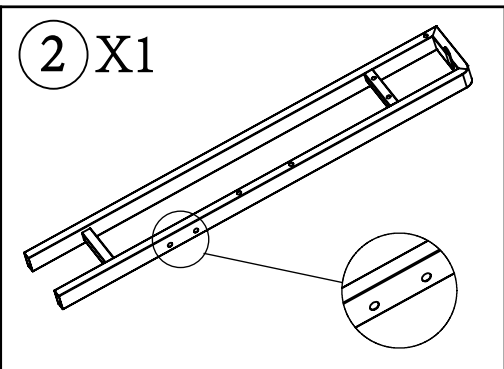
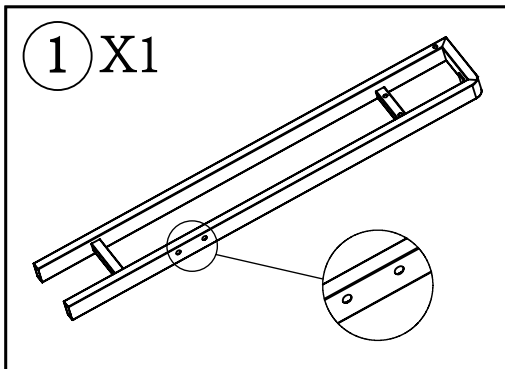
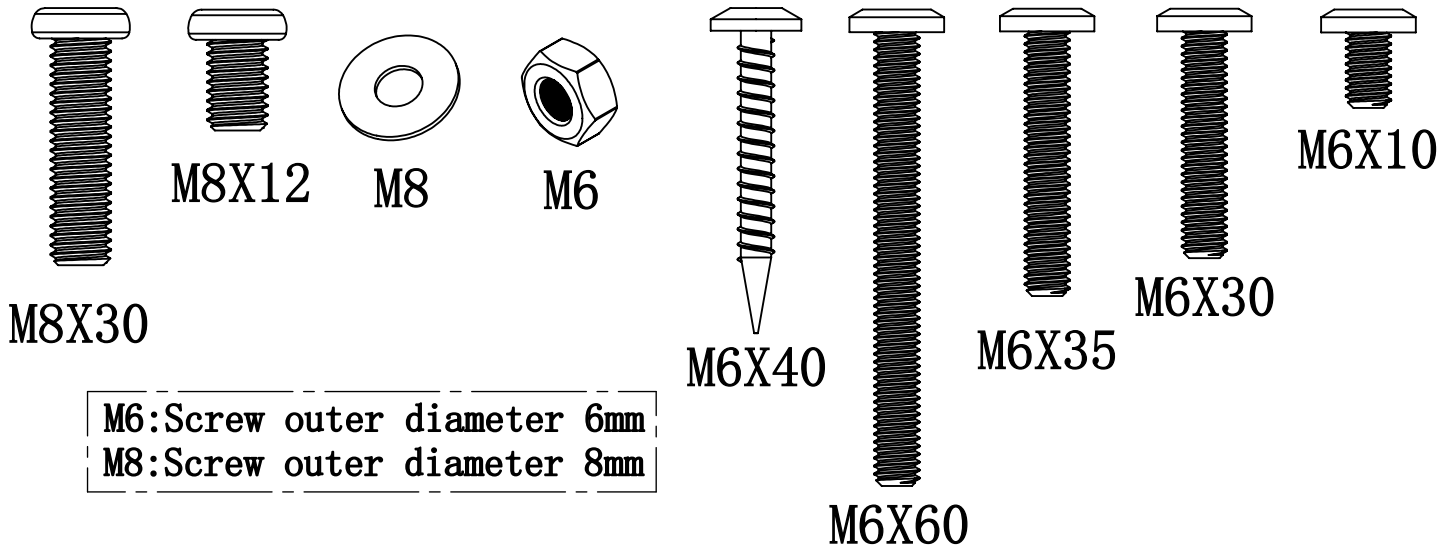

M6:Screw outer diameter 6mm  
M8:Screw outer diameter 8mm

step 1

E	M6X60	2
F	M6X35	4

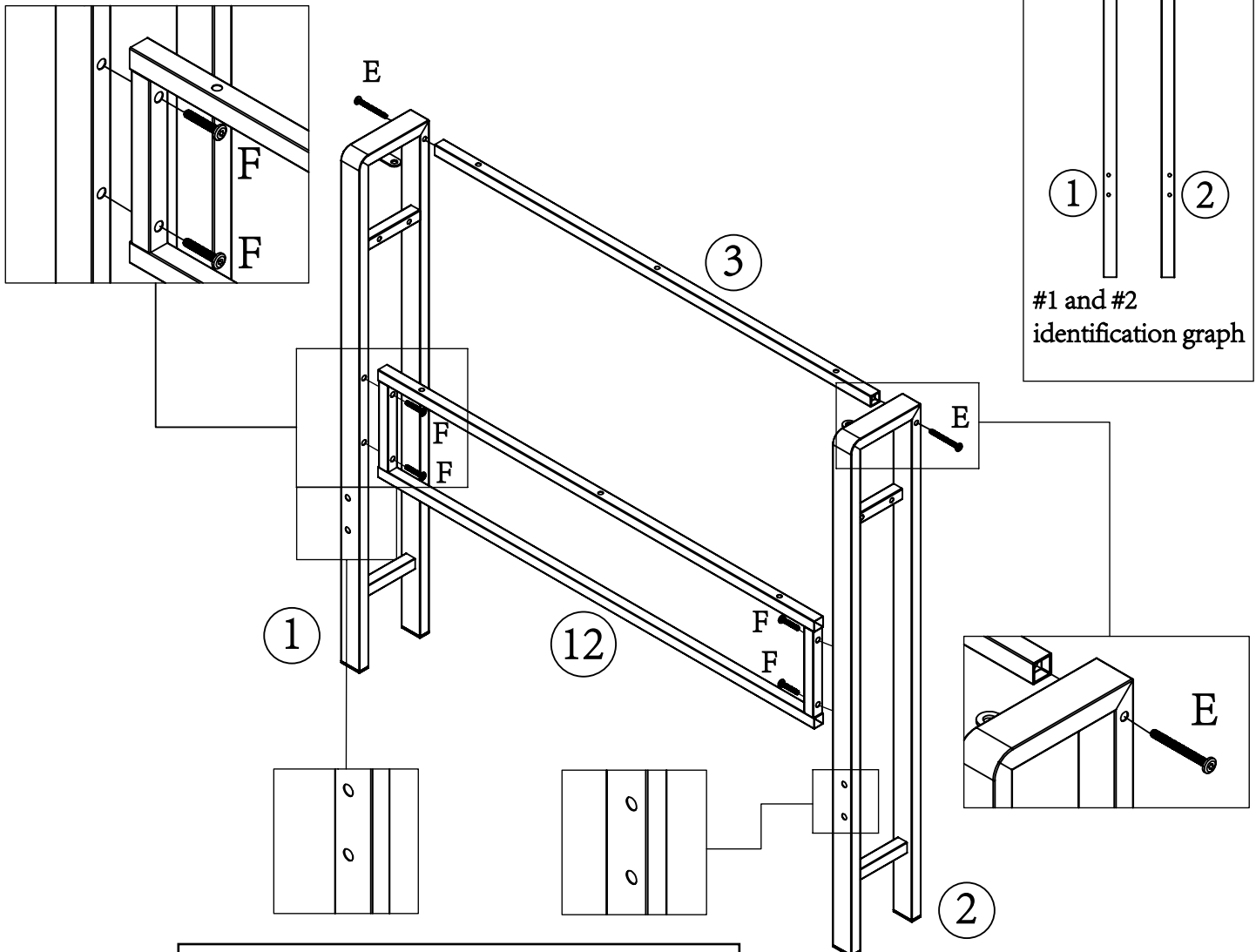

Hole #1 is located on the left side  
Hole #2 is located on the right side

step 2

D	M6X40	4
---	-------	---

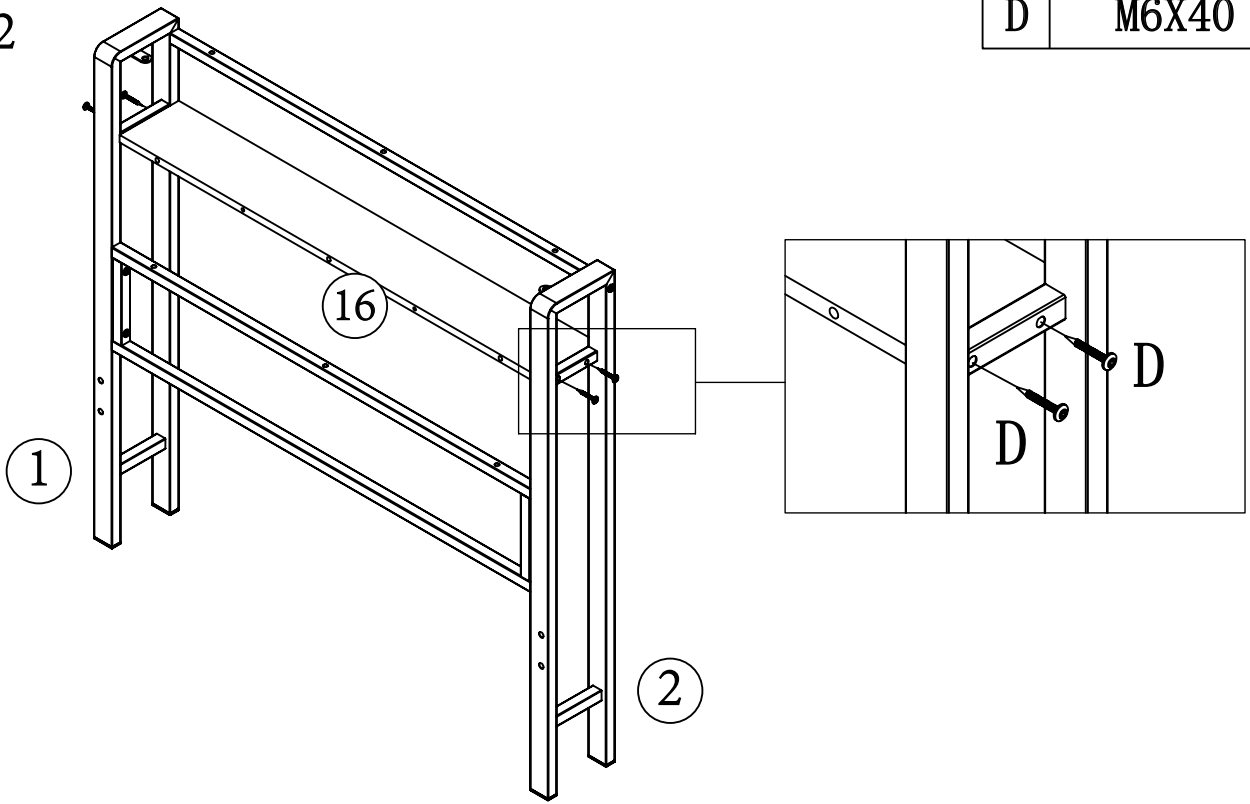

step 3

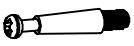
J		2
K		3

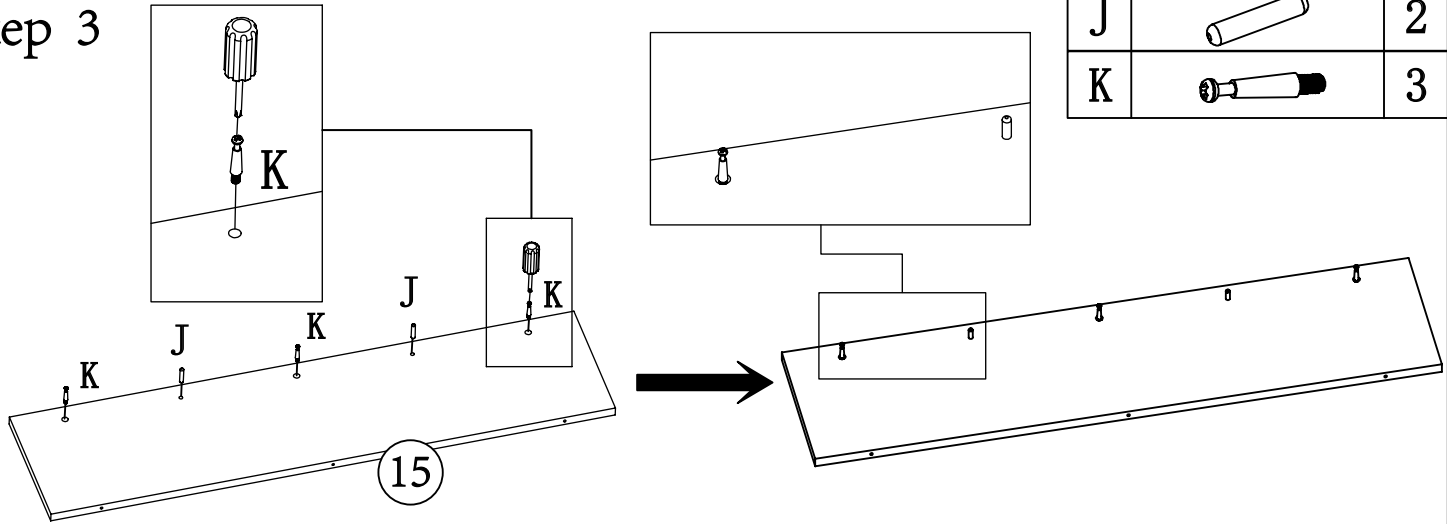

step 4

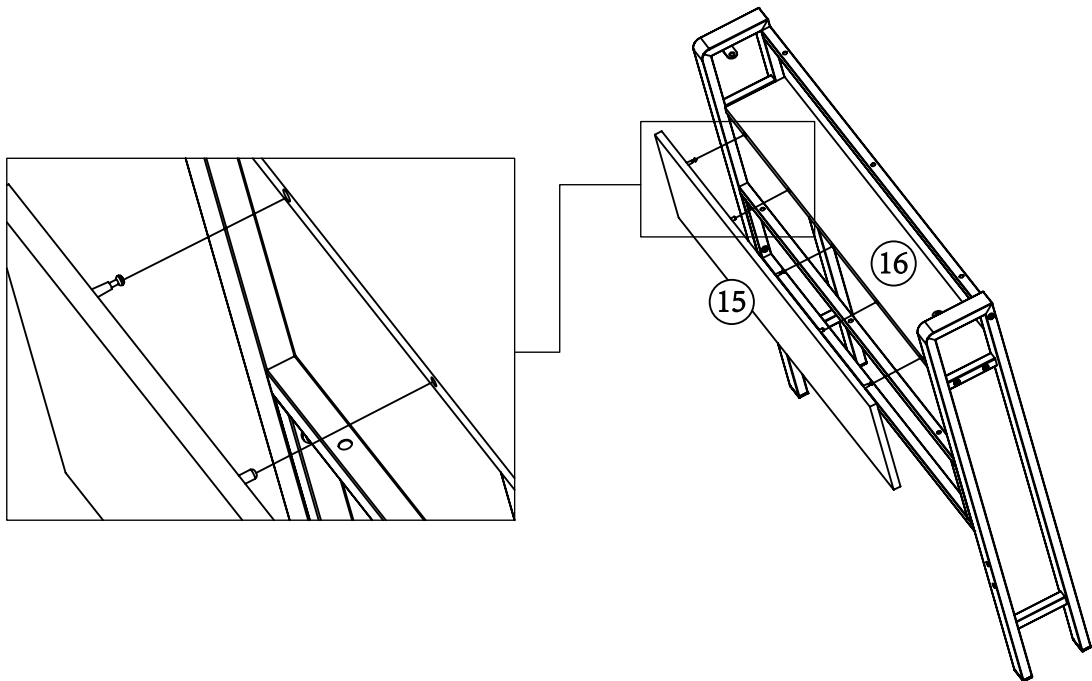

step 5

D	M6X40	3
---	-------	---

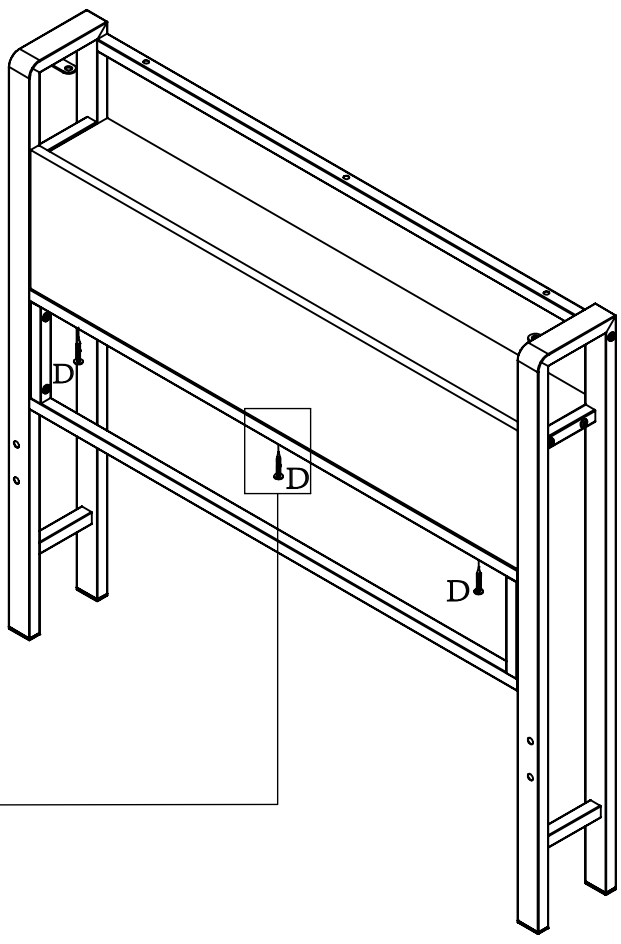
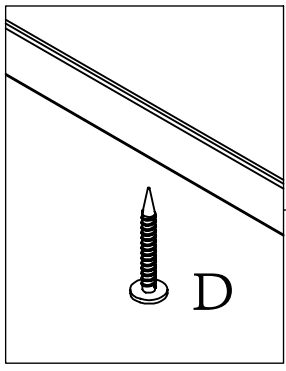

step 6

L		3
---	---	---

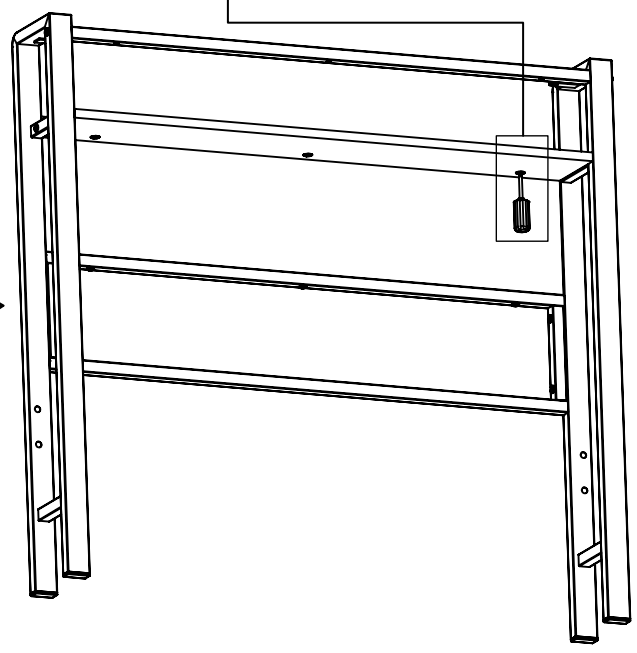
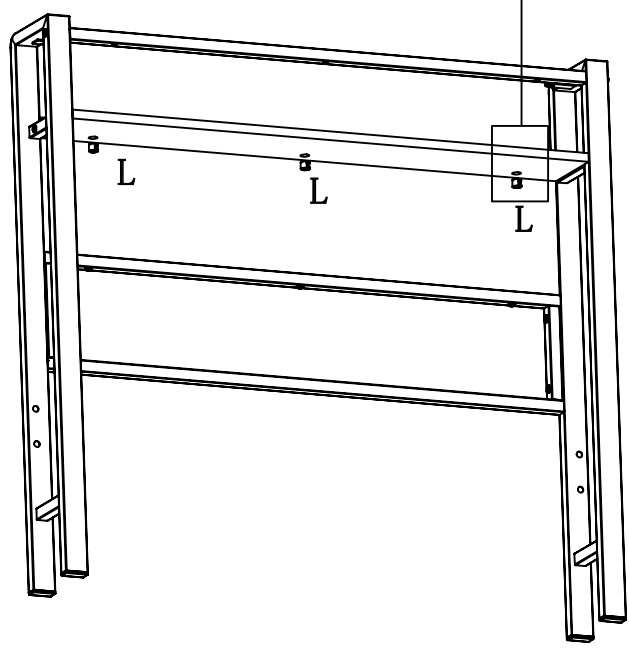
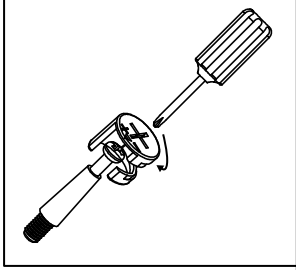
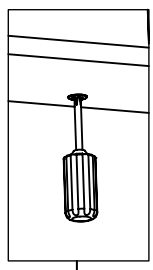
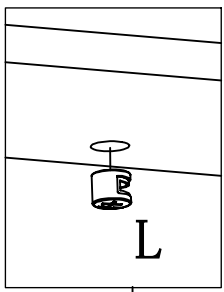

# step 7

G	M6X30	3
I	M6X10	2

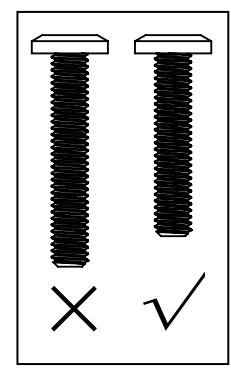
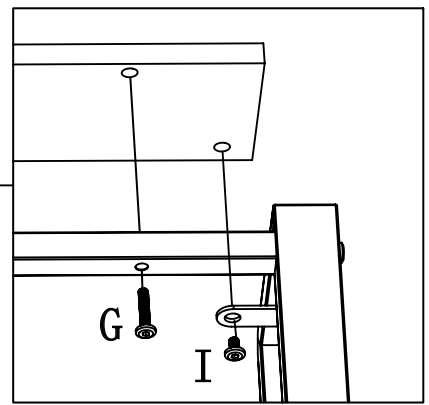
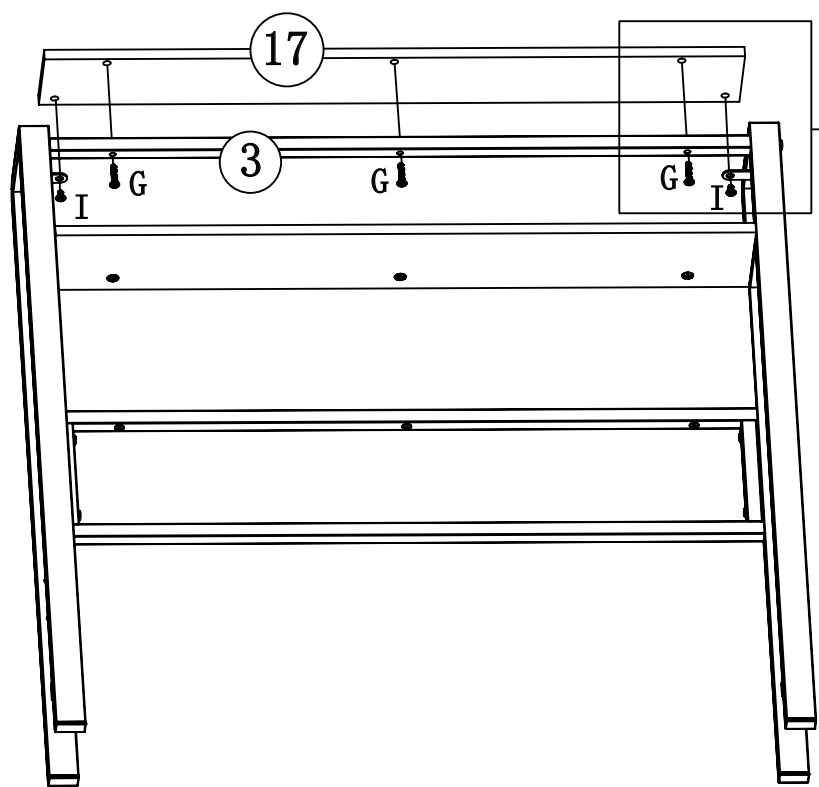

Please use M6X30 screws, don't use M6X35 screws

# step 8

A	M8X30	4
C	M8	4
F	M6X35	2

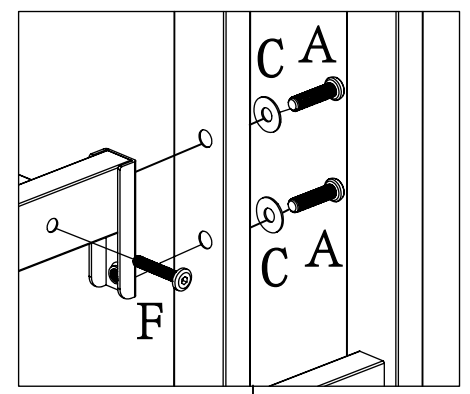
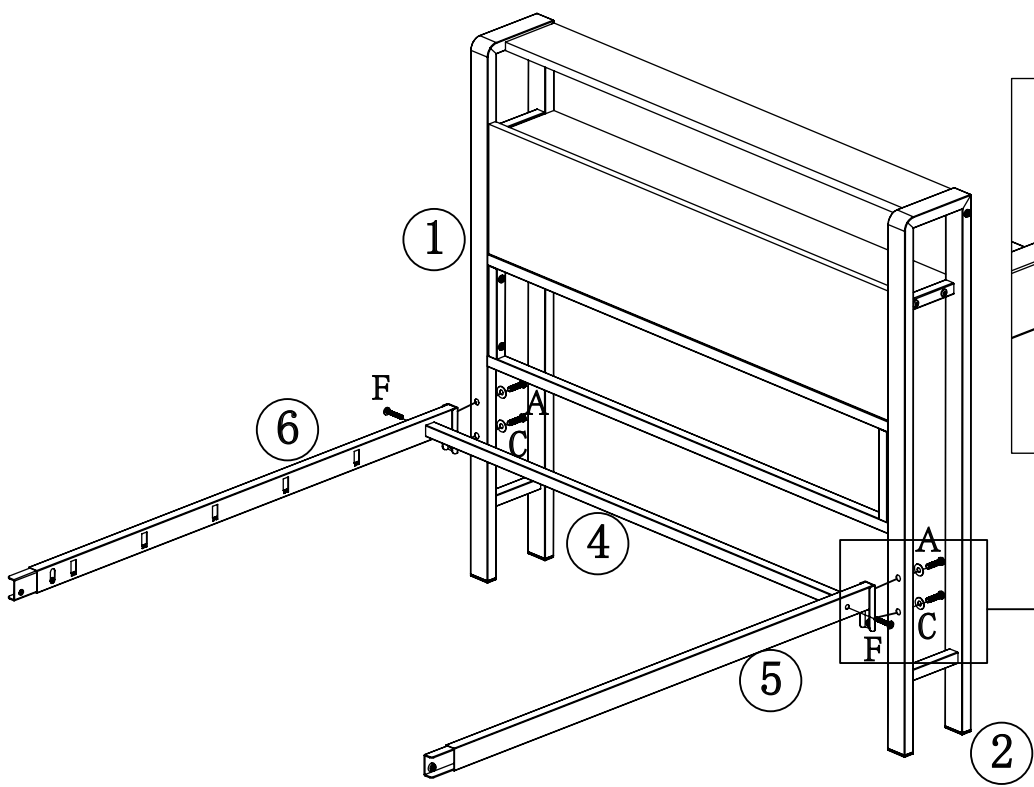

step 9

F	M6X35	6
---	-------	---

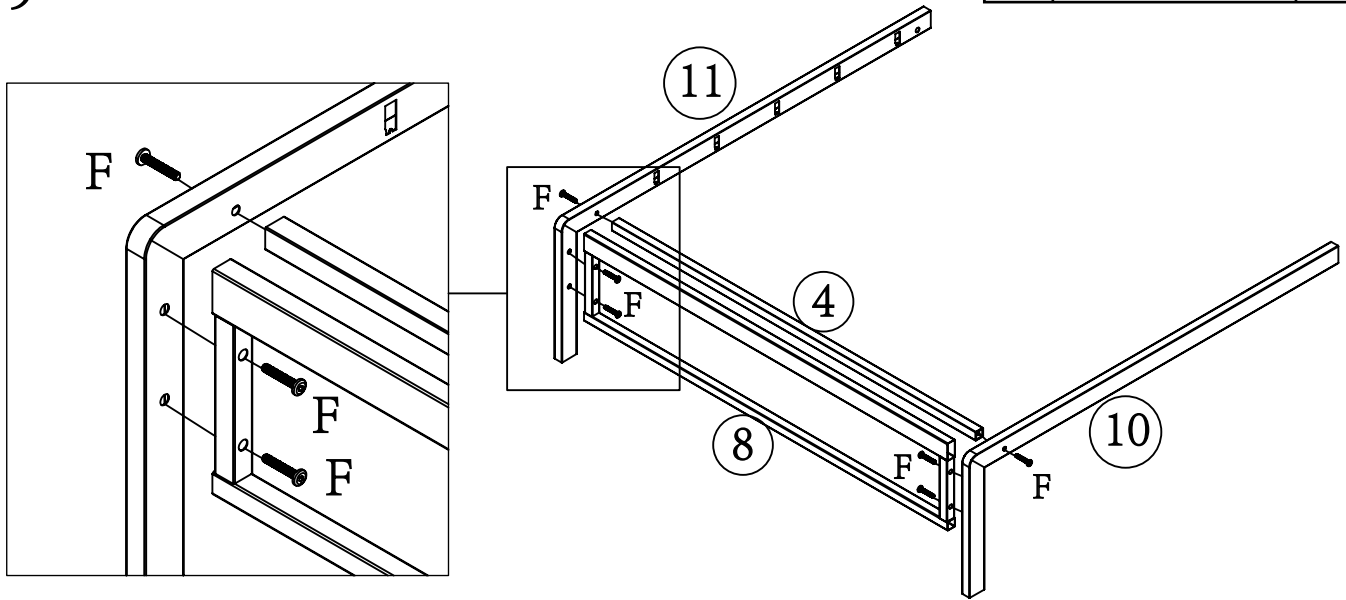

step 10

F	M6X35	4
H		4

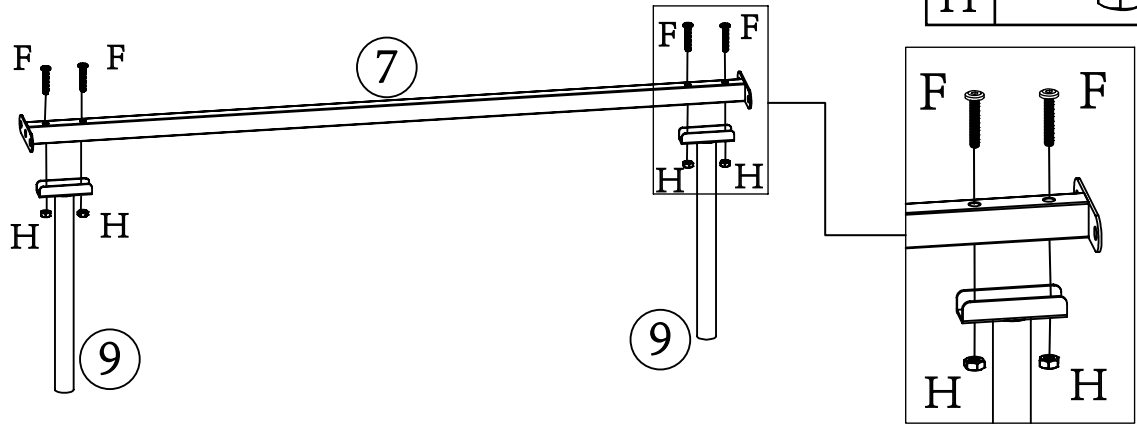

step 11

B	M8X12	4
---	-------	---

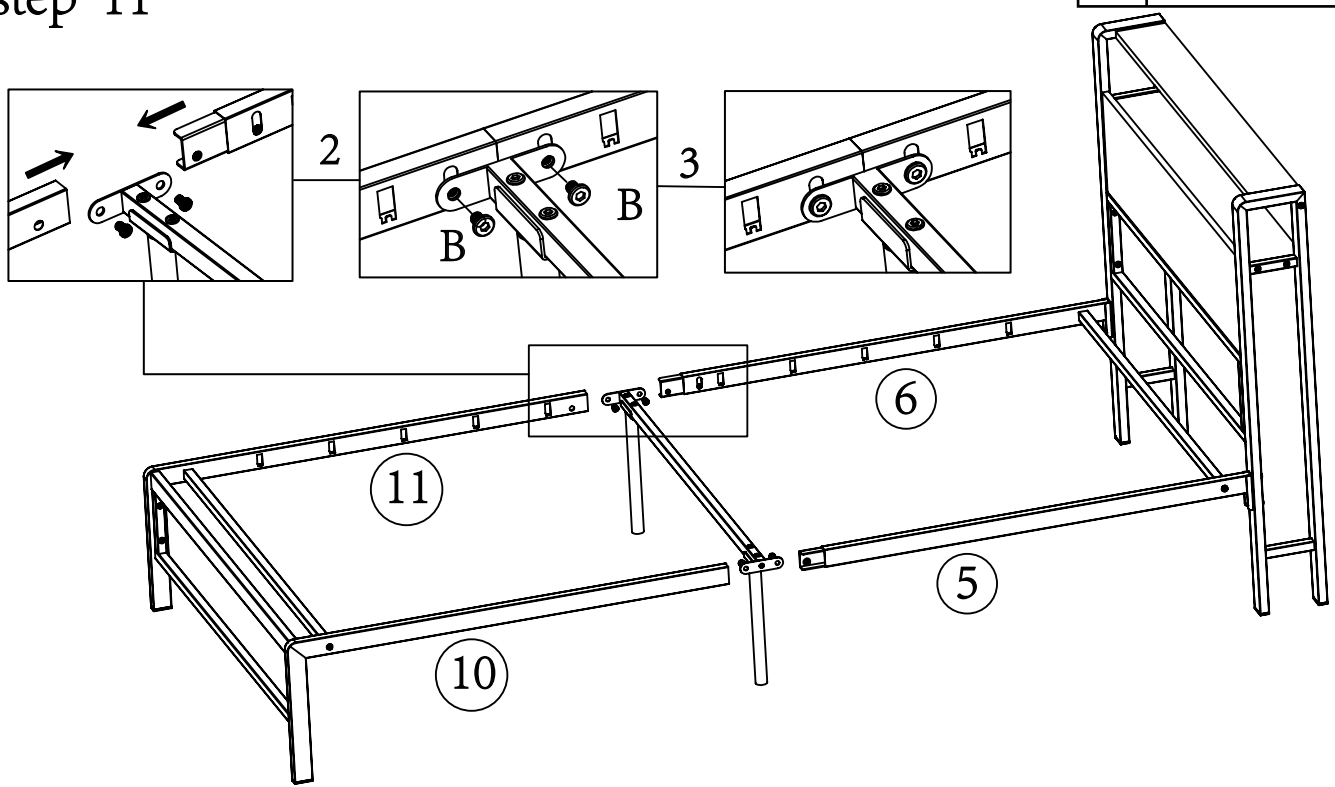

step 12

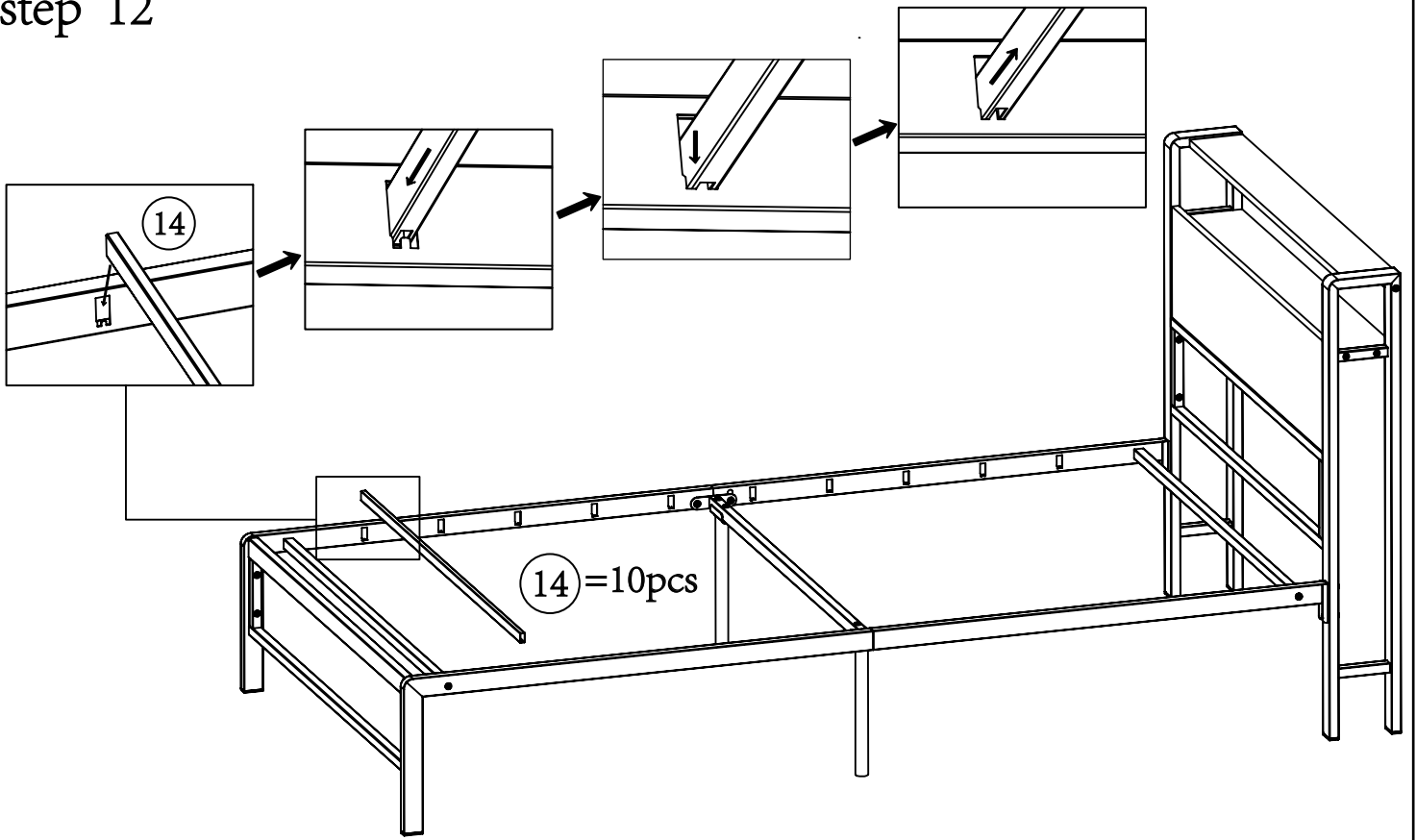

step 13

