

ASSEMBLY INSTRUCTIONS

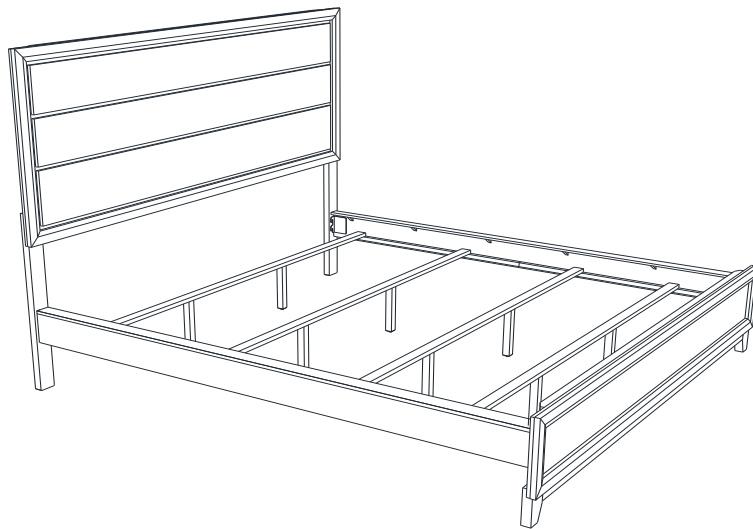

Fine Furniture for every stage of life

California King Bed

REVISION 0 : 01/18/2021
REVISION 1 : 07/12/2023

PAGE 1 OF 4

ASSEMBLY INSTRUCTIONS

ASSEMBLY TIPS:

1. Remove hardware from box and sort by size.
2. Please check to see that all hardware and parts are present prior to start of assembly.
3. Please follow attached instructions in the same sequence as numbered to assure fast & easy assembly.



WARNING!

1. Don't attempt to repair or modify parts that are broken or defective. Please contact the store immediately.
2. This product is for home use only and not intended for commercial establishments.









ASSEMBLY TIME



20 MINUTES

PARTS IDENTIFICATION

B1 (BOX 1)



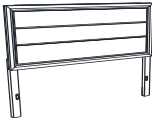

<p>A HEADBOARD PANEL</p>  <p>1PC</p>	<p>D LEFT HEADBOARD LEG</p>  <p>1PC</p>
<p>B FOOTBOARD</p>  <p>1PC</p>	<p>E BED SLAT</p>  <p>4PCS</p>
<p>C RIGHT HEADBOARD LEG</p>  <p>1PC</p>	<p>F BED SLAT SUPPORT WITH LEVELER</p>  <p>8PCS</p>

B2 (BOX 2)

<p>G BED RAIL</p>  <p>2PCS</p>	<p>B (B1) FROM BOX 1 FOOTBOARD</p>  <p>1PC</p>
<p>HB (B1) FROM BOX 1 HEADBOARD COMPLETE</p>  <p>1PC</p>	

HARDWARE IDENTIFICATION

Z-B1 (BOX 1) - HARDWARE PACK IS LOCATED IN (B1)

<p>1 BOLT (M6 x 30mm - BLK)</p>  <p>6PCS</p>	<p>4 SMALL ALLEN WRENCH (M4 x 60mm - BLK)</p>  <p>1PC</p>
<p>2 LOCK WASHER (1/4" - BLK)</p>  <p>6PCS</p>	<p>5 BIG ALLEN WRENCH (M5 x 65mm - BLK)</p>  <p>1PC</p>
<p>3 FLAT WASHER (1/4"ID x 13mm - BLK)</p>  <p>6PCS</p>	

Z-B2 (BOX 2) - HARDWARE PACK IS LOCATED IN (B2)

<p>6 PAN HEAD SCREW (M3.5 x 16mm - BLK)</p>  <p>16PCS</p>	<p>7 L-BRACKET</p>  <p>8PCS</p>
---	---

NOTE:

Phillips head screw driver is required in the assembly process; however, manufacturer does not provide this item.

ASSEMBLY INSTRUCTIONS

STEP 1

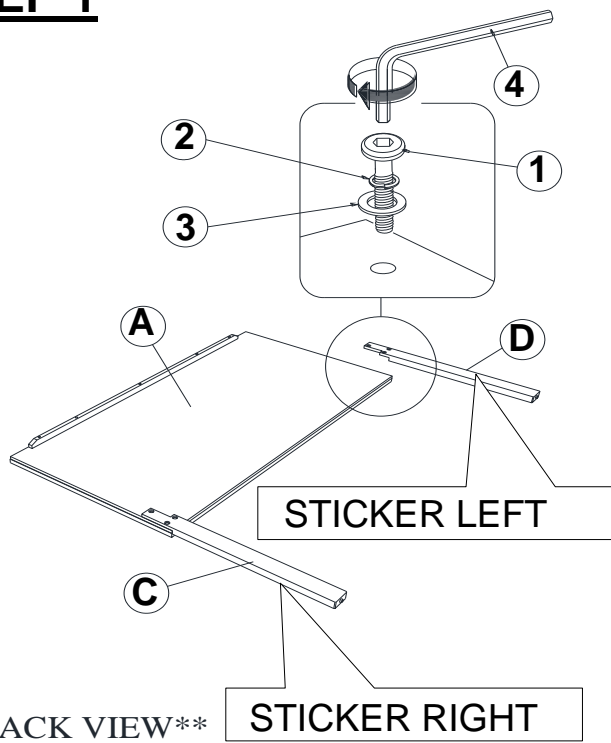

Note: Please take note of the marking sticker (L & R) on the headboard legs.

STEP 2

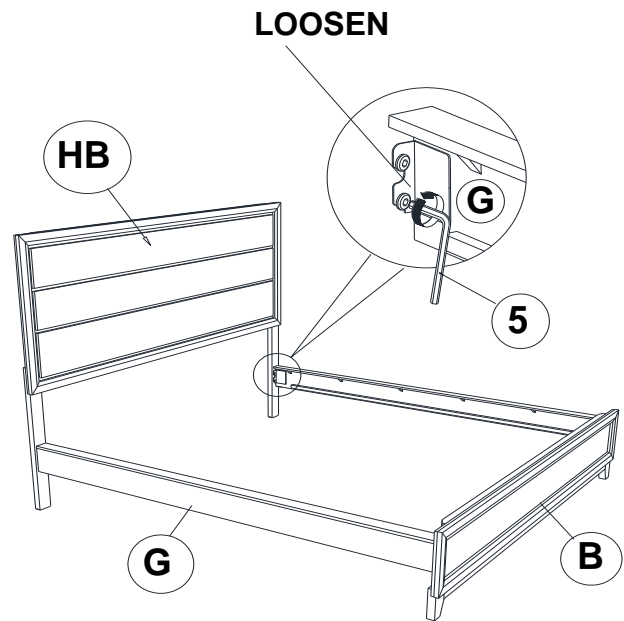

STEP 3

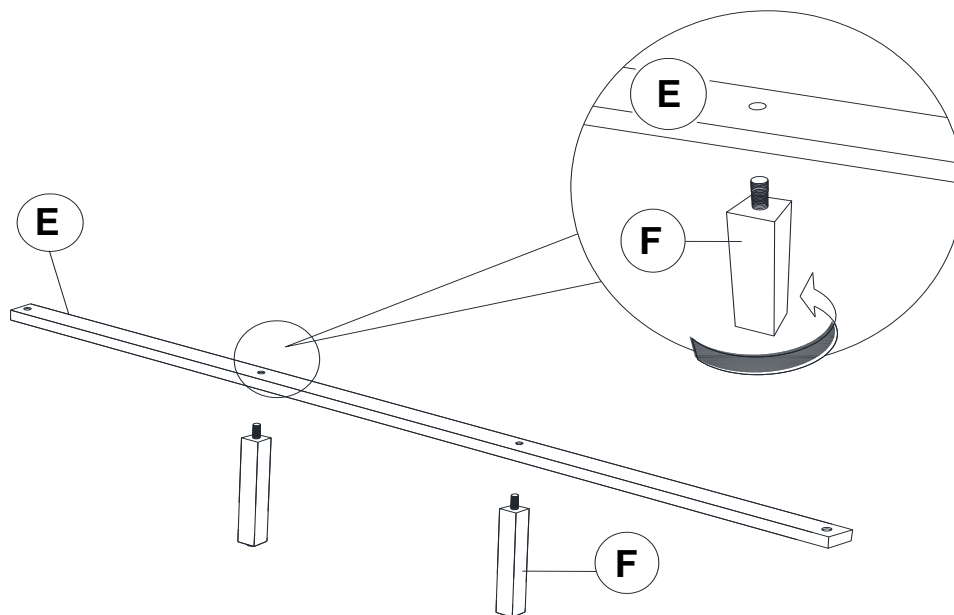

ASSEMBLY INSTRUCTIONS

STEP 4

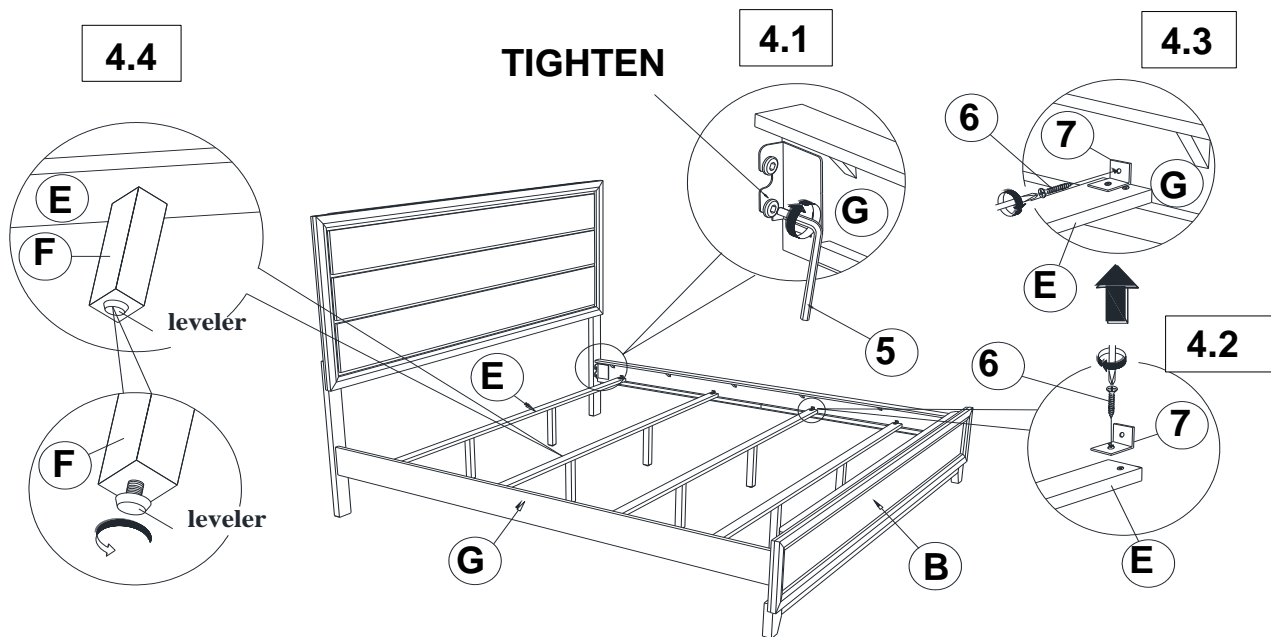

STEP 5 COMPLETE

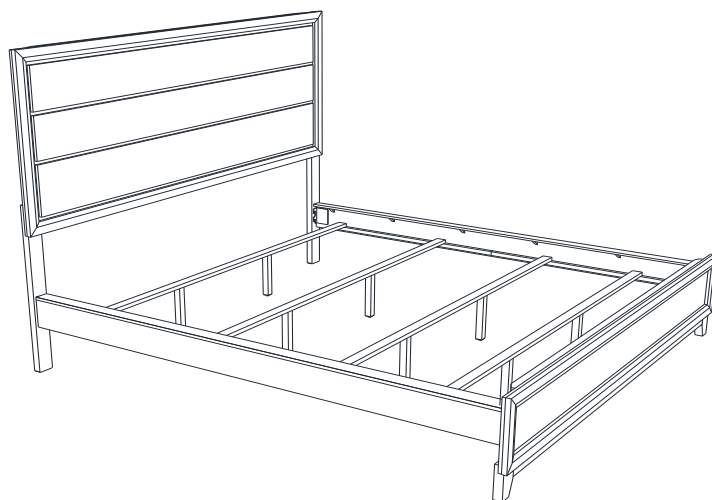

Inner Size : 76.75"W X 86.00"D

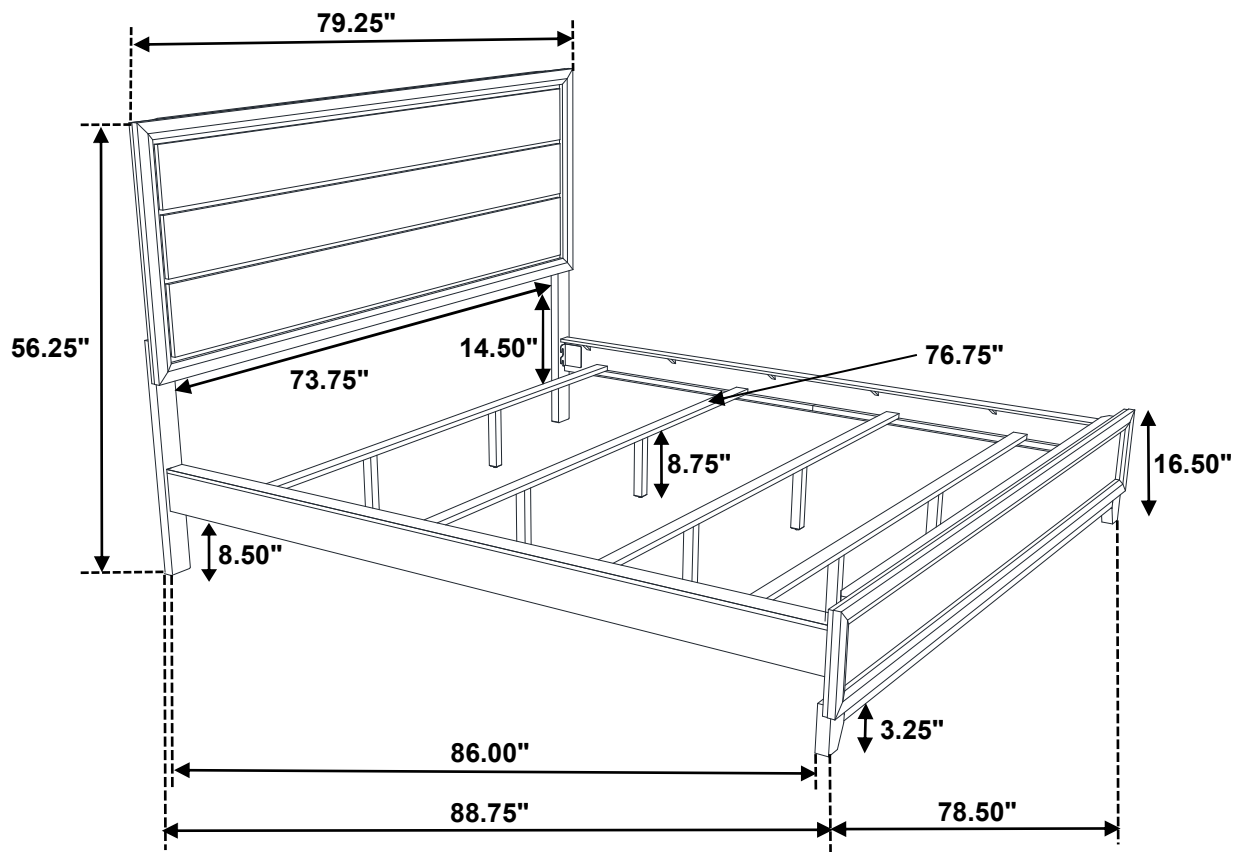

Note : Dimension tolerance $\pm 5\%$