

BAR STOOL
TABOURET DE BARRA
TABURETE DE BARRA

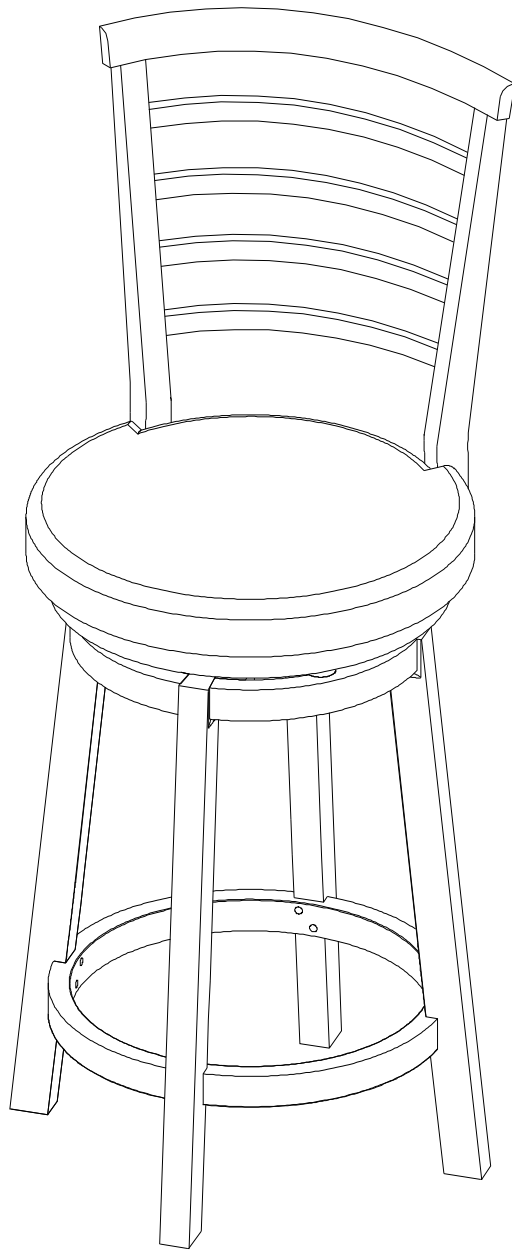

HARDWARE LIST

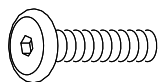
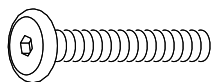

H1 x 04
Ø 1/4"x1-3/16"



H2 x 10
Ø 1/4"x1-3/4"



H3 x 04
Ø1/4"x2-3/16"

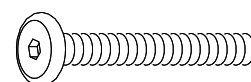

H4 x 04
Ø1/4"x2-3/8"



H5 x 02
Ø1/4"x 1-3/4"



H6 x 24
Ø1/4"



H7 x 24
Ø1/4"x1.5mm

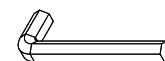

H8 x 01
4mm

PART LIST

PARTS	DESCRIPTION	QTY
A	CHAIR BACK	01
B	CUSHION SEAT WITH FRAME	01
C	UPPER RING W/10" SWIVEL	01
D	CHAIR LEG	04
E	LOWER RING	01

IMPORTANT:

1. Do not tighten bolts completely until all bolts are completely lined up and inserted into holes / nuts.
2. Do not over tighten screws and bolts to avoid stripping.
3. Please use hand tools to assemble this product. Do not use power tools.

IMPORTANT:

1. Ne serrez pas complètement les boulons jusqu'à ce que tous les boulons soient complètement alignés et insérés dans les trous / écrous..
2. Ne pas trop serrer les vis et les boulons pour éviter le décapage.
3. Utilisez des outils à main pour assembler ce produit. N'utilisez pas d'outils électriques.

IMPORTANTE:

1. No apriete completamente los pernos hasta que todos los tornillos estén alineados completamente y se inserten en los agujeros / tuercas.
2. No apriete demasiado los tornillos y los pernos para evitar que se pelen.
3. Utilice herramientas de mano para montar este producto. No utilice herramientas eléctricas.

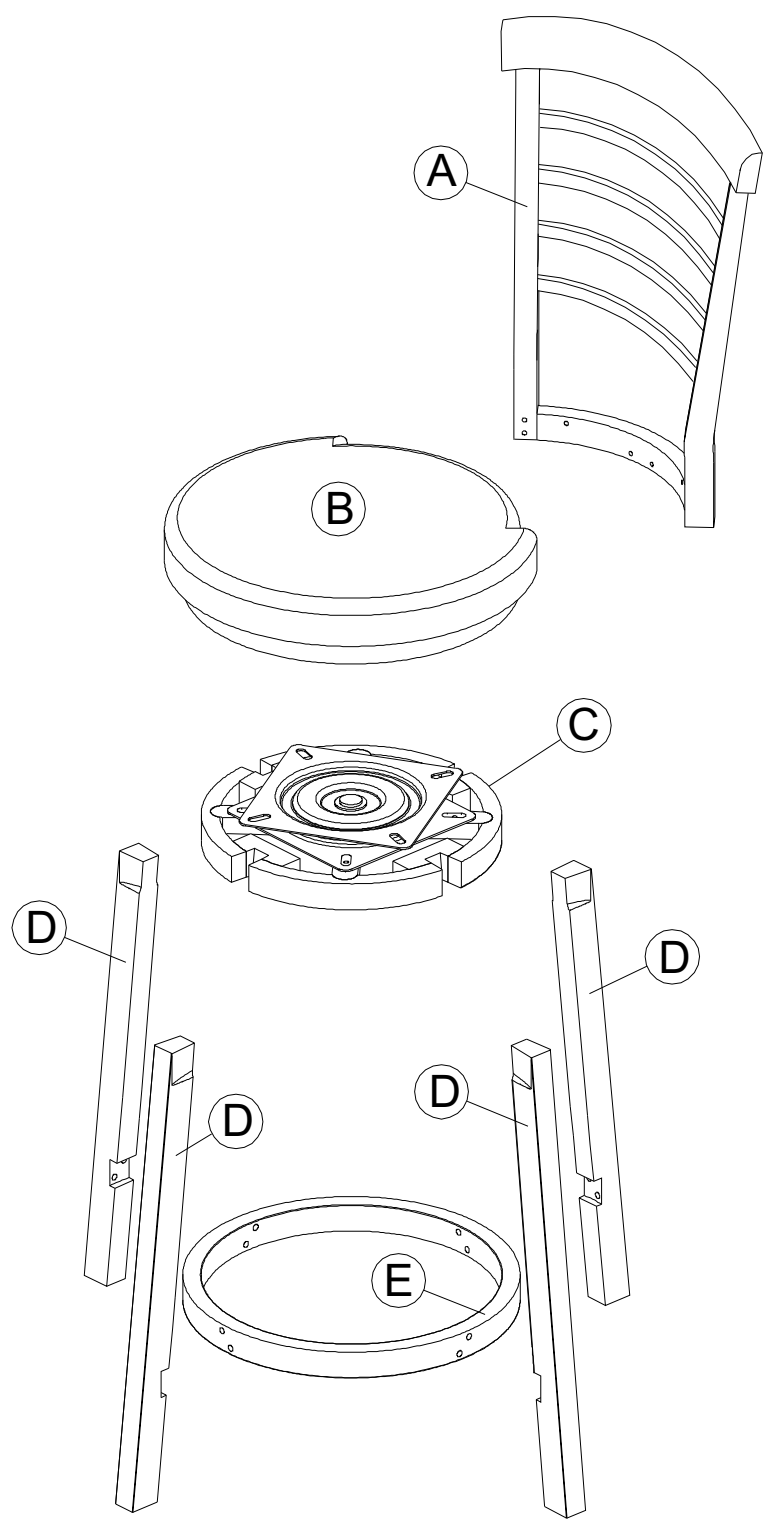

STEP 1
ÉTAPE 1
PASO 1

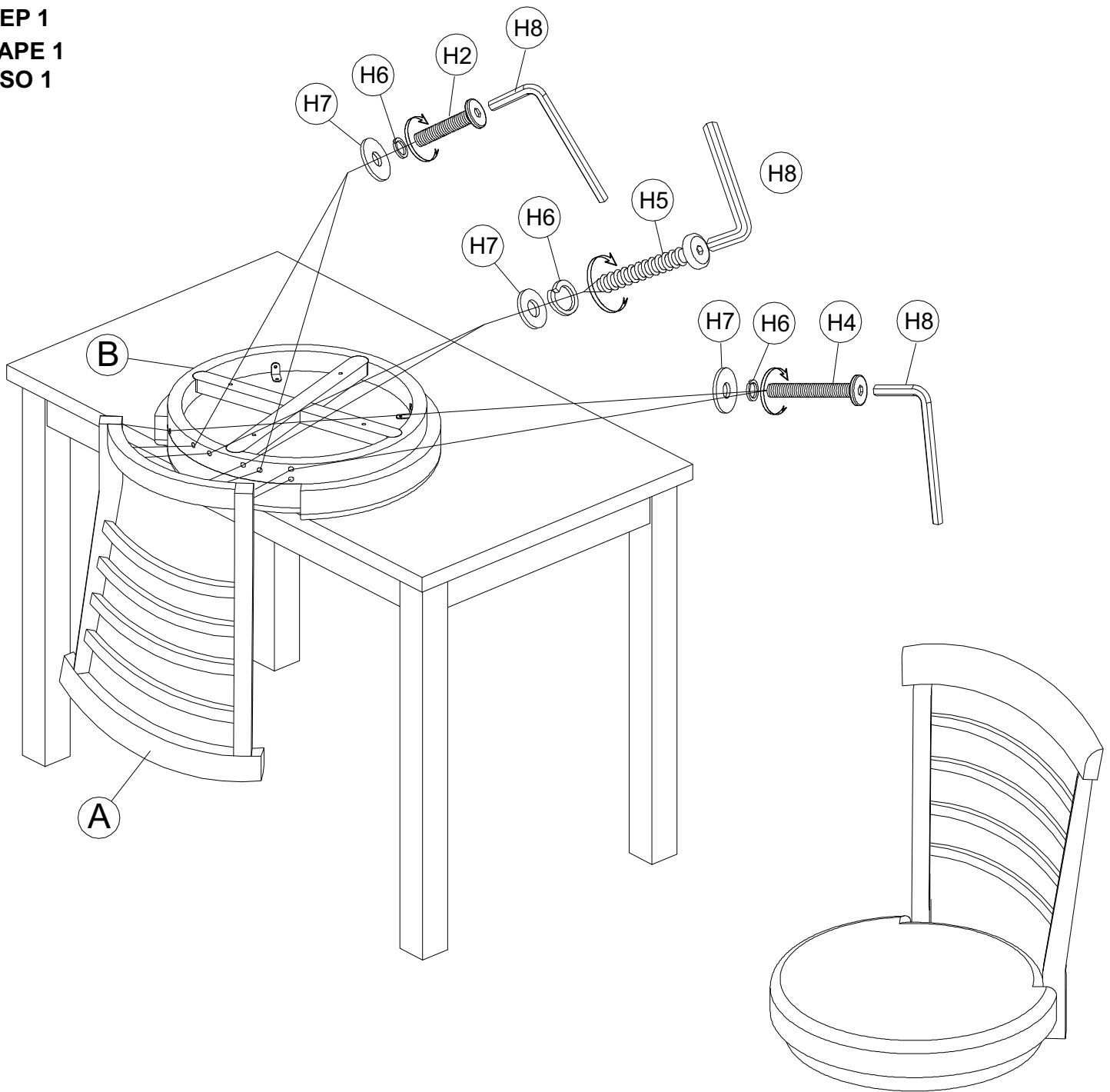

(H2)		2
(H4)		4
(H5)		2
(H6)		8
(H7)		8
(H8)		1

STEP 2
ÉTAPE 2
PASO 2

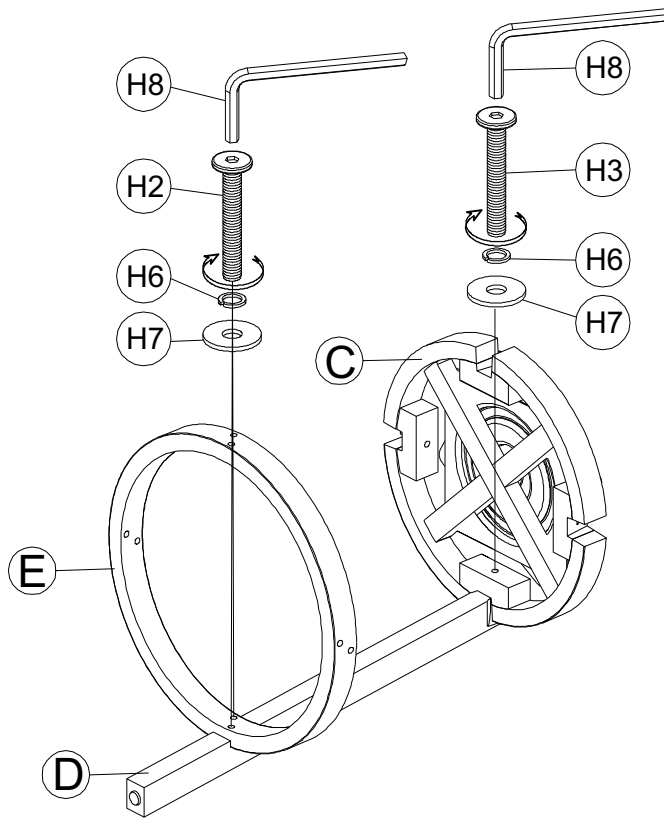

H2		2
H3		1
H6		3
H7		3
H8		1

STEP 3
ÉTAPE 3
PASO 3

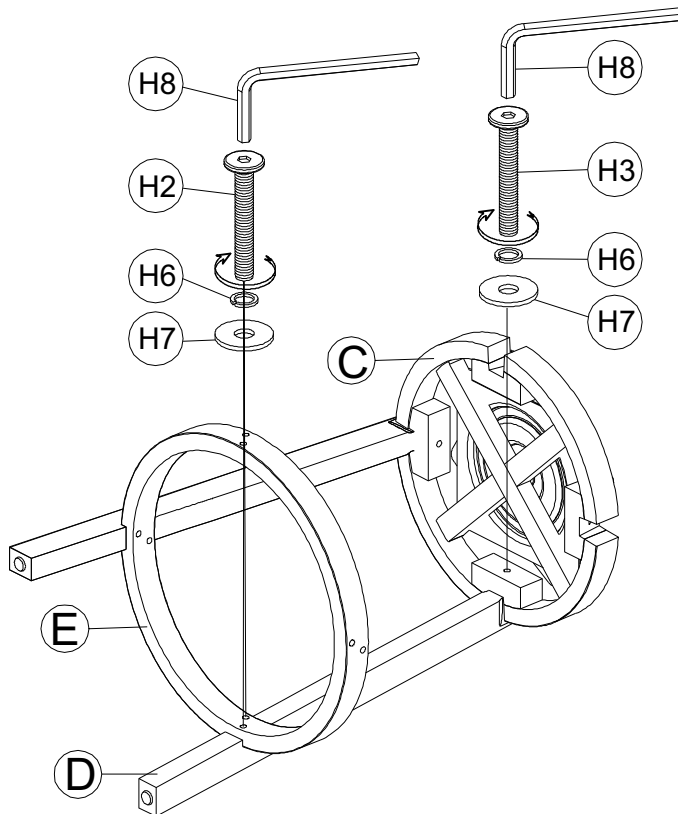

H2		2
H3		1
H6		3
H7		3
H8		1

STEP 4
ÉTAPE 4
PASO 4

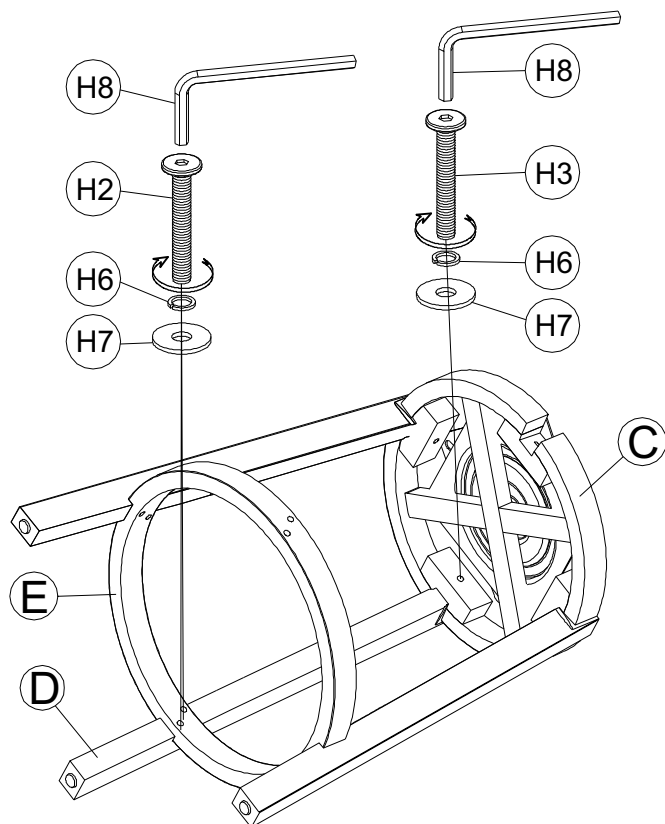

H2		2
H3		1
H6		3
H7		3
H8		1



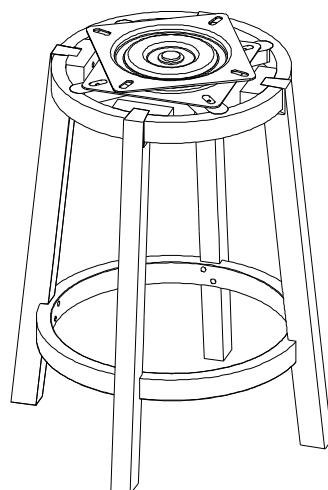
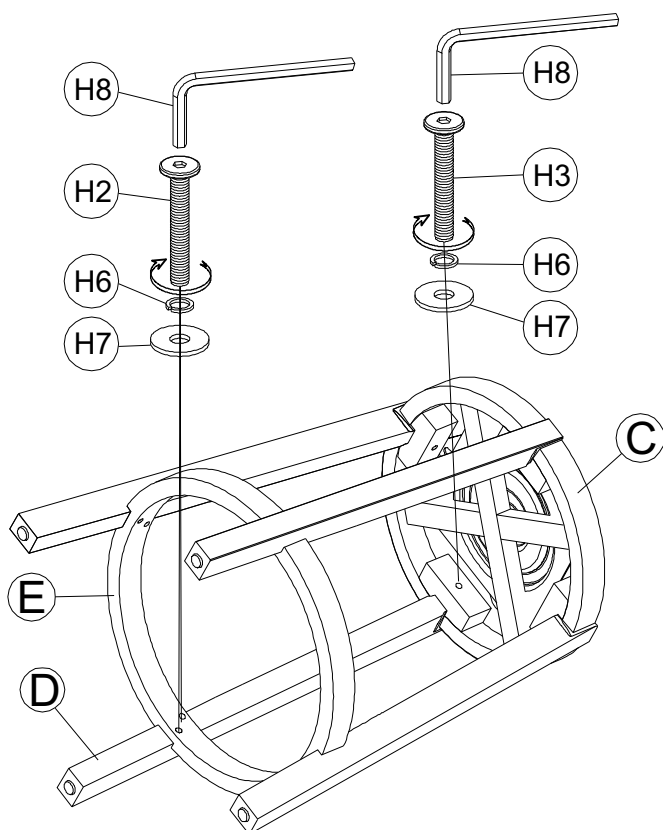

STEP 5
ÉTAPE 5
PASO 5

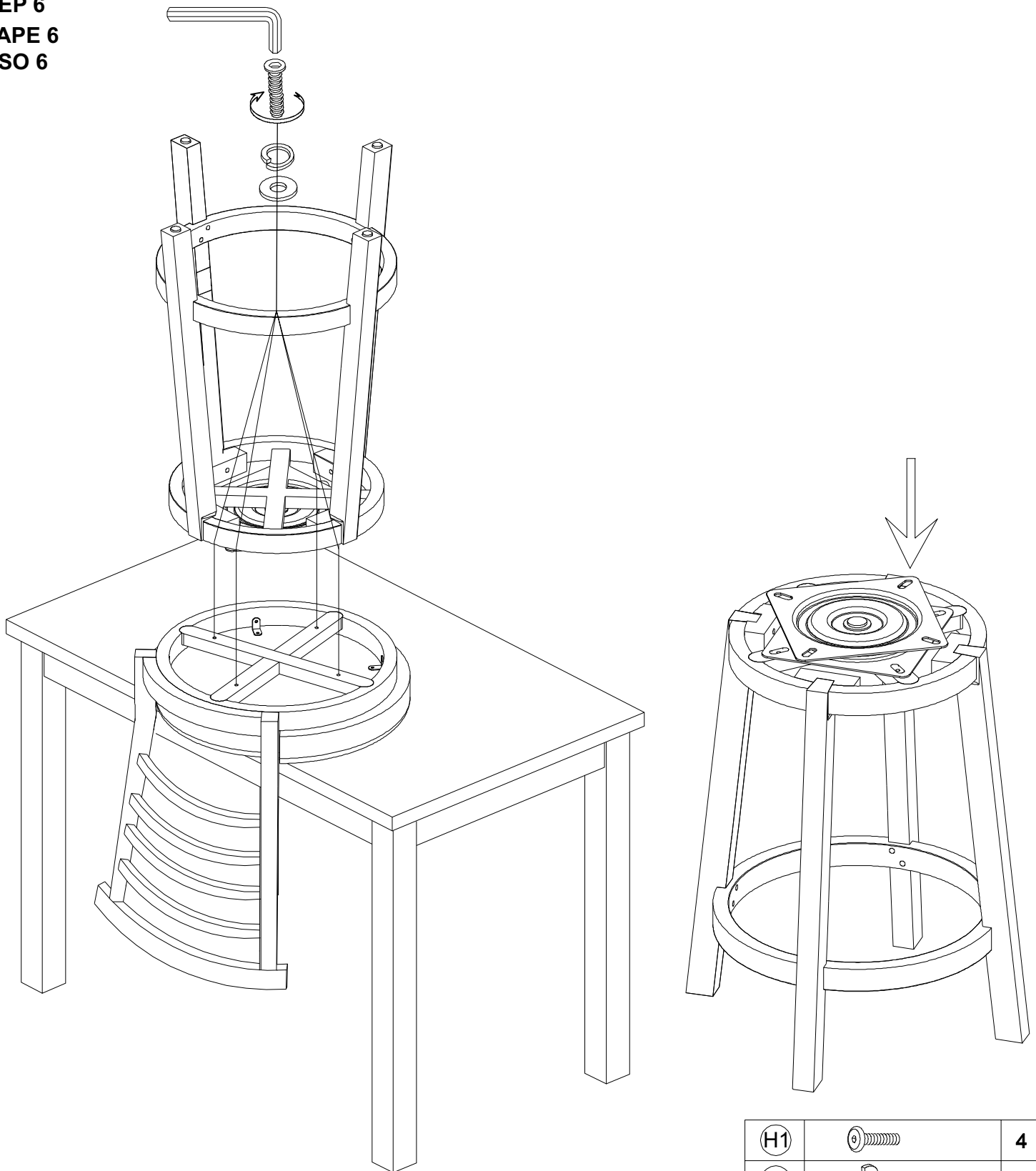

H2		2
H3		1
H6		3
H7		3
H8		1

STEP 6
ÉTAPE 6
PASO 6



H1		4
H6		4
H7		4
H8		1

STEP 7
ÉTAPE 7
PASO 7

WEIGHT LIMIT 275 LBS
POIDS MAXIMAL 275 LBS
LÍMITE DE PESO 275 LBS

