



Gourmet d'Expert[®] Electric Skillet OPERATING INSTRUCTIONS

EP-RAC50

INDEX

IMPORTANT SAFEGUARDS.....	2
PARTS NAMES.....	6
REPLACEMENT PARTS.....	6
HOW TO USE.....	7
RECIPES:	
YOSE-NABE / SHABU-SHABU.....	10
CORN RISOTTO / STEAK.....	11
STEAMED SEAFOOD / STEAMED CHOP SUEY.....	12
STEAMED CHICKEN / STEAMED VEGETABLES.....	13
CHAWAN-MUSHI / STEAMED SOUP WITH CHINESE CABBAGE AND SCALLOPS / MACCHA (GREEN TEA) STEAMED CAKE.....	14
SWEET RICE COOKED WITH MOUNTAIN VEGETABLES / CHINESE PORK DUMPLINGS.....	15
CLEANING AND MAINTENANCE.....	16
TROUBLESHOOTING GUIDE.....	17
SPECIFICATIONS.....	17

IMPORTANT SAFEGUARDS

BASIC SAFETY PRECAUTIONS SHOULD ALWAYS BE FOLLOWED WHEN USING ELECTRICAL APPLIANCES, INCLUDING THE FOLLOWING:

- 1** Read all instructions thoroughly.
- 2** This appliance is not intended for deep frying foods.
- 3** Avoid touching hot surfaces under any circumstances. The handles and knobs are provided for your safety and protection.
- 4** To prevent hazardous operation or electric shock, do not immerse power cord, power plug, or product (except flat plate, pan and lid) in water or other liquids.
- 5** Close supervision is necessary when the appliance is used by or near children.
- 6** Unplug from outlet when not in use and before cleaning. Allow the appliance to cool before adding or removing parts, and before cleaning the appliance. Make sure appliance is OFF when not in use, before putting on or taking off parts, and before cleaning.
- 7** Do not use or operate the appliance with a damaged cord or plug. If the appliance malfunctions or has been damaged in any manner, unplug the appliance and return it to the nearest authorized service facility or dealer for examination, repair or adjustment.
- 8** The use of accessories or attachments not recommended by the appliance manufacturer may be hazardous or may cause malfunction.
- 9** Do not use outdoors.
- 10** Keep the power cord away from hot surfaces and do not let the cord hang over the edge of tables or counters.
- 11** Do not place the appliance on or near a heated surface such as a gas or electric stove, or in a heated oven.
- 12** Always use extreme caution when moving appliances containing hot contents or liquids.
- 13** Plug the cord into a household electrical outlet. To disconnect, turn the power control to OFF, then remove plug from wall outlet.
- 14** Do not use the appliance for other than intended or specified purposes.
- 15** To reduce the risk of electric shock, use only the supplied flat plate and pan.
- 16** The plug to the appliance should be attached first before plugging the cord into a wall outlet.

SAVE THESE INSTRUCTIONS

THIS APPLIANCE IS FOR HOUSEHOLD USE ONLY.

This appliance is supplied with a short power cord to reduce the risk of becoming entangled in or tripping over.

This appliance has a polarized plug (one blade is wider than the other). To reduce the risk of electric shock, this plug was designed to fit into a polarized outlet in only one direction. If the plug does not fit fully into the outlet, do not attempt to force it or modify it in any way. Simply reverse the plug and insert. If it still does not fit, contact a qualified electrician.

IMPORTANTES MESURES DE SÉCURITÉ

LORS DE L'UTILISATION D'APPAREILS ÉLECTRIQUES, SUIVEZ LES PRÉCAUTIONS DE BASE SUIVANTES:

- 1** Lisez bien toutes les instructions.
- 2** Cet appareil n'est pas conçu pour la grande friture des aliments.
- 3** Ne touchez pas les surfaces qui peuvent être chaudes. Utilisez les poignées ou les boutons. N'obtenez en aucun cas l'orifice d'échappement de la vapeur.
- 4** Pour éviter les chocs électriques, n'immergez jamais le cordon électrique ou la prise, ou encore l'autocuiseur à riz (à l'exception de la marmite située à l'intérieur) dans l'eau ou dans tout autre liquide.
- 5** Soyez vigilants lorsque les enfants utilisent l'appareil ou se trouvent à proximité.
- 6** Débranchez l'appareil après usage ou avant de le nettoyer. Laissez l'appareil refroidir avant d'en retirer ou d'y insérer les accessoires et avant de le nettoyer. Assurez-vous que l'appareil est sur OFF lorsque vous ne vous en servez pas, avant d'en retirer ou d'y insérer les accessoires détachables ou encore avant de le nettoyer.
- 7** N'utilisez pas l'appareil avec une prise ou un cordon électrique endommagé. Ne vous servez pas d'un appareil qui pour une raison ou une autre fonctionne mal. Emportez l'appareil chez le réparateur ou le vendeur le plus proche en vue d'un contrôle ou d'une réparation.
- 8** L'utilisation d'accessoires non recommandés par le fabricant est susceptible d'entraîner des accidents.
- 9** N'utilisez pas l'appareil à l'extérieur.
- 10** Ne laissez pas le cordon électrique pendre par-dessus le bord d'une table ou d'un comptoir et assurez-vous qu'il n'est pas en contact avec une surface chaude.
- 11** Ne placez pas l'appareil près d'une surface chaude telle qu'un brûleur à gaz allumé, une plaque électrique, un poêle ou encore dans un four en train de chauffer.
- 12** Soyez très prudent lorsque vous déplacez l'appareil contenant un liquide ou un aliment chaud.
- 13** Branchez le cordon dans une prise domestique. Avant de débrancher l'appareil, placez-le sur la position ARRÊT puis retirez la fiche de la prise murale.
- 14** N'utilisez pas l'appareil pour d'autres fonctions que celles auxquelles il est destiné.
- 15** Pour minimiser les risques de chocs électriques, n'utilisez que la marmite interne fournie avec l'appareil.
- 16** Veuillez d'abord relier le cordon d'alimentation à l'appareil avant de brancher la fiche dans une prise murale.

CONSERVEZ CES INSTRUCTIONS

CET APPAREIL EST UNIQUEMENT À USAGE DOMESTIQUE.

L'appareil est équipé d'un cordon court afin de réduire les risques d'enchevêtrement ou de chutes sur le cordon.

L'appareil a une prise polarisée (l'une des lames est plus large que l'autre). Pour réduire les risques de chocs électriques, la prise s'insère dans un seul sens à l'intérieur d'une prise murale polarisée. Si la prise ne s'adapte pas correctement dans la prise murale, retournez-la. Si elle ne s'adapte toujours pas, contactez un électricien spécialisé. Ne cherchez en aucun cas à modifier la prise.

IMPORTANT SAFEGUARDS Be sure to follow the instructions.



● These WARNINGS and CAUTIONS are intended to protect you and others from personal injury and household damage. To ensure safe operation, please follow carefully.



 **WARNINGS** Indicates risk of serious injury. ※1



 **CAUTIONS** Indicates risk of injury or property damage if mishandled. ※2 ※3

※1 Serious injury includes loss of eyesight, burns (high and low temperature), electric shock, bone fractures, toxic reactions as well as other injuries severe enough to require medical care or extended hospitalization.

※2 Injury indicates physical damage, burns or electric shock not severe enough to require medical care or extended hospitalization.















 **CAUTIONS**  Indicates a warning or caution. A specific caution is indicated inside or near the triangle by sentences or illustrations.

 **PROHIBITED**  Indicates a prohibited operation. A specific prohibited operation is indicated inside or near the circle by sentences or illustrations.

 **INSTRUCTIONS**  Indicates a requirement or instruction that must be followed. A specific instruction is indicated inside or near the circle by sentences or illustrations.

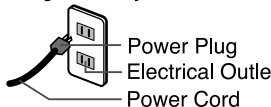









※3 Property damage indicates material damage towards a home, furniture, or pets and animals.

*Keep this Operating Instructions readily available for users to easily refer to at any time.

 WARNINGS	
 Do not modify the product. Only a repair technician may disassemble or repair this unit. Attempting to do so may cause fire, electric shock or injury. Make any repair inquiries to Zojirushi Customer Service.	 Do not allow the prongs of the Appliance Plug to become soiled with dust or come into contact with any metal objects. This may cause electric shock, short circuit or fire.
 Do not immerse the product in water or splash it with water. Doing so may cause short circuit or electric shock.	 Use only an electrical outlet rated at 15 amperes minimum, and do not plug other devices into the same outlet. Plugging other devices into the same outlet may cause the electrical outlet to overheat, resulting in fire.
 Do not plug or unplug the Power Cord if your hands are wet. Doing so may cause an electric shock or injury.	 Insert the Power Plug completely and securely into the electrical outlet. A loosely inserted Power Plug may cause electric shock, short circuit, smoke or fire.
 Do not use this product for deep frying. Doing so may cause fire.	 Stop using immediately if you notice any of the following symptoms indicating a malfunction or breakdown. Continued use of the product may cause smoke, fire, electric shock or injury. <ul style="list-style-type: none"> • The Power Plug or Power Cord has become very hot. • The Power Cord is deeply damaged or deformed. • The electricity turns on and off when the Power Cord is touched or moved. • There is a burning smell. • You feel a tingle or slight electrical shock. • The product does not operate even though the Control Lever is turned on. • The Operation Light does not turn off even though the Control Lever is turned to OFF.
 Do not use a power source other than 120V AC. Use of any other power supply voltage may cause fire or electric shock.	<p>If you notice any of the above symptoms, unplug the product immediately and contact the store where you purchased it or Zojirushi Customer Service for check-ups and/or repairs.</p>
 Do not use the product if the Power Plug or Power Cord is damaged or if the Power Plug is loosely inserted into the electrical outlet. Doing so may cause electric shock, short circuit or fire. <div style="text-align: right; margin-top: 10px;">  <p>Power Plug Electrical Outlet Power Cord</p> </div>	 This product is not intended for use by persons (including children) with reduced physical, sensory or mental capabilities, or lack of experience and knowledge, unless they have been given supervision or instruction concerning use of the appliance by a person responsible for their safety. Children should be supervised to ensure that they do not play with the appliance.
 Do not damage the Power Cord. Do not bend, pull, twist, fold, or attempt to modify the Power Cord. Do not place it on or near high temperature surfaces or appliances, under heavy items or between objects. A damaged Power Cord can cause fire or electric shock.	
 Do not allow children to use the product unsupervised. Keep it out of the reach of infants. Children are at risk of burns, electric shock or injury.	
 Do not allow infants or children to put the Appliance Plug in their mouth. Doing so may cause electric shock or injury. Take special precautions with children and infants.	



CAUTIONS

 <p>Do not touch hot surfaces during or immediately after use. Touching hot surfaces may cause burns.</p>	 <p>Do not place or use the product on unstable surfaces or on surfaces that are vulnerable to heat. Doing so may cause fire.</p>
 <p>Unplug the Power Plug from the outlet when the product is not in use. Leaving the Power Plug in an outlet may cause the insulation to become damaged, resulting in electric shock, short circuit or fire.</p>	 <p>Do not directly heat canned or bottled foods as the can or bottle may explode and cause burns or injury.</p>
 <p>Always unplug the product by holding the Power Plug, not by pulling the Power Cord. Pulling the Power Cord to unplug the product may cause electric shock, short circuit or fire.</p>	 <p>Do not use the product near walls, furniture or beneath shelving. Steam or heat may damage, discolor or deform walls, furniture or shelving.</p>
 <p>Please allow the product to cool down before cleaning. The Flat Plate and Pan may cause burns when hot.</p>	 <p>Do not use other Power Cords than the one provided. Do not use the Power Cord for other appliances. Doing so may cause malfunction or fire.</p>
 <p>During preheating or cooking, move birds and small animals that may be sensitive to smoke or smells to other rooms, and open windows or turn on exhaust fans.</p>	 <p>Do not use this product for other than intended purposes.</p>  <p>If the Power Cord is damaged, it must be replaced by an appropriate cord or assembly made available by the manufacturer or its service agent.</p>

IMPORTANT

- Do not use this product for other than stewing, grilling or steaming foods.
- Do not use the Pan to grill or sauté foods. The Pan is for cooking stew-type menus or for steaming only.
- Do not turn the power on without setting the Pan or Flat Plate in the Main Body. Doing so may cause fire.
- Do not leave the Heating Plate with foreign objects attached. It may become stuck to the plate and cause rust.
- Handle the product gently; otherwise it may cause malfunction or breakdown.
- Please follow these instructions to ensure extended use of the Pan and for the protection of the Flat Plate's nonstick coating:
 - *Do not use metal spatulas. Doing so may damage the surface.
 - *Do not scratch the Pan with sharp objects such as knives and forks.
 - *Do not preheat the Pan for an extended period of time. Do not use the Flat Plate directly on the stovetop.
 - *Do not use a thinner, benzene, abrasive cleaners and brushes (nylon/metal), bleach or anything that may damage the surface of the product. Doing so may cause deformation, discoloration or scarring of the product.
 - *Always clean the surface and the bottom of the Pan and Flat Plate thoroughly after use. Acid (vinegar) or salt contents (sauce, soy sauce or salt) may cause corrosion or the product may not perform well.
 - *Do not use detergents other than mild kitchen detergent such as chlorine based alkaline detergents or those containing acidic ingredients. Doing so may cause corrosion.
 - *Do not leave cooked foods in the Pan and Flat Plate. Doing so may cause rust.
- Please follow these instructions to avoid breakage of the glass Lid:
 - *Do not cool it down too fast.
 - *Do not drop or apply strong impact.
 - *Do not place directly on fire.
- Do not use the Flat Plate on a gas or electric stovetop burner.
Doing so may cause the nonstick coating to peel off, corrode, or cause the Flat Plate and Pan to deform or discolor.

PARTS NAMES

Cover Knob

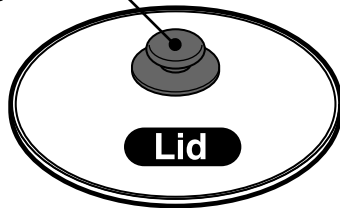

Lid

Steaming Plate

Used to steam foods.

Set in the Pan to use.
(See pg. 9 "HOW TO USE")

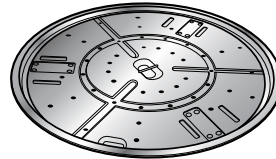

Flat Plate

Ideal for grilling and sautéing menus such as steaks, *Okonomi-Yaki* (Japanese pancake) and *Yaki-Soba* (stir-fried noodle). It is also suitable for cooking *Sukiyaki* and hot pots as it has sufficient depth.

Handle

(Located at 2 positions: right & left edge)

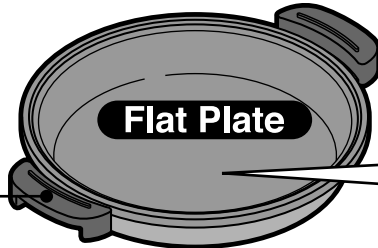

Pan

The Pan can be used directly on the stovetop to shorten precooking time.

Handle

(Located at 2 positions: right & left edge)

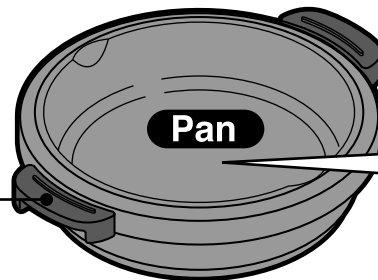

Power Cord

Power Plug

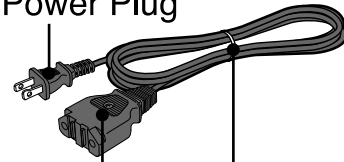

Appliance Plug

Twist Tie

Heating Plate

Plug Receptacle

Main Body

Display Panel

Control Lever

Holder

Located at the bottom edge of both sides.

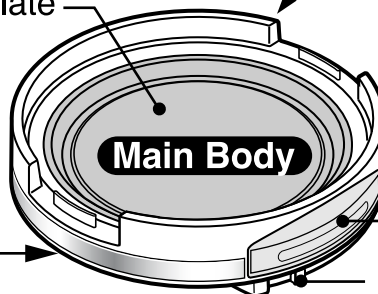

- Please remove the twist tie holding the Power Cord before use.
- Do not use the Power Cord bundled up. Doing so may cause the Power Cord to become excessively hot, resulting in malfunction.

REPLACEMENT PARTS

*Please replace damaged parts for optimum performance.

*When replacing parts, please check the model number and the parts name beforehand, then contact the store where you purchased the product or Zojirushi Customer Service.

Parts Names	Parts Number
Lid	BG347801R-00
Flat Plate	BG347803G-00
Pan	7190690000-01
Steaming Plate	7190660000-00

HOW TO USE HOW TO PREPARE

① Set the Pan or the Flat Plate on the Main Body.

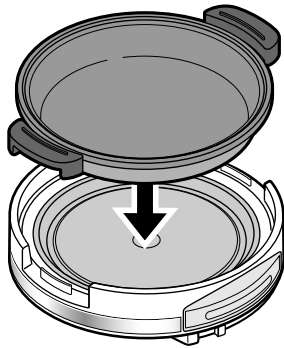

② Turn the Control Lever to OFF and plug in the Power Cord.

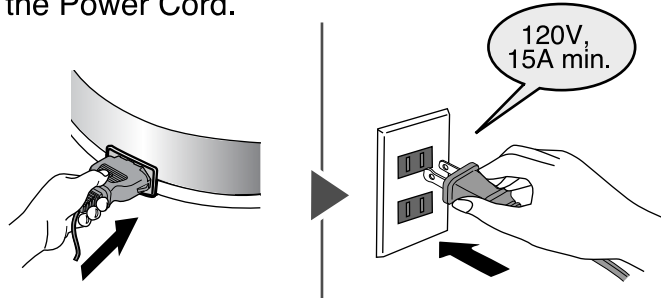

*Be sure that the Appliance Plug is clean and free from any foreign objects.

*Be sure to wipe off all moisture on the Heating Plate and on the bottom of the Flat Plate or Pan. (Moisture or water may decrease the product's ability to heat or cause malfunction.)

*Set the Flat Plate or Pan securely. Make sure it is not slanted.

*Be sure to insert the Power Plug into the electrical outlet securely.

■ Cooking Tips



Precook stew-type menus directly on the stovetop burner in the Pan:

The Pan can be used directly on the stovetop burner for quicker heating and preparation.

Do not heat the Pan empty on the stovetop burner.
(Do not use the Pan on the induction heater.)

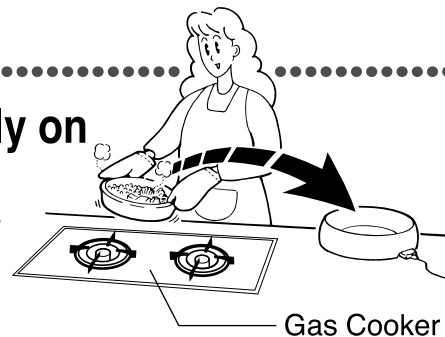

NOTE The Flat Plate **CANNOT** be used directly on the stovetop.

*Adjust the flame to the Pan size. The Handles may become burnt or deform if the flames are too strong.

*Do not use the Pan directly on the stovetop burner for other than preparing stew-type menus (such as sizzling, grilling or sautéing). Do not use the Flat Plate directly on the stovetop burner. Doing so may cause deformation or the nonstick coating to peel off or corrode.

*To prevent burns, always use oven mitts when holding the Handles as they may become hot.



Utilize the Lid:

The surface temperature of the Pan and Flat Plate can become 68-86°F higher when the Lid is covered.

*Sizzling and steaming menus (such as frying dumpling, hamburger, steak, fried egg, etc.) can be cooked faster and softer.

*Water or broth will boil faster.

Be careful when removing the Lid:

*Steam may arise from the gap between the Lid and the Pan or Flat Plate.

*Hot oil may sputter from the gap between the Lid and the Flat Plate when grilling steaks.

HOW TO USE HOW TO COOK

Control Panel

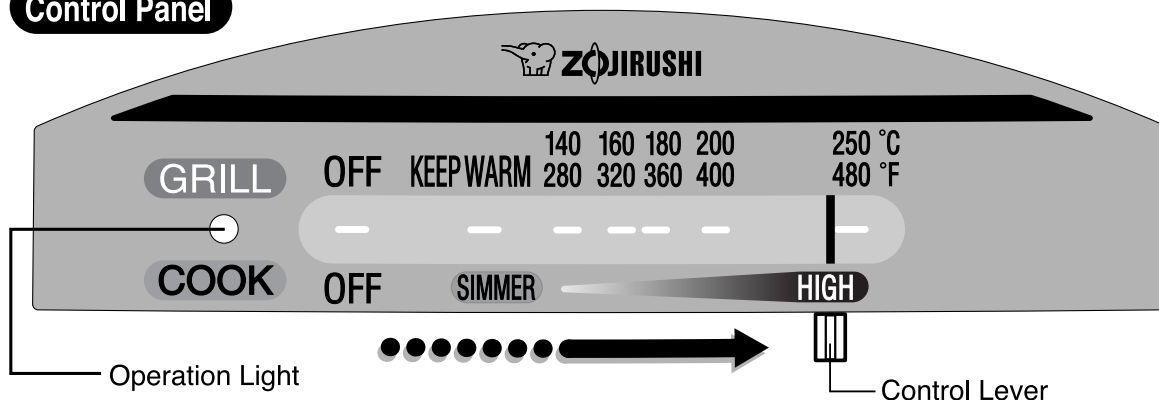

Cooking in the Pan:

Ideal for cooking hot pots or stews

- 1) Pour water or soup stock in the Pan and cover the Lid.
 - 2) Adjust the Control Lever to HIGH. The Operation Light will turn on.
 - 3) When the water or soup stock reaches a boil, add ingredients and begin cooking.
- Do not use the Pan for grilling or sautéing foods.

Power guidelines for pot and stew menus:

Power	Menus
SIMMER	<i>Yose-nabe</i> (Seafood, chicken, tofu, noodles, and vegetables cooked in stock) <i>Sukiyaki</i> <i>Shabu Shabu</i> <i>Yudofu</i> (Boiled <i>tofu</i> cooked in stock)
↑ ↓	
HIGH	<i>Oden</i> (Vegetables and fish cakes cooked in stock) <i>Stew</i>

Cooking in the Flat Plate:

Ideal for grilling and sautéing

- 1) Adjust the Control Lever to the preferred temperature and preheat. (The Operation Light will turn on and the product begins operating.)
- Do not cover the Lid when preheating.
- 2) Begin cooking when preheating completes.

Estimated preheat time:

About 6 minutes

Temperature guidelines for grilling and sautéing:

Power	Menus
480°F 250°C	<i>Yaki-niku</i> (BBQ beef), Fried noodles, Steaks and <i>Sukiyaki</i> etc.
400°F 200°C	<i>Okonomi-yaki</i> (Japanese pancakes) etc.
360°F 180°C	<i>Gyoza</i> (grilled dumplings) etc.
320°F 160°C	Pancakes etc.
280°F 140°C	Crepes, Thin omelets etc.
KEEP WARM	Keeping foods warm at the optimum temperature

*The above temperatures are estimated surface temperatures of the Flat Plate when uncovered.

- Use hot water (not water) to steam and finish grilling *Gyoza* (grilled dumplings).
- When keeping food warm, turn the Control Lever to KEEP WARM.
- You may hear some noise or small clicking sounds during use. This is due to the expansion of the Main Body by the heat and does not indicate a malfunction.

- You may notice that the Operation Light turns on and off during preheat and cooking. This is due to the product controlling the temperature and does not indicate a malfunction.
- You may notice some smell or smoke emitting from the product at initial use, but this is normal and does not indicate a malfunction.

Steaming in the Pan with the Steaming Plate:

- 1) Pour water or hot water in the Pan.
 - Refer to the chart on the right for suggested amounts of water.
 - The time in the chart is the boiling time at the HIGH setting.
- 2) Set the Steaming Plate.
 - Adjust the height of the Steaming Plate's Legs (3 locations) depending on the amount of water.
- 3) Place foods on the Steaming Plate and cover the Lid.
- 4) Adjust the Control Lever to HIGH. The Operation Light will turn on.

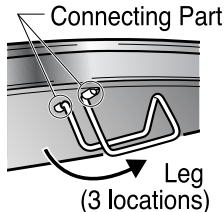
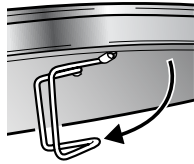
Boiling Time:	max. 20 minutes	max. 40 minutes
Water Amount:	about 3-1/2 cups	about 6-1/4 cups
Height of the Steaming Plate:	Low	High
		
Menu:	To steam seafood, chicken, steamed vegetables, dumplings, steamed cakes, etc.	To cook sweet rice, etc.

NOTES

- *Be careful of hot steam when opening the Lid during cooking.
- *Do not pour water or hot water above the Water Limit Hole, indicated by the arrow imprinted on the Steaming Plate. Water filled above the Water Limit Hole may result in unsatisfactory cooking.
- *Allow the Steaming Plate to cool before removing it, and use the Carrying Handle.

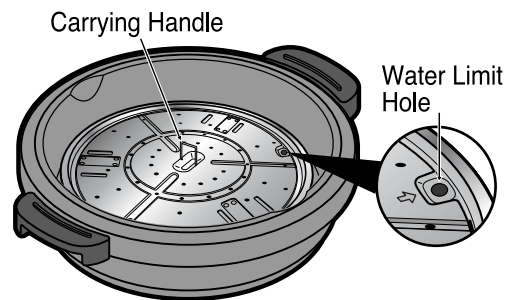

- *If using a bowl or container to steam, limit the height to 2 inches when the Steaming Plate is set at "Low" and 1-1/2 inches when set at "High".
- *If the water evaporates during steaming, white or light brown colored powdery objects may be found on the Pan. This is due to the ingredients in the water and does not indicate discoloration or corrosion of the Pan. It is also harmless to your health, but always clean the Pan after use.

AFTER USE...

- 1) Turn the Control Lever to OFF.
- 2) Unplug the Power Plug and the Appliance Plug.

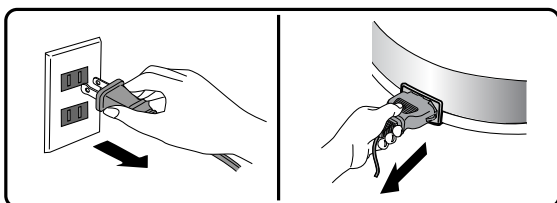

- *Be sure to unplug the product by holding the Power Plug, not by pulling the Power Cord.
- *Be sure to unplug the Power Cord after every use.
- *Please allow the product to cool down before cleaning (for about 40 minutes after cooking).

RECIPES

NOTE

The measurements used in these Recipes:

- 1 Cup = approx. 8 oz.
- 1 Tablespoon = 0.5 oz.
- 1 teaspoon = 0.2 oz.

Recipes to Cook in the Pan

YOSE-NABE

HIGH ~ SIMMER



Ingredients (4 servings):

- | | |
|---|---|
| 4 small crabs | 8 pieces <i>Yaki-fu</i> (baked Japanese dry wheat gluten) |
| 8 scallops | 8 cups water |
| 2 white fish fillets | 1 sheet <i>Konbu</i> (kelp), approx. 4" x 4" |
| 1/2 lb. chicken | Seasoning: |
| 2 packs tofu (firm) | Grated <i>Daikon</i> radish, green onions (sliced thinly and soaked in water) and red pepper to taste |
| 4 stalks green onions (or welsh onions) | Ponzu sauce: |
| 1 carrot | (seasoned soy sauce with citrus juice, available in Asian markets) to taste |
| 1 bunch <i>Shungiku</i> (garland chrysanthemum) | |
| 1 pack <i>Enokidake</i> (winter mushroom) | |
| 1 block <i>Konnyaku</i> | |
| 1/2 pack <i>Harusame</i> (vermicelli) | |
| 8 <i>Ginnan</i> (ginkgo nut) in a can | |

How to cook:

- 1) Cut fish fillet and chicken into bite-size pieces. Cut tofu into large blocks. Thinly slice green onions diagonally, thinly slice carrots, cut *Shungiku* into 1-1/2 to 2 inches width and cut off the hard part at the bottom of *Enokidake*. Thinly slice *Konnyaku* and run it through boiling water. Soak *Harusame* and *Yaki-fu* in water to soften and drain.
 - 2) Add water and *Konbu* in the Pan, cover the Lid and turn the Control Lever to **HIGH**.
 - 3) Remove the *Konbu* from the Pan right before the water begins to boil, then add crabs. When it begins to boil again, add the remaining ingredients. Once the ingredients are cooked through, dip them in the seasoning and *Ponzu* sauce to enjoy.
- *Adjust the Control Lever between **HIGH** and **SIMMER** to change the cooking temperature.

SHABU-SHABU

HIGH ~ SIMMER



Ingredients (4 servings):

- 8 cups water
 - 1 to 1-1/2 lbs. beef or pork, thinly sliced
 - Shabu-Shabu* sauce (available in Asian markets)
- Other ingredient options:**
- Green onions (or welsh onion)
 - Chinese cabbage
 - Fresh *Shiitake* mushrooms
 - Shirataki* (*Konnyaku* noodles)

How to cook:

- 1) Thinly slice green onions diagonally and cut Chinese cabbage into 1-1/2 to 2 inches strips. Cut off the hard part at the bottom of the *Shiitake* mushrooms. Run *Shirataki* in boiling water and cut into 3-4 inches length.
 - 2) Add water in the Pan, cover the Lid and turn the Control Lever to **HIGH**.
 - 3) Once the water begins to boil, add some of the vegetables, and when it begins to boil again, take a slice of the meat and swirl it in the boiling water to cook. Dip in the *Shabu-Shabu* sauce to enjoy.
- *Adjust the power between **HIGH** and **SIMMER** to change the cooking temperature.

RECIPES Cont.

Recipes to Cook in the Flat Plate

CORN RISOTTO

HIGH ~ **SIMMER**



Ingredients (2-3 servings):

- 5-1/2 oz. long grain rice
 - 1/4 brown onion
 - 1 cup corn (canned or frozen)
 - 3 cups soup stock (chicken broth, etc.)
 - Salt and pepper
 - Olive oil
 - 2 tsp. chopped parsley
 - 2-5 Tbsp. grated parmesan cheese
- ☆Indica rice (long grain) is ideal for this menu.

How to cook:

- 1) Rinse rice and drain. Finely chop onion.
- 2) Turn the Control Lever to **HIGH**. When preheating completes, add olive oil and stir-fry the onions from Step 1 above and then the rice.
- 3) When the rice turns translucent, add the soup stock and cover the Lid. Turn the Control Lever to **SIMMER** once it begins to boil.
- 4) After about 15 minutes, add corn and turn the Control Lever to **HIGH** again. When it reaches a boil, add salt and pepper to taste.
- 5) Serve in a bowl and garnish with parsley and grated cheese.

STEAK

480°F (250°C)



Ingredients (4 servings):

- 4 cuts sirloin or fillet steak
- Salt and pepper
- Vegetable oil
- ◆Garlic slices (optional)

Garnish:

- Carrots, potatoes, kidney beans
- (Broccoli and cauliflower also make great garnishes)

How to cook:

- 1) Prepare the garnish first by boiling the carrots, potatoes and kidney beans.
- 2) Turn the Control Lever to **480°F(250°C)**. When preheating completes, heat vegetable oil. Toast garlic slices until they turn golden brown and reserve. Flavor the steak with salt and pepper and place on the Flat Plate. Once the steak becomes golden brown, turn it over and cover the Lid.
- 3) Grill the meat until your preferred finish. Serve on a warmed plate along with the garnish. Garnish steak with roasted garlic.

*Be careful when uncovering the Lid during cooking as oil may sputter.

RECIPES Cont.

Recipes to Steam in the Pan using the Steaming Plate

STEAMED SEAFOOD

◇ This recipe is ideal to cook at-the-table for everyone to enjoy.

HIGH Steaming Plate:
Low

Ingredients (4 servings): ● This recipe uses a heat-resistant plate (approx. 10 inches in diameter and 1-1/2 inches in depth)

4 clams (in the shell)
4 scallops
4 prawns, peeled and deveined
1 white fish fillet
1 squid (approx. 3-1/2 oz.)
2-1/2 oz. seaweed (soaked in water and softened)
1 leaf Chinese cabbage
Kuko (Chinese matrimony vine, soaked in warm water and softened) to taste

Dipping sauce:

Melted butter and lemon juice

How to cook:

- 1) Cut fish, squid and seaweed into bite-size pieces. Boil Chinese cabbage and cut vertically into 4 strips. Roll the Chinese cabbage from one end and decorate with *Kuko* on top.
- 2) Lay the seaweed on a heat-resistant plate and arrange the seafood and Chinese cabbage on top.
- 3) Add 2-1/2 cups of water in the Pan and place the Steaming Plate with its Legs at the **Low** position.
- 4) Place the heat-resistant plate from Step 2 on the Steaming Plate and cover the Lid.
- 5) Turn the Control Lever to **HIGH** and allow to steam for 8-10 minutes after it reaches a boil (when steam comes out from the gap between the Pan and the Lid).
- 6) Upon completion, turn the Control Lever to **OFF**. Dip in melted butter and lemon juice to enjoy.



STEAMED CHOP SUEY (with Chinese pork dumplings)

◇ This recipe is ideal to cook at-the-table for everyone to enjoy.

HIGH Steaming Plate:
Low

Ingredients (4 servings):

● This recipe uses a heat-resistant plate (approx. 10 inches in diameter and 1-1/2 inches in depth)

A)	B)
4 Chinese pork dumplings	1 Tbsp. sake
4 prawns, peeled and deveined	1 tsp. soy sauce
1 squid (approx. 3-1/2 oz.)	3 tsp. chicken bouillon
1 leaf Chinese cabbage	1/2 Tbsp. sugar
4 leaves <i>bok choy</i> (spinach-like vegetable)	1 tsp. sesame oil
1/4 carrot	C)
2 oz. bamboo shoot	1-1/2 Tbsp. potato starch
1-1/2 oz. <i>Shimeji</i> mushroom	2 Tbsp. water
	Green onions (or welsch onions), thinly sliced, to taste

How to cook:

- 1) Cut squid into bite-size pieces. Cut Chinese cabbage and *bok choy* into bite-size pieces, and carrot and bamboo shoot into rectangles. Cut off the hard part at the bottom of the *Shimeji* mushroom and separate the bunch.
- 2) In a separate bowl, mix ingredients from (B) well. Toss all ingredients from (A) on a heat-resistant plate, and pour the mixture (B) on top.
- 3) Add 3 cups of water in the Pan and place the Steaming Plate with its Legs at the **Low** position.
- 4) Place the heat-resistant plate from Step 2 on the Steaming Plate and cover the Lid.
- 5) Turn the Control Lever to **HIGH** and allow to steam for about 15 minutes after it reaches a boil (when steam comes out from the gap between the Pan and the Lid).
- 6) Upon completion, turn the Control Lever to **OFF**.
- 7) In a small bowl, mix ingredients from (C) well, and slowly mix into the plate from Step 5 to thicken. Garnish with green onions and serve.

RECIPES Cont.

STEAMED CHICKEN

◇ This recipe is ideal to cook at-the-table for everyone to enjoy.

HIGH Steaming Plate:
Low

Ingredients (3-4 servings):

- This recipe uses a heat-resistant plate (approx. 10 inches in diameter and 1-1/2 inches in depth)

2 chicken breasts (approx. 1 lb.)
1 Tbsp. sake
1 leaf cabbage
1/2 stalk green onion (or welsh onion)
1 chunk ginger
Sesame sauce to taste

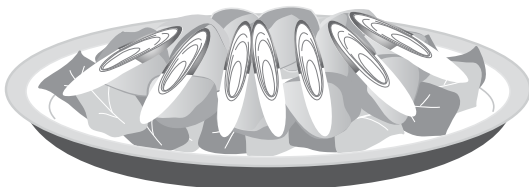

How to cook:

- 1) Cut chicken breasts into 1/2 inch strips and sprinkle with sake. Cut the cabbage into 2-inch squares, thinly slice green onions diagonally and julienne ginger.
- 2) Lay the cabbage on a heat-resistant plate and place chicken, green onion and ginger from Step 1 on top.
- 3) Add 3 cups of water in the Pan and place the Steaming Plate with its Legs at the **Low** position.
- 4) Place the heat-resistant plate from Step 2 on the Steaming Plate then cover the Lid.
- 5) Turn the Control Lever to **HIGH** and steam for 15-20 minutes after it reaches a boil (when steam comes out from the gap between the Pan and the Lid).
- 6) Upon completion, turn the Control Lever to **OFF**. Dip in the sesame sauce and serve.

STEAMED VEGETABLES

◇ This recipe is ideal to cook at-the-table for everyone to enjoy.

HIGH Steaming Plate:
Low

Ingredients (4 servings):

- This recipe uses a heat-resistant plate (approx. 10 inches in diameter)

A)	Yogurt sauce:
1/2 bunch broccoli	1 cup plain yogurt
1/4 carrot	2 tsp. mustard
4-1/2 oz. pumpkin	1 tsp. sugar
1 eggplant	1 tsp. vinegar
2 fresh <i>Shiitake</i> mushrooms	Salt to taste
Salt	

How to cook:

- 1) Wash vegetables well. Divide the broccoli into small bunches, cut eggplant into bite-size pieces and soak in lightly salted water. Thinly slice carrot and pumpkin and cut off the hard part at the bottom of the *Shiitake* mushrooms and cut in half.
- 2) Place the ingredients from (A) on a heat-resistant plate and sprinkle with salt to taste.
- 3) Add 2-1/2 cups of water in the Pan and place the

Steaming Plate with its Legs at the **Low** position and cover the Lid.

- 4) Turn the Control Lever to **HIGH** and once it reaches a boil (when steam comes out from the gap between the Pan and the Lid), place the heat-resistant plate from Step 2 on the Steaming Plate (be careful of the steam), and steam for about 10 minutes.
- 5) In a separate bowl, mix all ingredients for the yogurt sauce.
- 6) Upon completion, turn the Control Lever to **OFF** and serve with the yogurt sauce.

*This dish can also be served wrapped in ham.



RECIPES Cont.

Recipes to Steam in the Pan using the Steaming Plate

CHAWAN-MUSHI (STEAMED EGG CUSTARD)

Ingredients

(5 servings):

HIGH ~ GRILL
280°F (140°C) Steaming Plate:
Low

● This recipe uses 5 heat-resistant bowls (approx. 3-1/2 inches in diameter and 2 inches in depth)

- | | |
|-----------------------------|-------------------------------|
| 4 eggs | 1/4 lb. chicken |
| A) | 5 slices <i>Kamaboko</i> |
| 2-1/2 cups stock | (boiled fish paste) |
| 1/2 tsp. light soy sauce | 5 small fresh <i>Shiitake</i> |
| 2 Tbsp. <i>Mirin</i> (sweet | mushrooms |
| cooking sake) | 5 <i>Ginnan</i> (ginkgo nut) |
| 1/2 tsp. salt | in a can |
| B) | 1/4 bunch <i>Mitsuba</i> |
| 5 prawns, peeled and | (stone parsley) |
| deveined | |

How to cook:

- 1) Beat eggs but do not whip. Mix in ingredients from (A) and strain.
- 2) Cut chicken into bite-size pieces and cut off the hard part at the bottom of the *Shiitake* mushrooms.
- 3) Place ingredients from (B) in the heat-resistant bowls, pour egg mixture from Step 1 and cover with a plastic wrap.
- 4) Add 3 cups of water in the Pan and place the Steaming Plate with its Legs at the **Low** position.
- 5) Place the heat-resistant bowls from Step (3) on the Steaming Plate and cover the Lid.
- 6) Turn the Control Lever to **HIGH** and when it reaches a boil (when steam comes out from the gap between the Pan and the Lid), turn the Lever to **GRILL 280°F (140°C)** and steam for 20-25 minutes.
- 7) Upon completion, turn the Control Lever to **OFF**.
*When removing the plate, please use oven mitts as it will become very hot.

STEAMED SOUP WITH CHINESE CABBAGE AND SCALLOPS

Ingredients

(5 servings):

HIGH Steaming Plate:
Low

● This recipe uses 5 heat-resistant bowls (approx. 3-1/2 inches in diameter and 2 inches in depth)

- | | |
|-------------------------------|----------------------------|
| 1 leaf Chinese | <i>Shiitake</i> mushrooms) |
| cabbage | 3 tsp. chicken |
| 3 dried scallops | bouillon |
| 2 small dried <i>Shiitake</i> | Salt and pepper to |
| mushrooms (soaked | taste |
| in water and softened) | 10 <i>Kuko</i> (Chinese |
| A) | matrimony vine, |
| 3-1/2 cups water | soaked in warm |
| (including water used | water and softened) |
| to soften scallops and | |

How to cook:

- 1) Cut Chinese cabbage into bite-size pieces. Soak scallops overnight in water to soften and shred. Reserve the water used to soften the dried scallops and *Shiitake* mushrooms.
- 2) Mix ingredients from (A) well.
- 3) Place Chinese cabbage, scallops and *Shiitake* mushrooms in the heat-resistant bowls, pour mixture from Step (2) and cover with a plastic wrap.
- 4) Add 3 cups of water in the Pan and place the Steaming Plate with its Legs at the **Low** position.
- 5) Place the heat-resistant bowls from Step (3) on the Steaming Plate and cover the Lid.
- 6) Turn the Control Lever to **HIGH** and steam for 20-25 minutes once it reaches a boil (when steam comes out from the gap between the Pan and the Lid).
- 7) Upon completion, turn the Control Lever to **OFF**. Add *Kuko* in the soup and serve.
*When removing the plate, please use oven mitts as it will become very hot.

MACCHA (GREEN TEA) STEAMED CAKE

Ingredients

(10 pieces):
● This recipe uses 3 inches size
Madeleine pans

- 7 oz. pancake mix
- 1 large egg
- 3/4 cup milk
- 3 Tbsp. sugar
- 2 tsp. *Maccha* (powdered green tea)



How to cook:

HIGH Steaming Plate:
Low

- 1) Beat eggs in a bowl and whip together with milk and sugar with a whisk.
- 2) Add pancake mix and *Maccha* in (1) and mix.
- 3) Pour the mixture from Step 2 into Madeleine pans and fill up to 80%.
- 4) Add 3 cups of water in the Pan and place the Steaming Plate with its Legs at the **Low** position.
- 5) Place the Madeleine pans from Step 3 on the Steaming Plate then cover the Lid.
- 6) Turn the Control Lever to **HIGH** and allow to steam for about 15 minutes after it reaches a boil (when steam comes out from the gap between the Pan and the Lid).
- 7) Upon completion, turn the Control Lever to **OFF**.

RECIPES Cont.

SWEET RICE COOKED WITH MOUNTAIN VEGETABLES

HIGH Steaming Plate:
High



Ingredients (4 servings):

2 cups sweet rice	1 Tbsp. light soy sauce
5-1/2 oz. boiled assorted mountain vegetables	1 Tbsp. sugar
A)	1 Tbsp. <i>Mirin</i> (sweet cooking sake)
5 oz. soup stock	1/4 tsp. salt

How to cook:

- 1) Rinse sweet rice and soak in water over night. Allow to drain for 30 minutes before steaming.
- 2) Place (A) and the mountain vegetables in a saucepan and bring to a boil. Separate the mountain vegetable from the broth using a strainer. Reserve the broth.
- 3) Add 6 cups of water in the Pan and place the Steaming Plate with its Legs at the **High** position.
- 4) Place a steaming cloth (or cheesecloth) on the Steaming Plate. Place the drained sweet rice on the cloth in a doughnut shape and cover with another steaming cloth. Cover the Lid.
- 5) Turn the Control Lever to **HIGH** and allow to steam for 20-25 minutes after it reaches a boil (when steam comes out from the gap between the Pan and the Lid). Sprinkle some water on the rice about 15 minutes after it begins to boil.
- 6) Upon completion, turn the Control Lever to **OFF**. Mix the cooked sweet rice and the broth from Step (2) in a bowl.
- 7) Place the sweet rice back onto the steaming cloth on the Steaming Plate and place the mountain vegetable from Step (2) on top. Cover the Lid.
- 8) Turn the Control Lever to **HIGH** and allow to steam for about 10 minutes after it reaches a boil (when steam comes out from the gap between the Pan and the Lid).
- 9) Upon completion, turn the Control Lever to **OFF**. Place in a bowl and mix well before serving.

CHINESE PORK DUMPLINGS

Ingredients (30 pieces):

HIGH Steaming Plate:
Low

1/2 lb. ground pork	1/2 tsp. salt
3/4 small onion	30 wonton skins (available in Asian markets)
1 stalk green onion	4 oz. Chinese cabbage (cut into 2 inches wide strips)
2 dried <i>Shiitake</i> mushrooms (soaked in water and softened)	

Ponzu sauce

(seasoned soy sauce with citrus juice, available in Asian markets) to taste

A)

- 1 tsp. grated ginger
- 1 Tbsp. potato starch
- 2 tsp. sake
- 1-1/2 tsp. sugar
- 1-1/2 tsp. soy sauce
- 1-1/2 tsp. sesame oil

How to cook:

- 1) Finely chop onion, green onion and *Shiitake*.
- 2) Mix ground pork, vegetables from Step (1) and (A) and mix well.
- 3) Divide ingredients from Step (2) into 30 equal portions and wrap with the wonton skin. (Make a circle with your left thumb and index finger, place wonton skin and filling and wrap the filling.)
- 4) Add 3 cups of water in the Pan and place the Steaming Plate with its Legs at the **Low** position.
- 5) Place the Chinese cabbage on the Steaming Plate and place the dumplings from Step (3) on top, and cover the Lid.
- 6) Turn the Control Lever to **HIGH** and once it reaches a boil (when steam comes out from the gap between the Pan and the Lid), steam for about 15 minutes.
- 7) Upon completion, turn the Control Lever to **OFF** and serve with the *Ponzu* sauce.
*If steaming consecutively, add more water (about 2 to 2-1/2 cups). Make sure not to add water above the Water Limit Hole.

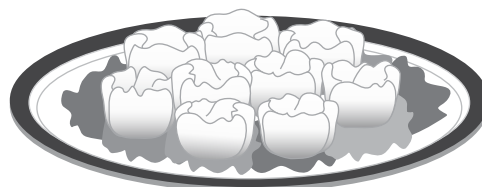

CLEANING AND MAINTENANCE

Be sure to clean thoroughly after every use. Leaving burnt foods on the Pan or the Flat Plate may cause scorching, and will become difficult to remove.

● Be sure to unplug the Power Plug and allow the Product to cool down before cleaning.

<p>Lid Flat Plate Pan Steaming Plate</p>	<p>1) Wash with a soft sponge. To wash thoroughly, use a mild kitchen detergent. 2) Wipe clean with a dry cloth after rinsing. *Allow the plate, Pan and Cover to be cooled down before cleaning. *Soak the Pan in warm water if food becomes stuck, then wash with a soft sponge. *Rinse the Lid thoroughly to ensure that there is no kitchen detergent remaining. The Lid may discolor if alkaline-based detergent is used. *After cleaning the Flat Plate, wipe thoroughly with a dry cloth, set in the Main Body and turn the power on to allow it to dry completely. Be sure not to overheat the Flat Plate. After the surface of the Flat Plate is completely dry, apply a thin layer of vegetable oil to protect the surface. *Dry the Steaming Plate thoroughly with a dry cloth, especially at its Leg's Joint Parts to prevent rusting.</p>
<p>Heating Plate</p>	<p>Soak a cloth in hot water, wring out all excess moisture, and wipe clean. *If any objects are stuck to the Heating Plate, lightly polish them off with sand paper of about No.400 after dipping in water. *Do not splash it with water or soak in water. Doing so may cause breakdown.</p>
<p>Main Body</p>	<p>Clean and wipe with a cloth soaked in water and wrung well.</p>
<p>Power Cord (Appliance Plug · Power Plug)</p>	<p>Wipe it clean with a soft dry cloth.</p>

Do not use the following:

- *Dishwasher (Doing so may cause discoloration)
- *Abrasive cleaners, scouring powders, nylon or steel brushes (These may cause deformation, discoloration and scratches)
- *Detergents other than mild dish liquid such as chlorine based alkaline detergents or acidic detergents (They may cause corrosion)

Wipe thoroughly with a dry cloth after every cleaning.

How to Store the Product

Place the Flat Plate on the Pan, making sure that the Handles overlap, and place a soft material such as a cloth in between. The Flat Plate may become damaged if the Handles are not overlapping.

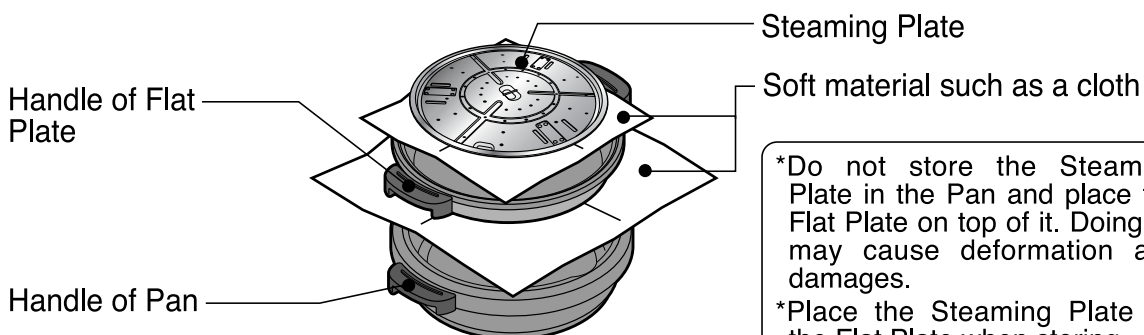

- *Do not store the Steaming Plate in the Pan and place the Flat Plate on top of it. Doing so may cause deformation and damages.
- *Place the Steaming Plate on the Flat Plate when storing.

TROUBLESHOOTING GUIDE

Please check the following points before calling for service.

Problems	●Cause (Points to check)
The Pan or Flat Plate does not get warm (power does not turn on).	*The Power Plug is not plugged in. → Connect the Power Plug.
	*The Appliance Plug is not connected properly. → Connect the Appliance Plug properly.
Does not cook well.	*Preheating was insufficient. → Preheat well before beginning to cook (approx. 6 minutes).
It takes too long to boil or it does not boil.	*Water or broth was boiled without covering the Lid. → Covering the Lid when cooking helps liquids come to a boil quicker.
	*The temperature of the water or broth was lowered by adding too much ingredients at one time. → Add ingredients gradually.
	*Heating the water or broth directly on a stovetop burner will take less time.
	*The Heating Plate is soiled, and heat is not conducting well to the Pan. → Clean the Heating Plate. (See pg. 16 "CLEANING AND MAINTENANCE")
Food scorches or burns too much.	*The Pan or Flat Plate is soiled (food is stuck on its surface). → Clean the Pan or Flat Plate. (See pg. 16 "CLEANING AND MAINTENANCE")

SPECIFICATIONS

Model No.	EP-RAC50
Rating	AC120V 1,350W 60Hz
Length of the Power Cord	6.3 feet (1.9m)
External Dimensions (approx. inches)	With the Pan : 17-1/2(W)×15(D)×8-1/8(H) With the Flat Plate: 17-1/2(W)×15(D)×6-15/16(H)
Weight	approx. 13.0 lbs.
Temperature Control	Keep Warm ~480°F (250°C)



www.zojirushi.com

EP-RAC (F)(E)(D)