

ASSEMBLY INSTRUCTIONS

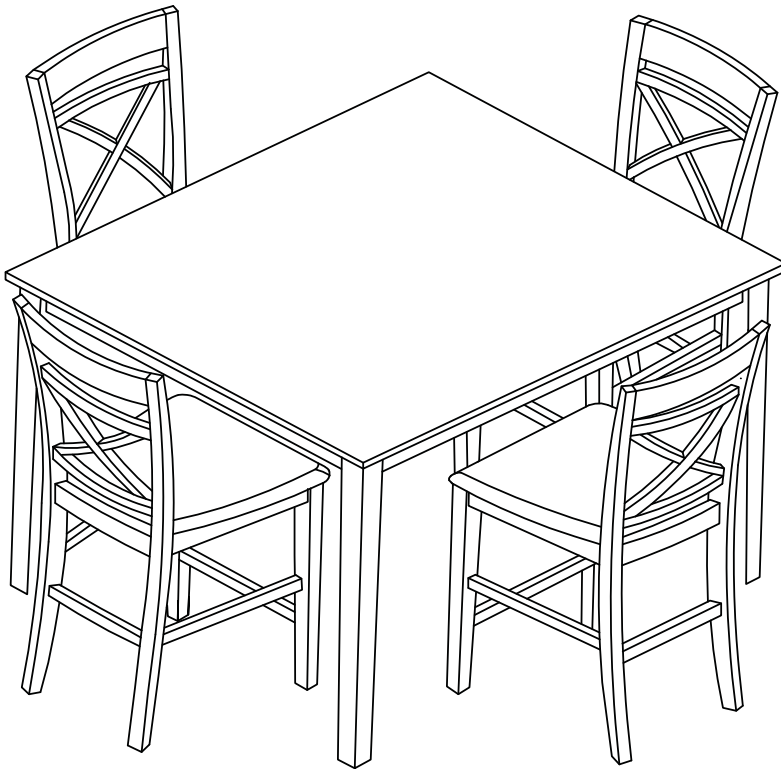

TOOLS REQUIRED



Allen Wrench

(Included)



Philips Screwdriver

(Not Included)



2 - People
Recommended

ASSEMBLY RATING

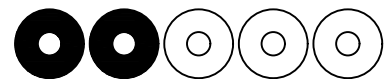

EASY —————> DIFFICULT

The Assembly Rating is a 5-point system showing the level of effort needed to assemble a specific product.

Table

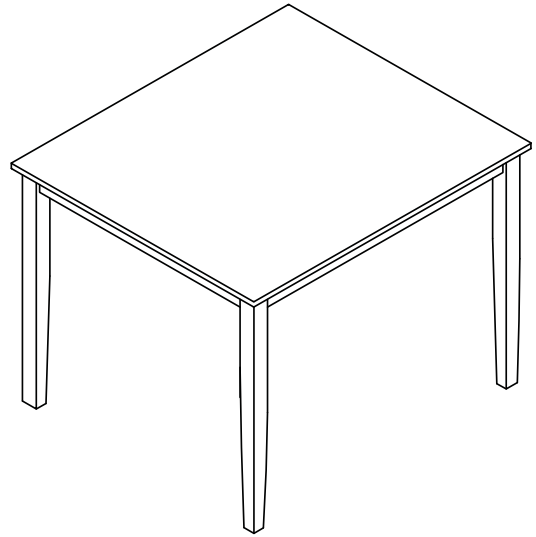
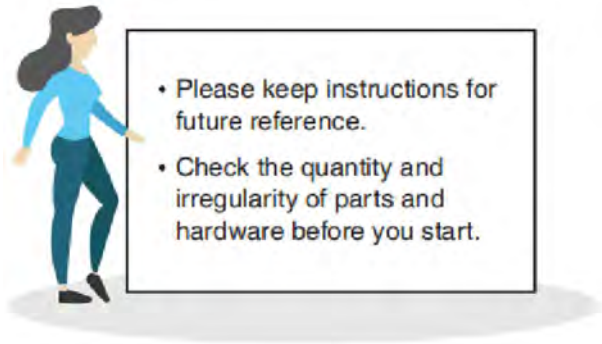

PARTS

#1 1pc

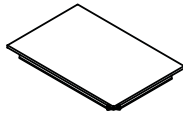

Table Top

#2 4pcs



Table Leg

HARDWARE

#A 8pcs



Bolt $\text{\O} 5/16'' \times 2-3/8''$

#B 8pcs



Lock Washer $\text{\O} 5/16''$

#C 8pcs

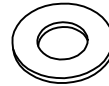

Flat Washer $\text{\O} 5/16''$

#D 1pc



Allen Wrench

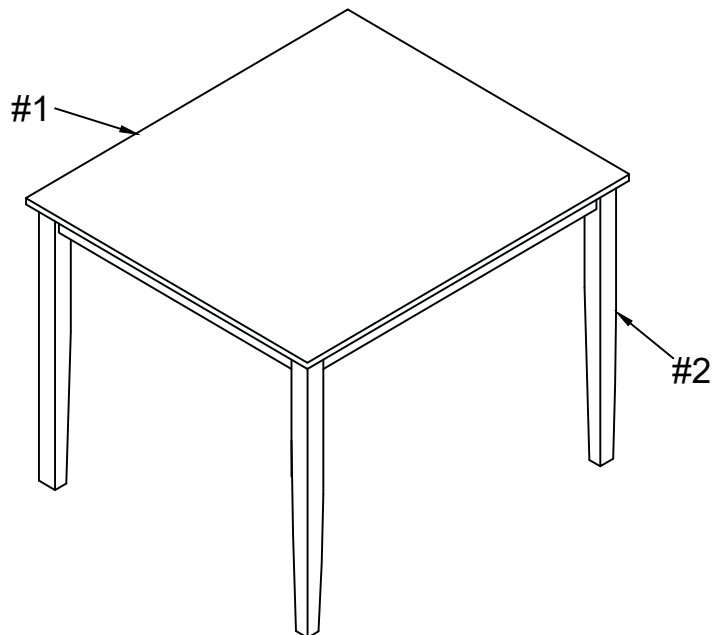

ASSEMBLY INSTRUCTIONS

1

Part #1 x1pc

Part #2 x4pcs

Hardware #A x8pcs

Hardware #B x8pcs

Hardware #C x8pcs

Align legs (#2) to the top (#1), then secure by using bolts (#A) with washer (#B,C).

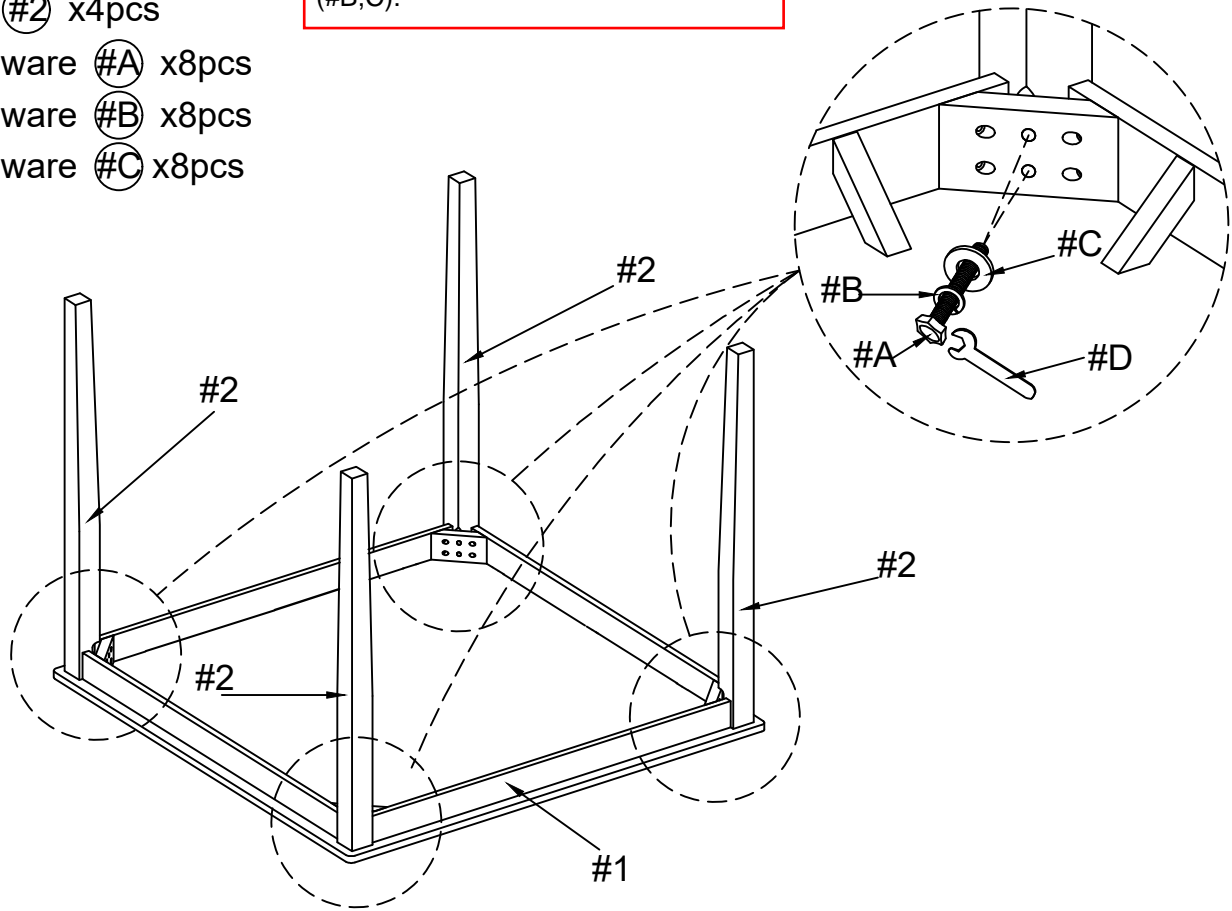

2

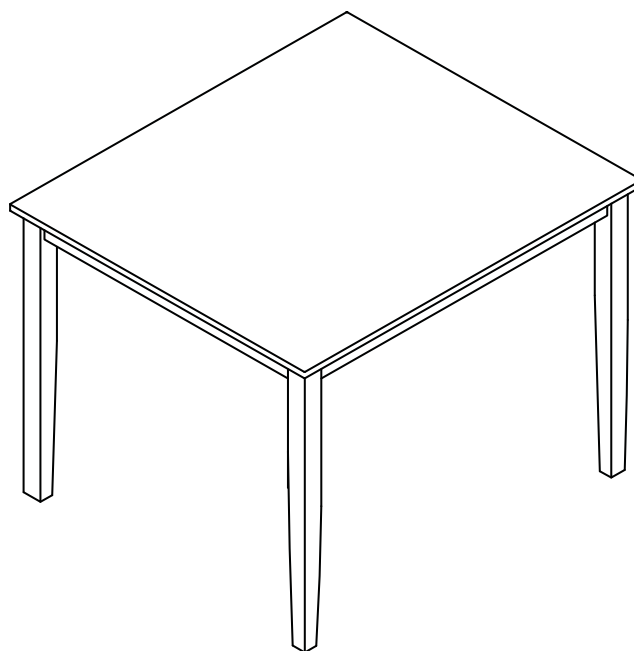

Chair



- Please keep instructions for future reference.
- Check the quantity and irregularity of parts and hardware before you start.

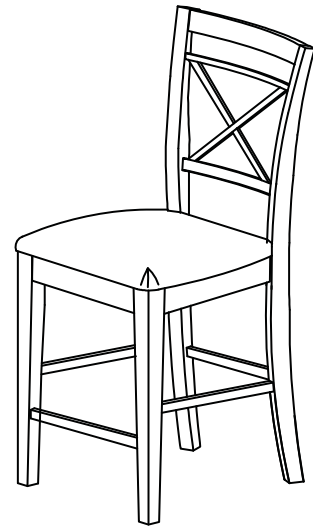

PARTS

#1 1pc x4

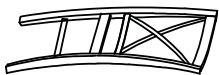

Chair Back

#2 1pc x4

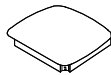

Cushion Seat

#3 2pcs x4

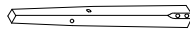

Front Leg
(L/R)

#4 1pc x4



Front stretcher

#5 2pcs x4



Side stretcher
(R/L)

HARDWARE

#A 4pcs x4



Bolt $\text{\O}1/4"$ x 3"

#B 4pcs x4

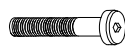

Bolt $\text{\O}1/4"$ x 2-3/8"

#C 2pcs x4

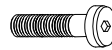

Bolt $\text{\O}1/4"$ x 1-1/2"

#D 10pcs x4



Lock Washer $\text{\O}1/4"$

#E 10pcs x4



Flat Washer $\text{\O}1/4"$

#F 1pc x4



Allen Wrench 4 mm

#G 6pcs x4

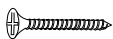

Screw $\text{\O}8$ x38mm

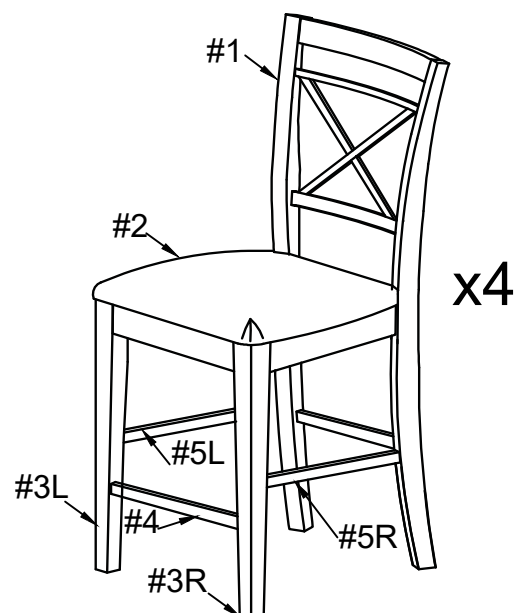

ASSEMBLY INSTRUCTIONS

1

- Part #1 x1pc
- Part #2 x1pc
- Hardware #C x2pcs
- Hardware #D x2pcs
- Hardware #E x2pcs

Align seat (#2) to the chair back (#1), then secure by using bolts (#C) with washers (#D,E).

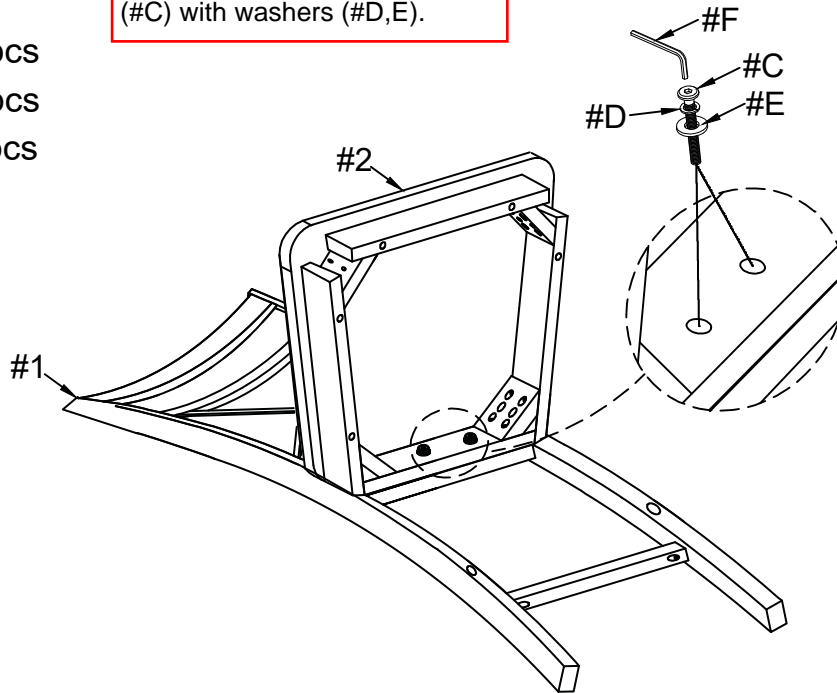

x4

2

- Hardware #A x4pcs
- Hardware #D x4pcs
- Hardware #E x4pcs

Secure seat (#2) to chair back (#1) by using bolts (#A) with washers (#D,E).

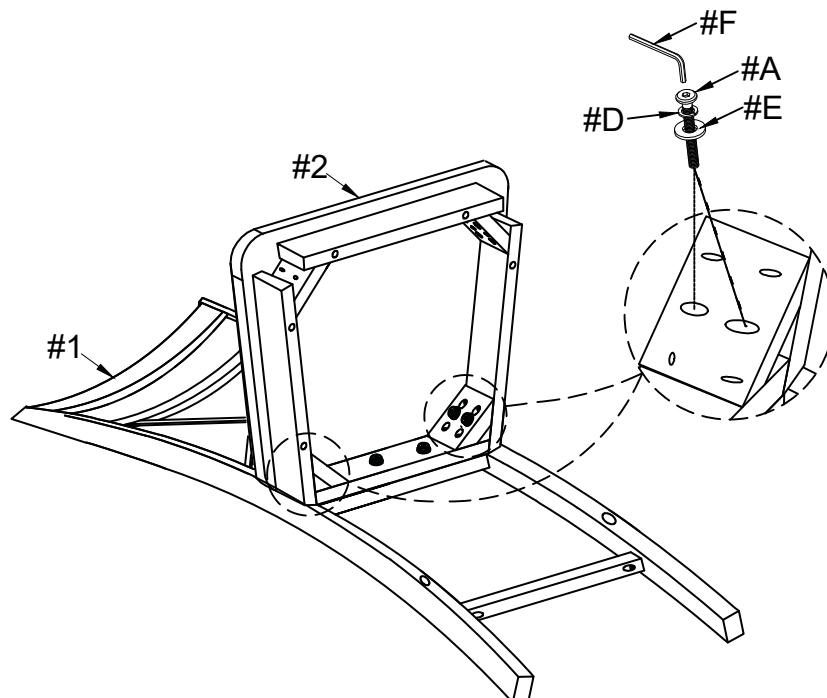

x4

ASSEMBLY INSTRUCTIONS

3

Part #3 x2pcs

Part #4 x1pc

Part #5 x2pcs

Hardware #B x4pcs

Hardware #D x4pcs

Hardware #E x4pcs

Align front legs (#3R/L) with stretchers (#4,5L/R) to the chair, then secure by using bolts (#B) with washers (#D,E).

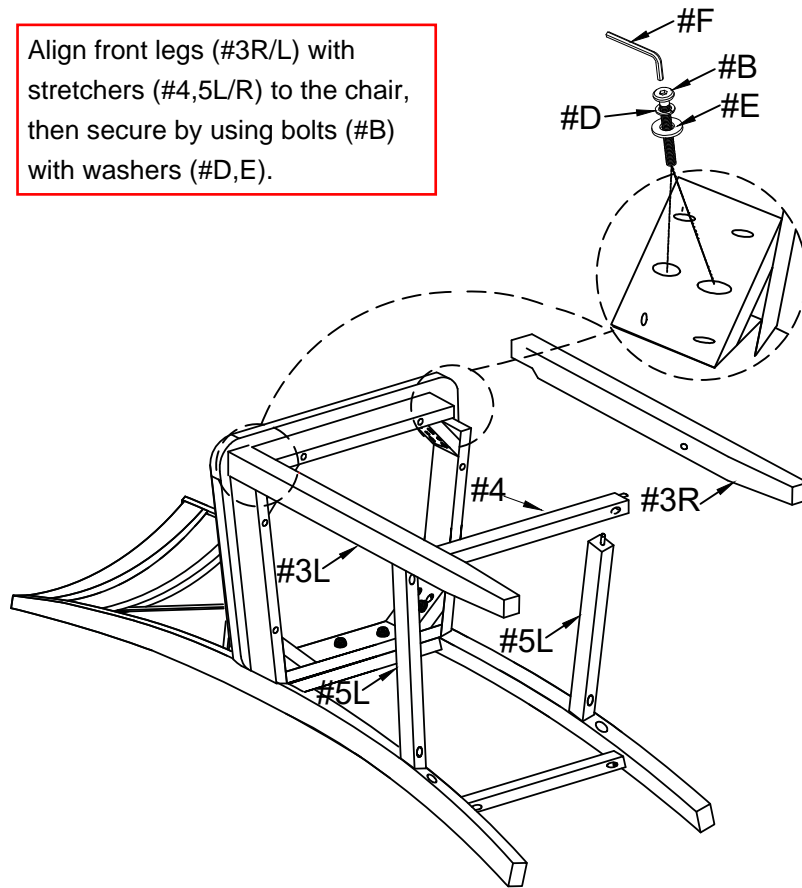

x4

4

Hardware #G x6pcs

Secure stretchers on chair by using screws (#G).

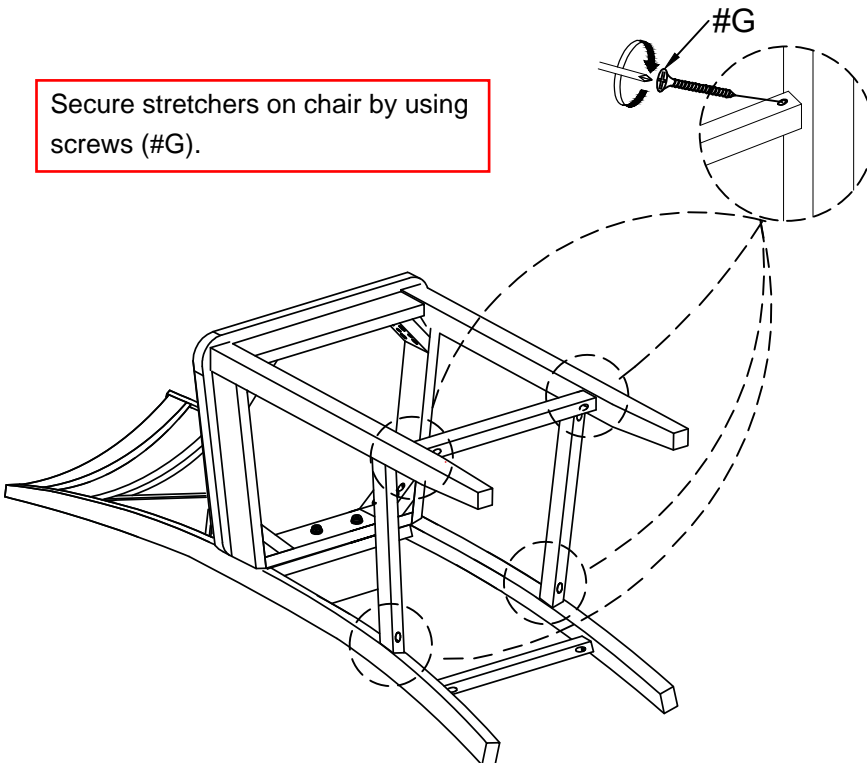

x4

ASSEMBLY COMPLETED



Please ensure the furniture rests on even and flat surface. If the product wobbles or feels loose, double-check all bolts and/or screws are properly tightened and secured.



Keep this handy!

Please retain this instruction manual and any order-related information for future reference



Lift, don't drag!

To avoid damage to product please always LIFT the product when transporting or adjusting the placement