

# Assembly Instructions

**CAUTION: You must read this Assembly Instructions before you proceed.**

**Please look in the Seat Panel for hardware packs.**

## 3 SEATER

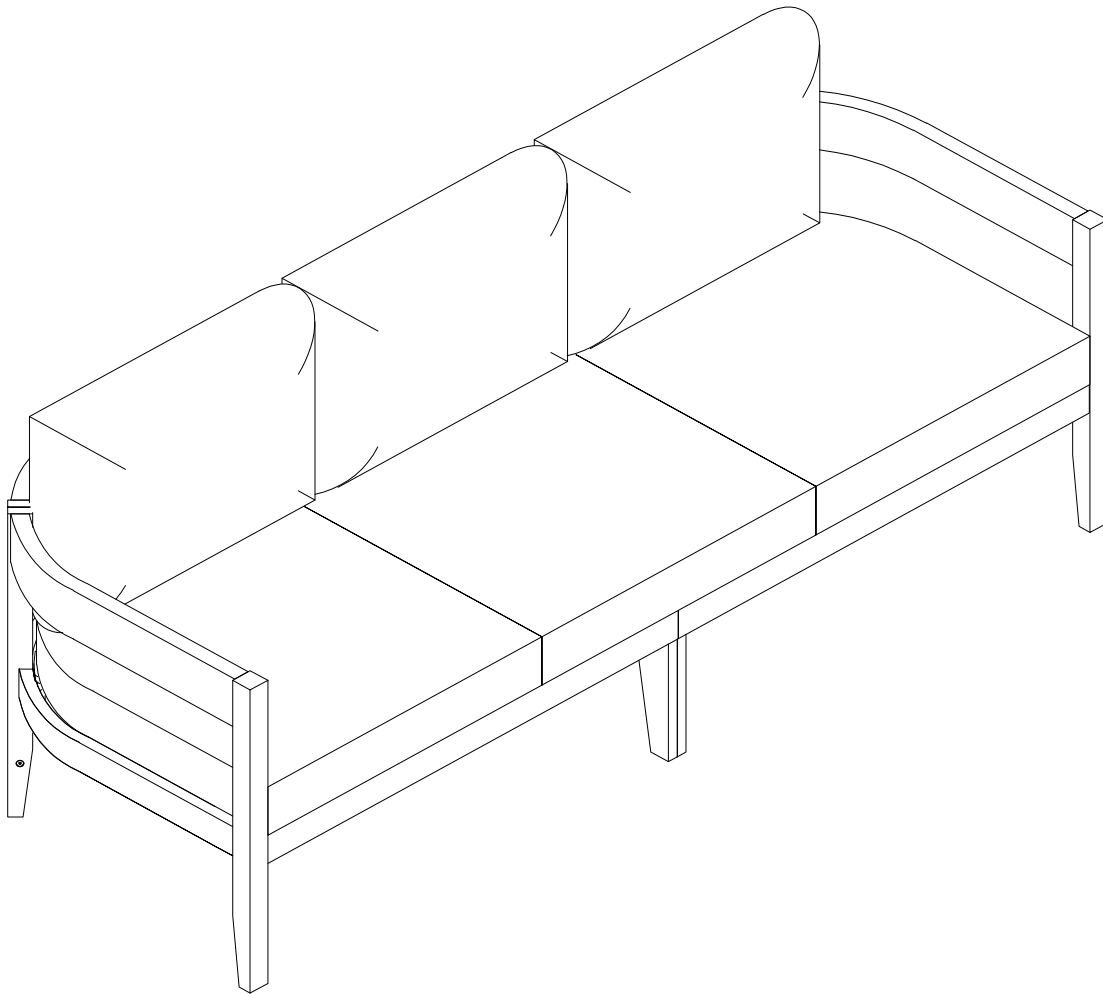

**CAUTION: This 3 Seater is NOT a TOY.**

Keep your child / children at bay during the assembly process.

Whenever lifting or moving the 3 Seater and to prevent any damage to it, two adults may be needed to execute these actions.

## Part List

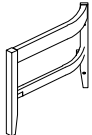
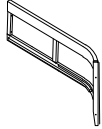
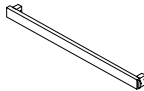
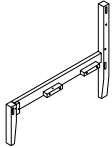
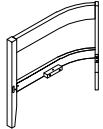
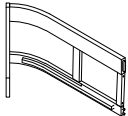
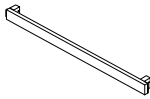
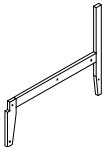
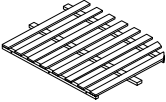
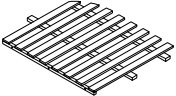
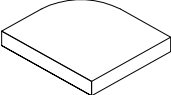
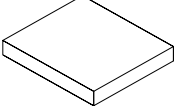
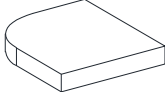
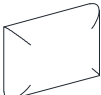
Label	Picture	Description	QTY
A		Right Leg Panel	1
B		Right Backrest Panel	1
C		Right Support Bar	1
D		Right Middle Leg panel	1
E		Left Leg Panel	1
F		Left Backrest Panel	1
G		Left Support Bar	1
H		Left Middle Leg Panel	1
I		Right Seat Panel	1
J		Left Seat Panel	1
K		Right Seat Cushion	1
L		Middle Seat Cushion	1
M		Left Seat Cushion	1
N		Back Cushion	3

# Hardware

Label	Picture	Description	QTY
①		Bolt (M6x30mm)	8
②		Sleeve Nut (M6x15mm)	11
③		Bolt (M6x45mm)	9
④		Screws (M6x60mm)	5
⑤		Bolt (M6x100mm)	3
⑥		Screws (M6x35mm)	9
⑦		Allen Wrench	2

## Assembly Preparation

Before Beginning Assembly:

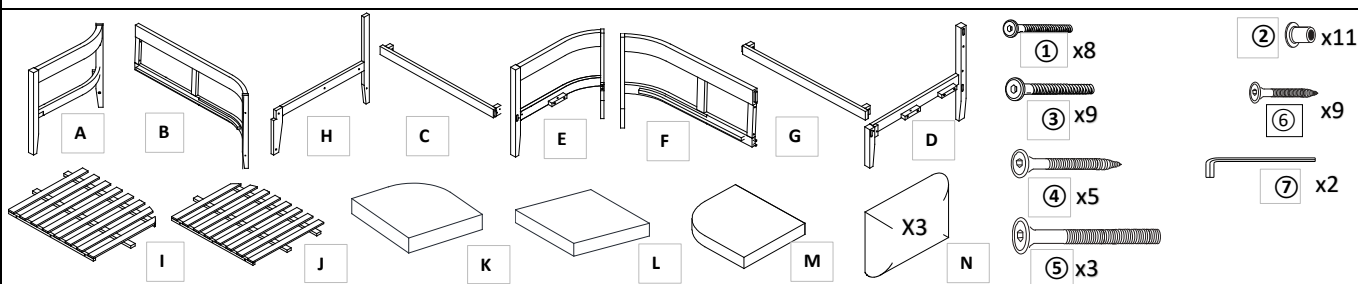

- Read instructions, cover to cover-
- Have 2 adults on hand for assembly-
- Do not assemble on flooring or carpet-
- Assemble on a clean non-marring surface (packing foam)-
- Save all packaging until finished-

## Assembly Steps

### Overview

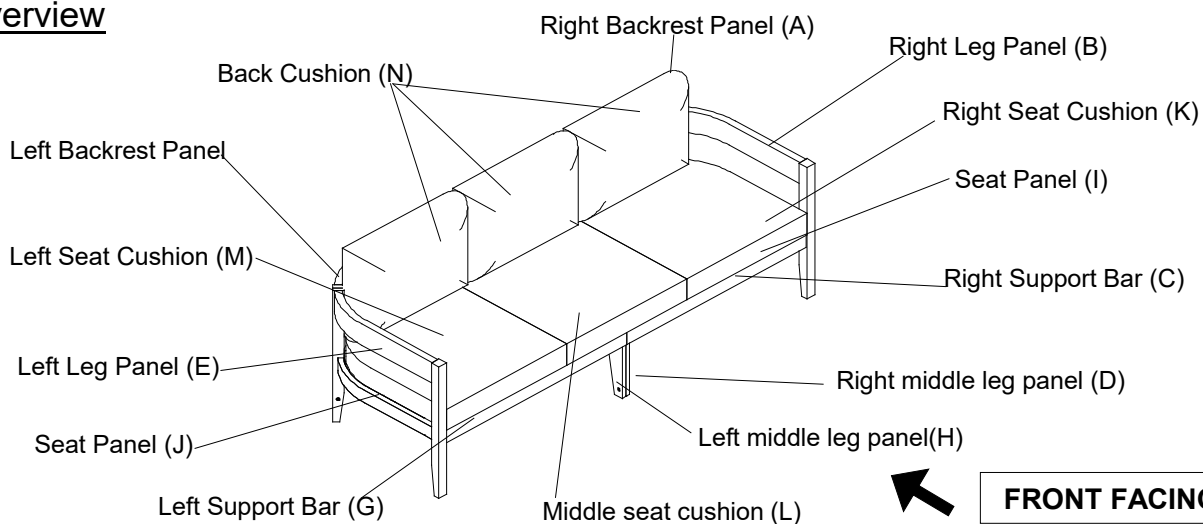

This 3 Seater has multiple parts and may require up to 60 minutes to assemble. To give you an overview of the 3 Seater parts, the above picture is provided to help you put the various parts into perspective. Please read through the instructions below to familiarise yourself with the parts and steps before assembly.

### Step 1

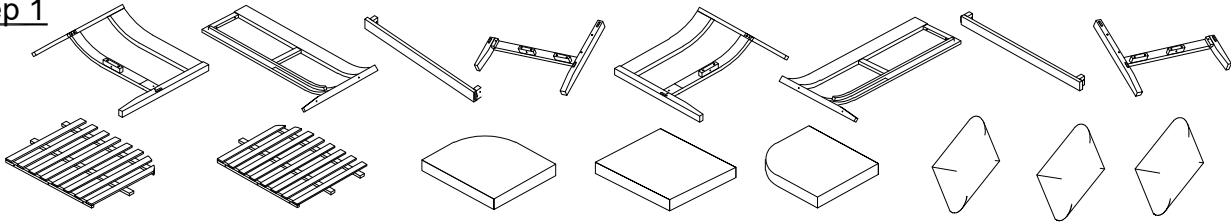

Unpack and place all parts on a clean, non-marring surface.

### Step 2

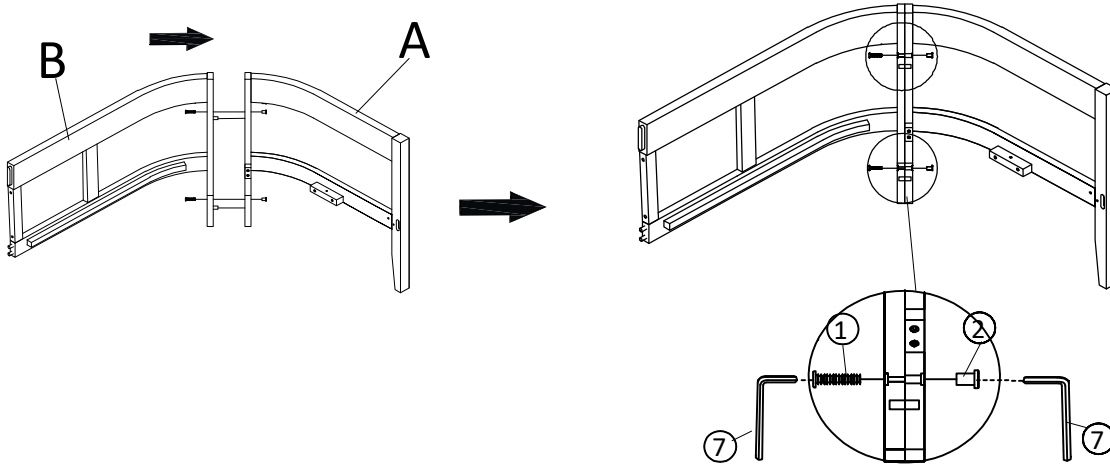

Place the Right Leg Panel (B) upright as shown in the picture above onto a clean, soft surface to avoid any scratches or damage to the product.

With assistance from your adult partner(s), attach the Right Backrest Panel (B) to the Right leg Panel (A), using 2 (two) Bolts (1) and 2 (two) Sleeve Nuts (2) and the Allen Wrench (7). Turn the Bolts (1) into the Sleeve Nuts (2) as shown above.

**DO NOT fully tighten the Bolts at this time.**

### Step 3

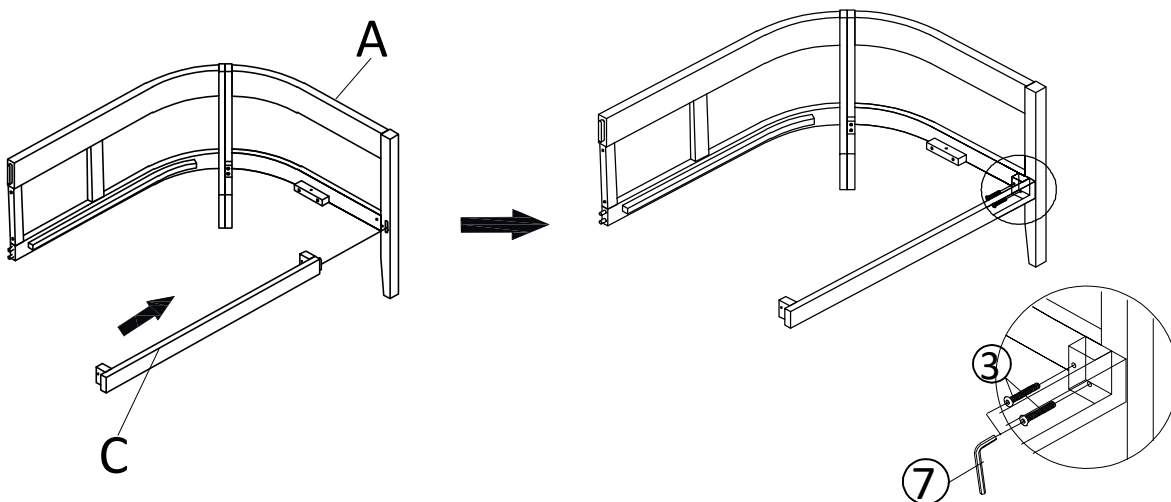

With assistance from your adult partner(s), attach the Support Bar (C) to the assembled parts in Step 2 by using Bolts (3) and the Allen Wrench (7) as shown above.

**DO NOT fully tighten the Bolts at this time.**

### Step 4

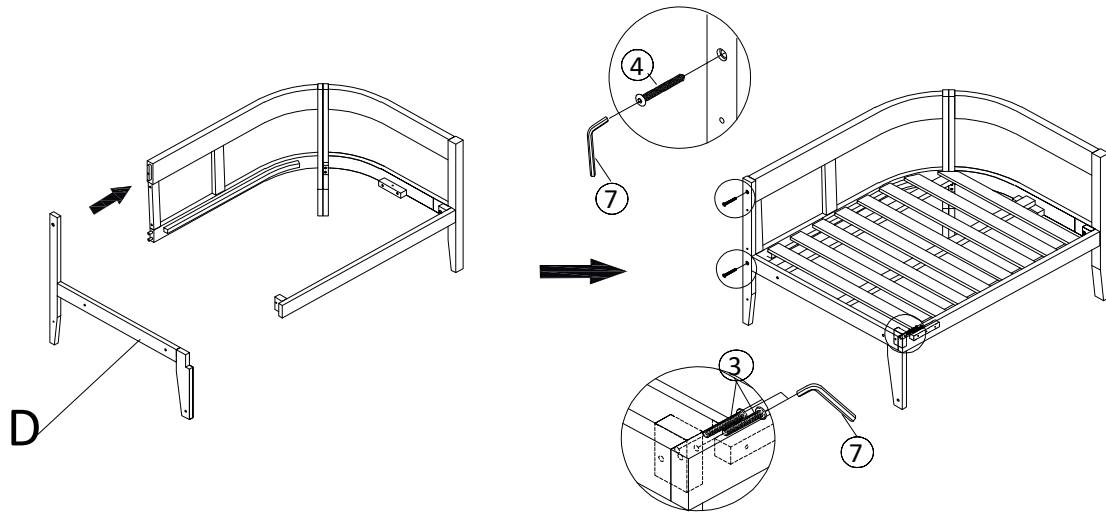

With assistance from your adult partner(s), attach the Right Middle Leg Panel (D) to the assembled parts in Step 3 by using Bolts (③), Screws (④) and the Allen Wrench (⑦) as shown above.  
**DO NOT fully tighten the Bolts, Screws at this time.**

### Step 5

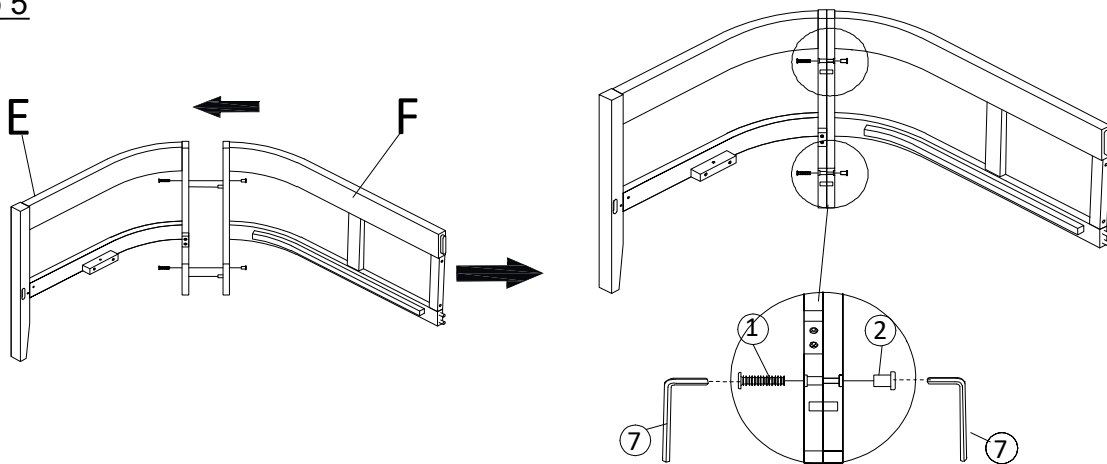

Place the Left Leg Panel (E) upright as shown in the picture above onto a clean, soft surface to avoid any scratches or damage to the product.

With assistance from your adult partner(s), attach the Left Backrest Panel (F) to the Left Leg Panel (E), using 2 (two) Bolts (①) and 2 (two) Sleeve Nuts (②) and the Allen Wrench (⑦). Turn the Bolts (①) into the Sleeve Nuts (②) as shown above.

**DO NOT fully tighten the Bolts at this time.**

### Step 6

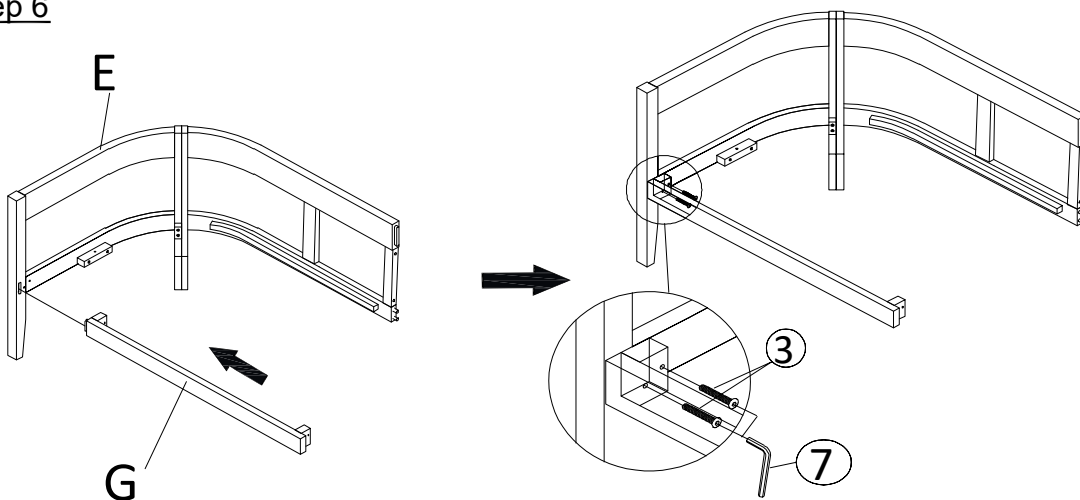

With assistance from your adult partner(s), attach the Support Bar (G) to the assembled parts in Step 5 by using Bolts (③) and the Allen Wrench (⑦) as shown above.

**DO NOT fully tighten the Bolts at this time.**

### Step 7

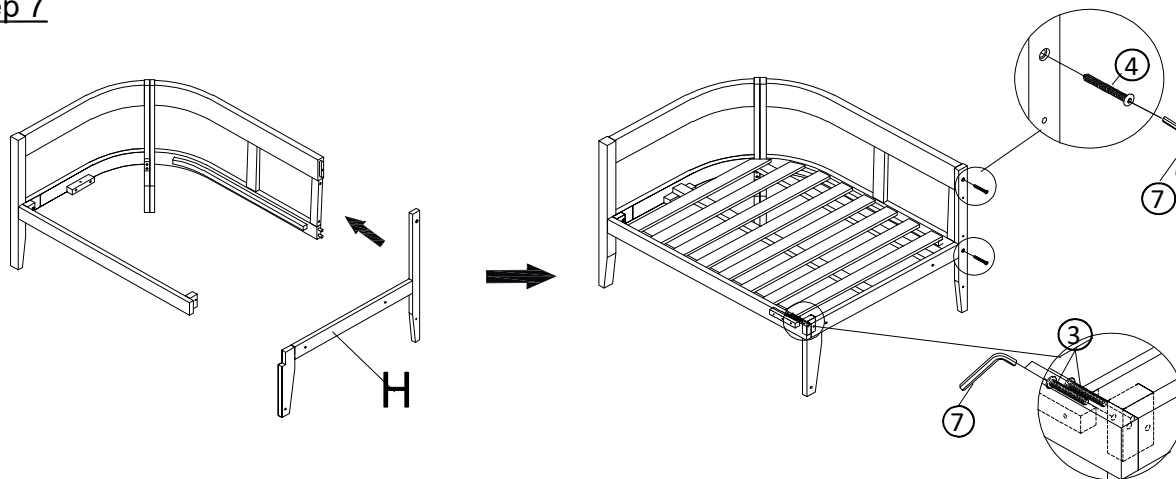

With assistance from your adult partner(s), attach the Left middle leg panel (H) to the assembled parts in Step 6 by using Bolts (3), Screws (4) and the Allen Wrench (7) as shown above.  
**DO NOT fully tighten the Bolts, screws at this time.**

### Step 8

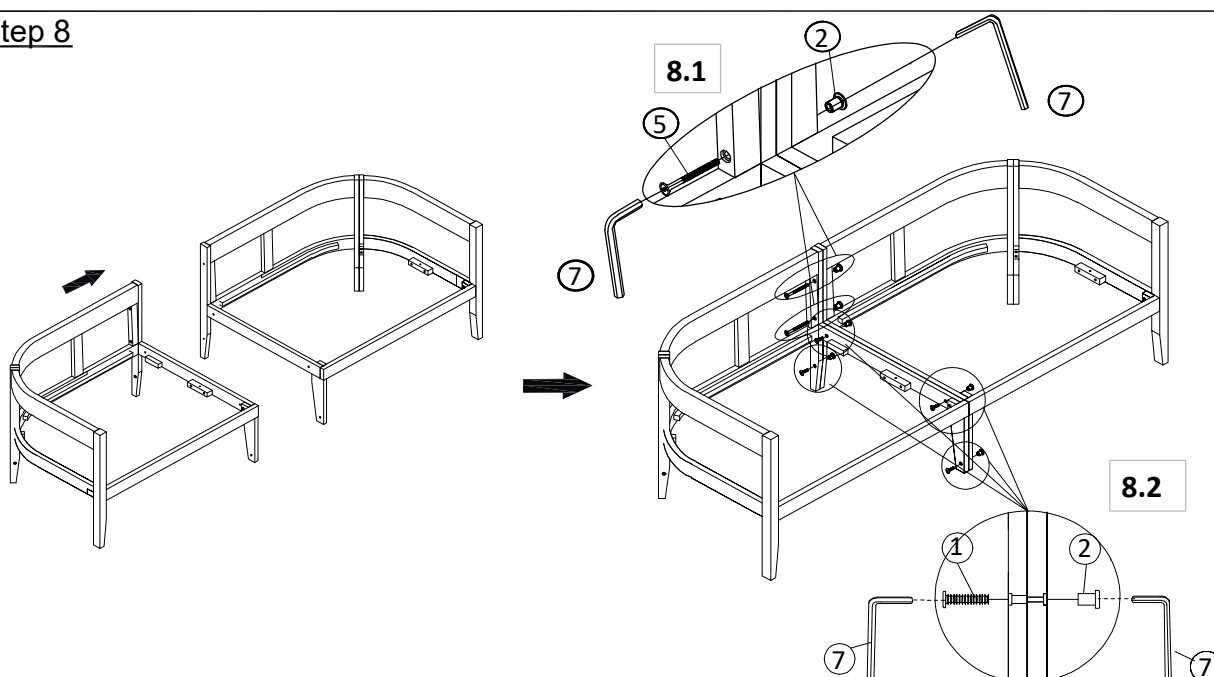

With assistance from your adult partner(s), attach the assembled parts in step 7 to the assembled parts in step 4  
Step 8.1: use 2 (two) Bolts (5) and 2 (two) Sleeve Nuts (2) and the Allen Wrench (7), turn the Bolts (5) into the Sleeve Nuts (2) as shown above.  
Step 8.2: use 2 (two) Bolts (1) and 2 (two) Sleeve Nuts (2) and the Allen Wrench (7), turn the Bolts (1) into the Sleeve Nuts (2) as shown above.  
**DO NOT fully tighten the Bolts at this time.**

### Step 9

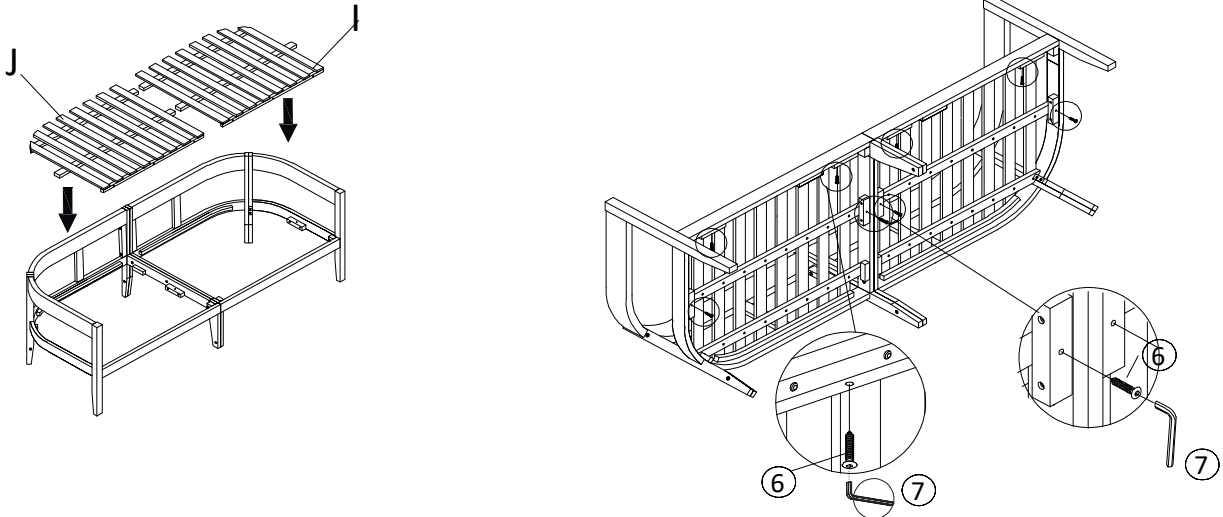

With assistance from your adult partner(s), attach the Right Seat Panel (I) and the Left Seat Panel (J) to the assembled parts in step 8 using Screws (6) and the Allen Wrench (7) as shown above.

**DO NOT fully tighten the Screws at this time.**

### Step 10

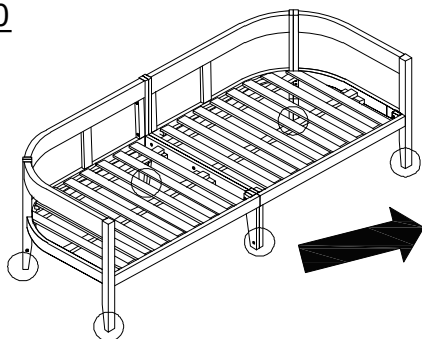

Adjust high for balance    Adjust low for balance

Adjust Pre-installed Levelers height for balance

Turn the 3 Seater right side up.

Inspect the 3 Seater and make sure all parts are adequately connected.

In a sequential manner, tighten all Screws and Bolts at all joints.

With assistance from your adult partner, adjust the Levelers to the desired height to avoid wobbles.

**CAUTION: When tightening these screws and bolts, tighten sequentially.**

**DO NOT tighten any screw or bolt fully and then move towards the next one. This could cause the frame to warp.**

**WARNING!! IF THE 3 Seater IS NOT STABLE, IT COULD LEAD TO DAMAGING THE PRODUCT.**

### Step 11

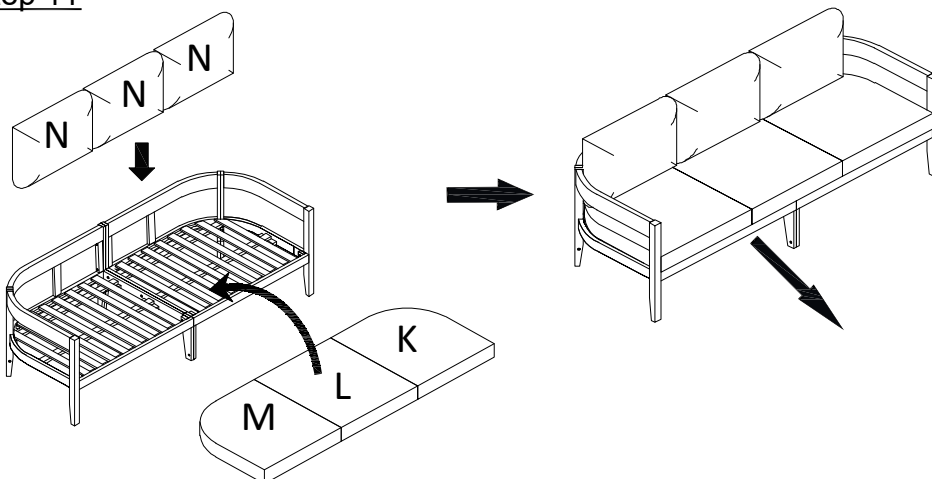



















Place the Right Seat Cushion (K), Middle seat cushion (L), Left Seat Cushion (M) and the Back Cushions (N) onto the 3 Seater.

Then affix the "magic tape straps" around the 3 Seater as shown above.

Your 3 Seater is ready to be used.

**This 3 Seater can only be used on a flat, level surface.**

## Care & Maintenance

-   ● Do not put hot items directly on furniture surface
  -   ● Do not clean furniture with harsh cleansers or polish.
  -   ● To obtain the longest lifespan of your outdoor products, minimizing exposure to direct sunlight is recommended.
  -   ● Children should not climb or jump on the furniture.
  -   ● Do not write on furniture without a padded barrier to protect the surface.
  -   ● To obtain the longest lifespan of your outdoor products, avoid extended and lengthy exposure to rain, snow, and direct sunshine. Whenever possible cover the product and /or place under patio or awnings.
  -   ● Not for commercial use. For residential use only .
  -   ● Stains may be removed with mild soap solution and damp cloth.
- 
-   ● Dust and pick-up spills using a clean, non-colored, lint-free cloth .