

ASSEMBLY INSTRUCTIONS

End Table

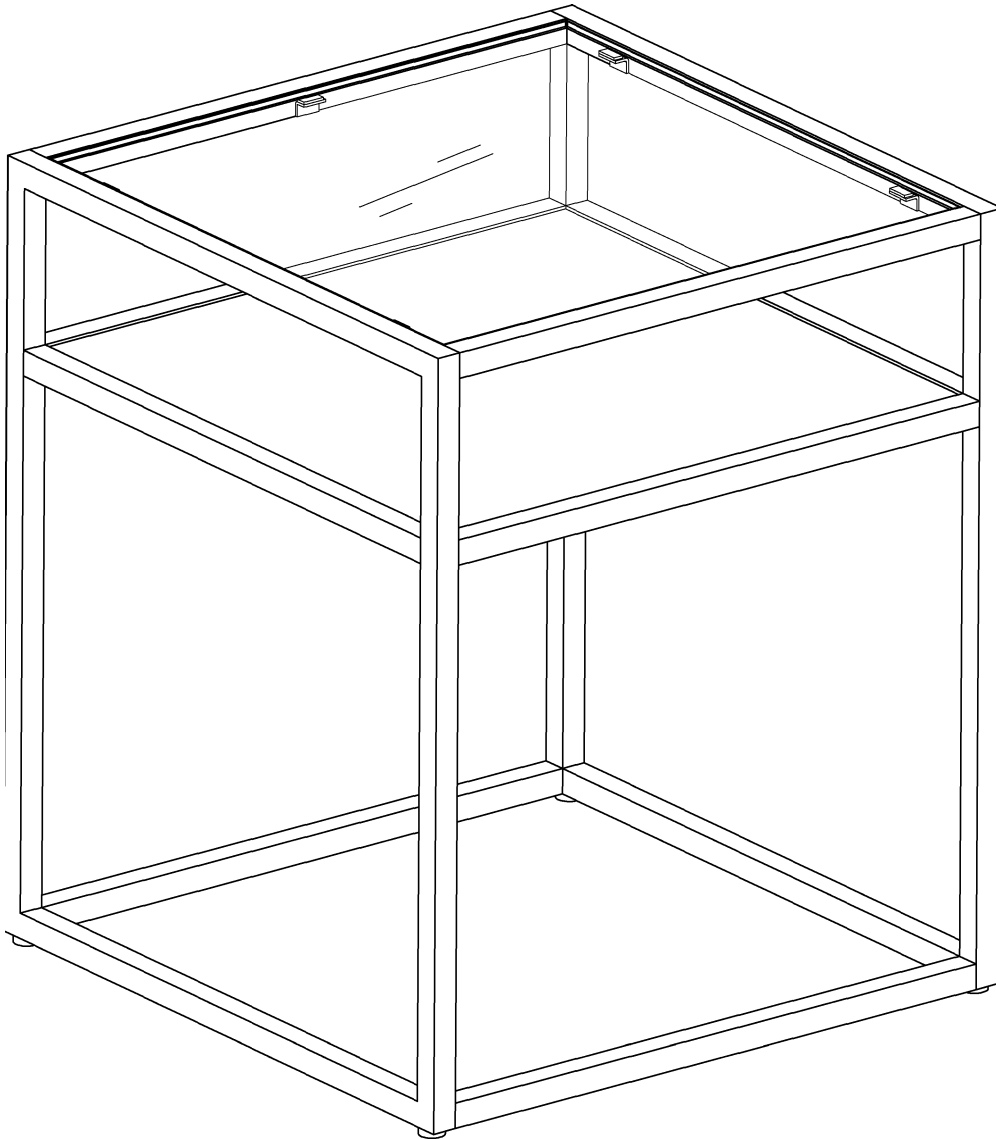

Thank you for purchasing this product. We trust that you will be completely satisfied with your product for many years to come. Bush Furniture products are backed by a 1-year warranty and crafted with today's styles in mind for the way you work.

Merci d'avoir acheté ce produit. Nous sommes sûr que vous serez complètement satisfait de votre meuble pendant de nombreuses années. Les produits Bush Furniture sont garantis pendant 1 an et sont conçus dans les styles actuels tout en gardant à l'esprit votre façon de travailler.

Gracias por comprar este producto de Confiamos que usted estará completamente satisfecho con su mueble por muchos años. Los productos de Bush Furniture tienen 1 año de garantía y son diseñados con los estilos de hoy en mente para la manera que usted vive.

IT'S AS EASY AS 1,2,3

Assembly tips:

1. Read the instructions and become familiar with the parts.
2. Ensure this carton contains all parts, fasteners and hardware.
3. To protect floors, assemble the furniture on the carton.
4. An assistant may be helpful.
5. Use of power tools is not recommended.

Conseils d'assemblage:

1. Lisez les instructions et familiarisez-vous avec les pièces.
2. Assurez-vous que le carton contient toutes les pièces, toutes les pièces de fixation et toute la quincaillerie.
3. Pour protéger vos sols, assemblez le meuble sur le carton.
4. Il peut être utile de vous faire aider.
5. L'utilisation d'outils électriques n'est pas recommandée.

Consejos de Ensamblaje:

1. Lea las instrucciones y familiarícese con las partes.
2. Asegúrese de que esta caja contenga todas las piezas, los sujetadores y el equipo.
3. Para proteger el piso, ensamble el mueble en el carton.
4. Un asistente puede serle útil.
5. El uso de herramientas eléctricas no se recomienda.

IMPORTANT SAFETY INFORMATION



WARNING

Units must be assembled with the instructions, parts and hardware provided. Improper assembly or use could cause structural failure, instability, tip over, and/or serious injury.

Las unidades deben ser ensambladas de acuerdo a las instrucciones y usando el herraje incluido. El ensamblado incorrecto puede causar un fallo estructural, inestabilidad, o que la unidad se derrumbe, causando posibles heridas personales.

Les unités doivent être assemblées avec les instructions et les matériels donnés. Si vous ne le construisez pas correctement ceci pourrait causer des dommages structuraux, instabilité, se renverser et blesser quelqu'un.



WARNING

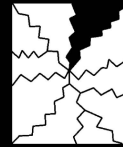

Risk of breaking glass. Handle glass carefully during assembly. Use eye and hand protection. Improper handling can result in cuts or lacerations.

Riesgo de romper el vidrio. Maneje el vidrio con cuidado al ensamblar esta unidad. Use protección para sus ojos y sus manos. El manejo inapropiado del vidrio puede causarle cortaduras o laceraciones.

Risque de bris de verre. Faites attention lors de la manipulation du verre pendant l'assemblage. Utilisez des protections pour les yeux et les mains. Une mauvaise manipulation peut provoquer des coupures ou des lacérations.

MAXIMUM RECOMMENDED WEIGHT LOADS

MAXIMUM WEIGHT: 25 LBS (11.3 KG)
PESO MÁXIMO: 25 LIBRAS (11.3 KILOGRAMO)
POIDS MAXIMUM: 25 LIVRES (11.3 KILOGRAMME)

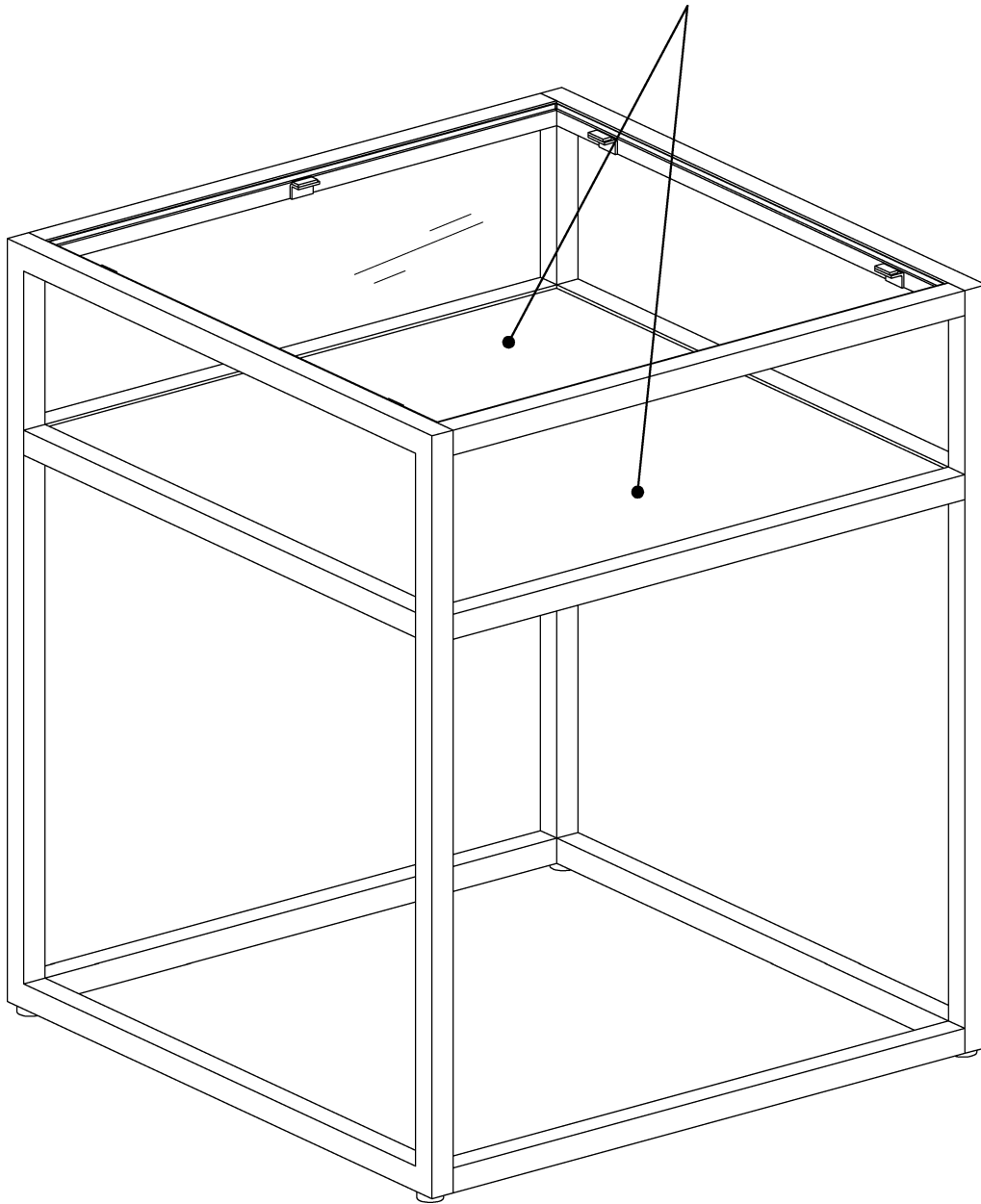

ATT120RB

A	[1]	G188326	D	[2]	H188329
B	[1]	S188327	E	[2]	H188330
C	[2]	H188328	F	[2]	H188331

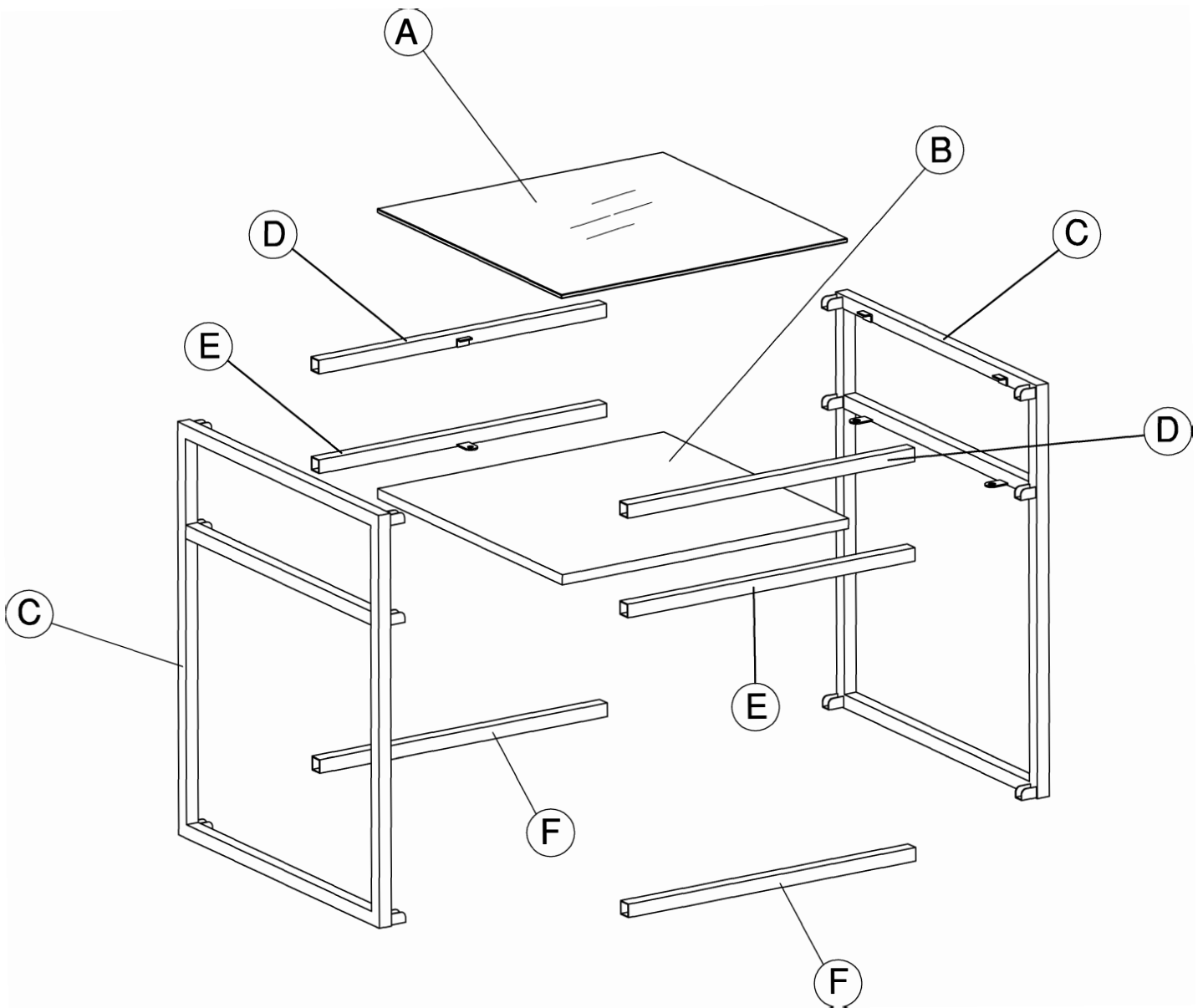
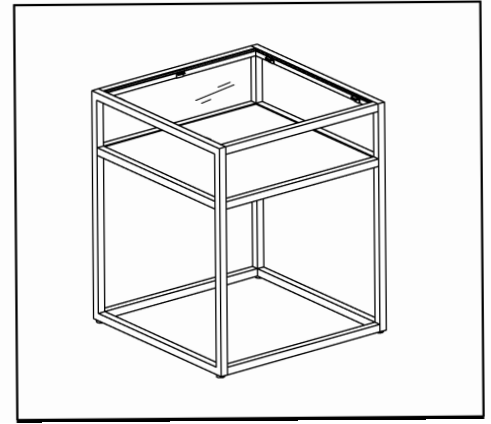

FASTENERS / HARDWARE

Fasteners are shown in actual size.

Los fijadores son demostrados en su tamaño actual.

Les attaches sont montrées dans l'échelle grandeur.

H182884

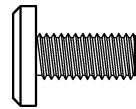

[18]

M6 x 13mm

H189285

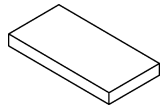

[6]

Glass Cushion

H189286

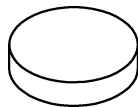

[4]

Bumper Pad

H182971



[1]

Hexagon Wrench 4mm

STEP 1

H182884

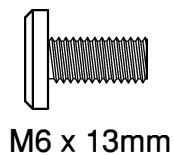

[2]

H182971



[1]

Hexagon Wrench 4mm

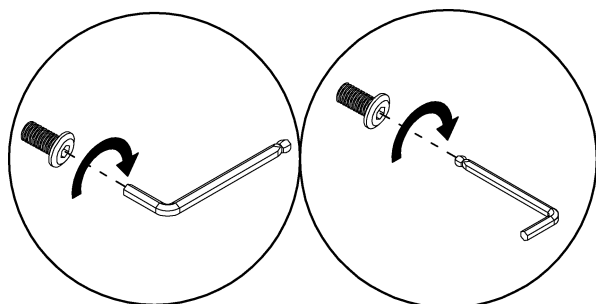
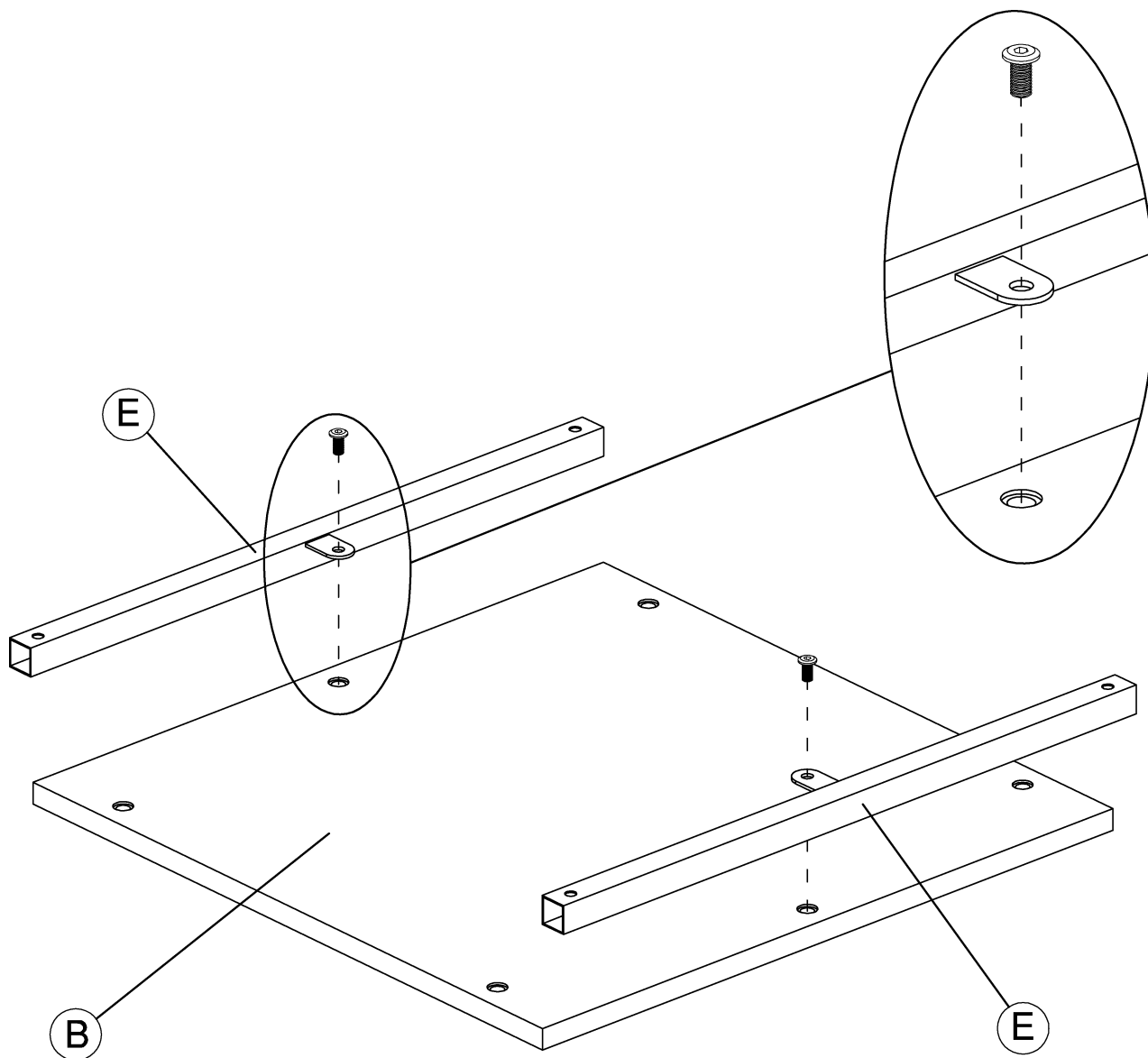

Do not fully tighten.
No apriete completamente.
Ne pas viser a fond.

STEP 2

H182884

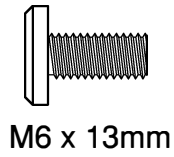

[4]

H182971



[1]

Hexagon Wrench 4mm

Do not fully tighten.
No apriete completamente.
Ne pas viser a fond.

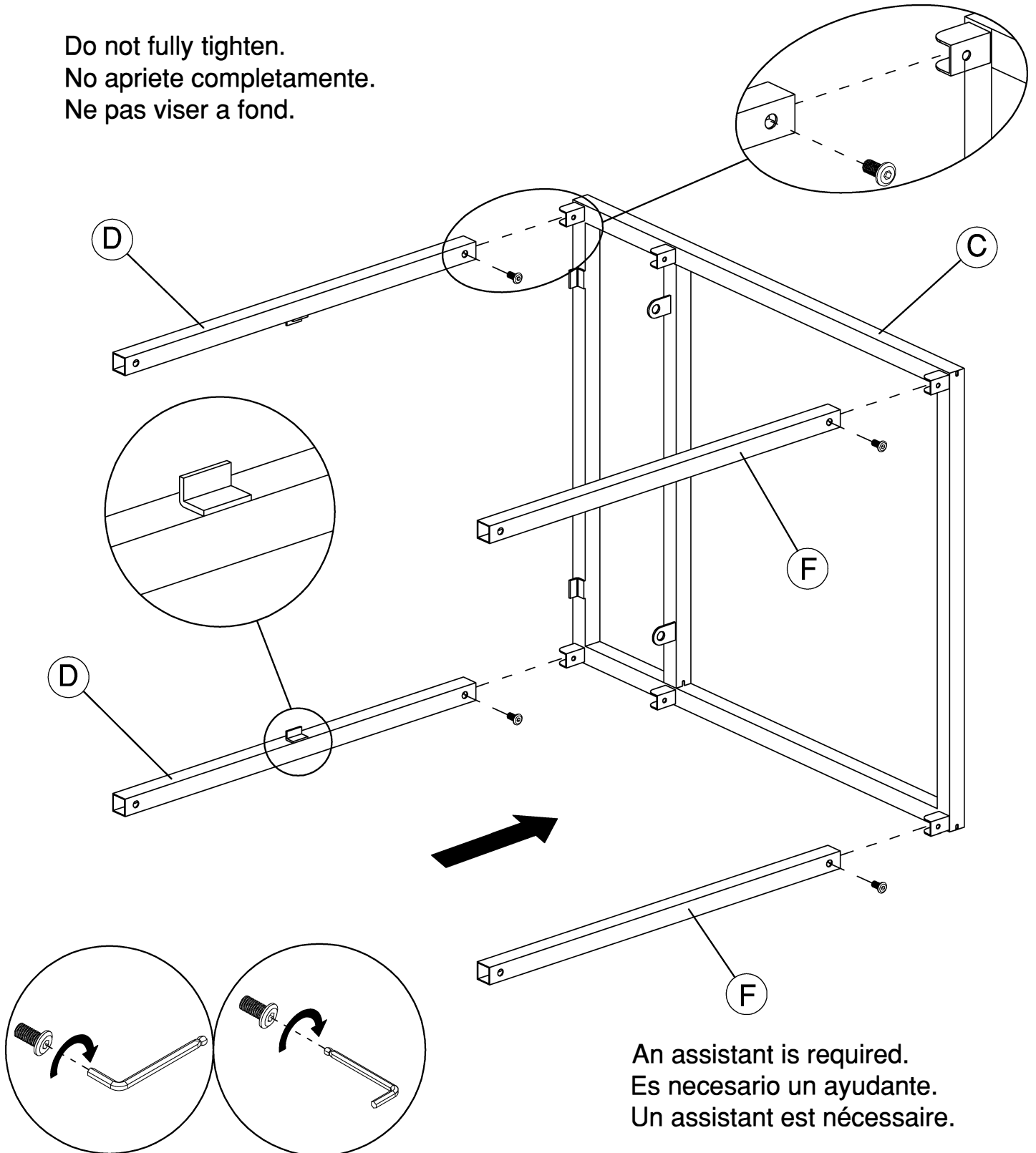

STEP 3

H182884

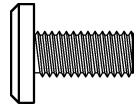

M6 x 13mm

[4]

H182971



Hexagon Wrench 4mm

[1]

Do not fully tighten.
No apriete completamente.
Ne pas visser a fond.

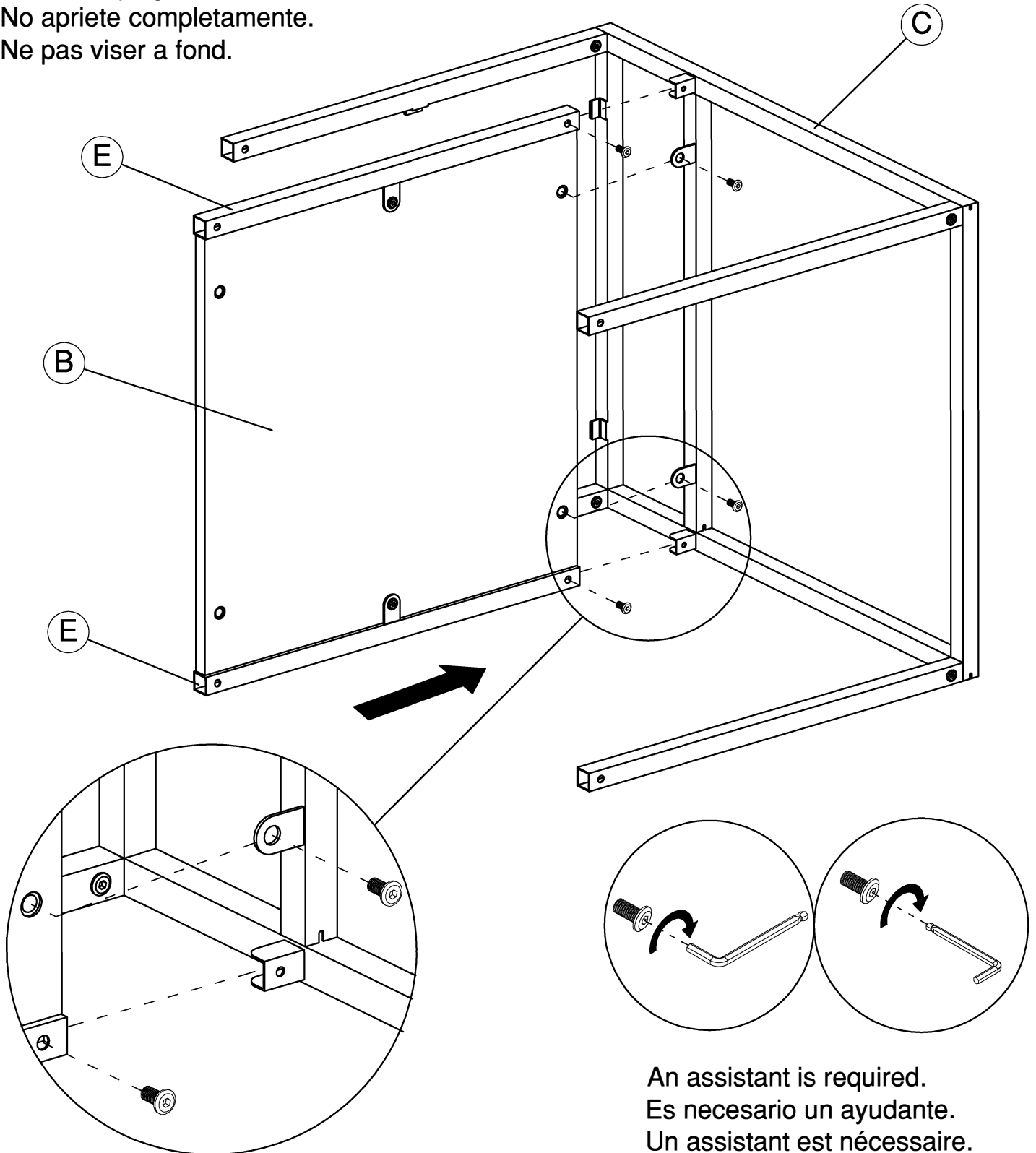

An assistant is required.
Es necesario un ayudante.
Un assistant est nécessaire.

STEP 4

H182884

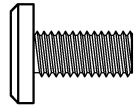

[8]

M6 x 13mm

H182971



[1]

Hexagon Wrench 4mm

Tighten all screws.
Apriete todos los tornillos.
Serrez toutes les vis.

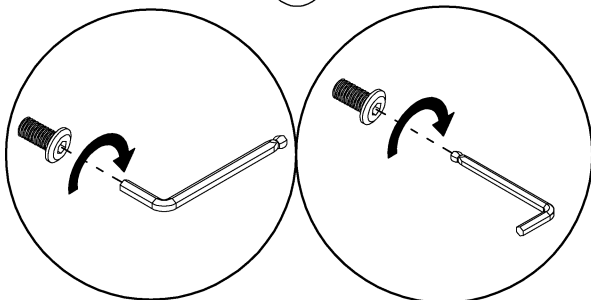
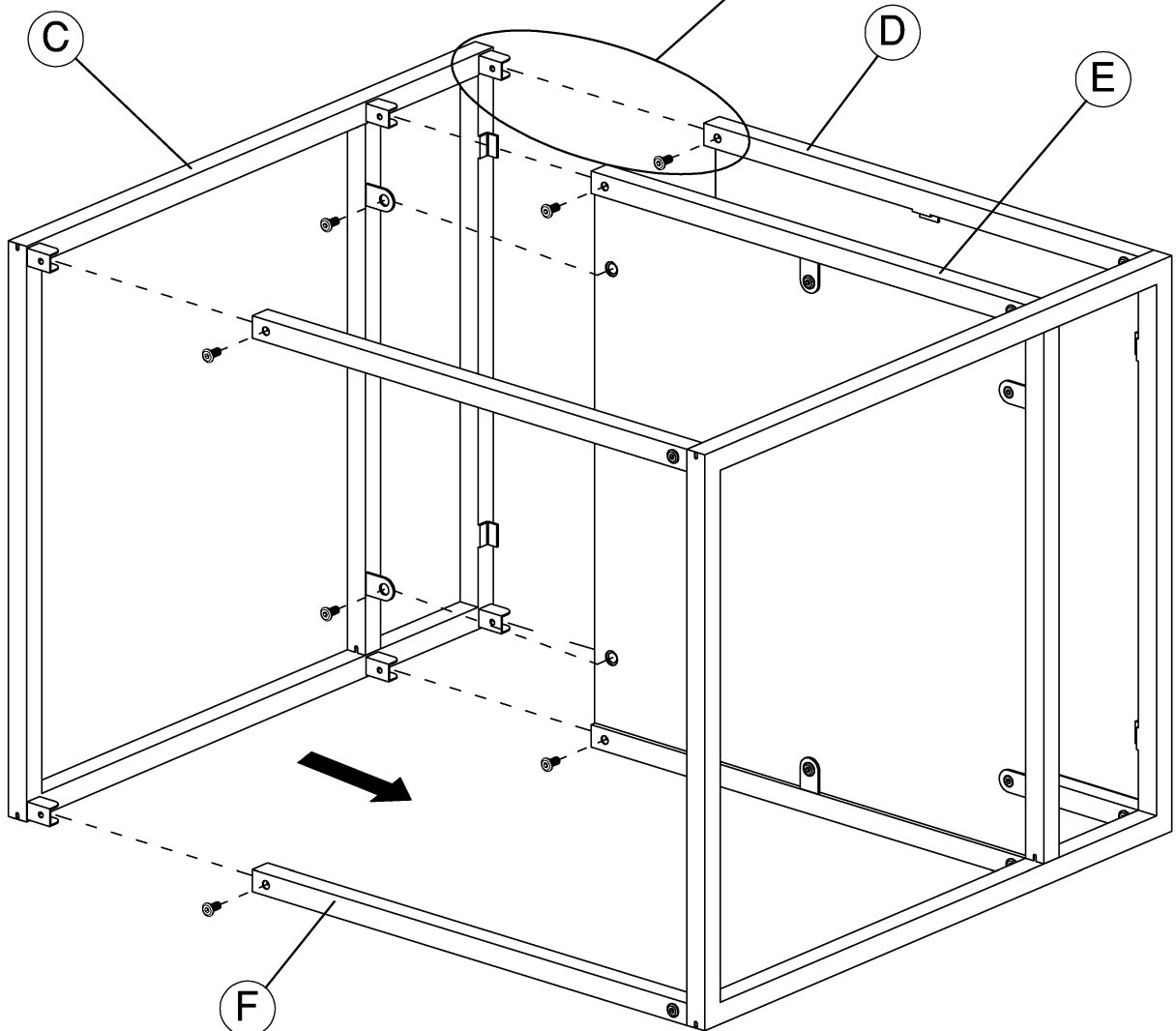
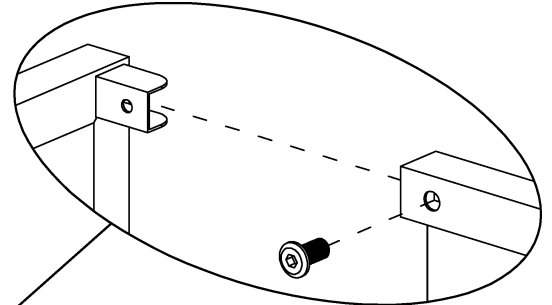

An assistant is required.
Es necesario un ayudante.
Un assistant est nécessaire.

STEP 5

H189286

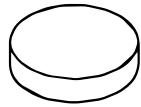

[4]

Bumper Pad

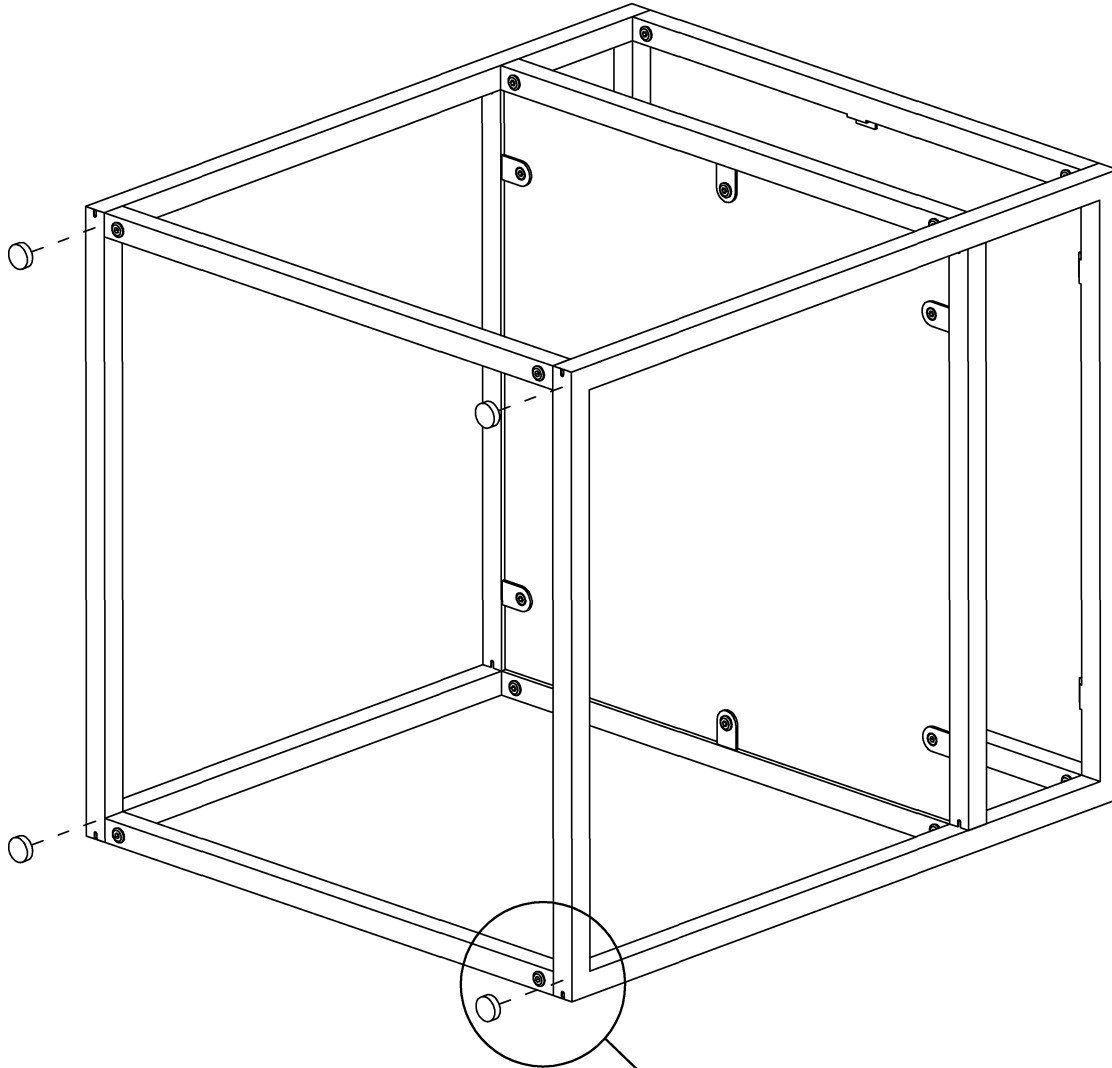

1

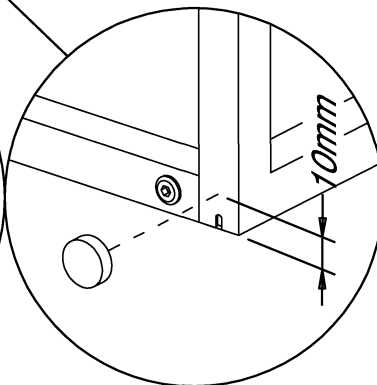

2

STEP 6

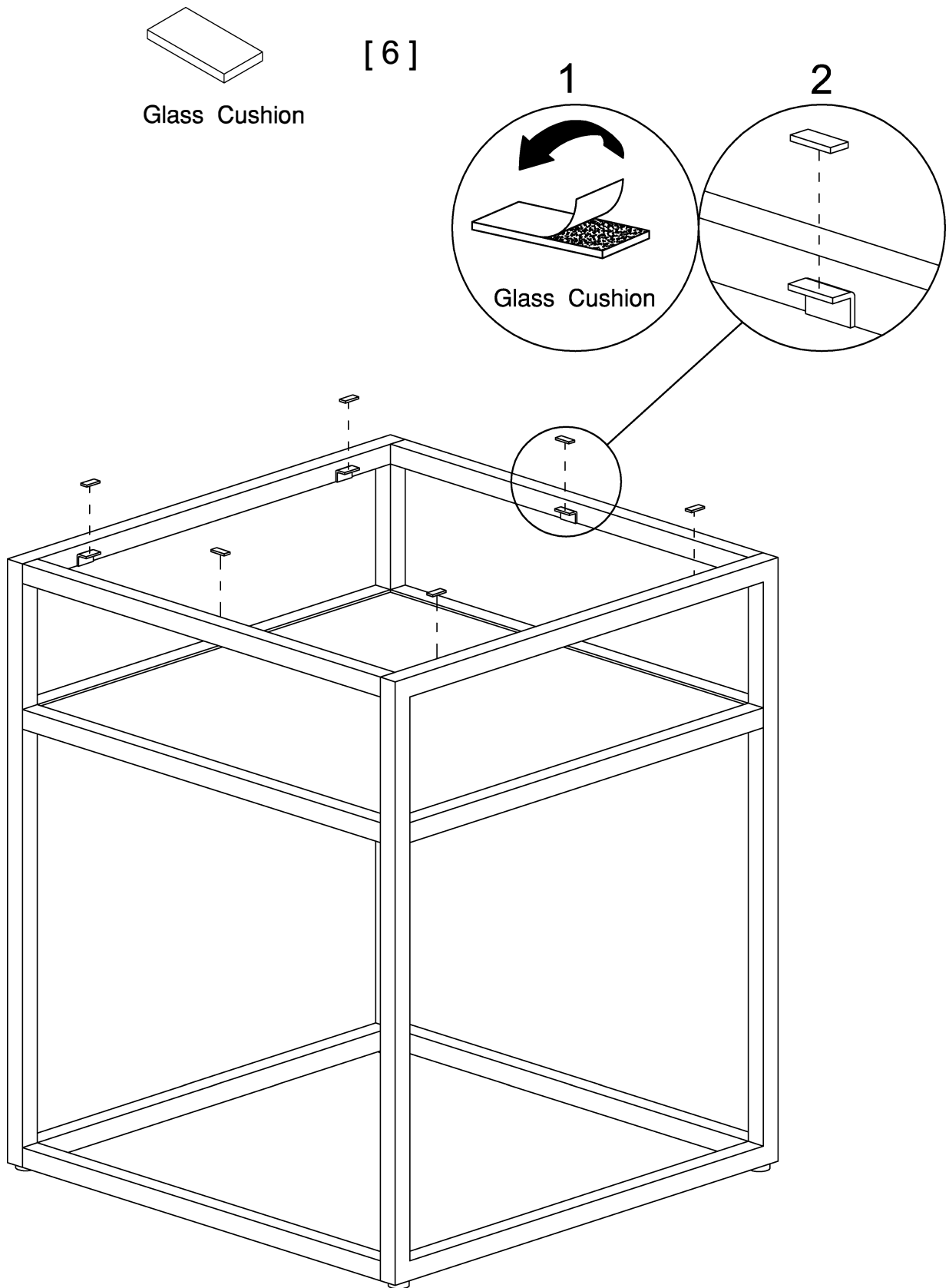

With assistant carefully stand unit up.

Con un asistente cuidadosamente levante la unided a una posicion vertical.

Avec l'aidé d'un assistant placez soigneusement l'unité debout.

STEP 7

An assistant is required.
Es necesario un ayudante.
Un assistant est nécessaire.

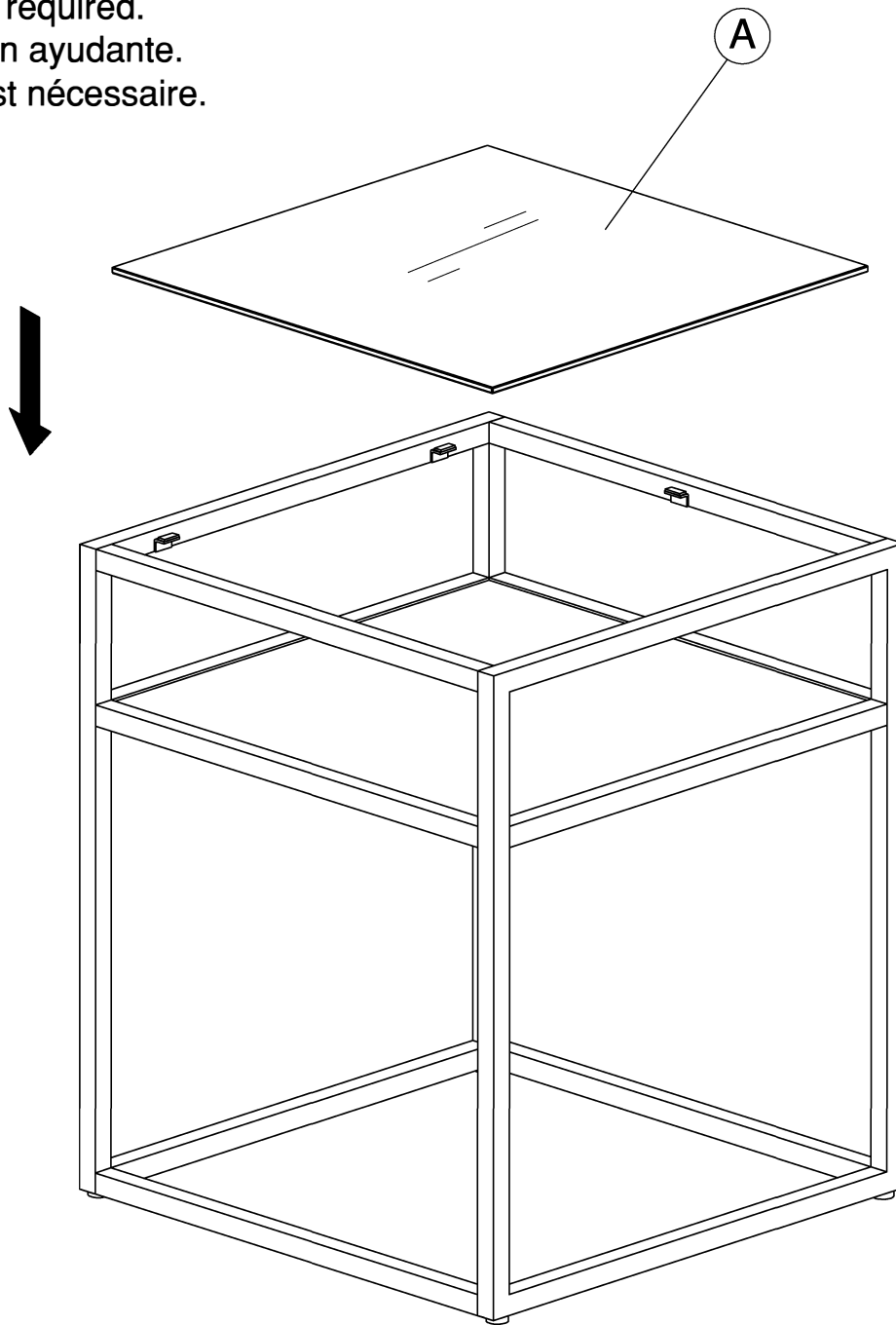

CAUTION



**RISK OF BREAKING GLASS.
HANDLE GLASS CAREFULLY
DURING ASSEMBLY. USE EYE
AND HAND PROTECTION.
IMPROPER HANDLING CAN
RESULT IN CUTS OR
LACERATIONS.**

**RIESGO DE ROMPER EL VIDRIO.
MANEJE EL VIDRIO CON
CUIDADO AL ENSAMBLAR ESTA
UNIDAD. USE PROTECCIÓN
PARA SUS OJOS Y SUS MANOS.
EL MANEJO INAPROPIADO DEL
VIDRIO PUEDE CAUSARLE
CORTADURAS O
LACERACIONES.**

**RISQUE DE BRIS DE VERRE. FAITES
ATTENTION LORS DE LA
MANIPULATION DU VERRE PENDANT
L'ASSEMBLAGE. UTILISEZ DES
PROTECTIONS POUR LES YEUX ET
LES MAINS. UNE MAUVAISE
MANIPULATION PEUT PROVOQUER
DES COUPURES OU DES
LACÉRATIONS.**