









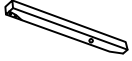

# ASSEMBLY INSTRUCTION

# INSTRUCCIONES

## PARTS LIST

## LISTA DE PARTES

1		1 PC / PIEZA
2		1 PC / PIEZA
3		2 PCS / PIEZAS R = 1, L = 1
4		2 PCS / PIEZAS R = 1, L = 1
5		1 PC / PIEZA

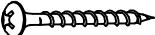
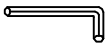
A	 $\varnothing 1/4" \times 20 \times 3"$ (chair back leg corner)	4 PCS / PIEZAS
B	 $\varnothing 1/4" \times 20 \times 2-1/2"$ (front leg)	4 PCS / PIEZAS
C	 $\varnothing 1/4" \times 20 \times 1-1/2"$ (chair back center)	1 PC / PIEZA
D	 5/16" x 12mm	9 PCS / PIEZAS
E	 5/16" x 19mm	9 PCS / PIEZAS
F	 1-1/2"	6 PCS / PIEZAS
G	 5mm	1 PC / PIEZA

## ASSEMBLY INSTRUCTION

## INSTRUCCIONES

**STEP 1**  
**PASO 1**

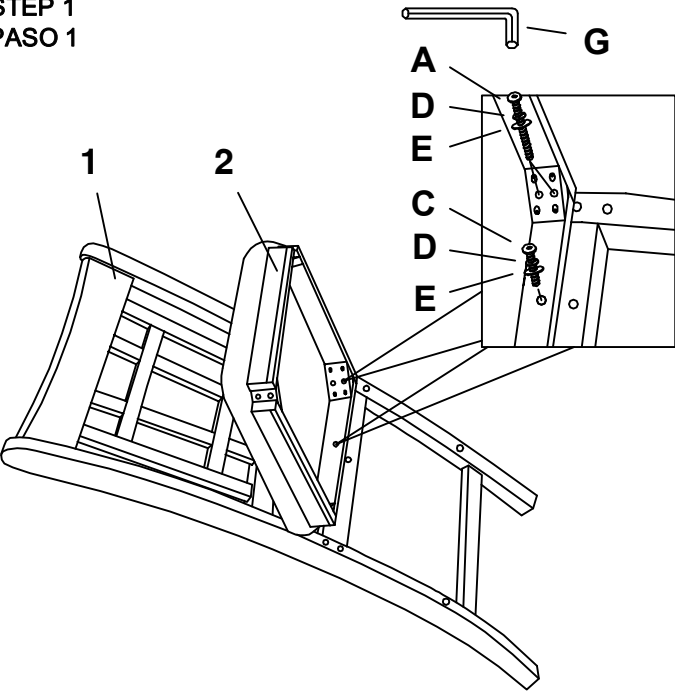

**STEP 2**  
**PASO 2**

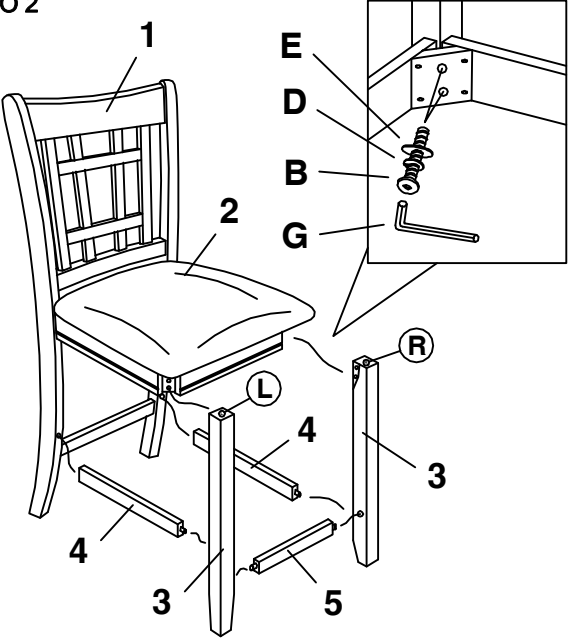

**STEP 3**  
**PASO 3**

NOT PROVIDED

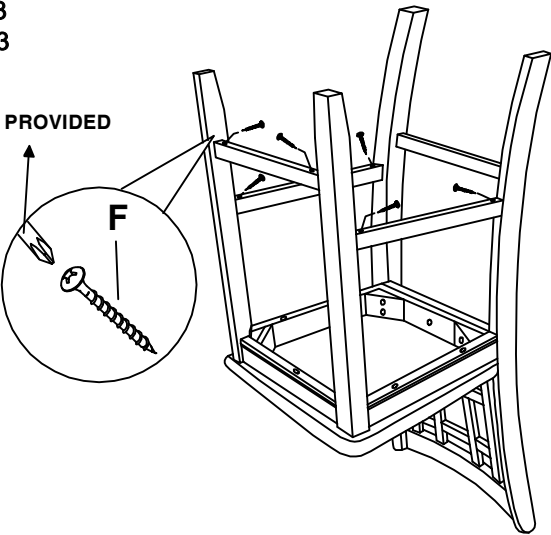



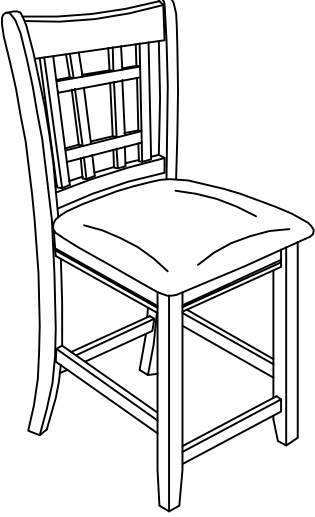

**STEP 4**  
**PASO 4**





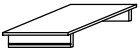

DO NOT TIGHTEN ALL BOLTS UNTIL COMPLETELY ASSEMBLED.  
NO APRETAR LOS TORNILLOS HASTA ARMAR COMPLETAMENTE.

# ASSEMBLY INSTRUCTION INSTRUCCIONES

## PARTS LIST LISTA DE PARTES

1		1 PC / PIEZA
2		1 PC / PIEZA
3		4 PCS / PIEZAS
4		4 PCS / PIEZAS
5		1 PC / PIEZA

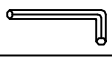
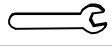
A		Ø 5/16"	4 PCS / PIEZAS
B		Ø1/4" x 20 x 1-3/16"	16 PCS / PIEZAS
C		Ø 5/16" x 12mm	20 PCS / PIEZAS
D		Ø 5/16" x 19mm	16 PCS / PIEZAS
E		Ø 5/16" x 22mm	4 PCS / PIEZAS
F		5mm	1 PC / PIEZA
G		1/2" x 3-1/2"	1 PC / PIEZA

## ASSEMBLY INSTRUCTION INSTRUCCIONES

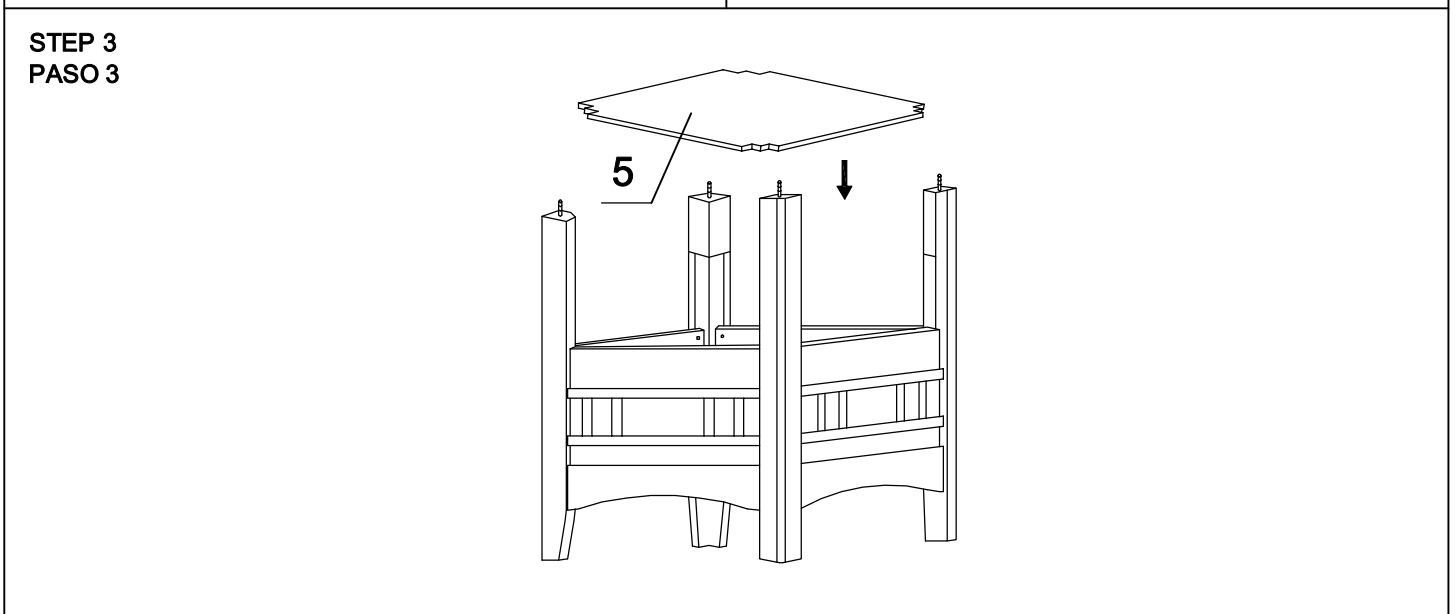
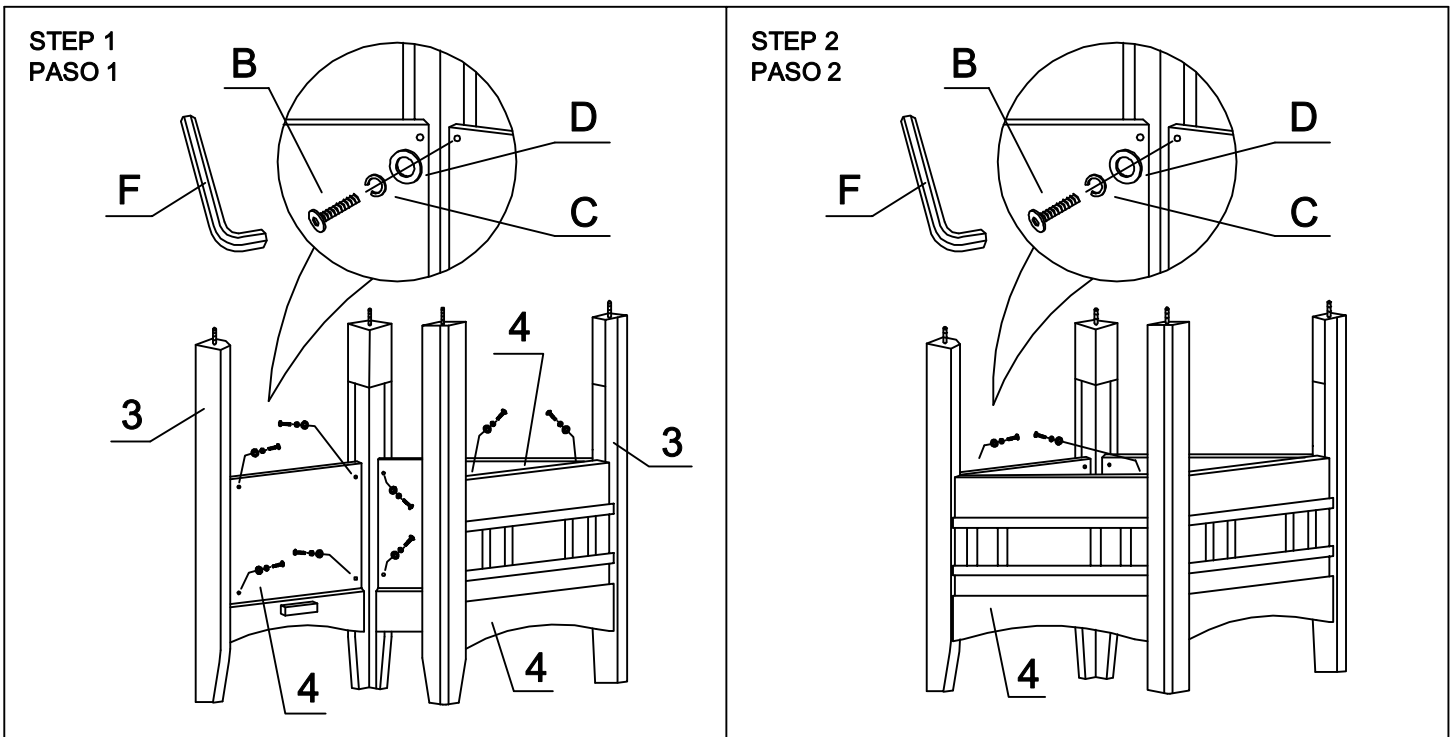

# ASSEMBLY INSTRUCTION

## INSTRUCCIONES

STEP 4  
PASO 4

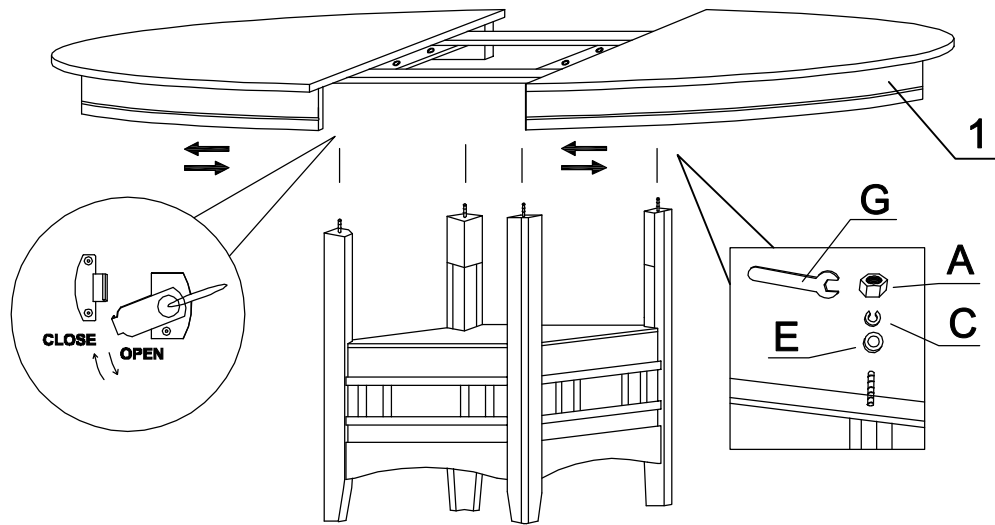

STEP 5  
PASO 5

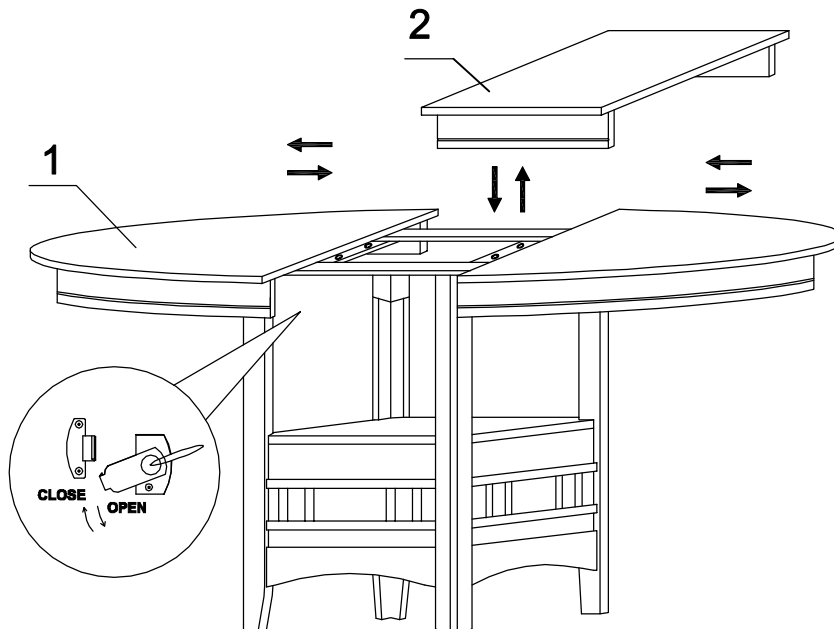

STEP 6  
PASO 6

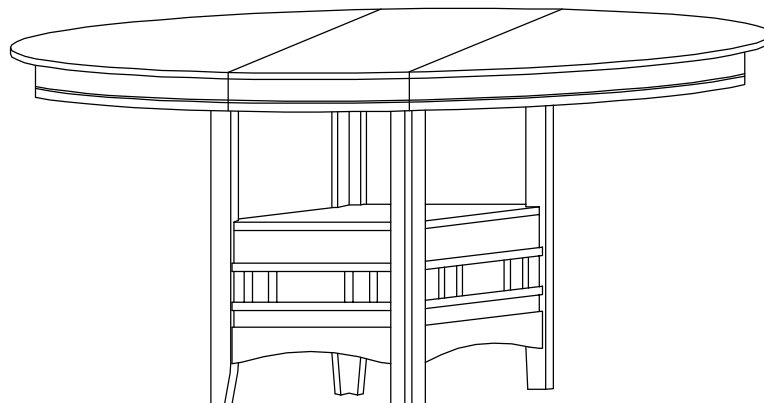

DO NOT TIGHTEN ALL BOLTS UNTIL COMPLETELY ASSEMBLED.  
NO APRETAR LOS TORNILLOS HASTA ARMAR COMPLETAMENTE.