

STEP 11

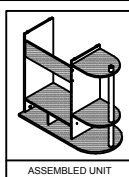

STEP 13

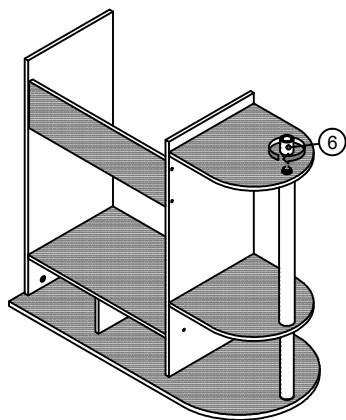
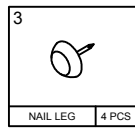
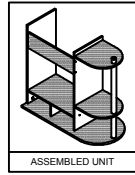
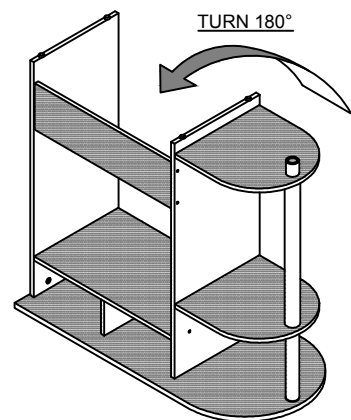

STEP 12

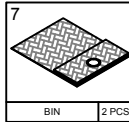
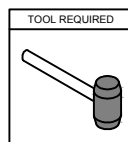
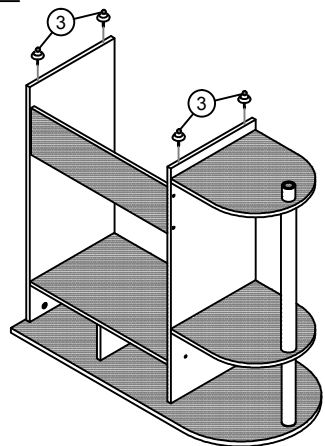

STEP 14

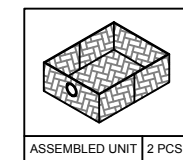
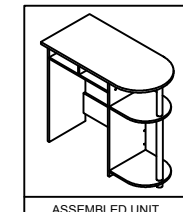
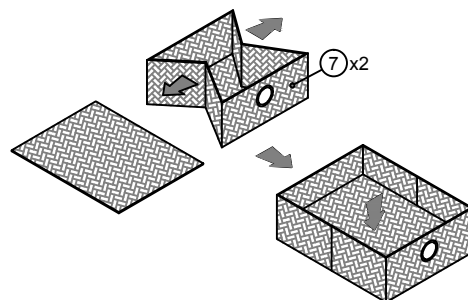

STEP 15

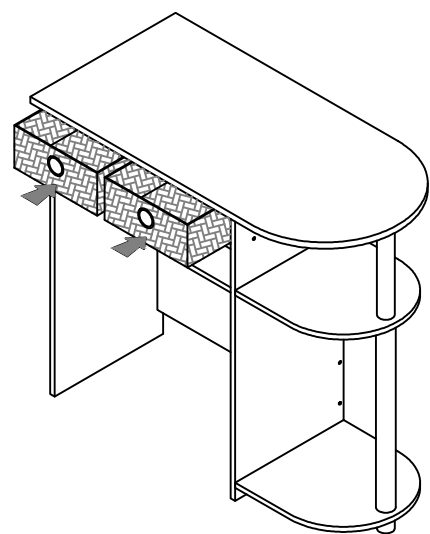

Recommended Maximum Weight

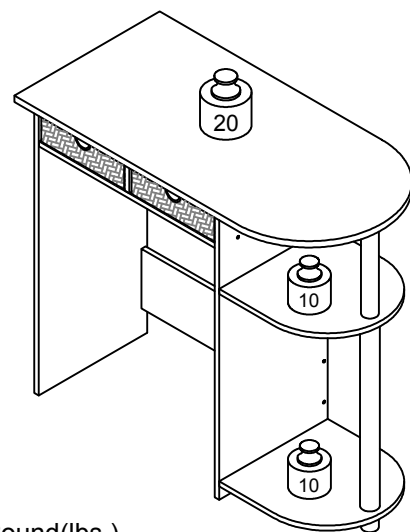

*Unit in Pound(lbs.)

WARNING:

>This unit has been designed to support the maximum loads shown. Exceeding these load limits could cause sagging, instability, product collapse, and/or serious injury.

>DO NOT allow children to climb on unit.

> Put heavier items on lower shelves.

Assembly Instruction

Go Green Home Laptop Notebook Computer Desk / Table

00:30

Approx. 30 minutes



Recomm. 1 Person

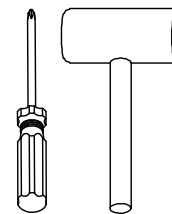

Tool Required

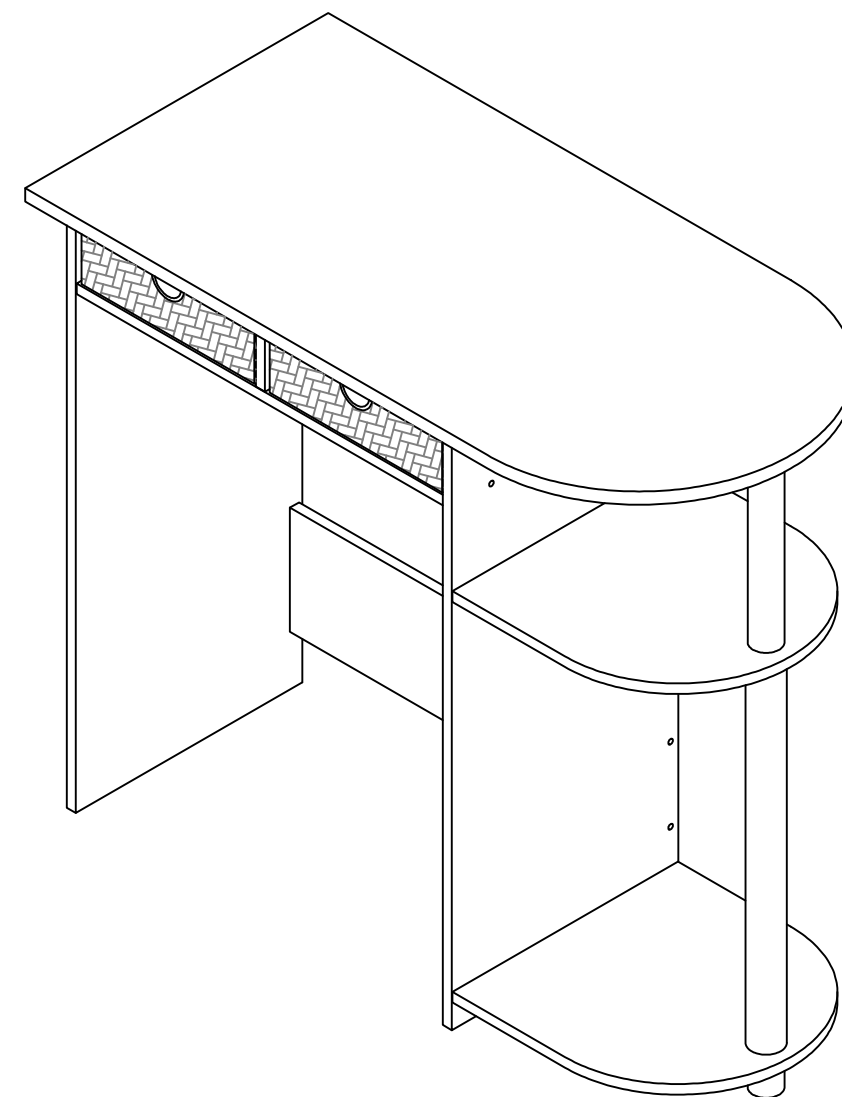

EXPLODED VIEW

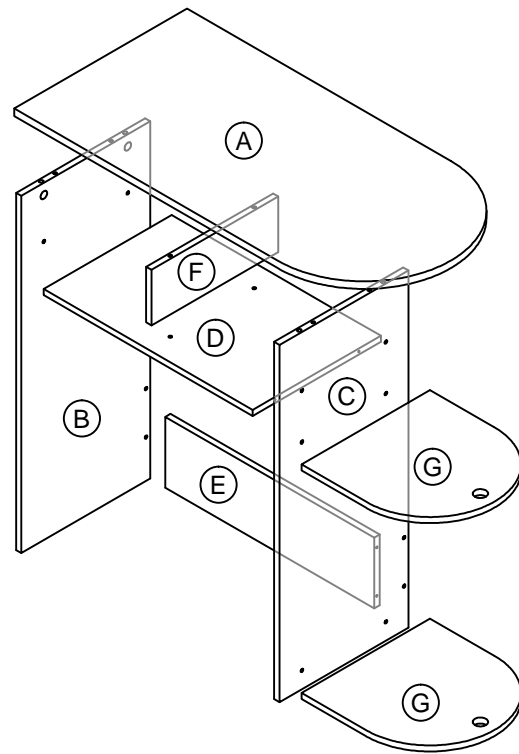

PARTS LIST

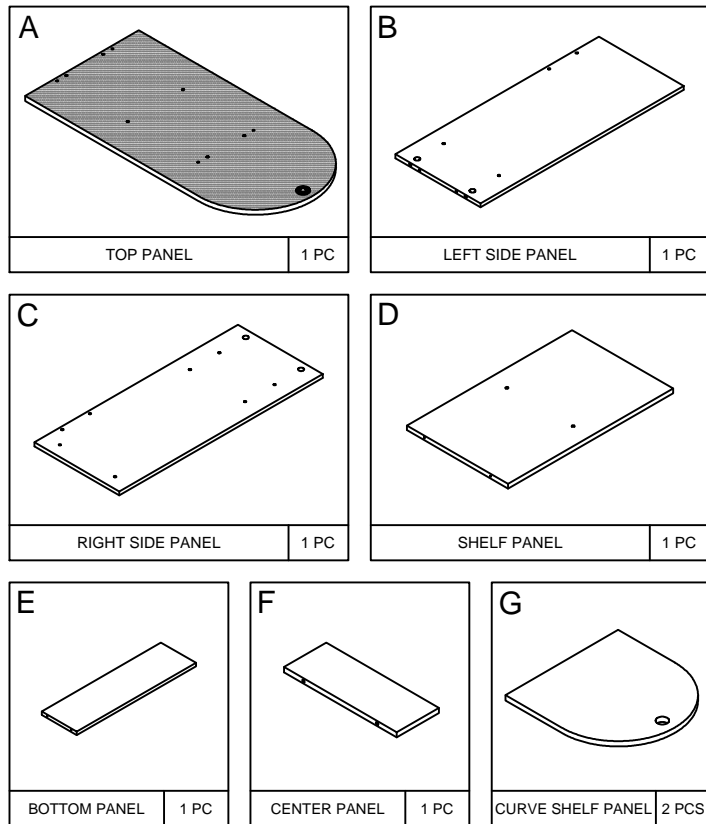

HARDWARE LIST

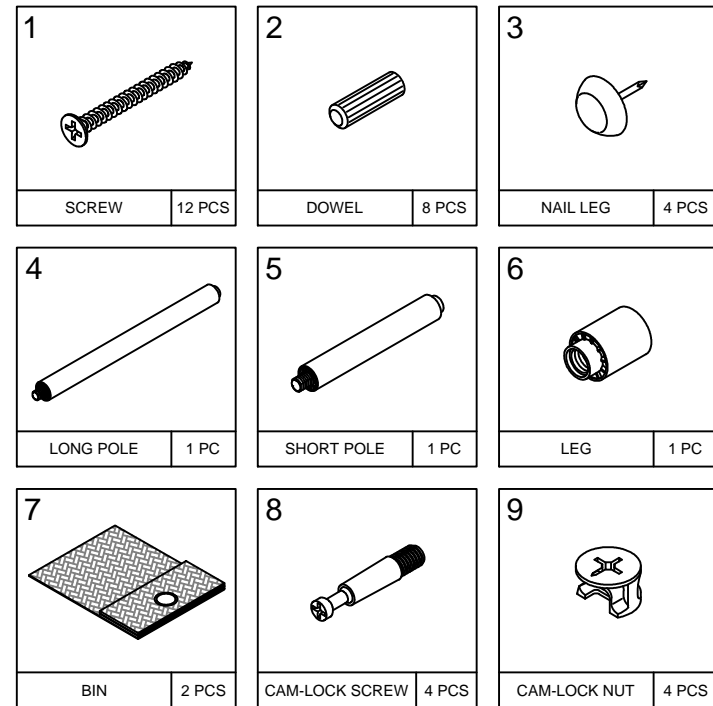

USEFUL HINTS BEFORE YOU START:

1. Read each step carefully before starting.
2. It is important that each step is performed in correct order to avoid difficulties.
3. Identify, soft and count the parts before assembly.
4. Assemble your furniture on packaging cardboard to prevent scratch or damage.
5. Clean the product with mild cleanser using soft damped cloth. Do not use harsh or abrasive cleanser.
6. Using incompatible hardware might cause damage to product.

STEP 9

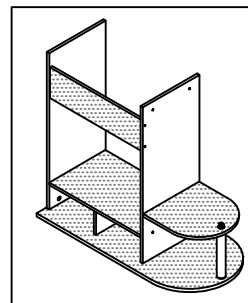

ASSEMBLED UNIT

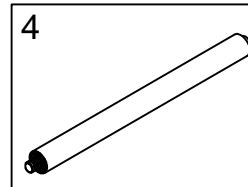

LONG POLE 1 PC

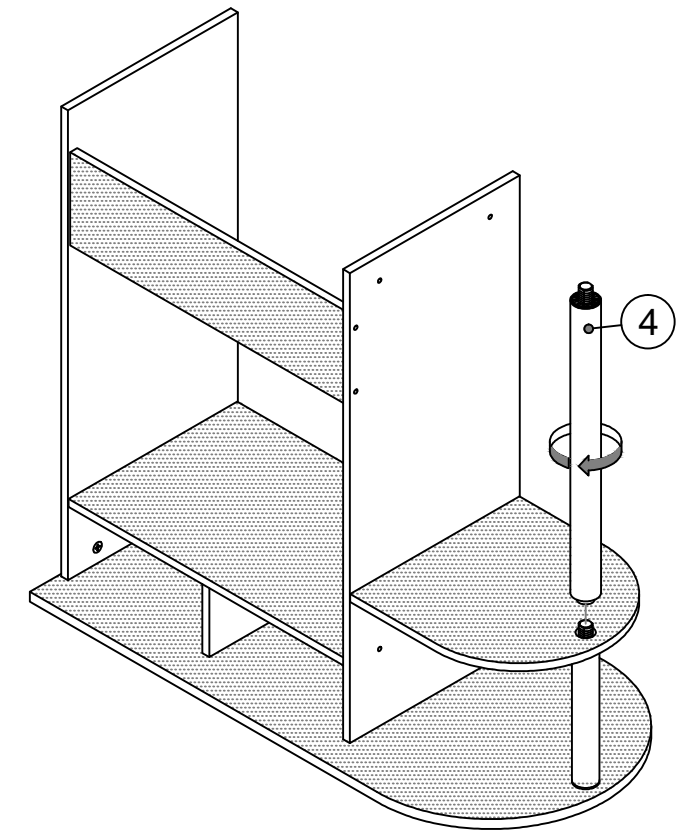

STEP 10

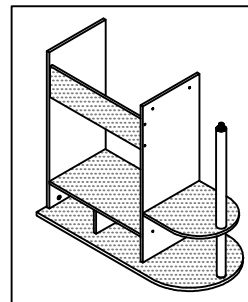

ASSEMBLED UNIT

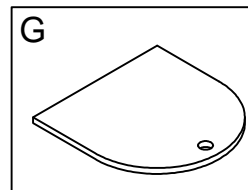

CURVE SHELF PANEL 1 PC

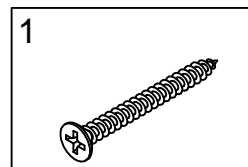

SCREW 2 PCS

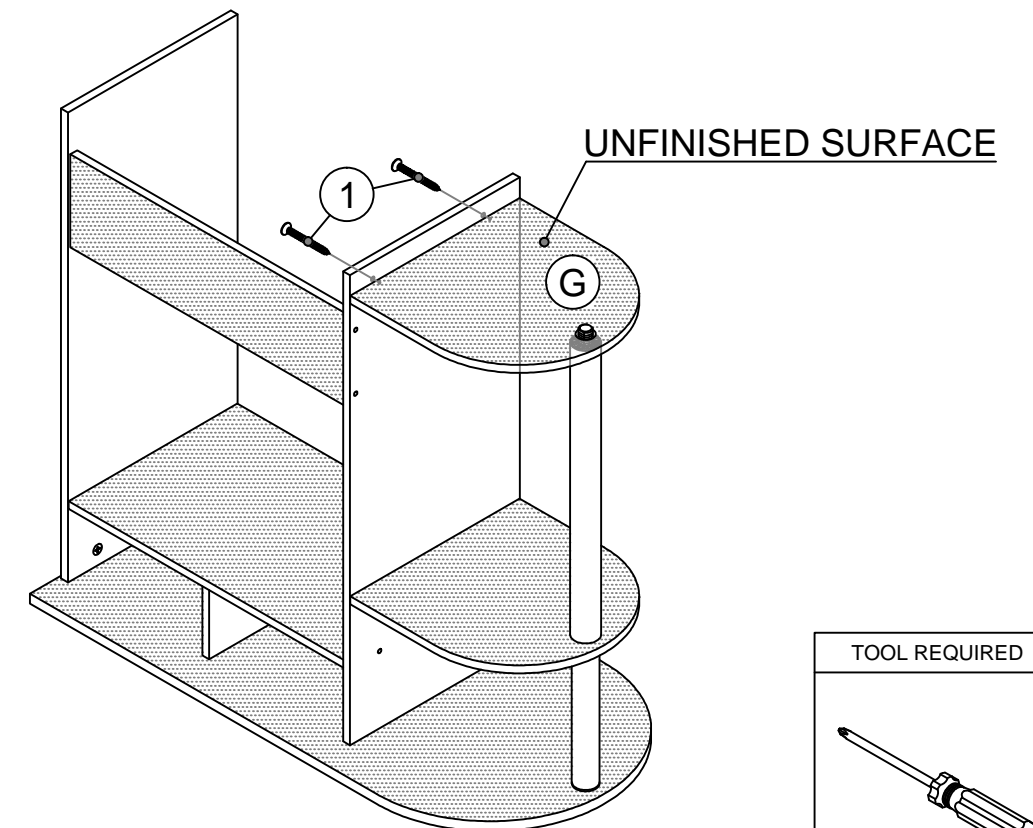

TOOL REQUIRED

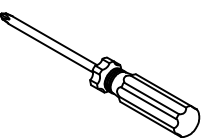

STEP 7

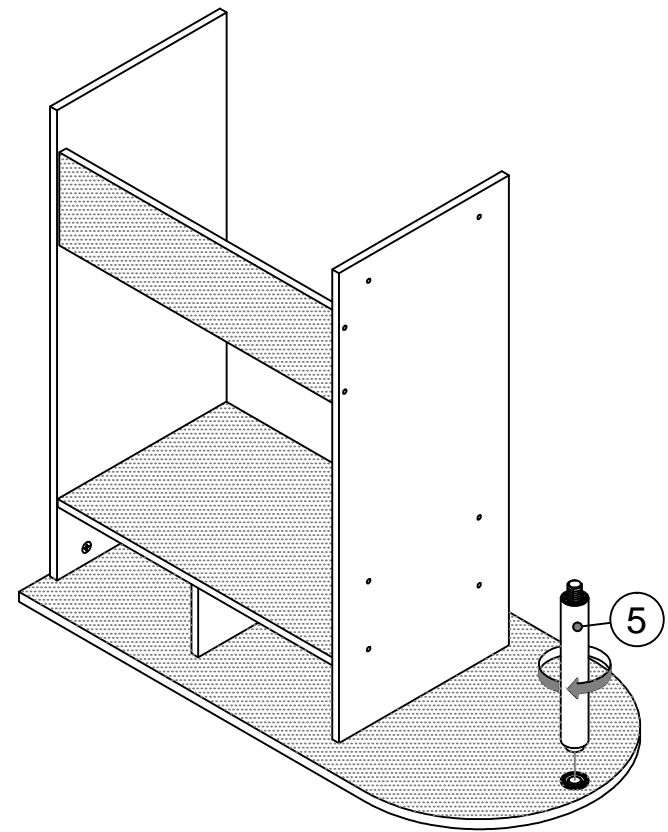
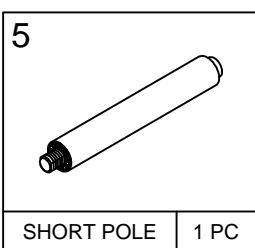
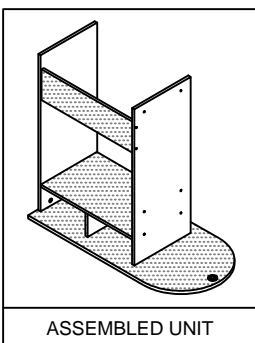

STEP 8

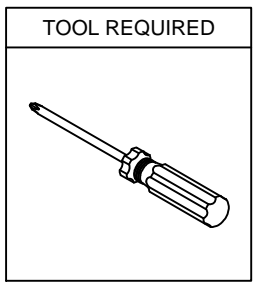
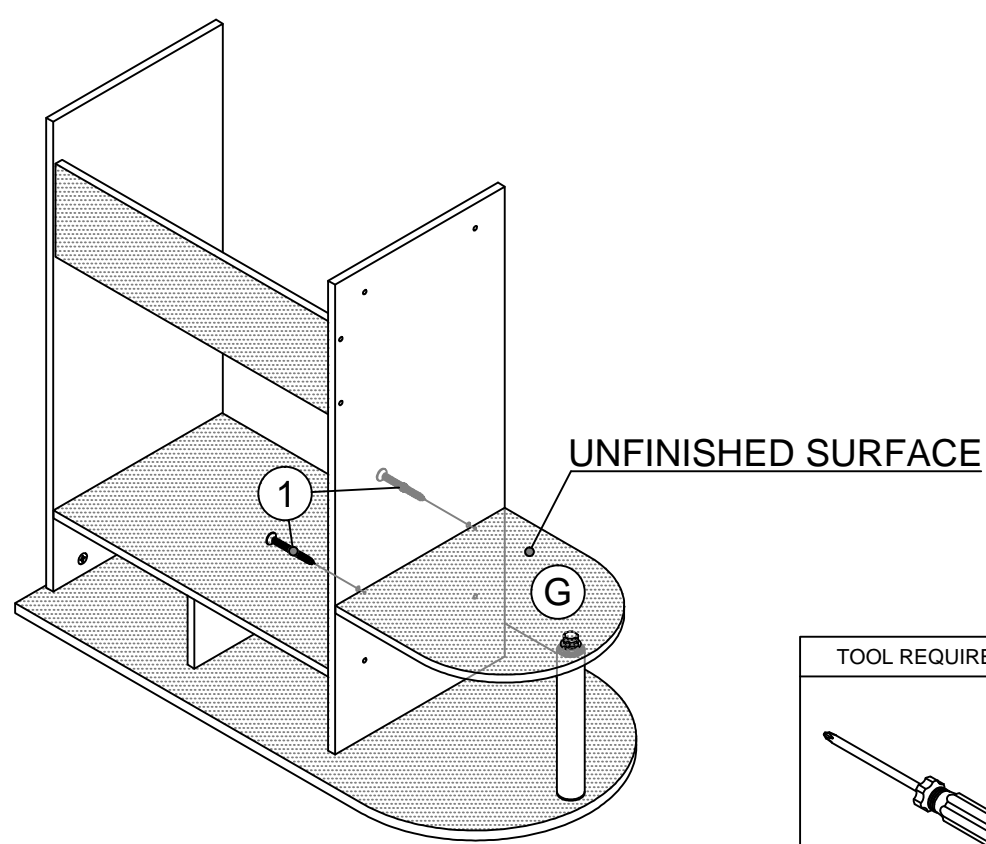
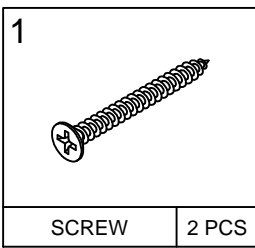
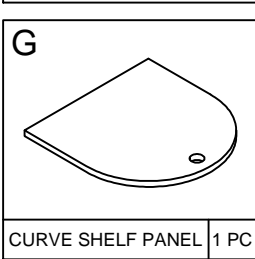
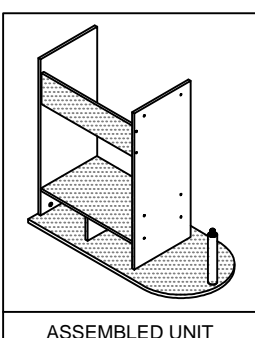

STEP 1

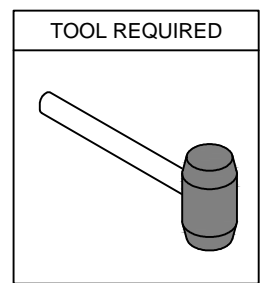
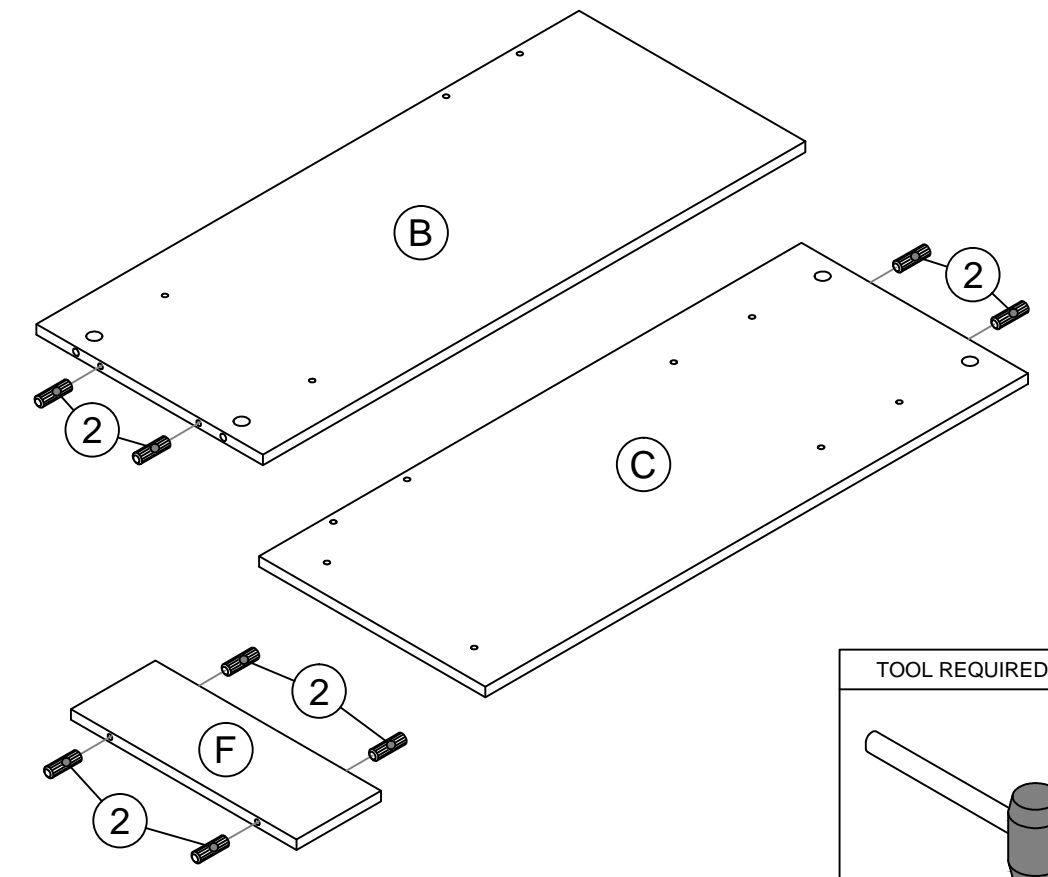
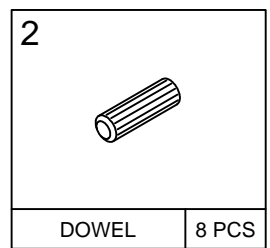
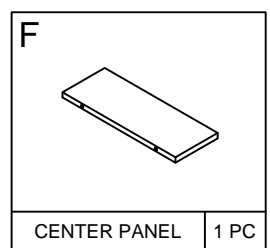
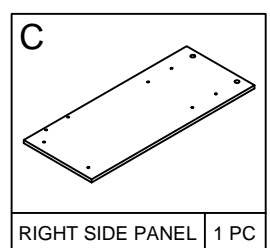
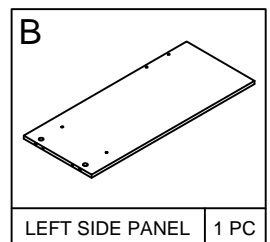

STEP 2

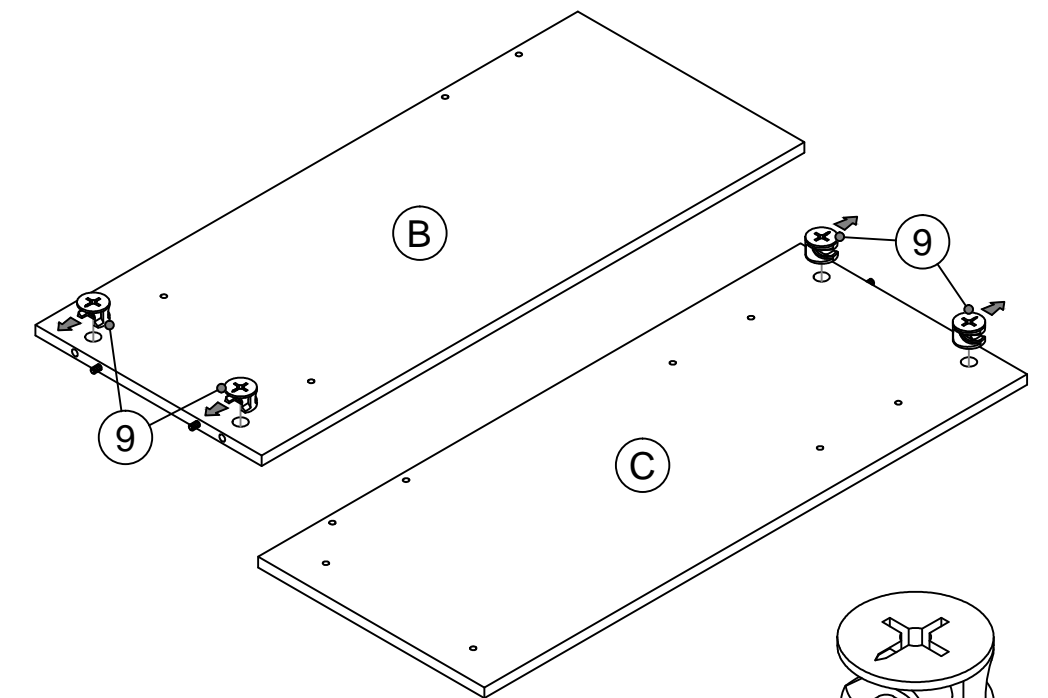
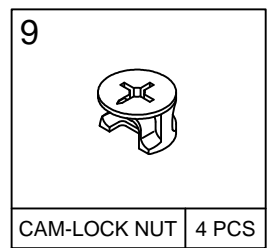
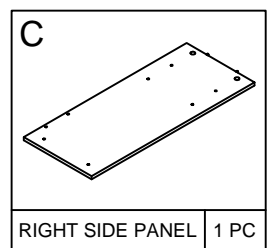
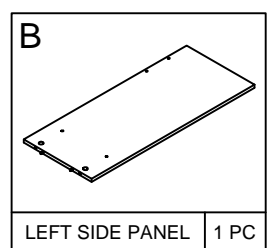

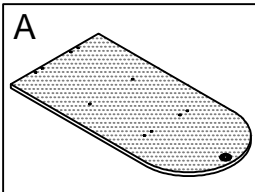

TOP PANEL 1 PC

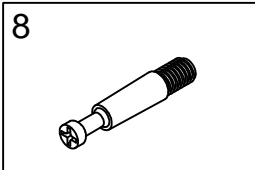

CAM-LOCK SCREW 4 PCS

STEP 3

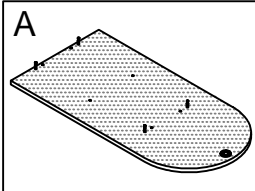
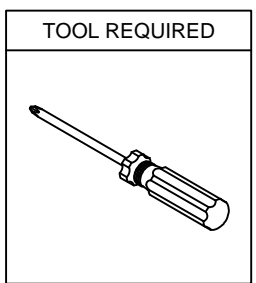
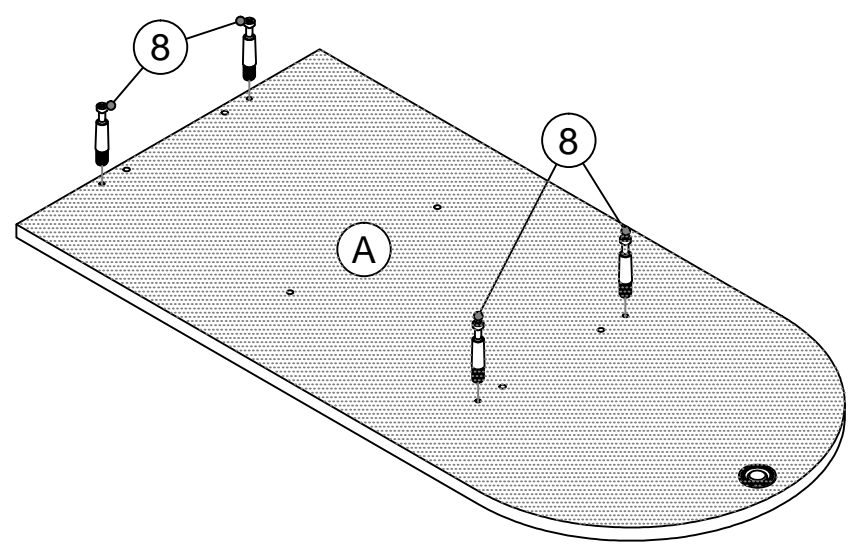

TOP PANEL 1 PC

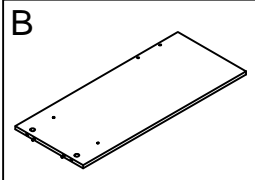

LEFT SIDE PANEL 1 PC

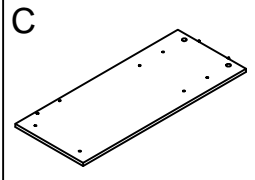

RIGHT SIDE PANEL 1 PC

STEP 4

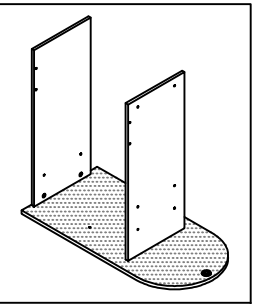
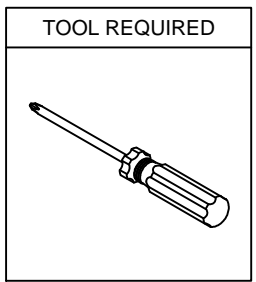
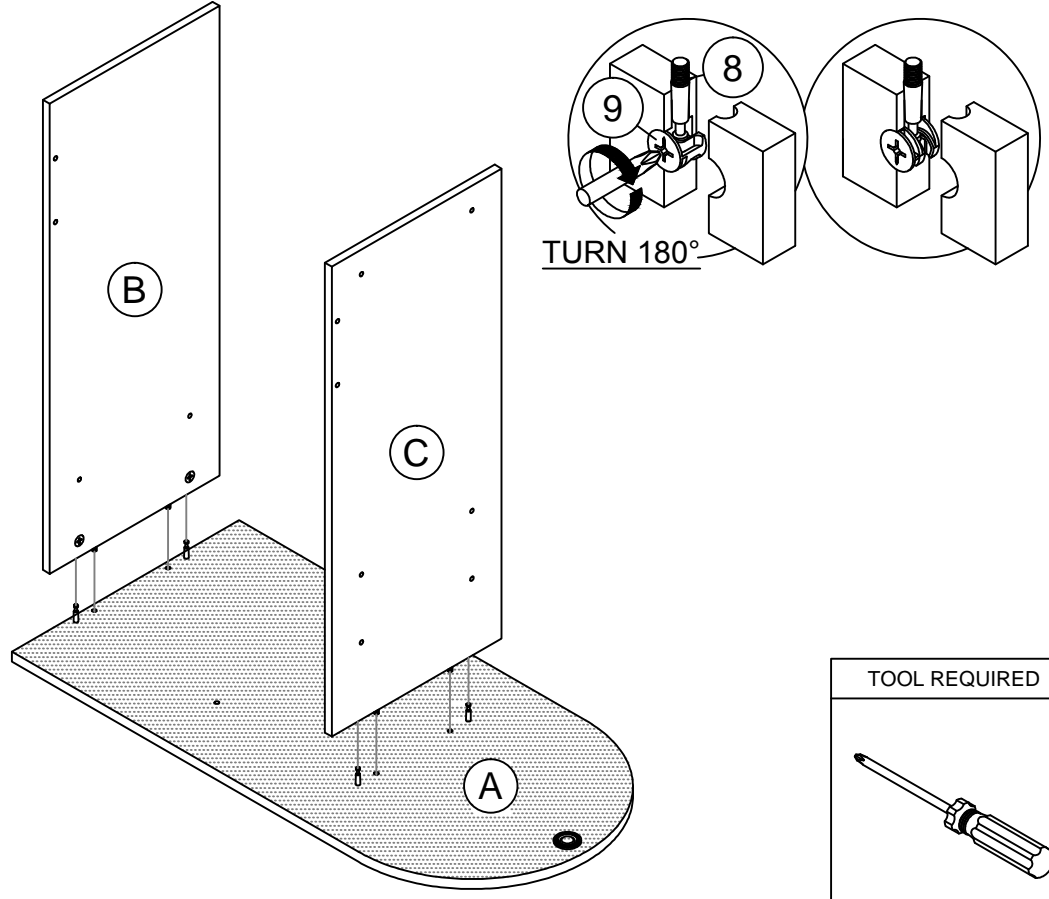

ASSEMBLED UNIT

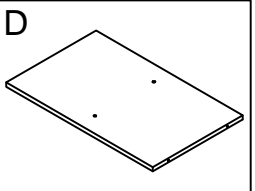

SHELF PANEL 1 PC

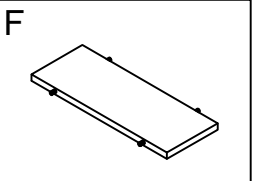

CENTER PANEL 1 PC

STEP 5

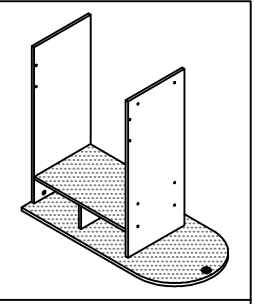
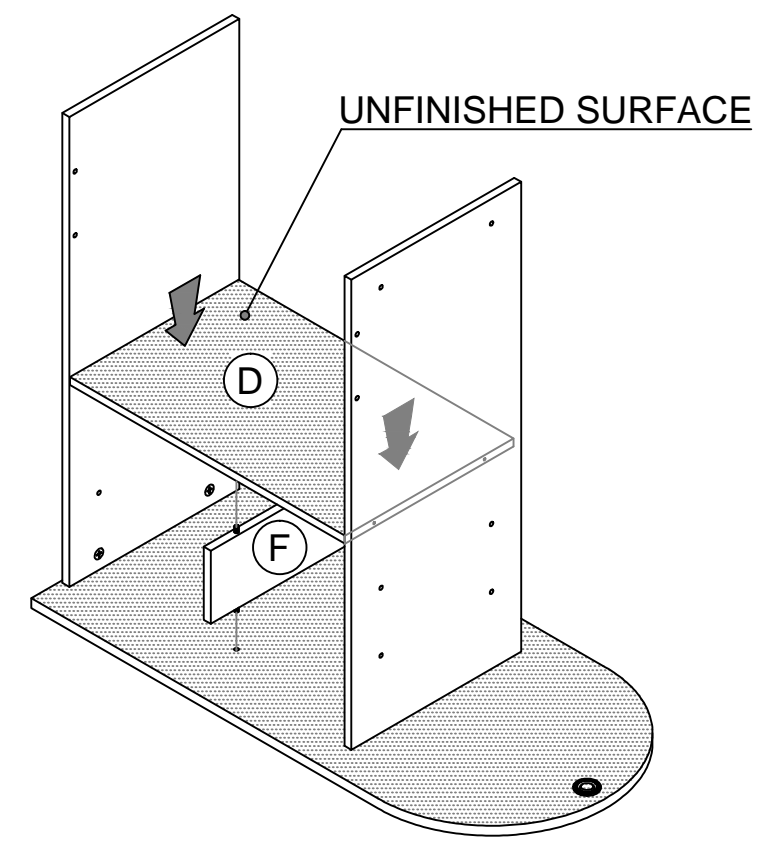

ASSEMBLED UNIT

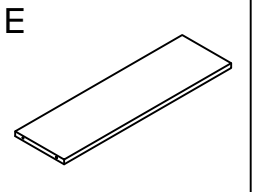

BOTTOM PANEL 1 PC



SCREW 8 PCS

STEP 6

