

WICHTIG - FÜR SPÄTERE VERWENDUNG
AUFBEWAHREN - SORGFÄLTIG LESEN

AVIS - Ces instructions doivent être sauvegardées
Pour utilisation future - Les instructions doivent
être suivies

IMPORTANTE, conservar estas instrucciones
para futuro uso. Siga estas instrucciones atentamente

VIGTIGT - Samvejledningen skal opbevares
i arkiv til senere brug - Skal gennelæses nøje

NOTICE - These instructions must be saved
for future use - Instructions must be followed

TEILCHECKLISTE
 LISTE DE CONTROLE
 LISTADO DE CONTROL
 TJEKLISTE
 CHECK LIST

Réf./No.	Réf./Art.	Qty./Stck./Quantité	Size / Maß / Dimension (mm)	Qty./Stck./Quantité	✓
1		1	47.2"x15.7"x0.7"		
2		1	12.6"x13.9"x0.6"		
3		1	12.6"x13.9"x0.6"		
4		1	47.2"x15.7"x0.7"		
5		1	12.6"x13.2"x0.6"		
6		2	15"x12.2"x0.6"		
7		1	31.3"x13"x0.1"		
8		4	7.9"x2"x2"		
9		2	39.4"x13"x0.5"		

Réf./No.	Réf./Art.	Qty./Stck./Quantité	Size / Maß / Dimension (mm)	Qty./Stck./Quantité	✓
1		1	47.2"x15.7"x0.7"		
2		1	12.6"x13.9"x0.6"		
3		1	12.6"x13.9"x0.6"		
4		1	47.2"x15.7"x0.7"		
5		1	12.6"x13.2"x0.6"		
6		2	15"x12.2"x0.6"		
7		1	31.3"x13"x0.1"		
8		4	7.9"x2"x2"		
9		2	39.4"x13"x0.5"		



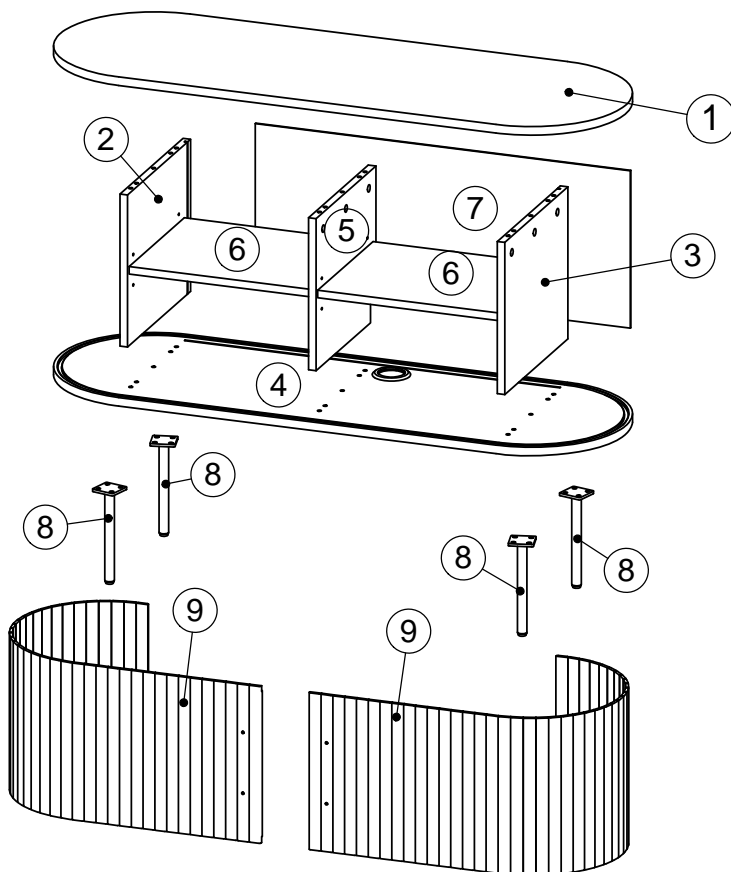



Réf./No.	Réf./Art.	Qty./Stck./Quantité	Size / Maß / Dimension (mm)	Qty./Stck./Quantité	✓
1		1	47.2"x15.7"x0.7"		
2		1	12.6"x13.9"x0.6"		
3		1	12.6"x13.9"x0.6"		
4		1	47.2"x15.7"x0.7"		
5		1	12.6"x13.2"x0.6"		
6		2	15"x12.2"x0.6"		
7		1	31.3"x13"x0.1"		
8		4	7.9"x2"x2"		
9		2	39.4"x13"x0.5"		

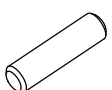

TEILCHECKLISTE - LISTE DE CONTROLE - LISTADO DE CONTROL- TJEKLISTE - CHECK LIST

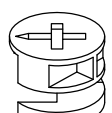
Réf./No.	Réf./Art.	Qty./Stck./Quantité	✓
A		12	
B		9	
C		9	
D		16	
E		9	
F		1	
G		2	
H		4	

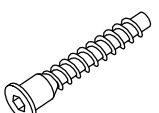
Réf./No.	Réf./Art.	Qty./Stck./Quantité	✓
J		8	
K		8	
N		8	

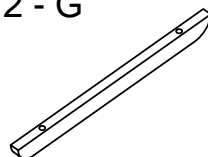
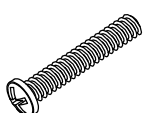
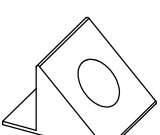
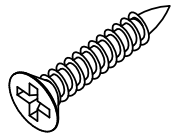
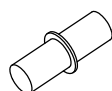
12 - A  Ø 5/16"x1.2"	9 - B  Ø 3/8"x1.7"	9 - C  Ø 19/32"x7/16"	16 - D  M6x5/8"	9 - E  Ø 9/32"x2"	1 - F  5/32"
2 - G  7.1"x19/32"x9/32"	4 - H  M4x5/8"	8 - J 	8 - K  Ø 1/8"x23/32"	8 - N  Ø 3/16"x5/8"	

Geehrter Kunde.
Hier haben Sie die Möglichkeit die mitgelieferten
Schrauben nachzumessen.

Cher Client.
La règle ci jointe vous permet de mesurer la visserie.

Estimado cliente.
aquí podrá medir la tornillería adjunta.

Kære kunde.
Her har De muligheden for at måle medsendte beslag.

Dear Customer.
Below you have the opportunity to measure the
Enclosed Hardware.

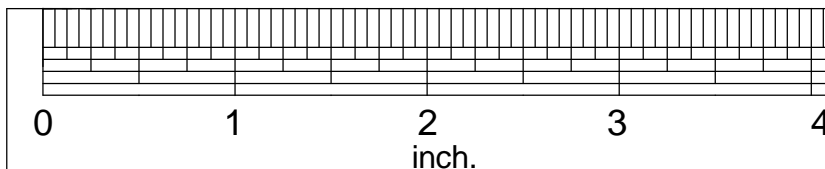

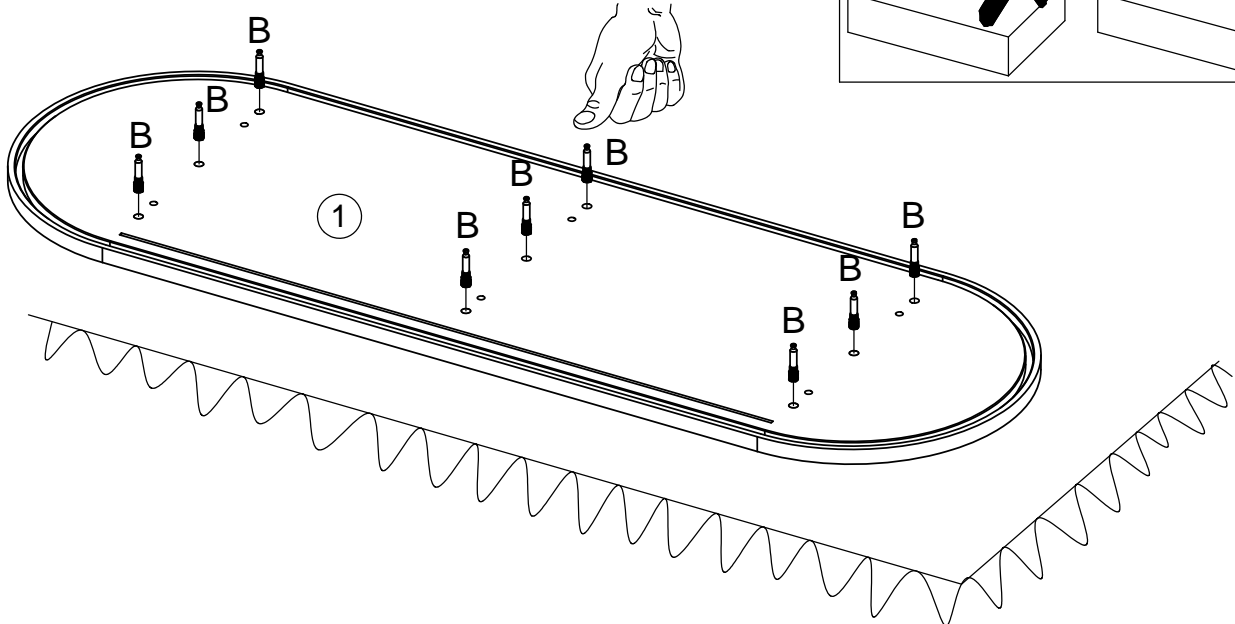
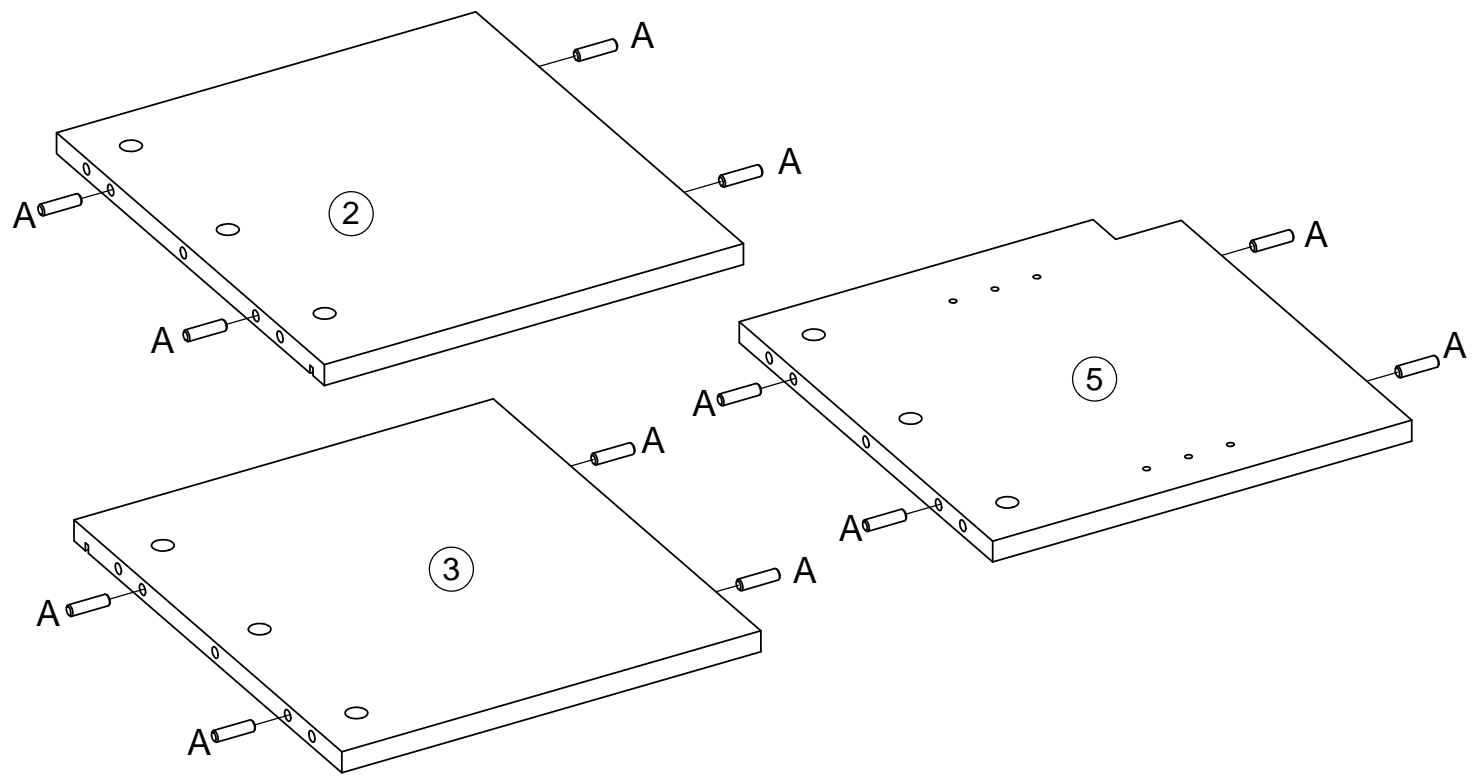

3 9 - C 

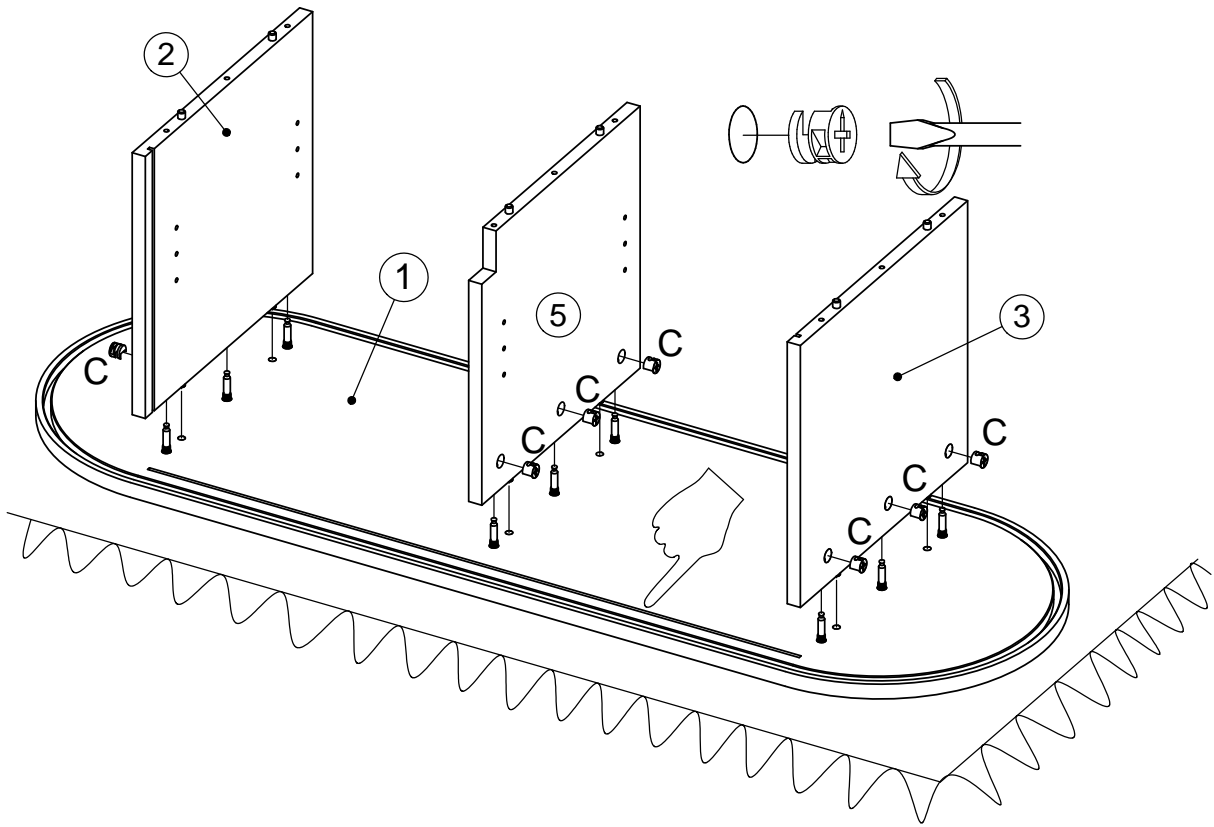

4 

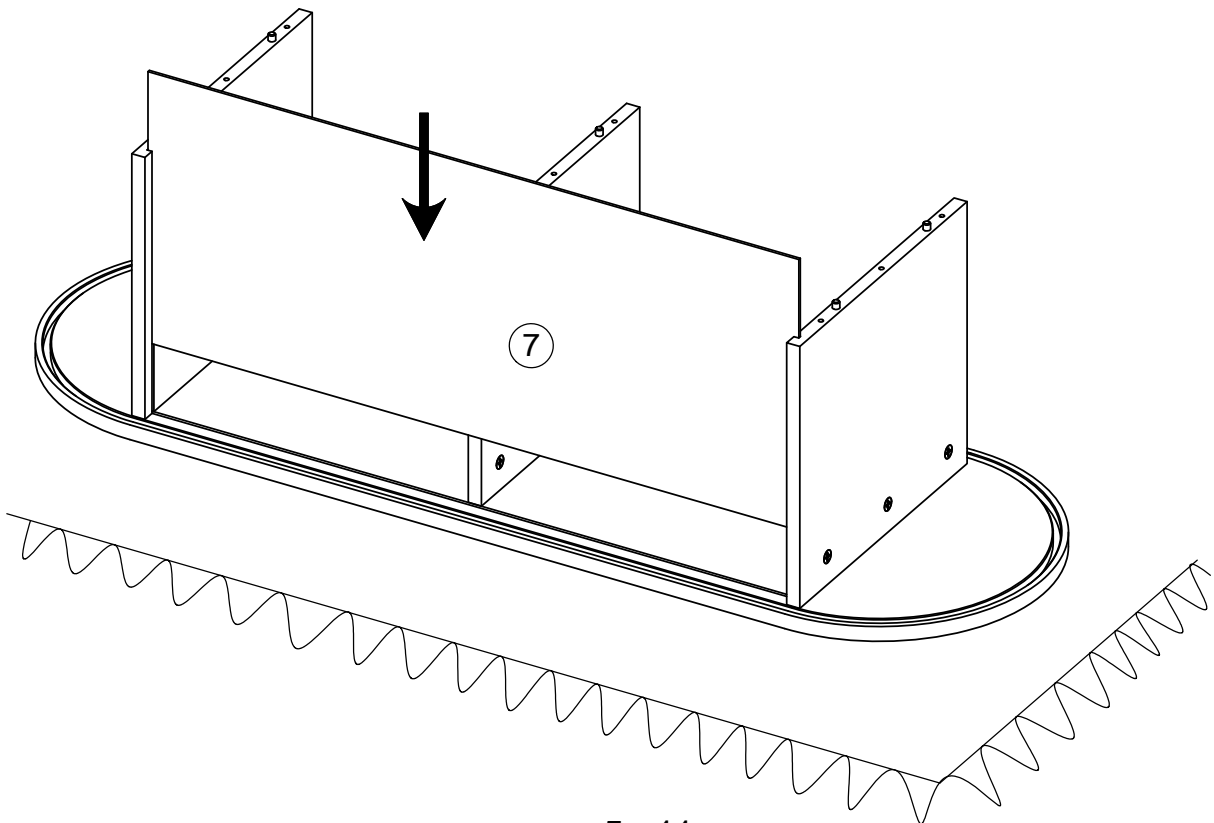

5 9 - E 1 - F

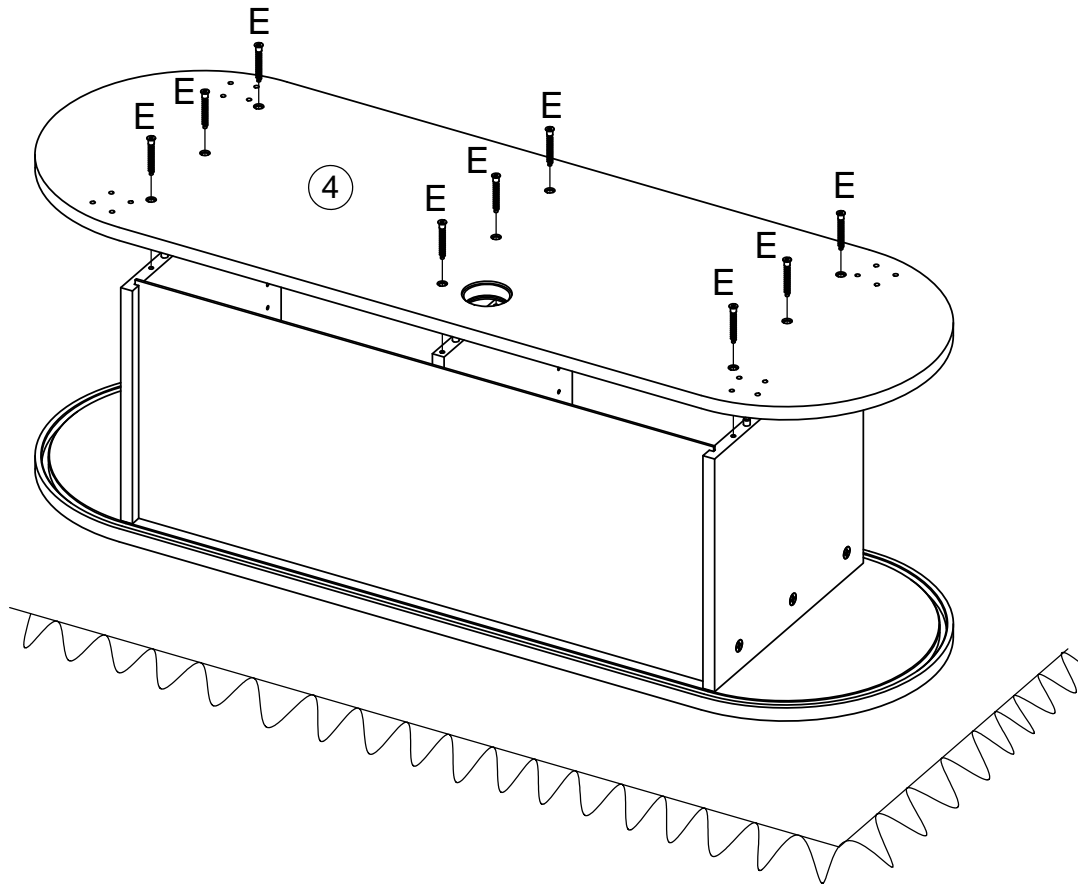
6 8 - J 8 - K

7 16 - D  

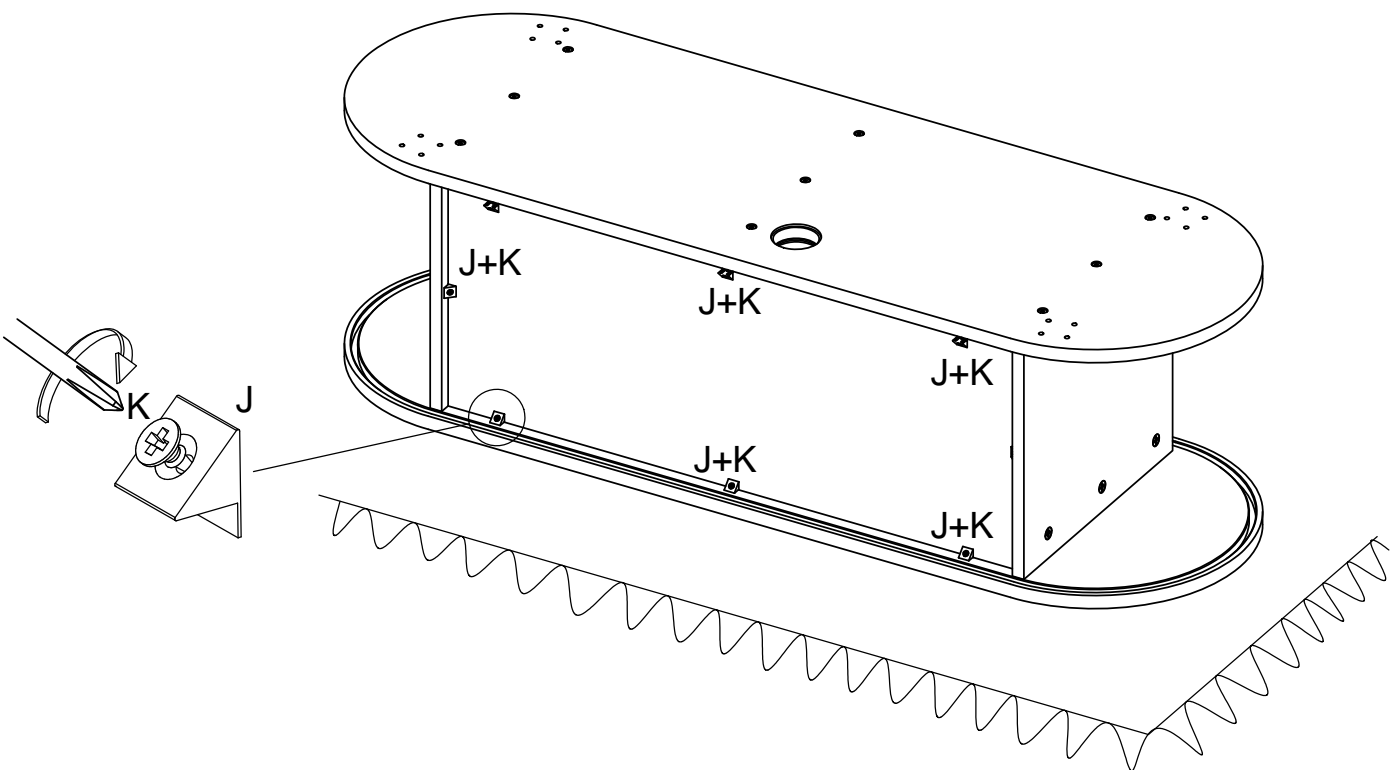

8 2 - G 4 - H  

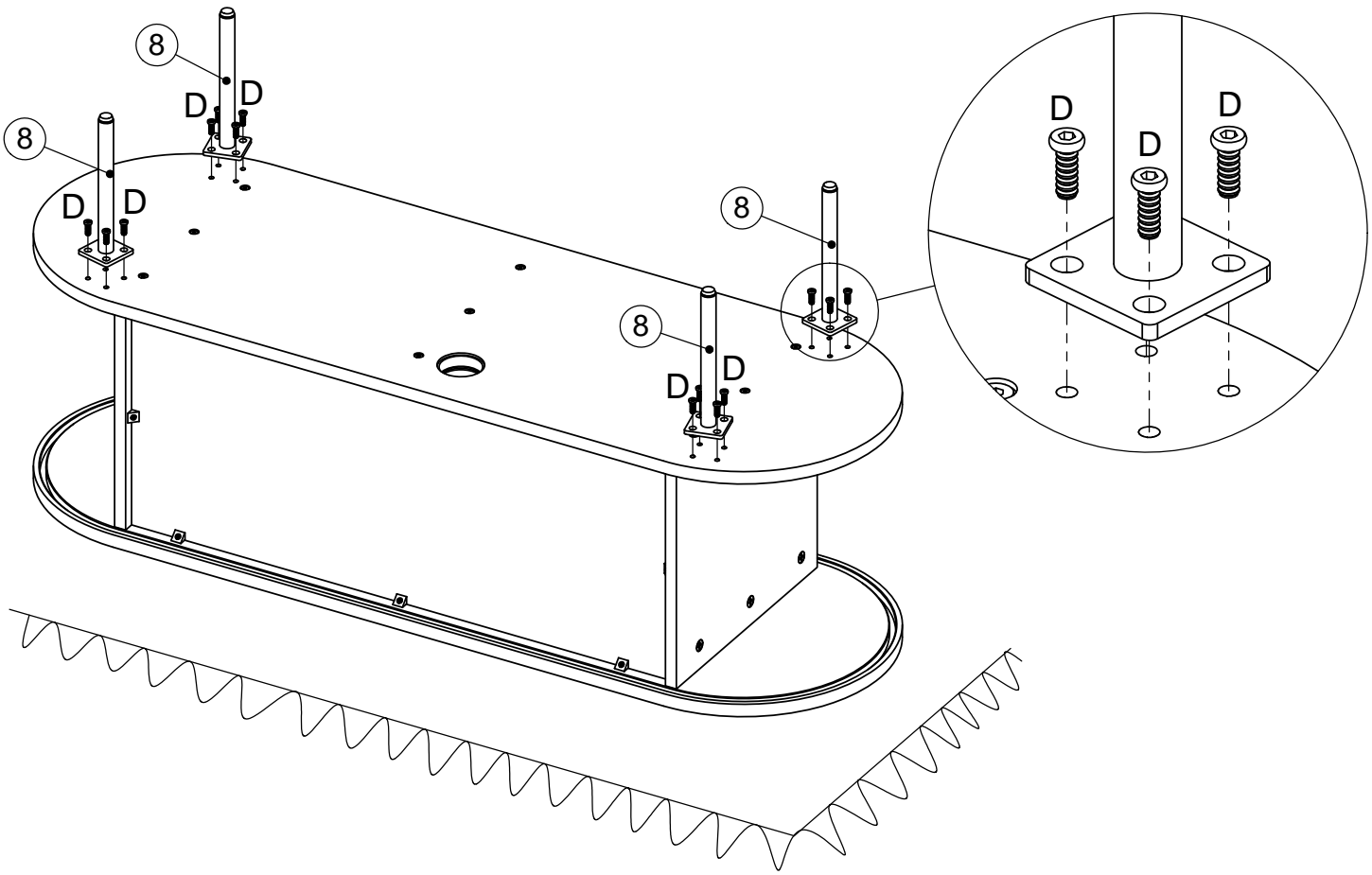

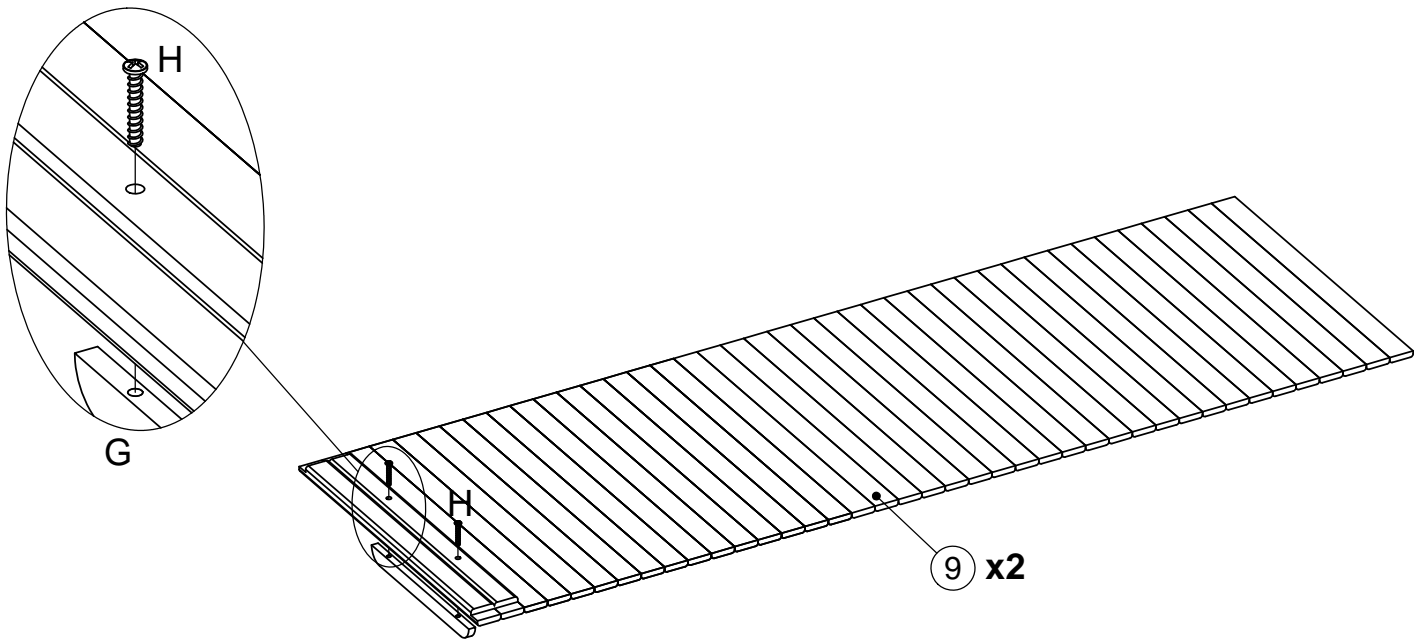
9

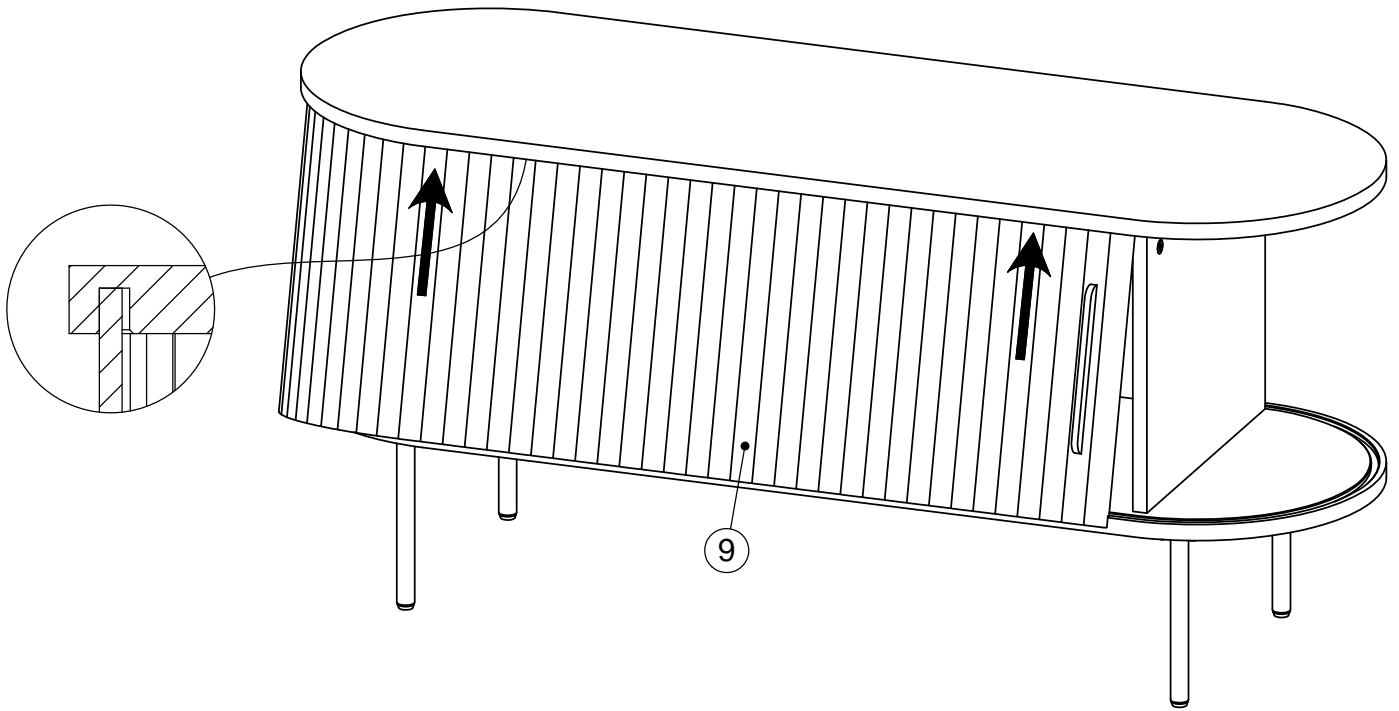

10

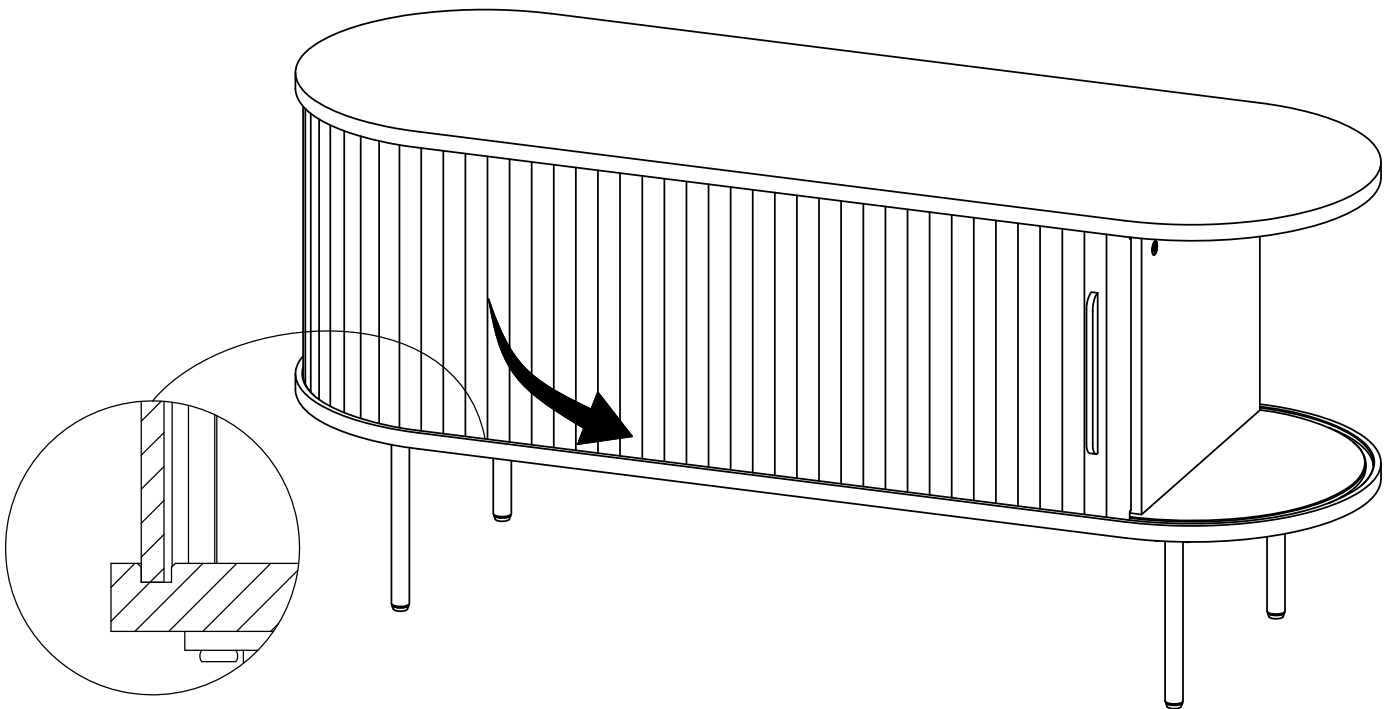

11

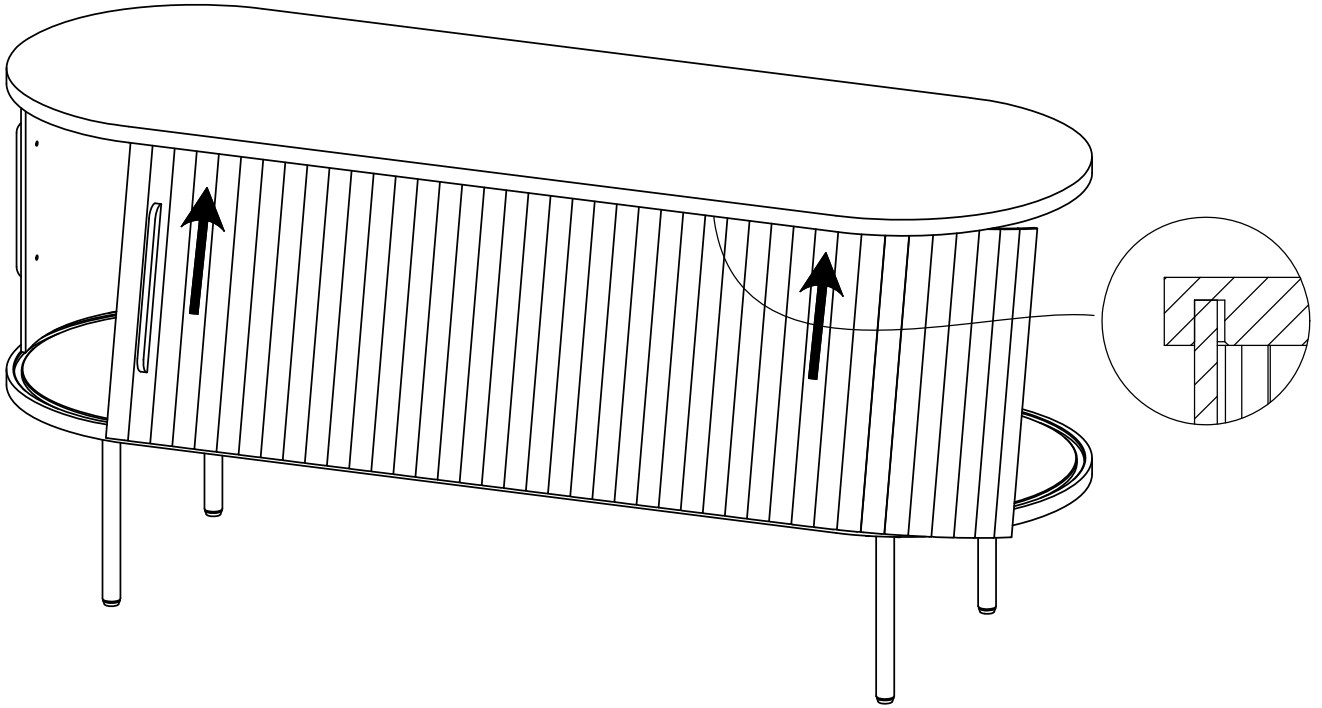

12

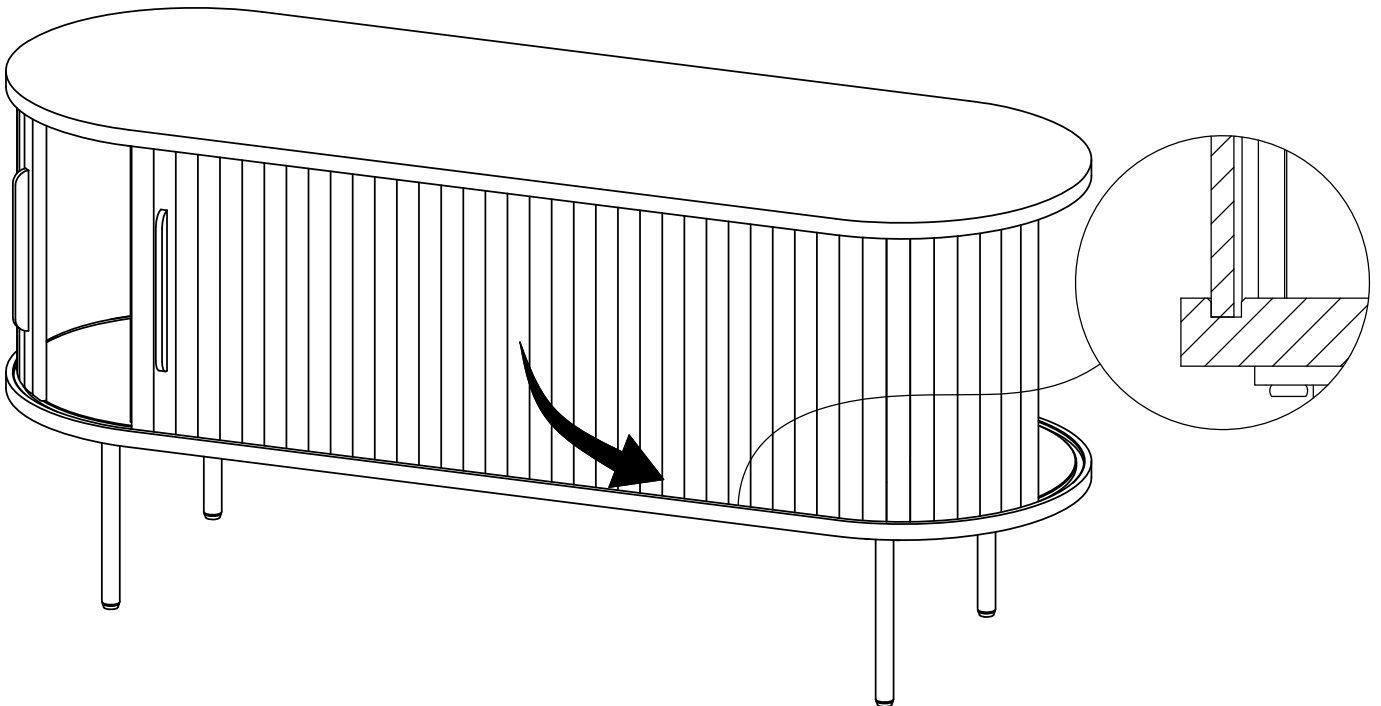

13 8 - N

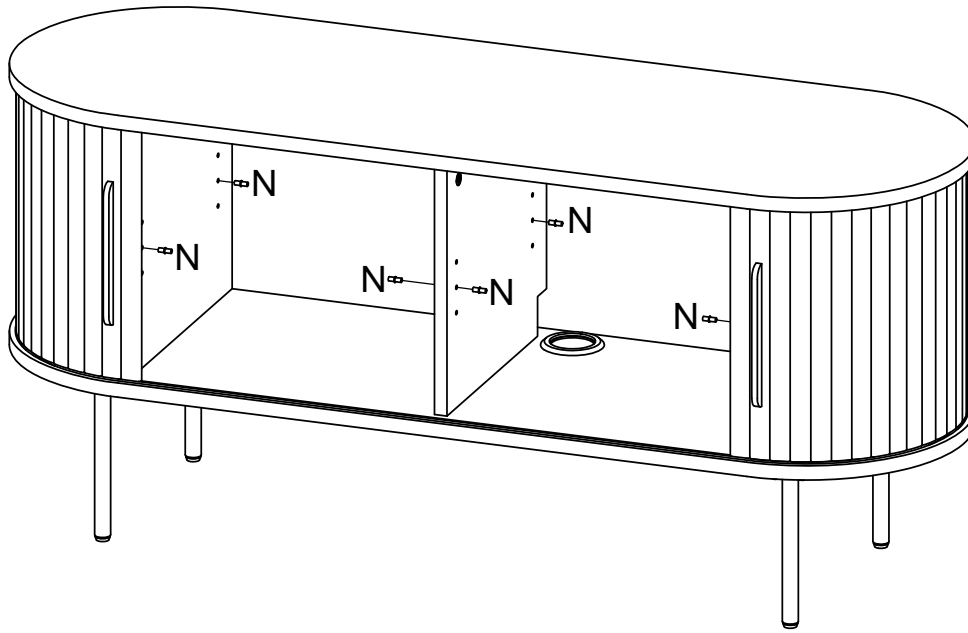

14

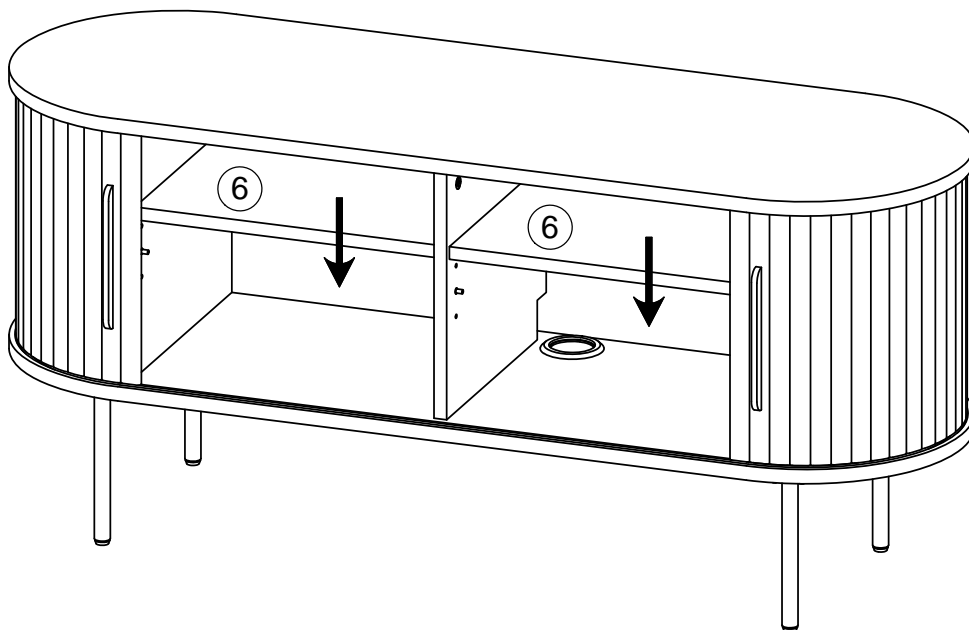

14

