





ASSEMBLY INSTRUCTIONS & PARTS IDENTIFICATION EXT TABLE

Thank you for purchasing this quality product. Be sure to check all packing material carefully for small parts that may have come loose inside the carton during shipment

Key Parts			
No	Code	Qty	Description
1	A	1 pc	Table Top
2	B	4 pcs	Table Leg
3	C	1 pc	Apron spacer
4	D	4 pcs	Floor Glide
5	E	2 set	Extension Mechanism
6	F	4 set	Extension Lock

Hardware kit (1702-42P01)			
No		Description	Q'Ty
A		Hexa Nut Ø8	8 pcs
B		Lock Washer Ø8.5	8 pcs
C		Flat Washer Ø8.5	8 pcs
D		Key Wrench	1 pc

PLEASE NOTE:

Assembly of this table requires two people

STEP 1

- Carefully lay Table Top upside down on a smooth flat surface to prevent scratches.
- Affix each Leg to each corner of the Table Top as shown in illustration. Insert a Flat Washer, Lock Washer and Nut on the bolts of each Leg
- Once all Legs are in place, fully tighten nuts by turning clockwise using provided Key Wrench until secure. (See Detail A)

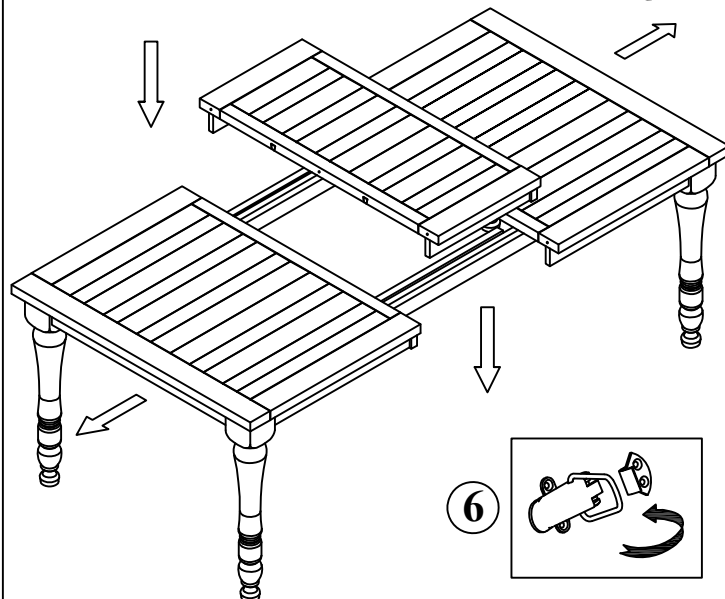
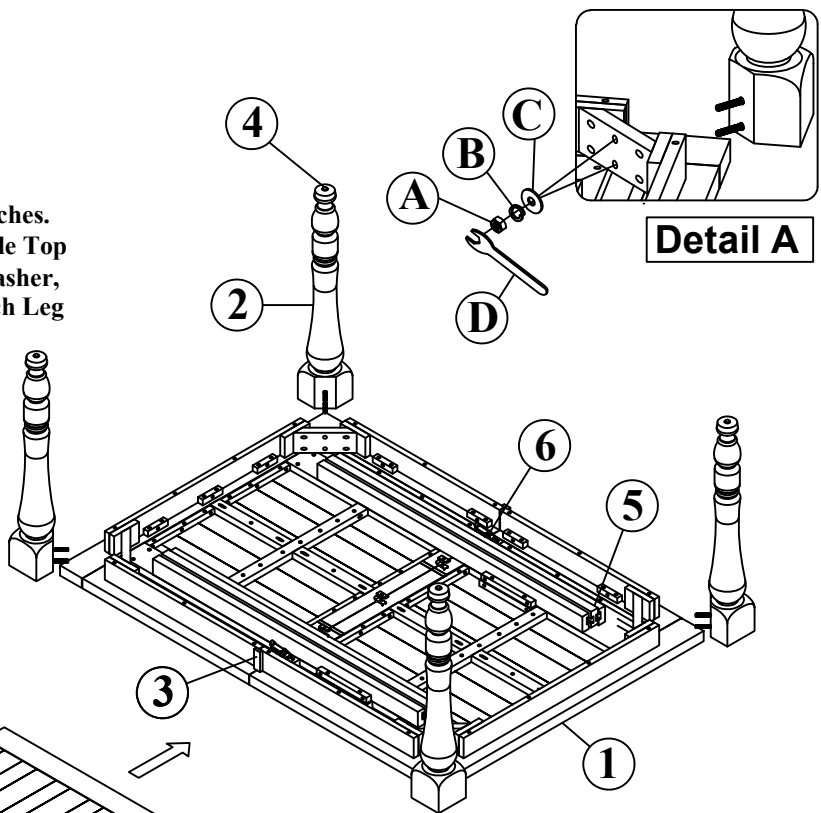

STEP 2

Fully extend both sides of the table and carefully place the removable leaf in place lining up the pins and holes with the table top. Reverse procedure for storage.