

ASSEMBLY INSTRUCTIONS

CAUTION: PLEASE READ ALL INSTRUCTIONS BEFORE STARTING THE ASSEMBLY OF THIS PRODUCT.
THESE PIECES ARE HEAVY.

IN ORDER TO PREVENT PERSONAL INJURY AND ENSURE THAT THIS PRODUCT IS NOT
DAMAGED DURING THE ASSEMBLY PROCESS. IT IS STRONGLY RECOMMENDED THAT YOU
ENLIST THE ASSISTANCE OF ONE OR MORE PEOPLE.
IN CASE OF EXCESS STAIN, WIPE THE BOTTOM OF THE UNIT BEFORE PLACING ON ANY
SURFACE.

ATTENTION: VEUILLEZ LIRE TOUTES LES INSTRUCTIONS AVANT DE COMMENCER L'ASSEMBLAGE DE CE
PRODUIT. LES PIECES SONT LOURDES. POUR EVITER TOUTE BLESSURE ET POUR VOUS
ASSURER QUE LE PRODUIT N'EST PAS ENDOMMAGE' PENDANT
L'ASSEMBLAGE, NOUS VOUS RECOMMANDONS DE FAIRE APPEL A UNE OU PLUSIEURS
AUTRES PERSONNES.
EN CAS DE TACHE EXCESSIVE, ESSUYEZ LE FOND DE L'UNITÉ AVANT LE PLACEMENT SUR
N'IMPORTE QUELLE SURFACE.

CUIDADO: FAVOR DE LEER TODAS LAS INSTRUCCIONES ANTES DE ENSAMBLAR SU PRODUCTO, ESTAS
PIEZAS SON PESADAS.
PARA PREVENIR HERIDAS PERSONALES Y ASEGURAR QUE SU PRODUCTO NO SEA DAÑADO
MIENTRAS ES ENSAMBLADO. SE RECOMIENDA LA ASISTENCIA DE UNA O MAS PERSONAS.

WARNING.....PROTECTIVE GLIDE IS PLACED UNDER LEGS OF FURNITURE TO RESIST SCRATCHES TO
FLOOR SURFACE. SOME FLOOR SURFACES CAN BE EXTRA SENSITIVE TO MARKING, IF YOU ARE NOT SURE
CONSULT WITH YOUR DEALER.

AVERTISSEMENT...LES PIEDS DES MEUBLES SONT MUNIS DE PATINS DESTINES A PROTEGER LE PLANCHER.
CERTAINS REVETEMENTS DE SOL PEUVENT ETRE TRES FRAGILES. EN CAS DE DOUTE. CONSULTER LE
MARCHAND.

ASSEMBLY INSTRUCTIONS

Step 1

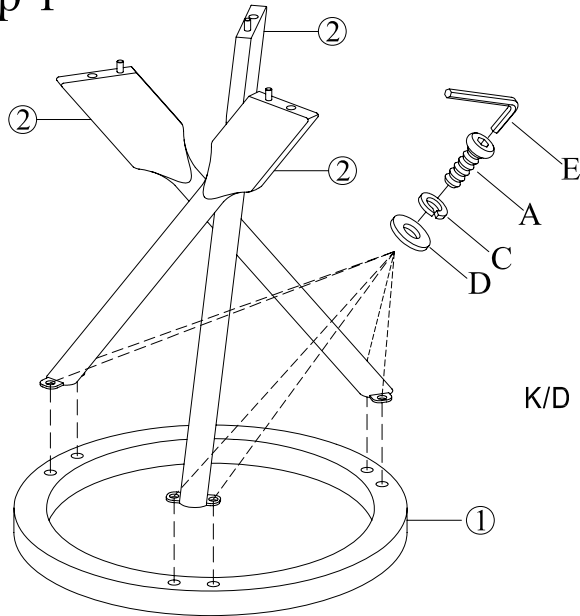

Step 2

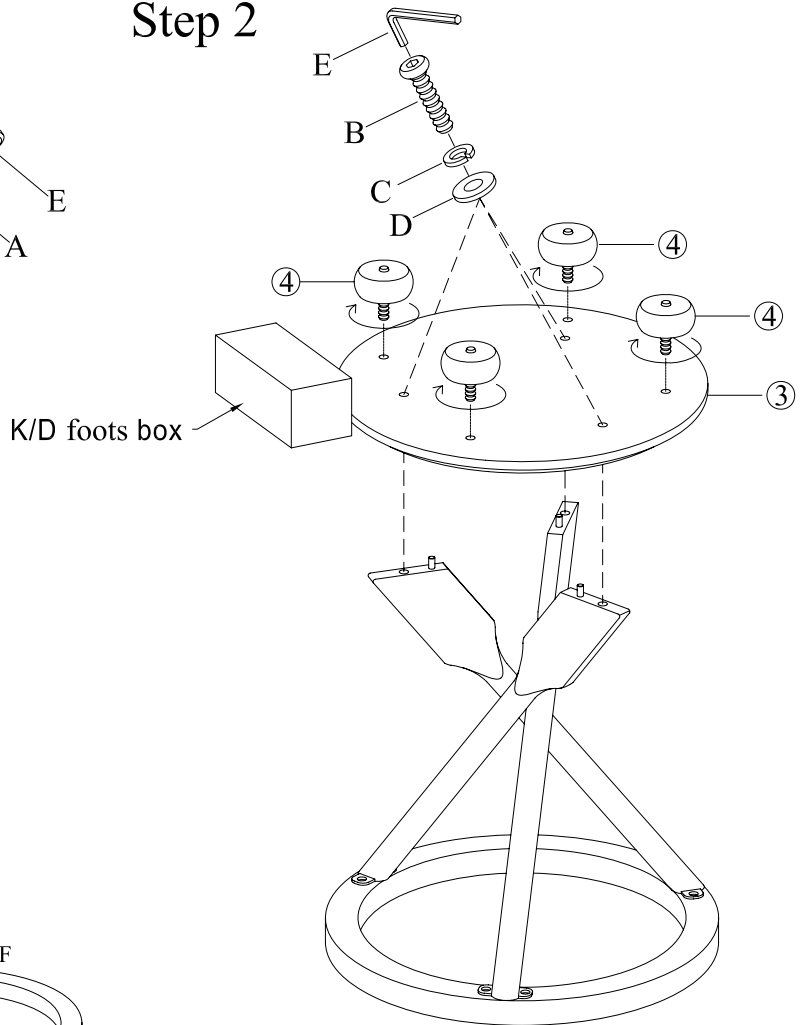

Step 3

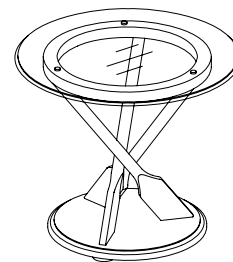
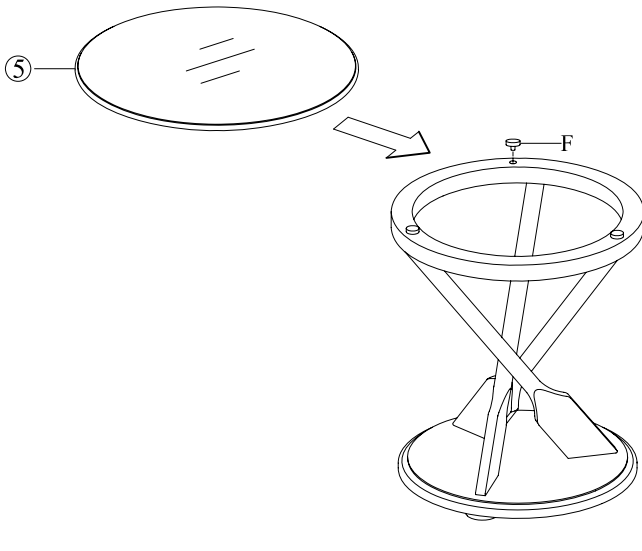

LIST OF PARTS AND ARDWARE:

No.	Description	Q'ty
A	Bolt Ø1/4"*5/8"	6 PCS
B	Bolt Ø1/4"*1-3/4"	3 PCS
C	Lock Washer Ø1/4"	9 PCS
D	Flat Washer Ø1/4" *16	9 PCS
E	Allen Wrench 4mm	1 PC
F	Glass Bumper	3 PCS

LIST OF PARTS AND ARDWARE:

No.	Description	Q'ty
1	Top	1 PC
2	Leg	3 PCS
3	Shelf	1 PC
4	Foot	4 PCS
5	Glass	1 PC

ASSEMBLY INSTRUCTIONS

Step 1

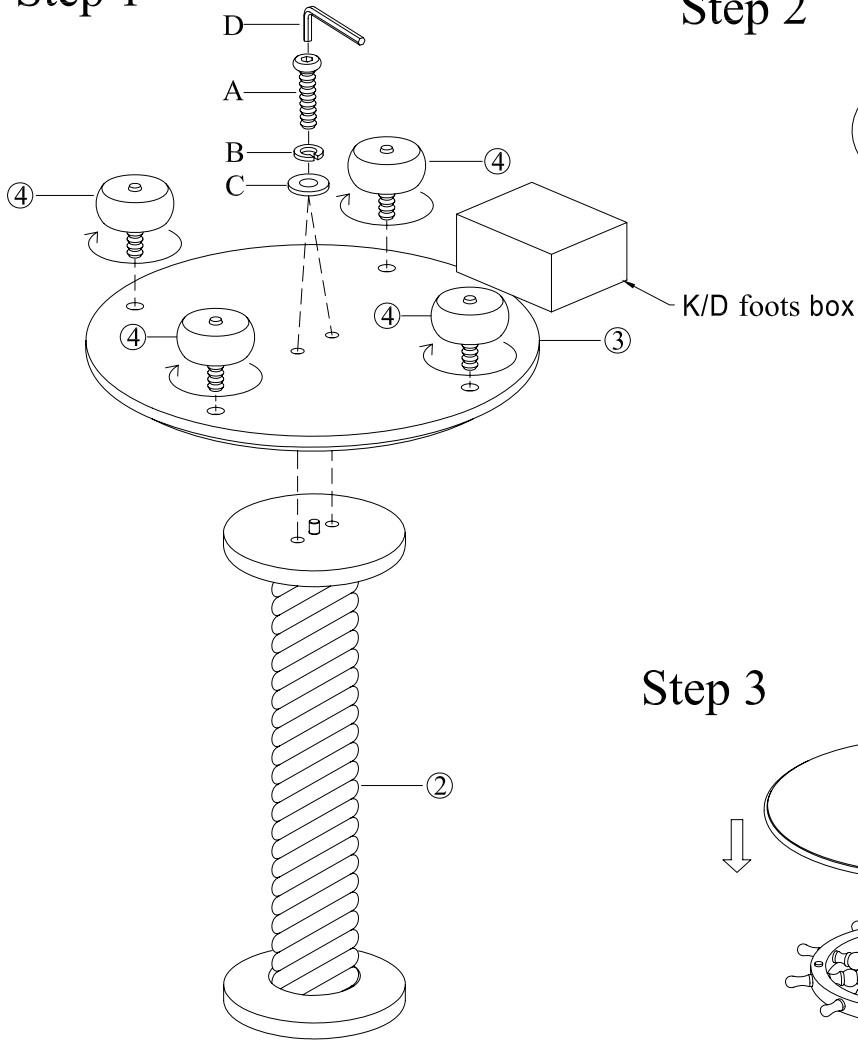

Step 2

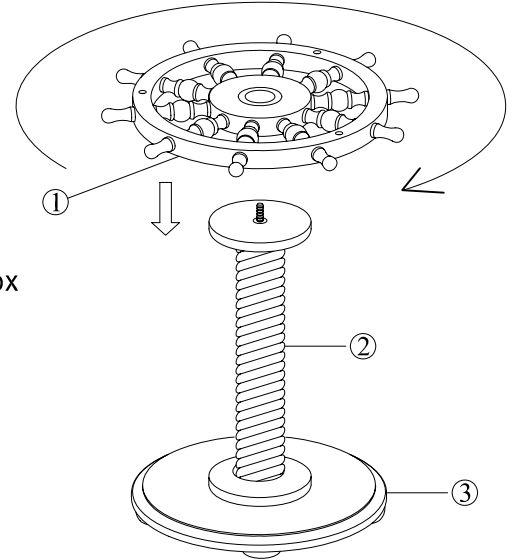

Step 3

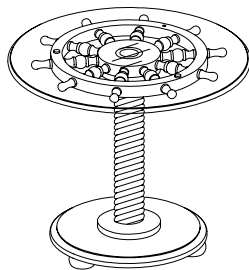
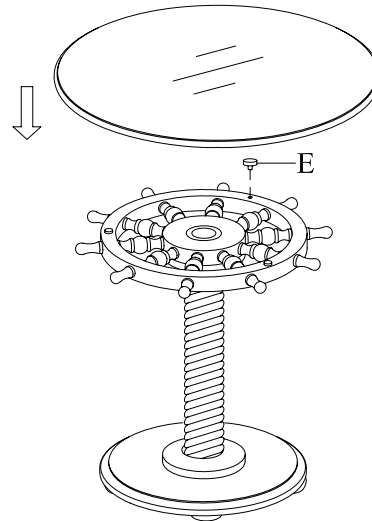

LIST OF PARTS AND ARDWARE:

No.	Description	Q'ty
A	Bolt Ø1/4"*1-3/4"	2 PCS
B	Lock Washer Ø1/4"	2 PCS
C	Flat Washer Ø1/4" *16	2 PCS
D	Allen Wrench 1/4"	1 PC
F	Glass Bumper	3 PCS



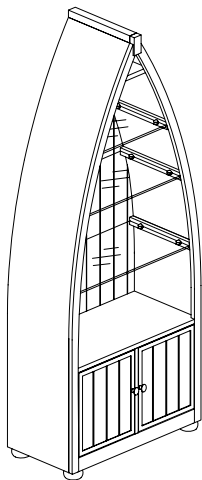
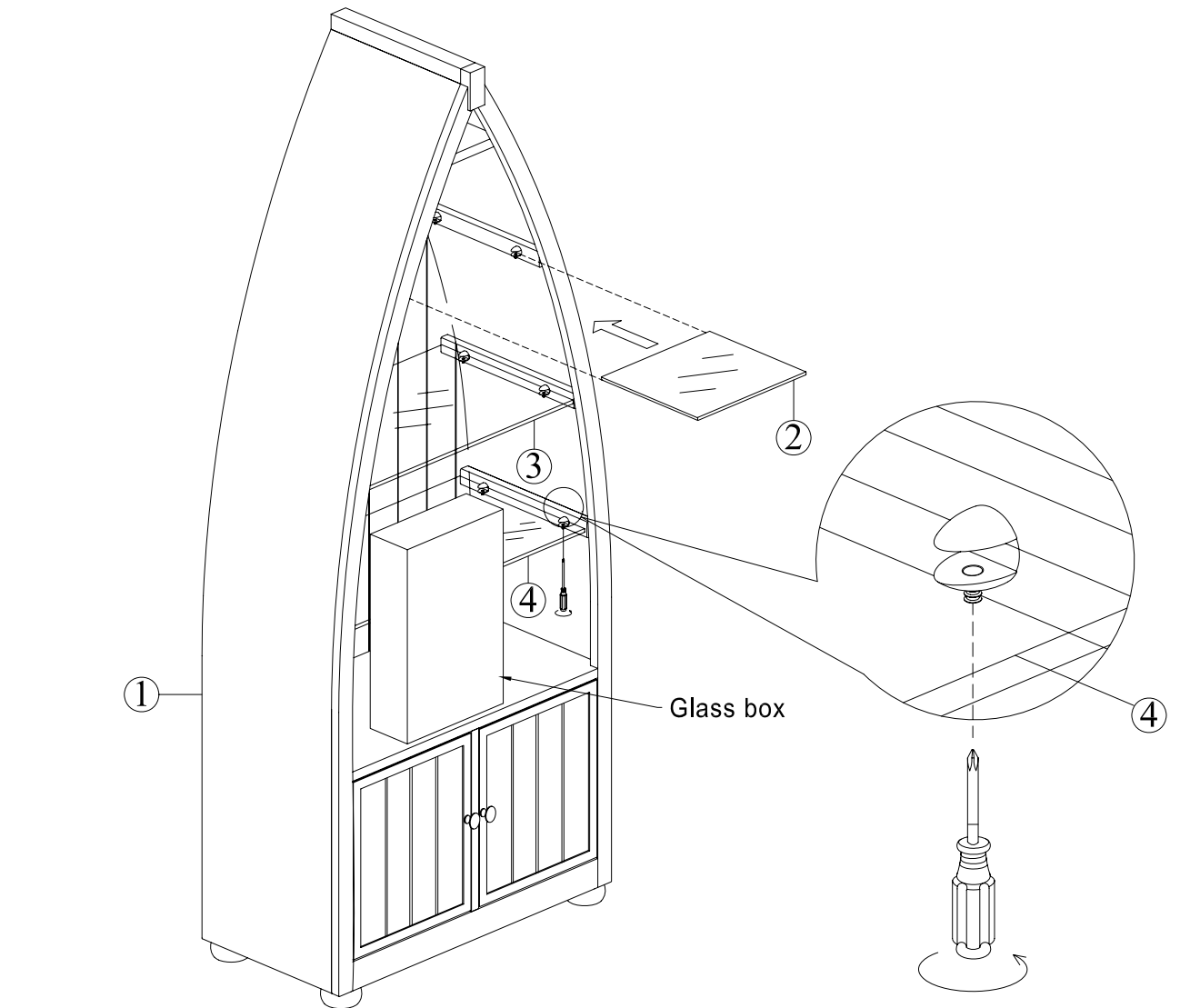

LIST OF PARTS AND ARDWARE:

No.	Description	Q'ty
1	Top	1 PC
2	Post	1 PC
3	Shelf	1 PC
4	Foot	4 PCS
5	Glass	1 PC

ASSEMBLY INSTRUCTIONS

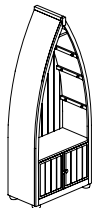



LIST OF PARTS AND ARDWARE:			
No.	Description		Q'ty
A	Glass Bumper		4 PCS

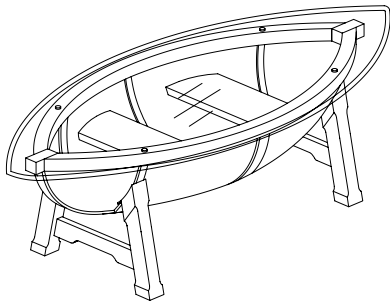
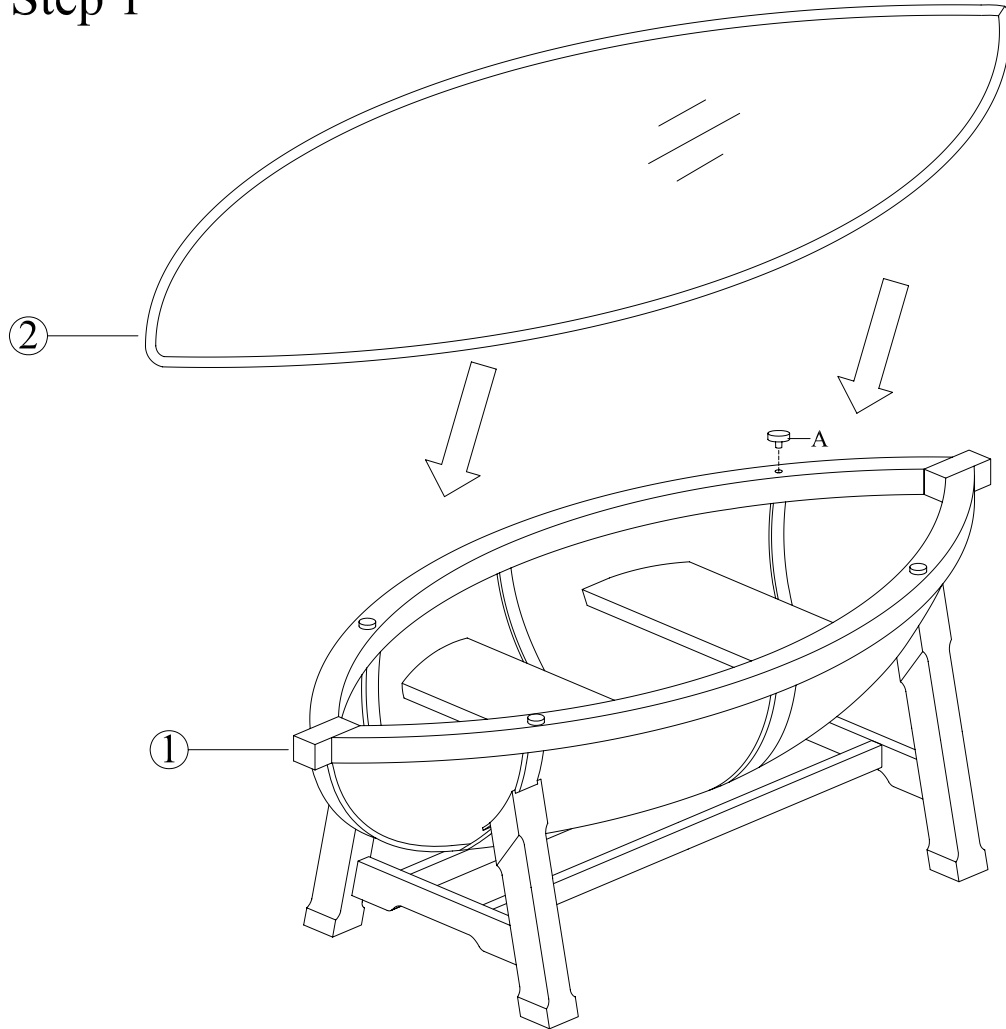

LIST OF PARTS AND ARDWARE:				
No.	Description			Q'ty
1				1 PC
2	Small Glass Shelf			1 PC
3	Middle Glass Shelf			1 PC
4	Large Glass Shelf			1 PC

ASSEMBLY INSTRUCTIONS

Step 1

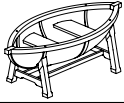

LIST OF PARTS AND ARDWARE:			
No.	Description		Q'ty
A	Glass Bumper		8 PCS

LIST OF PARTS AND ARDWARE:				
No.	Description			Q'ty
1				1 PC
2	Glass			1 PC

ASSEMBLY INSTRUCTIONS

Step 1

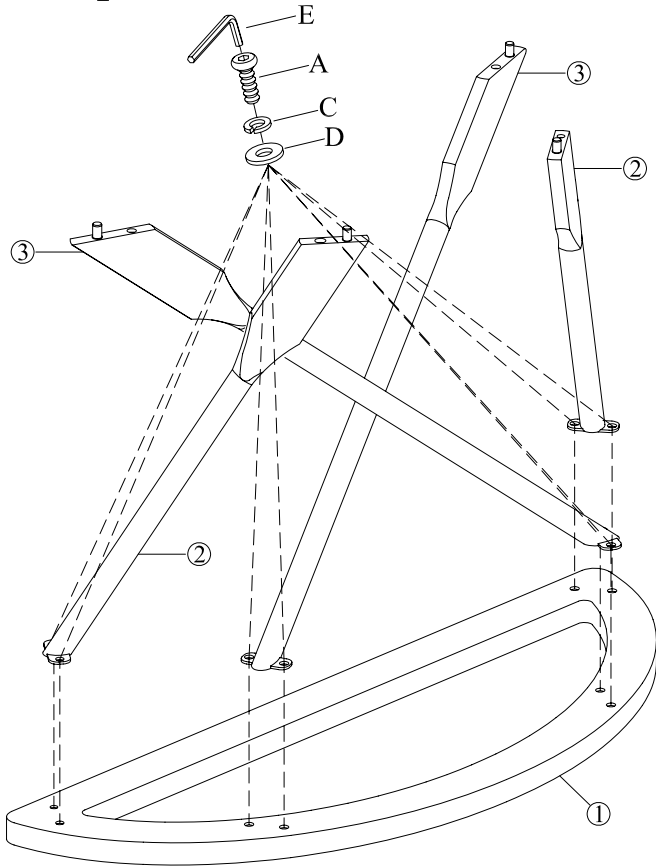

Step 2

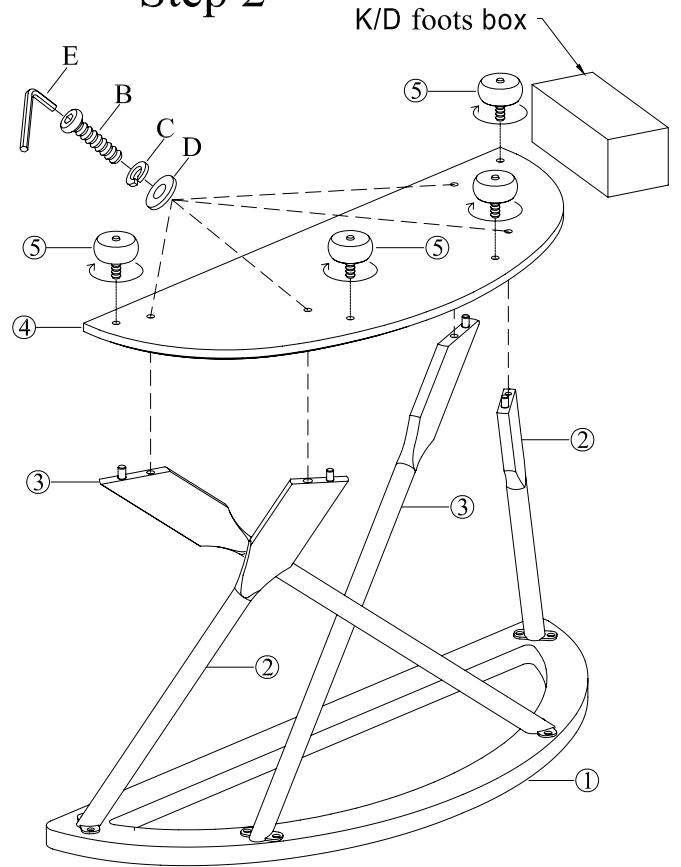

Step 3

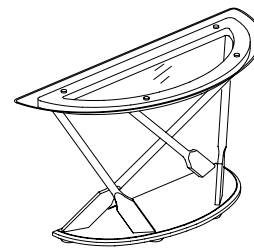
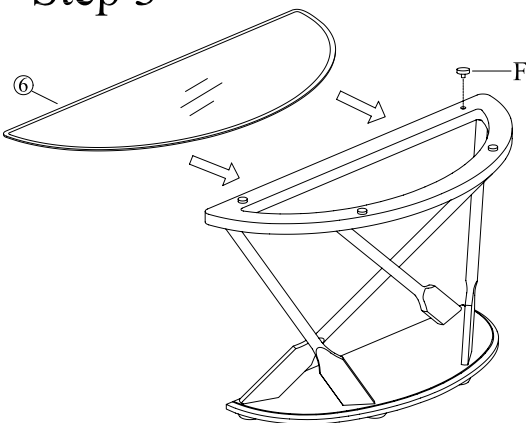

LIST OF PARTS AND ARDWARE:

No.	Description	Q'ty
A	Bolt Ø1/4"*5/8"	8 PCS
B	Bolt Ø1/4"*1-3/4"	4 PCS
C	Lock Washer Ø1/4"	12 PCS
D	Flat Washer Ø1/4" *16	12 PCS
E	Allen Wrench 4mm	1 PC
F	Glass Bumper	4 PCS

LIST OF PARTS AND ARDWARE:

No.	Description	Q'ty
1	Top	1 PC
2	Front Leg	2 PCS
3	Back Leg	2 PCS
4	Shelf	1 PC
5	Foot	4 PCS
6	Glass	1 PC