

Assembly Instruction

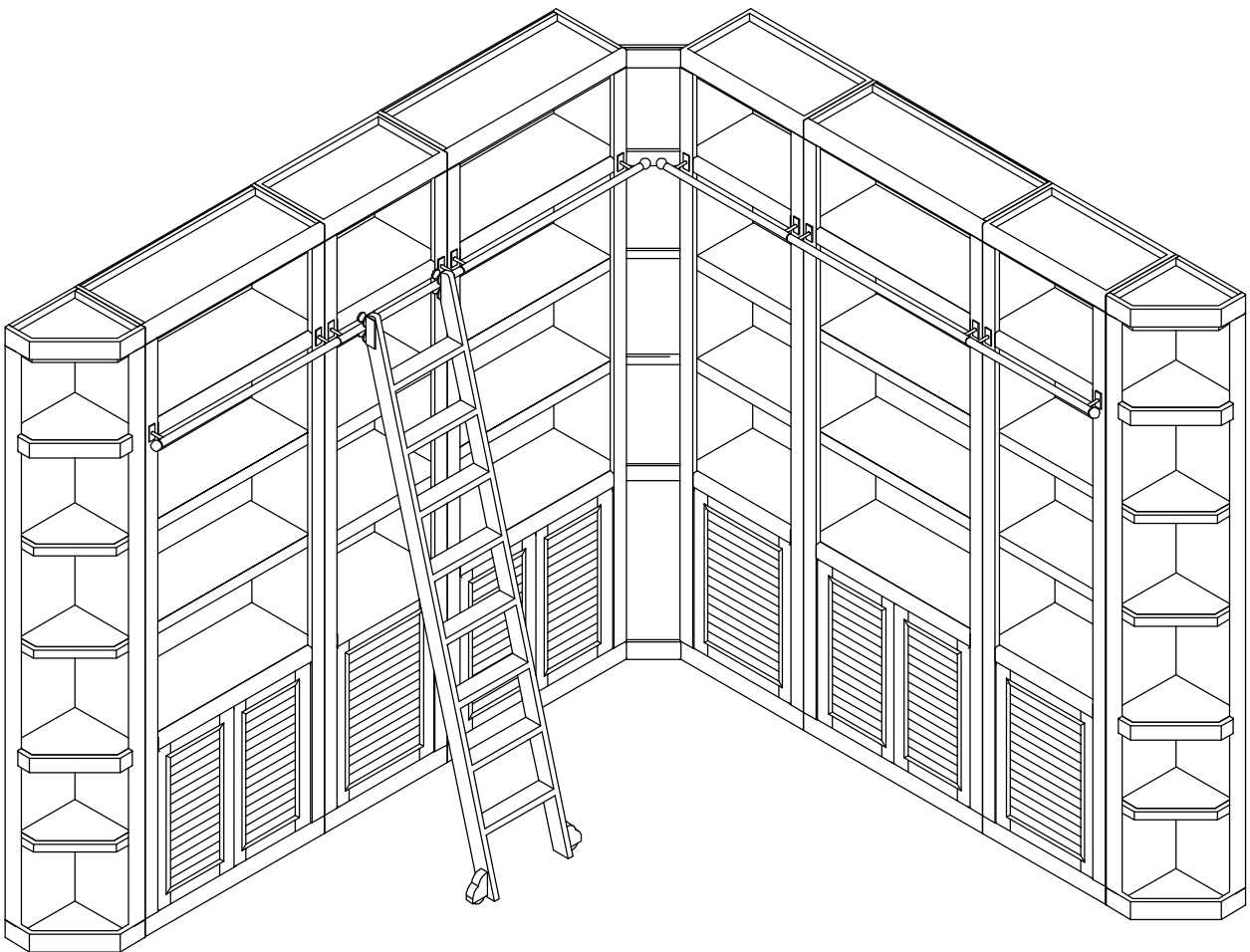

Item No: LIBRARY



Assembly Instruction

Description : OUTSIDE CORNER

HARDWARE LIST

No	Description	Sketch	Q'TY
A	Allen wrench 4mm		1PC
B	Bolt Ø 1/4"x1"		6PCS
C	Screw cap Ø 1/4" x5/8"		6PCS

STEP 1

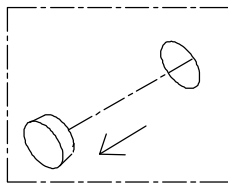

Push out

BOC#450

Hardware pack is here

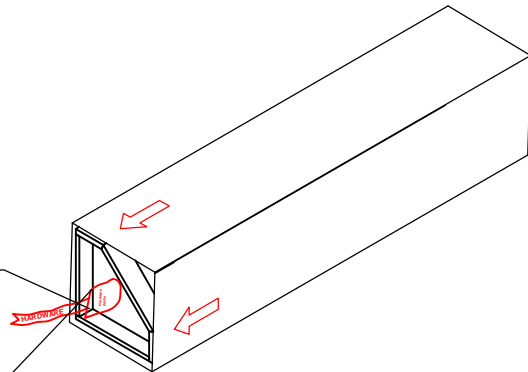

BOC#420

STEP 2

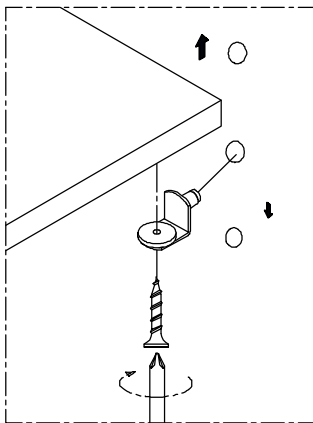
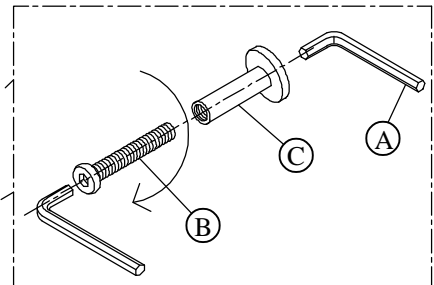

To adjust the shelf height, remove the four screws under each shelf pin. once removed, place shelf pins at desired height and re-screw shelf pins.

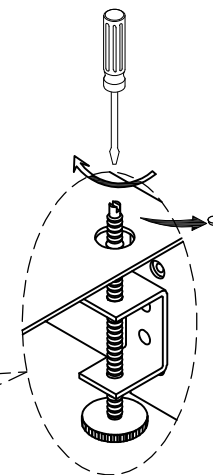
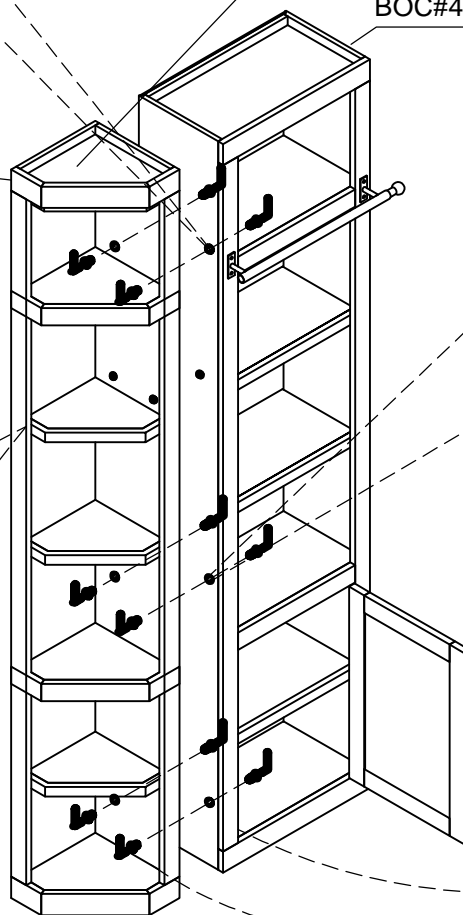

To adjust and access levelers, first remove plastic cap if it have with a flat-head screwdriver. Using the same screwdriver, proceed to turn leveler clockwise to raise the piece, or counterclockwise to lower the piece.