

PRODUCT MANUAL

LP GAS GRILL

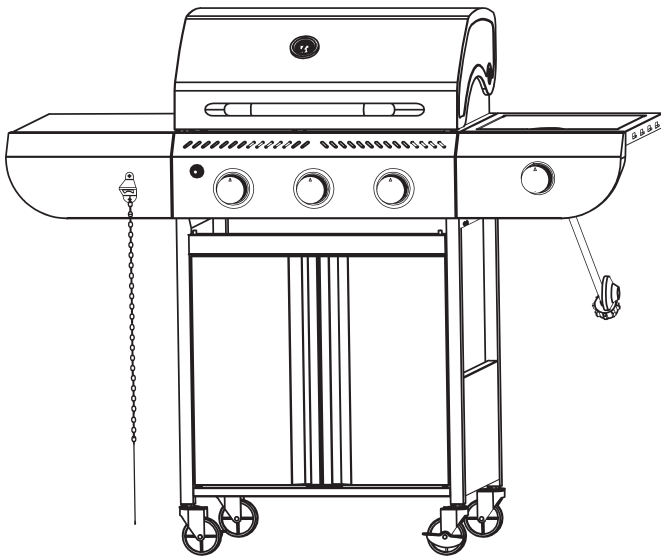

Model No.: JD-3B
Item No.: 00031GBA0-EL

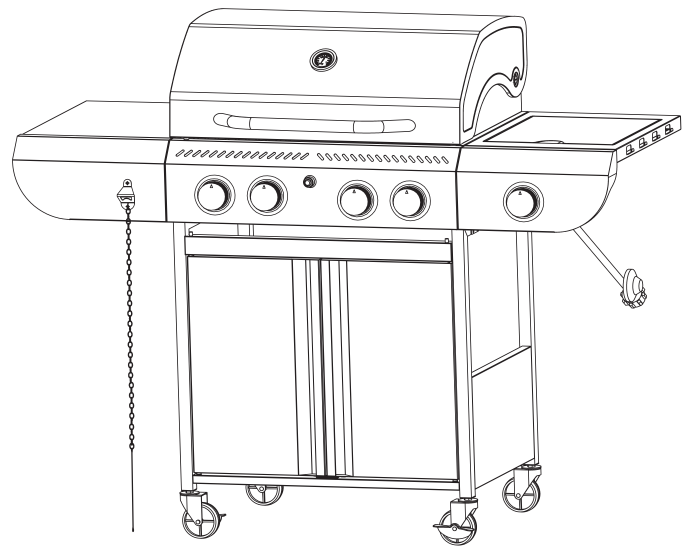

Model No.: JD-4B
Item No.: G0141B-EL

NOTE: The pictures are for reference only, the actual product shall prevail.



Scan the QR code to watch
the product videos

 **Web:** www.electacticshop.com

 **Email:** service@electacticshop.com

 **Tel:** 888-698-2504

TABLE OF CONTENTS

Safety Information	1
Package Contents	3
Assembly Instructions	4
Operation Instructions	20
Care and Maintenance	25
Troubleshooting	28

Assembler/Installer: This manual contains important information that is necessary for the proper assembly and safe use of this appliance. Read and follow all warnings and instructions before assembling and using this appliance. **Leave these instructions with the consumer.**

Consumer/User: Follow all warnings and instructions when using this appliance.
Retain these instructions for future reference.

DANGER

If you smell gas:

1. Cut off the gas to the appliance.
2. Extinguish any open flame.
3. Open the lid.
4. If the odor continues, keep away from the appliance and immediately call your local fire department.

WARNING

1. Do not store or use gasoline, vapors, or other flammable fluids close to this or any other appliance.
2. An LP cylinder not connected for use shall not be stored in the vicinity of this or any other appliance.
3. This grill is only for outdoor use and shall not be used in a building, garage, under overhangs or any other enclosed area.
4. Do not leave a lit grill unattended. Keep children and pets away from the grill at all times.



SAFETY INFORMATION

DANGER

- Do not use in an explosive atmosphere. Keep grill area clear and free from combustible materials, gasoline and other flammable vapors and liquids.

CALIFORNIA PROPOSITION 65

Fuels used in gas or oil fired appliances and the products of combustion of such fuels contain chemicals, including Benzene, known to the State of California to cause cancer, birth defects or other reproductive harm. This product contains chemicals, including lead and lead compounds, known to the State of California to cause cancer, birth defects or other reproductive harm. ***Wash hands after handling.***

CAUTION

- Never use charcoal or lighter fluid with the grill.
- Do not use gasoline, kerosene or alcohol for lighting.
- The LP gas cylinder used with this appliance must be:
 - (a) Constructed and marked in accordance with the Specifications for LP-Gas Cylinders of the U.S. Department of Transportation (D.O.T.) or the National Standard of Canada, CAN/CSA-B339, Cylinders, Spheres and Tubes for Transportation of Dangerous Goods; and Commission, as applicable; and
 - (b) Provided with a listed overfilling prevention device.
 - (c) Provided with a cylinder connection device compatible with the connector for outdoor cooking appliances. This grill is not intended to be used in or installed on recreational vehicles and/or boats.
 - (d) The marked cylinder water capacity or LPG capacity (in pounds) as stated by the cylinder manufacturer(s).
- Never keep a filled container in a hot car or car trunk. Heat will cause the gas pressure to increase, may open the relief valve and leak the gas.
- Always open grill lid slowly and carefully as heat and steam trapped within the grill can hurt you severely.



SAFETY INFORMATION

⚠ WARNING

Do not place the grill under overhead combustible construction or awnings.
The minimum clearance between the side/back of the unit and any other construction is 40 inches (1016.0 mm).

NOTE: The installation must conform with local codes or, in the absence of local codes, with either the National Fuel Gas Code, ANSI Z223.1/ NFPA54, Natural Gas and Propane Installation Code, CSAB149.1, or Propane Storage and Handling Code, B149.2.

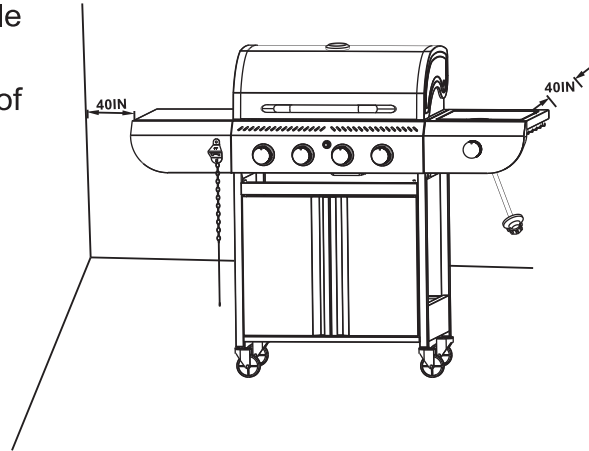

⚠ CAUTION

- Do not store or use gasoline or other flammable liquids or vapors close to this or any other appliance.
- An LP cylinder not connected for use shall not be stored close to this or any other appliance.
- This grill is for using with propane gas only (propane cylinder not included).
- Never attempt to attach this grill to the self-contained propane system of a boat, camper trailer, motor home or house.
- Do not attempt to move the grill while it is lit or when it is hot. The casters should be locked down when not moving the grill.
- Do not use the grill unless it is completely assembled and all parts are securely fastened and tightened.
- Keep all combustible items and surfaces at least 40 inches (101.6 cm) away from the grill at all times.
- Do not touch metal parts of grill until it has completely cooled (about 45 minutes) to avoid burns, unless you are wearing protective gear (pot holders, gloves, BBQ mittens, etc.).
- Do not alter this grill in any manner.
- Clean and inspect the hose before each use. If there is obvious abrasion, wear, cuts, or leaks, the hose must be replaced prior to operating the appliance. The replacement hose assembly shall be that specified by the manufacturer.
- Move gas hoses as far away as possible from the hot surfaces and dripping hot grease.
- Keep the grill's valve compartment, burners and circulating air passages clean. Inspect the grill before each use. Do not obstruct the flow of gas or ventilation air.
- The use of alcohol, prescription or non-prescription drugs may influence the operator's ability to properly assemble or safely operate the grill.
- **Do not leave a lit grill unattended. Keep children and pets away from the grill at all times.**
- Do not place this grill on any type of tabletop surface. The grill should be placed on a flat and level surface.
- Do not use the grill in strong winds.

PACKAGE CONTENTS

NOTE: Please read the picture and product list of the package contents carefully before assembly. Scan the QR code on the cover to watch the installation video.

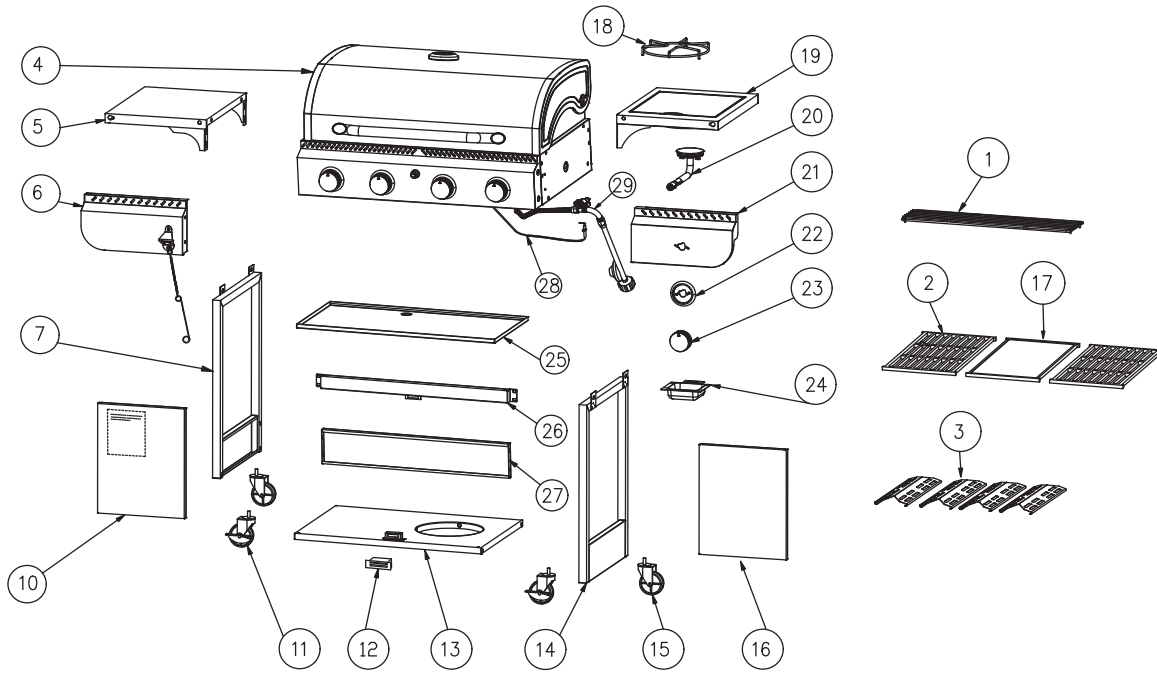

Part Number	Description	Quantity	Part Number	Description	Quantity
1	Warming rack	1	16	Right door	1
2	Cooking grate	2	17	Cooking Plate	1
3	Grill heat plate	The actual parts may differ depending on the different model.	18	Burner rack	1
			19	Right burner table	1
4	Grill body assembly	1	20	Side burner	1
5	Left side table	1	21	Right front panel	1
6	Left front panel	1	22	Knob base	1
7	Left frame	1	23	Knob	1
10	Left door	1	24	Oil drip box	1
11	Caster with brake	2	25	Oil drip tray	1
12	Magnet	1	26	Beam	1
13	Bottom panel	1	27	Back panel	1
14	Right frame	1	28	Igniter	1
15	Caster without brake	2	29	Gas hose assembly	1

NOTE: Parts 25, 28, 29 are preinstalled on the part 4.

NOTE: The actual parts may differ depending on the different model. The model JD-3B contains 3 grill heat plates, while the model JD-4B contains 4 grill heat plates.

Picture	Part No.	Part Description	Quantity
	AA	M6x12mm	38 (2 for spare parts)
	CC	Door Axis	2
	DD	Door Post	2
	EE	M4x10mm	3
	HH	Wrench	1

ASSEMBLY INSTRUCTIONS

Before start assembling product, make sure all parts are present. Compare parts and hardwares with the list on the package contents page. If any part is missing or damaged, do not attempt to assemble the product. Contact customer service for replacement parts.

Estimated Assembly Time: 50 minutes with 2 people.

Tools Required for Assembly and Leak Testing: Phillips screwdriver, Spray bottle, Pliers, Adjustable Wrench

NOTE: Common tools used for assembly and leak testing are not included in the accessories.



⚠ CAUTION

THIS UNIT IS HEAVY. Two people are required for safe assembly.

Two people are required for safe assembly. Some parts may contain sharp edges. Wear protective gloves if necessary. Read and follow all safety statements, warnings, assembly instructions and use and care instructions before attempting to assemble and use.

ASSEMBLY INSTRUCTIONS (Take JD-4B for an example)

A. Installation of Magnet

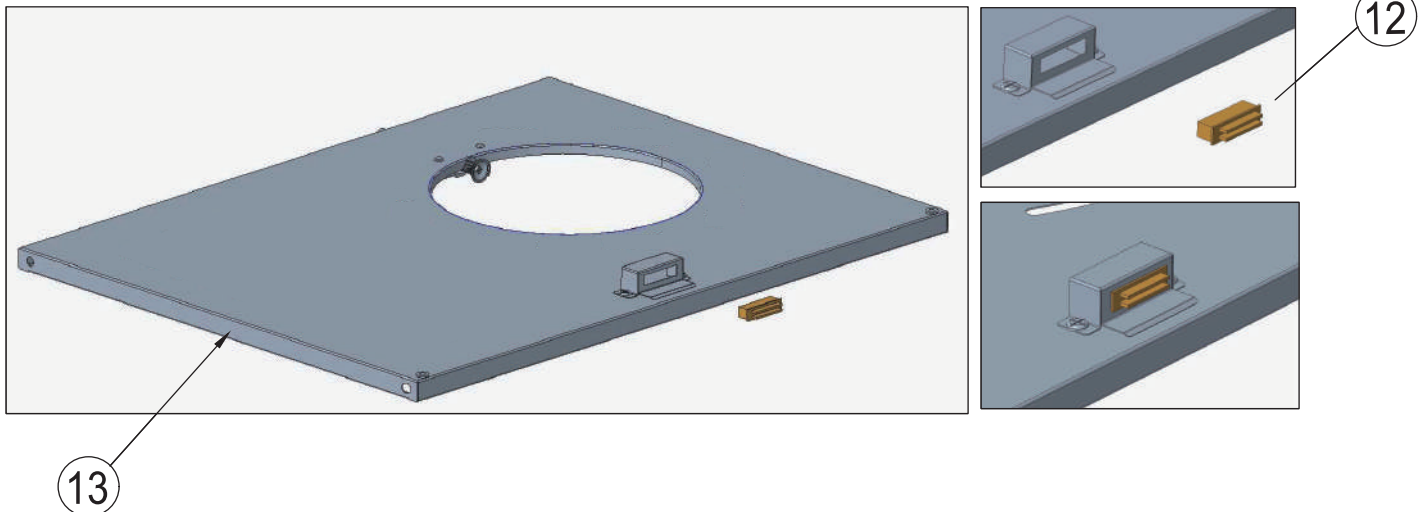

Place the bottom panel (13) in the direction as shown in the figure (front side forward), insert the magnet(12) into the base.

Note: Ensure that the adsorption surface of the magnet faces forward to adsorb and fix the two doors which will be installed later.

ASSEMBLY INSTRUCTIONS

B. Installation of Left/Right Frame

Note: There is a L/R sticker on the left/right frame(ensure that the right frame is assembled on the side near the nesting hole of the bottom panel).

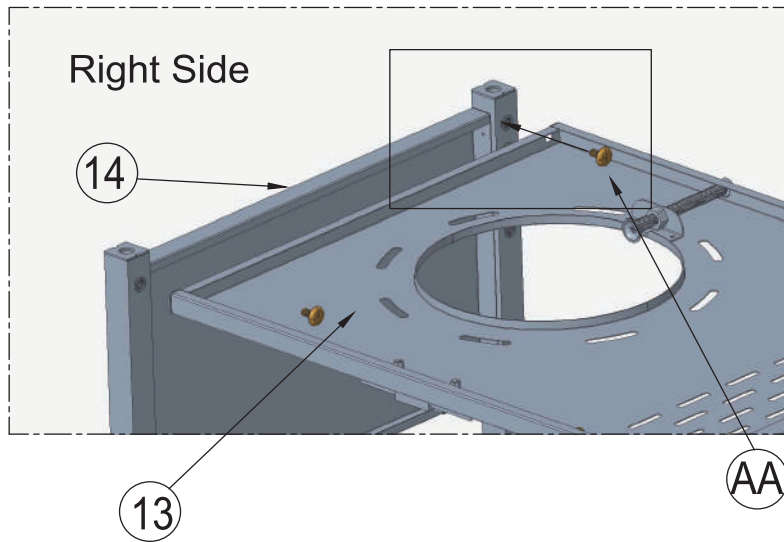
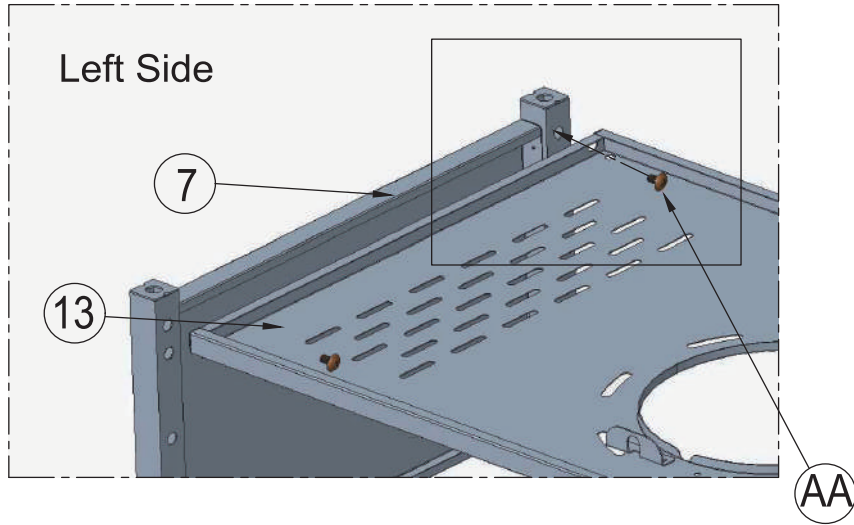

Place the left frame (7) (with sticker L affixed) and right frame (14) (with sticker R affixed) in the direction shown in pictures above. Align the holes on the side of the two frames and the holes on the side of the bottom panel, assemble the frames and the bottom panel together with 4 AA screws.

ASSEMBLY INSTRUCTIONS

C.Installation of Back Panel

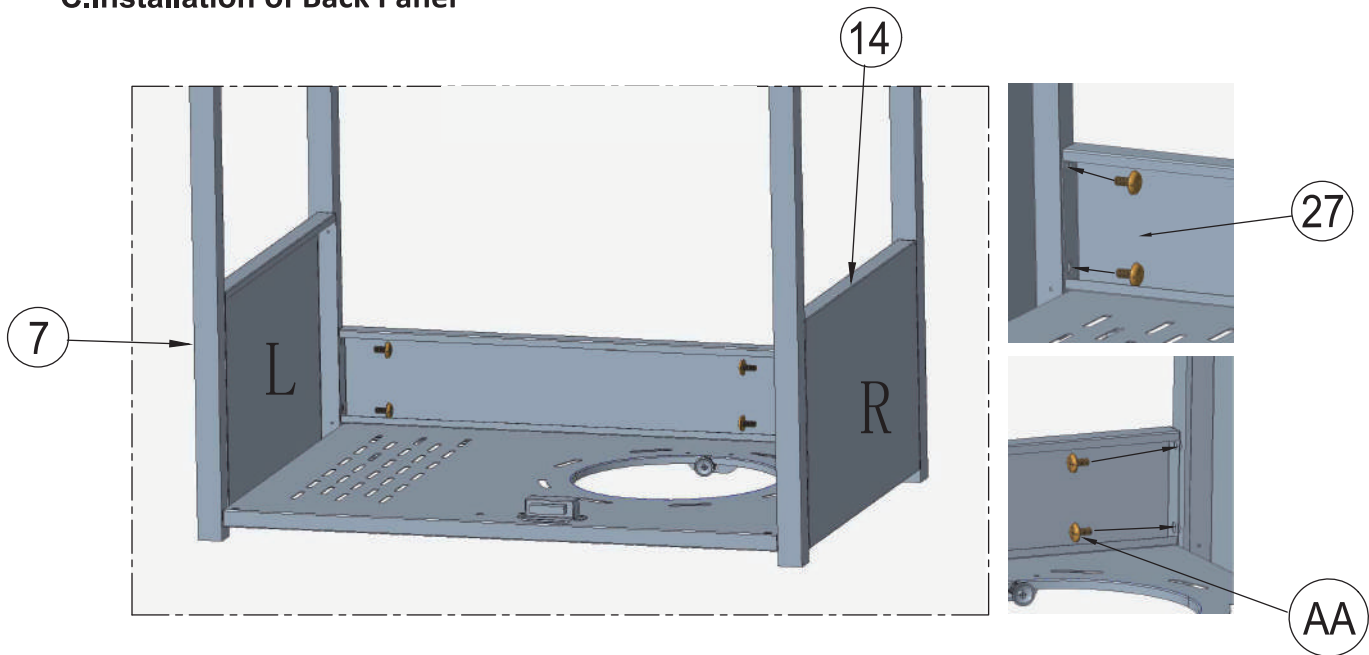

Install the back panel (27) between the left and right frames with 4 AA screws

D.Installation of Casters with (without) Brake

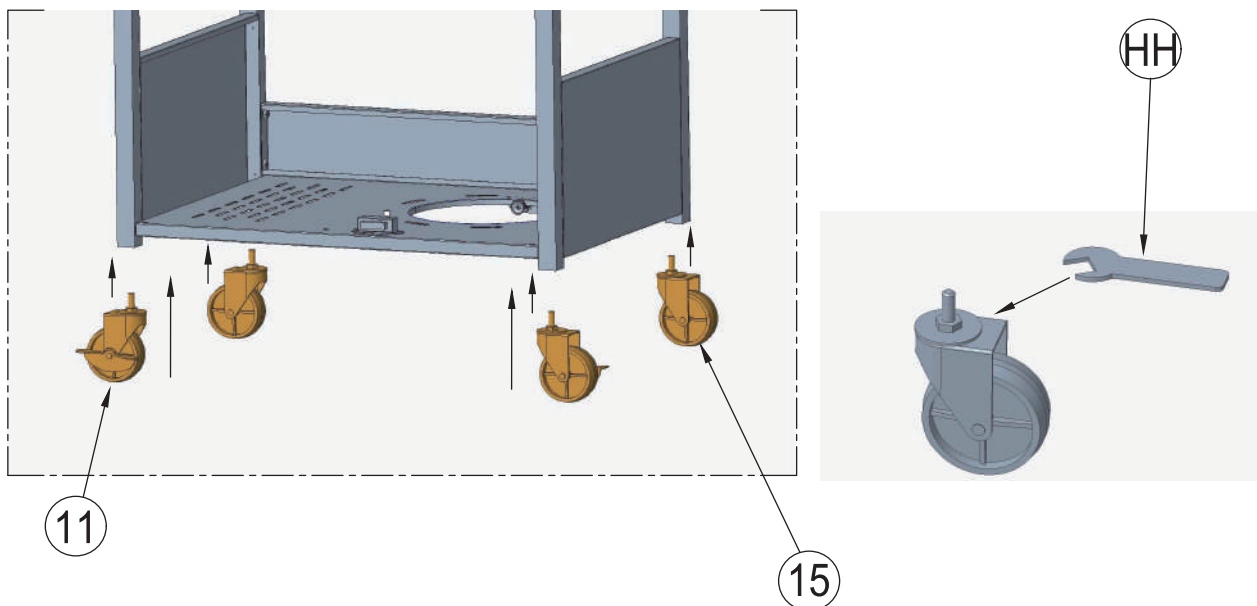

Install the casters with brake (11) and the casters without brake (15) under the bottom of the bottom panel and adjust the height of the casters with the HH wrench.

NOTE: The casters can be locked and loosened by turning the brake.

NOTE: For easy movement, be sure to install the same type of casters on the same side of the bottom panel. It's suggested to install the casters with brake near the front side.

ASSEMBLY INSTRUCTIONS

E. Installation of Beam

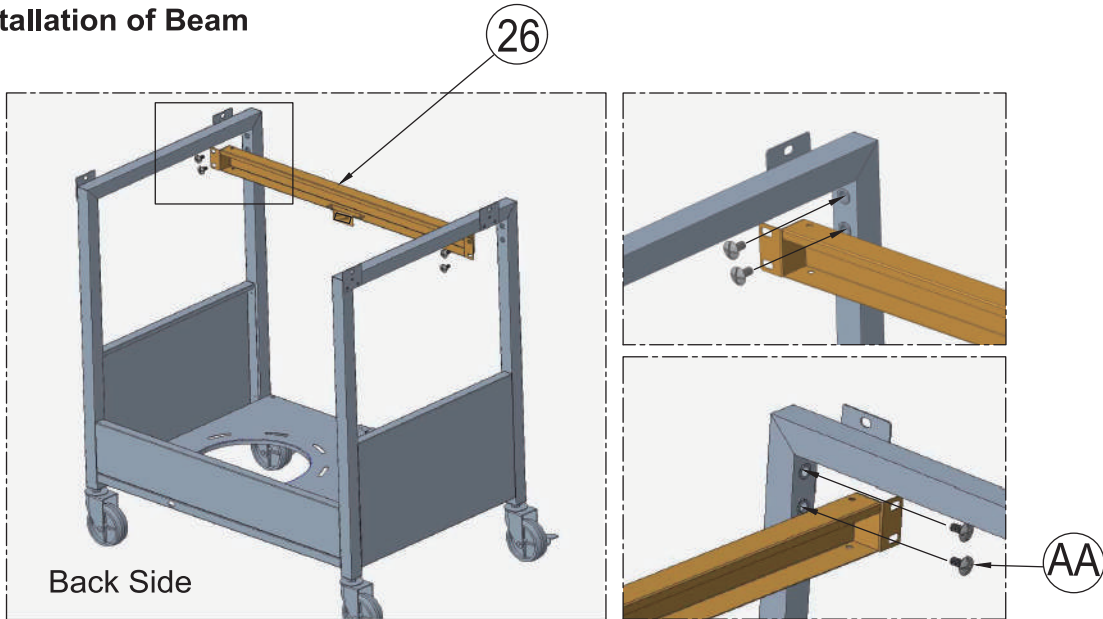

Place the unit in the direction shown in Picture (back side forward), and install the beam (26) between the two frames with 4 AA screws.

Note: Ensure that the adsorption surface of the magnet faces forward the front side to adsorb and fix the two doors which will be installed later.

F. Pre-installation of CC and DD Screws

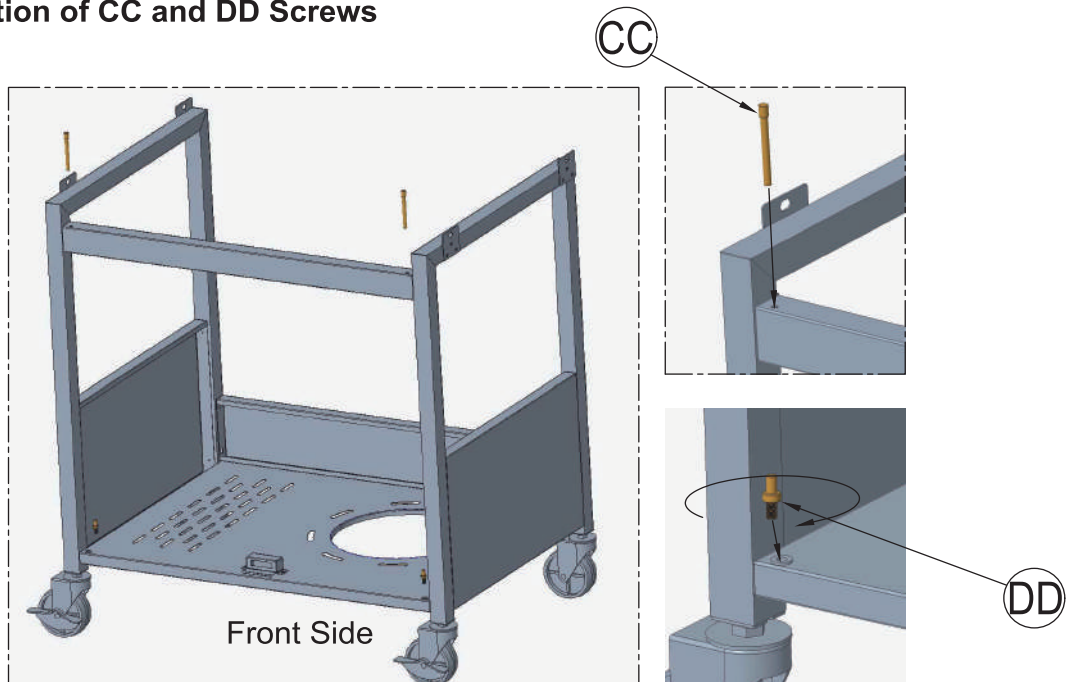

Place the unit in the direction shown in Picture (front side forward). Put 2 CC screws in the corresponding positions on the beam, and put 2 DD screws in the corresponding positions on the bottom panel and tighten the DD screws for use when installing doors later.

ASSEMBLY INSTRUCTIONS

G.Installation of Left/Right Door

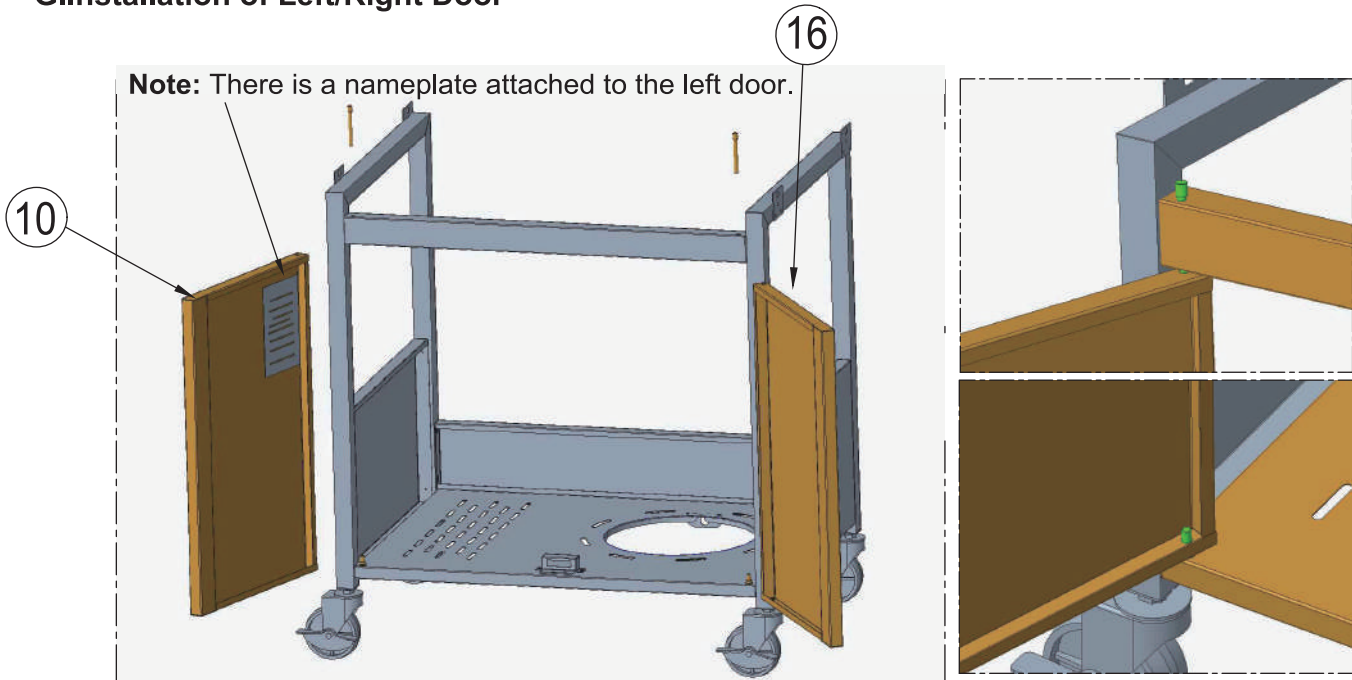

Insert the previously fixed DD screws into the holes at the bottom of the left door (10) and the right door (16), and then adjust the CC screws into the holes at the top of the doors. You can adjust the height of the casters with the HH wrench if the two doors don't line up.

H.Remove the Protective Accessories from the Grill Body

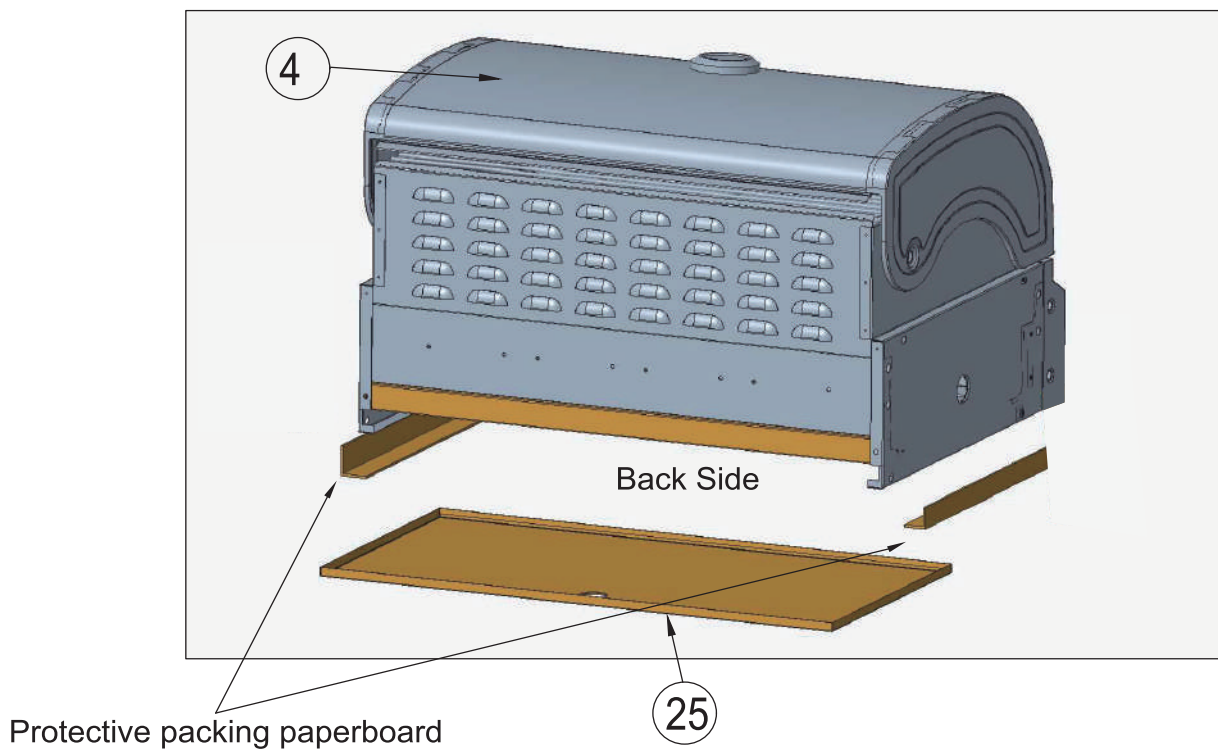

Take out the oil drip tray, remove the protective packing paperboard on both sides of it, and then put the oil drip tray back.

ASSEMBLY INSTRUCTIONS

I. Installation of Grill Body Assembly

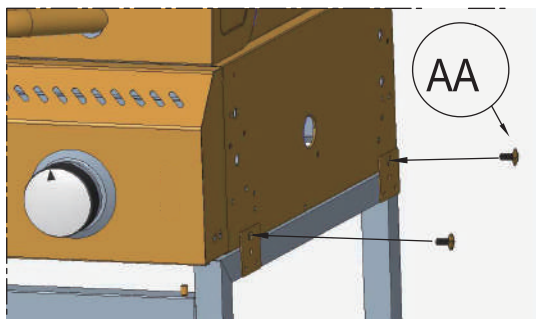

NOTE: Please note that both sides of the grill body must be screwed with AA screws.

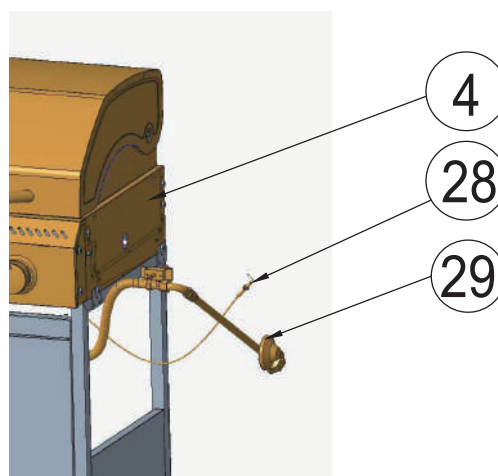

Install the grill body on the two frames with 4 AA screws.

Note: Before installing the grill body, it is necessary to pass the igniter (28) and the gas hose assembly (29) through the right frame.

ASSEMBLY INSTRUCTIONS

J. Pre-installation of Screws on the Grill Body

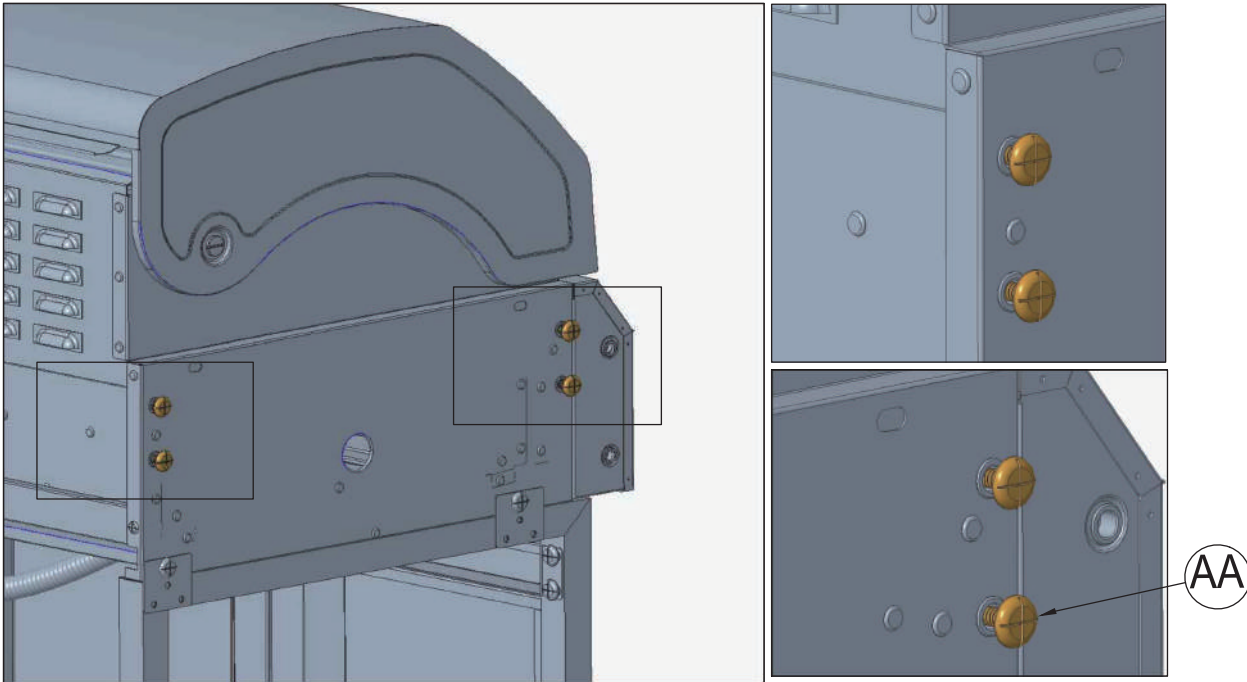

Preattach 8 AA screws respectively to the left and right sides of the grill body.

Note: Do not tighten the screws for following installation of the left side table and the right burner table.

K. Installation of Left Side Table and Left Front Panel

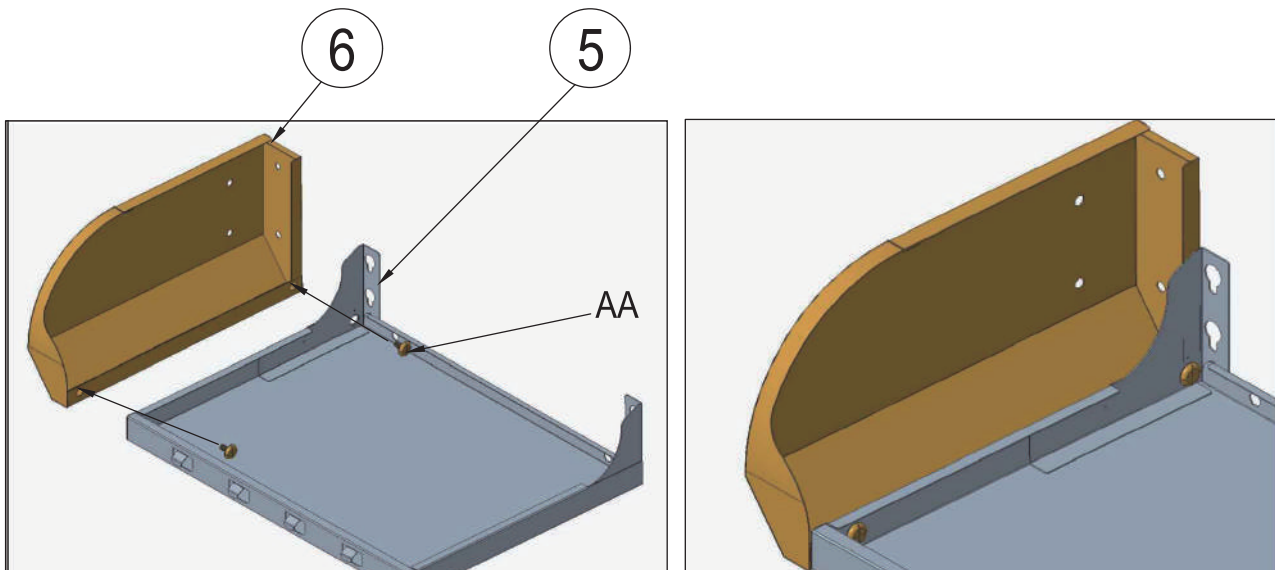

Pre-attach 2 AA screws to the left side table (5) (do not tighten), then assemble the left side table (5) and left front panel (6) together and tighten the screws.

ASSEMBLY INSTRUCTIONS

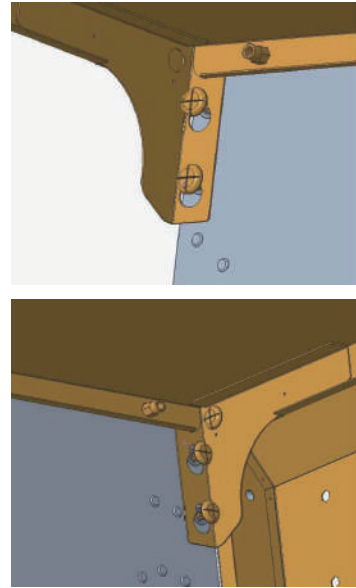
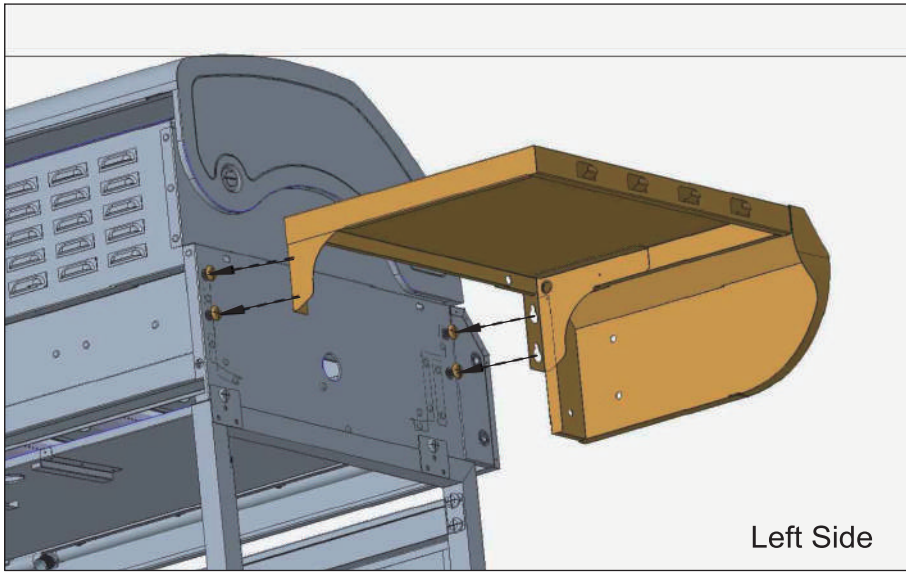

Align the left side table with the 4 pre-attached AA screws on the left side of the grill body and then tighten them.

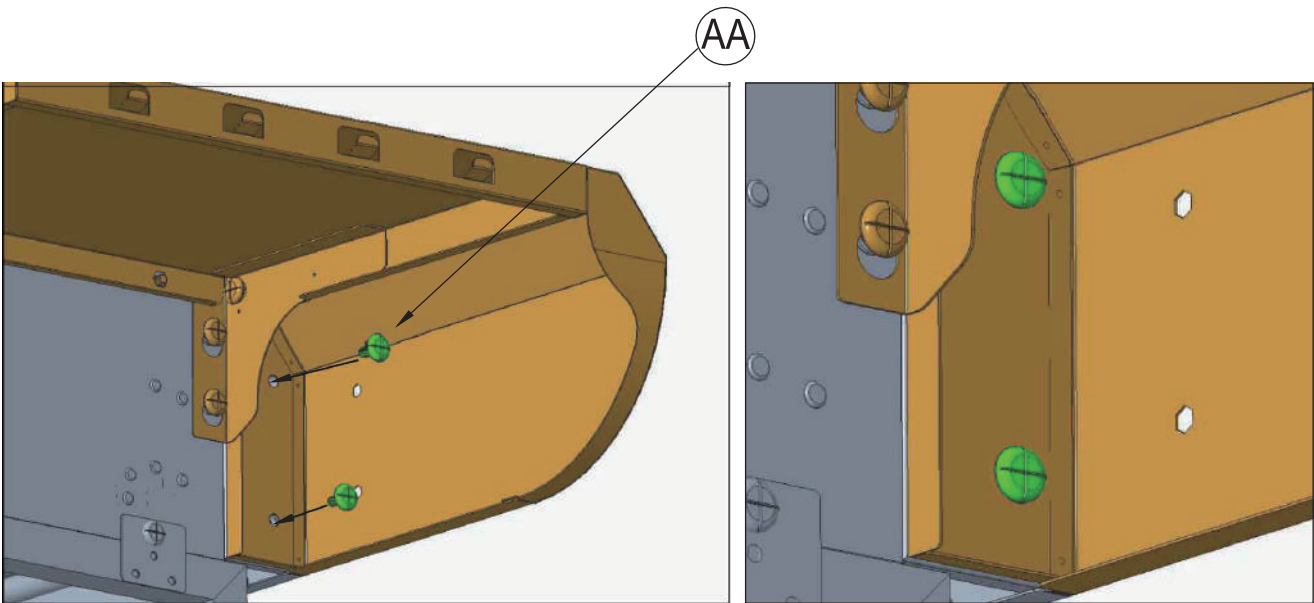

Fix the left front panel to the left side of the grill body with 2 AA screws.

ASSEMBLY INSTRUCTIONS

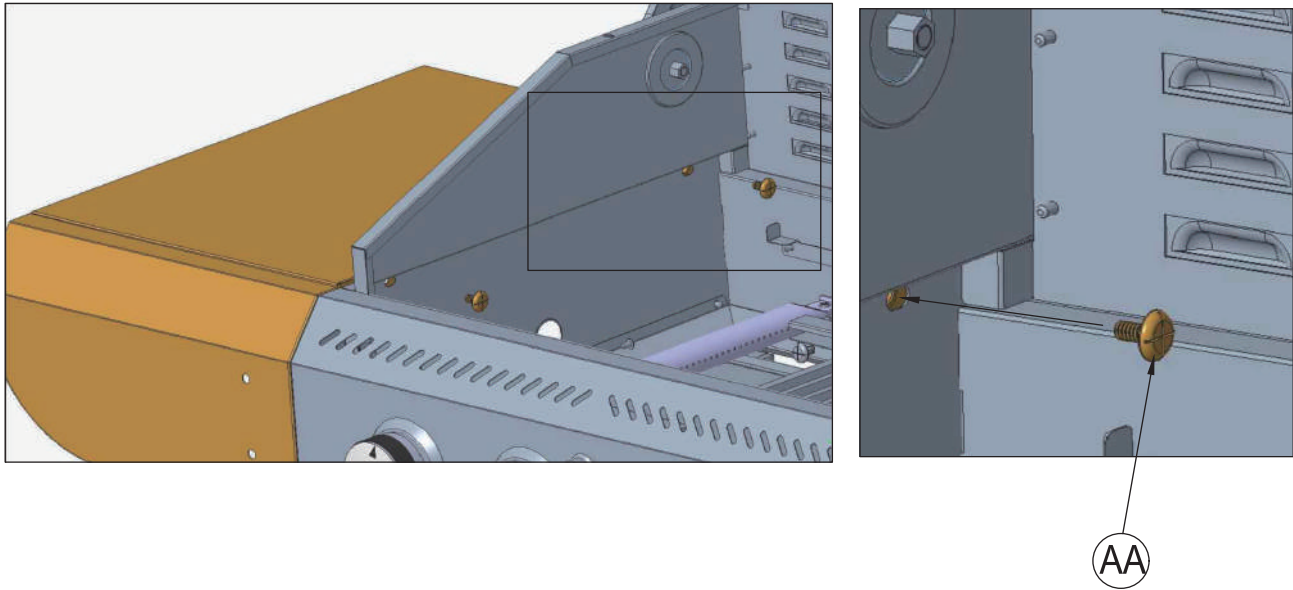

Fix the left side table to the left side of the grill body with 2 AA screws screwing from inside the grill body. After adjustment, tighten the 4 pre-attached AA screws on the left side of the grill body to completely fix the left side table and the left front panel together with the grill body.

L.Installation of Right Burner Table and Right Front Panel

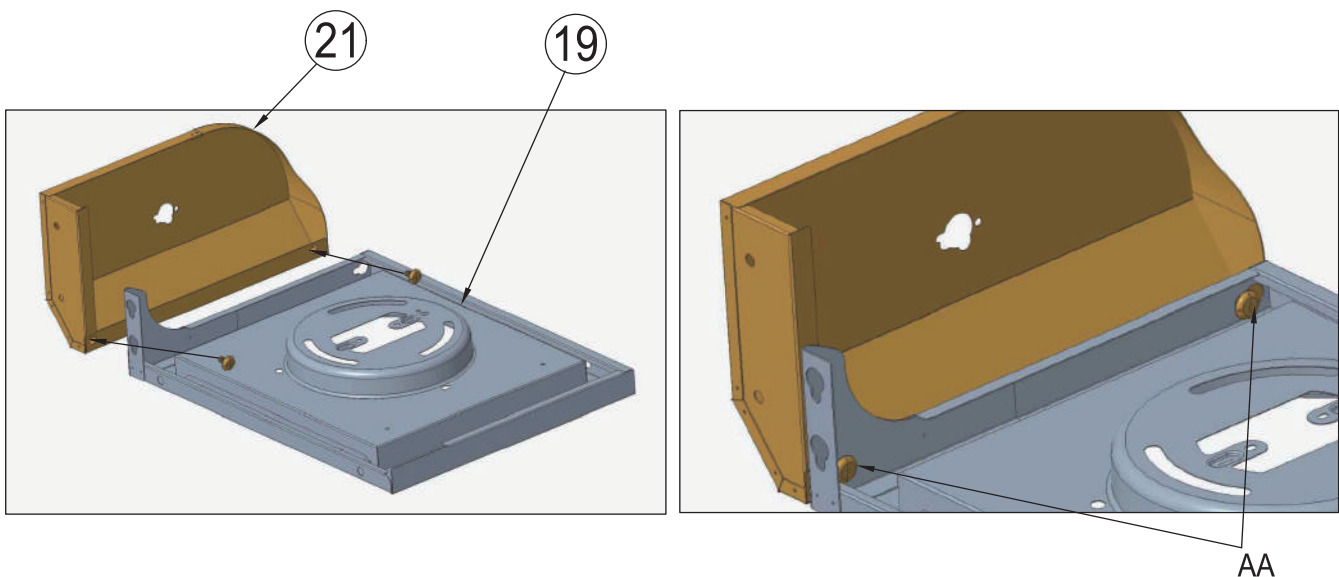

Preattach 2 AA screws to the right burner table (19) (do not tighten), then assemble the right burner table (19) and the right front panel (21) together and tighten the screws.

ASSEMBLY INSTRUCTIONS

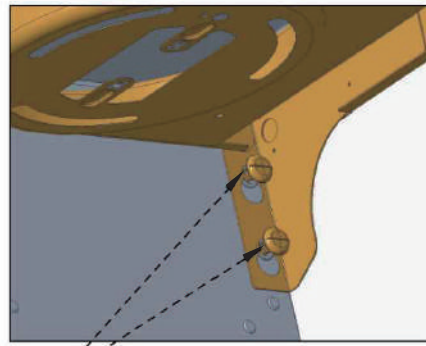
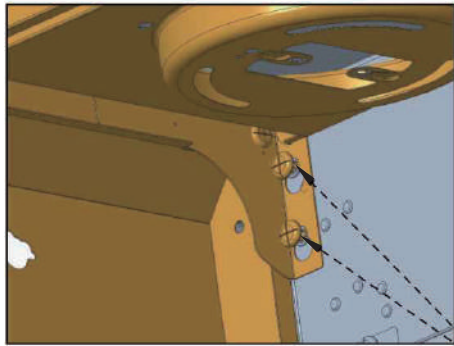

Tighten the screws

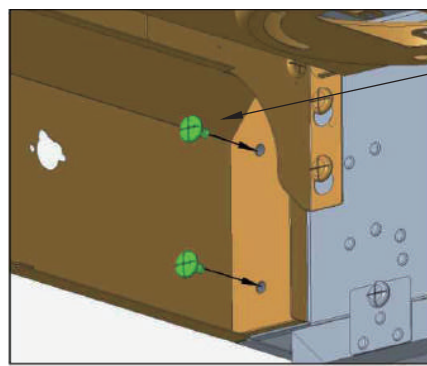
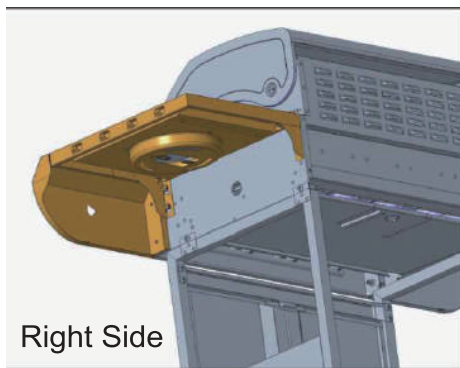

Align the right burner table with the 4 pre-attached AA screws on the right side of the grill body and then tighten them.

Fix the right front panel to the right side of the grill body with 2 AA screws.

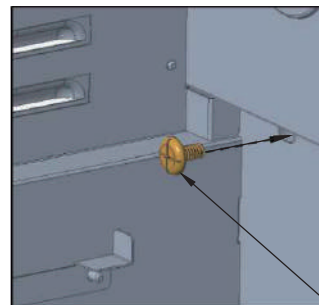
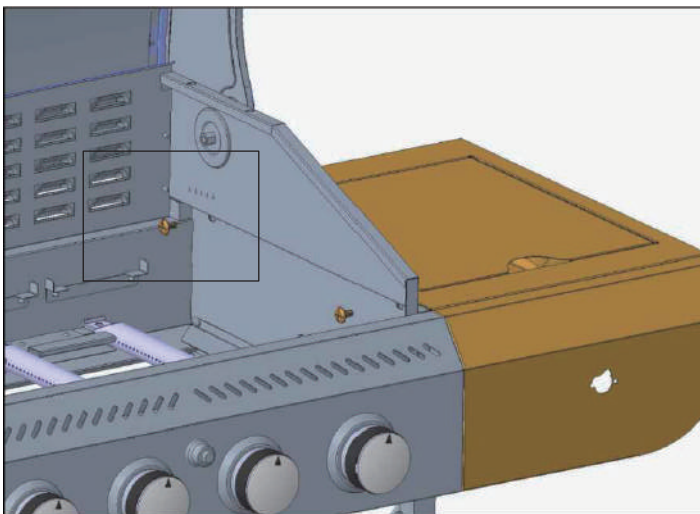

Fix the right burner table to the right side of the grill body with 2 AA screws screwing from inside the grill body.

After adjustment, tighten the 4 pre-attached AA screws on the right side of the grill body to completely fix the right burner table and the right front panel together with the grill body.

ASSEMBLY INSTRUCTIONS

M. Installation of Knob and Valve

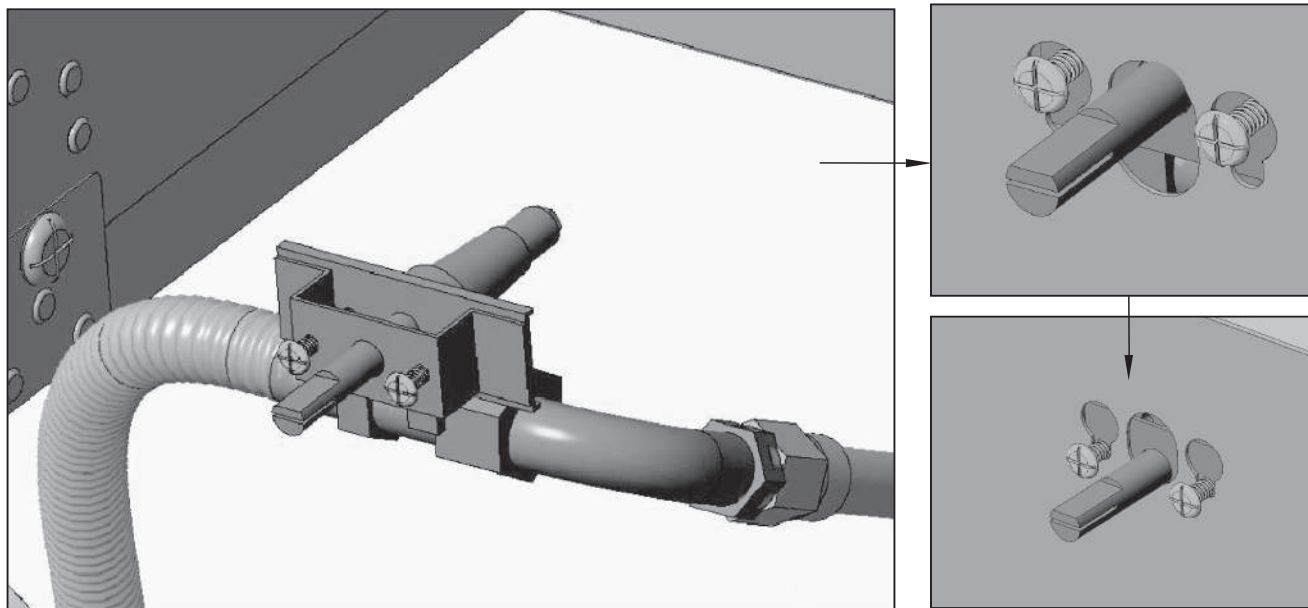

Put the screws on the valve through the holes in the right front panel and press them downward for solidity.

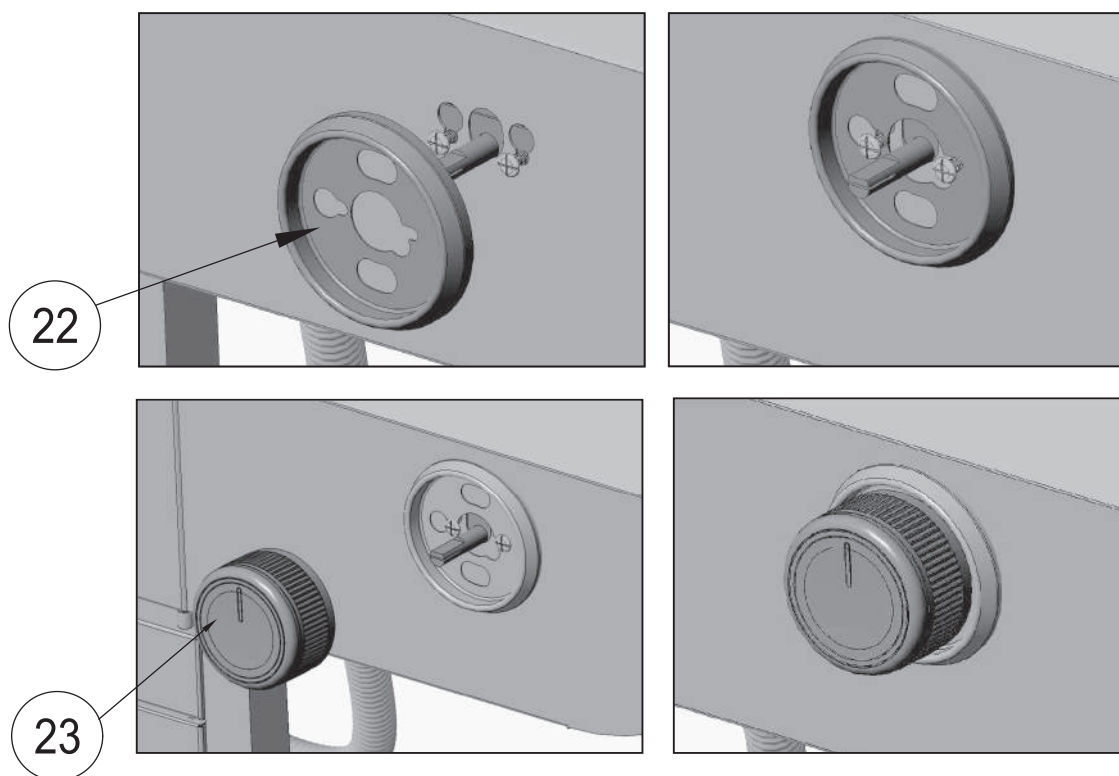

Pass the screws through the holes in the knob base (22) as show and tighten the screws to secure the base.

Pass the hole in the back of the knob(23) through the valve and adjust to install the knob.

ASSEMBLY INSTRUCTIONS

N. Installation of Side Burner

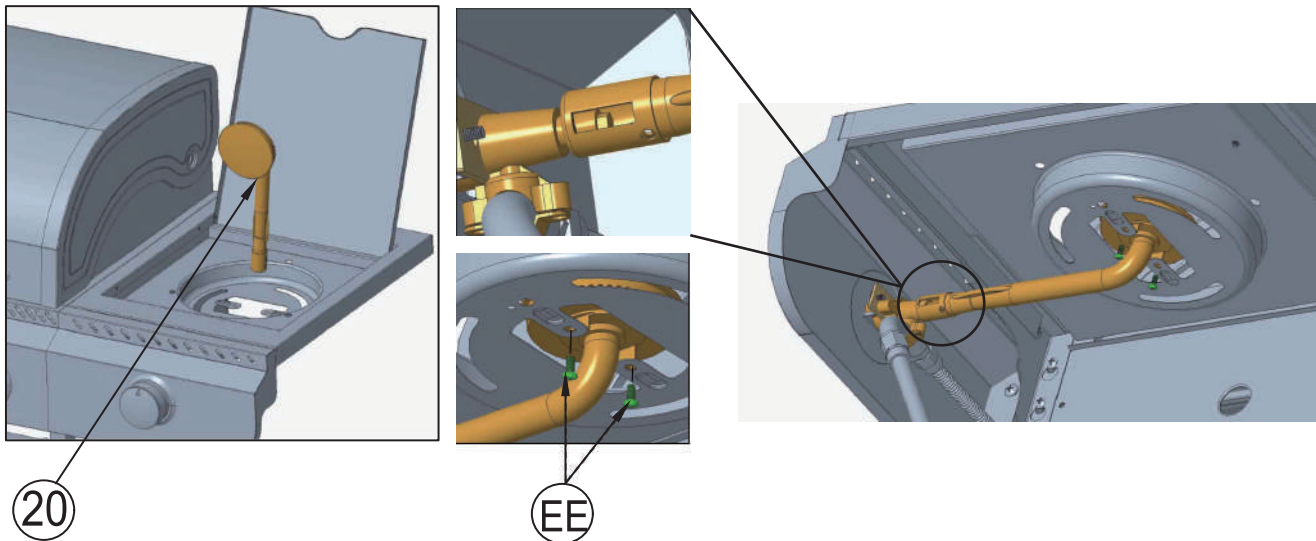

Insert the side burner (20) into the middle of the right burner table from the top down, put the tail of the side burner over the valve, then fix the side burner to the right burner table with 2 EE screws from below.

O. Installation of Igniter

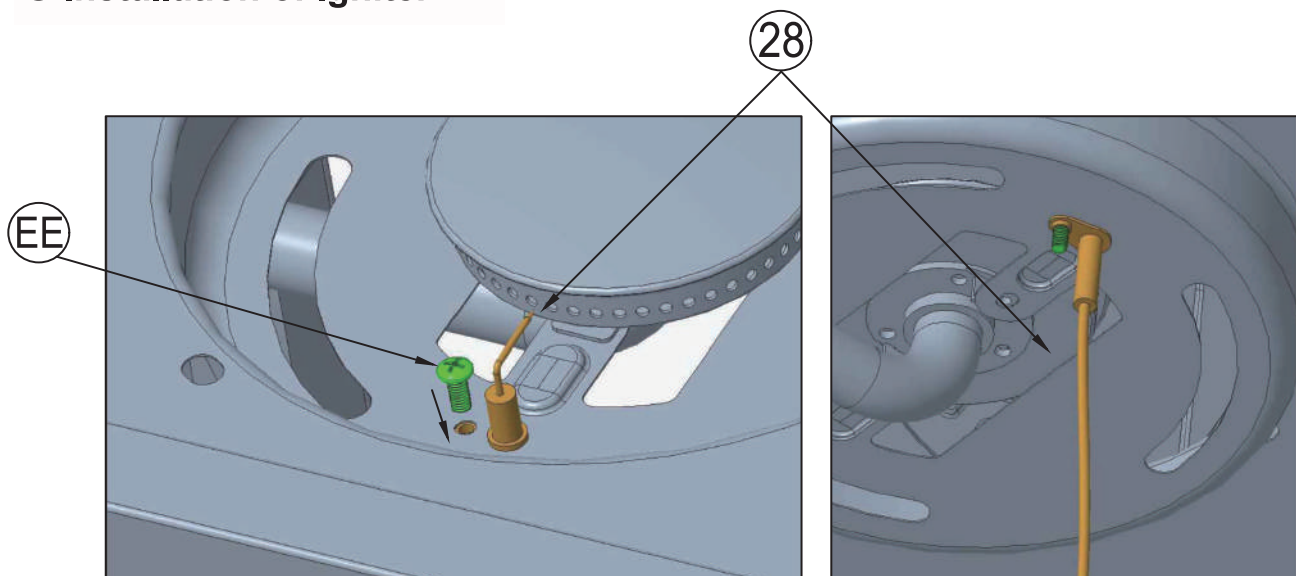

Place the igniter through the round hole on the right burner table (as shown in the picture) from the bottom up, adjust the direction and place a EE screw through the other round hole to fix the igniter to the right burner table.

ASSEMBLY INSTRUCTIONS

P. Installation of Warming Rack and Burner Rack

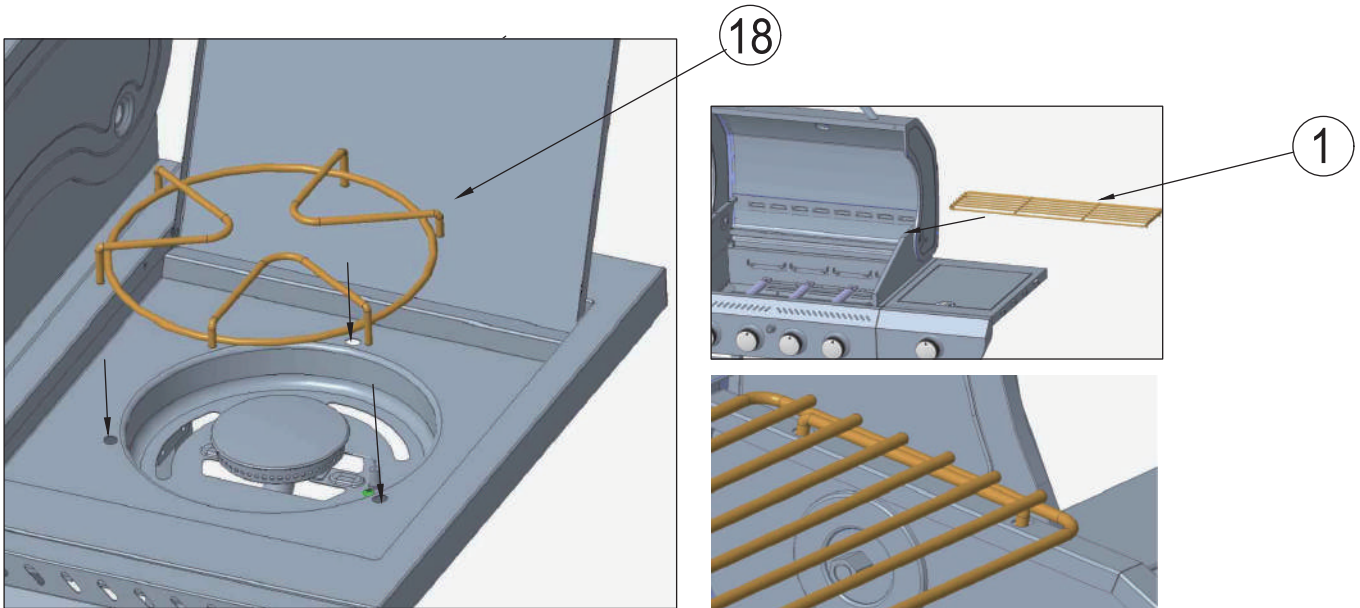

Insert the burner rack (18) into the specified holes on the right burner table. Then insert the warming rack (1) into the specified holes on both sides of the grill body.

Q. Installation of Grill Heat Plate

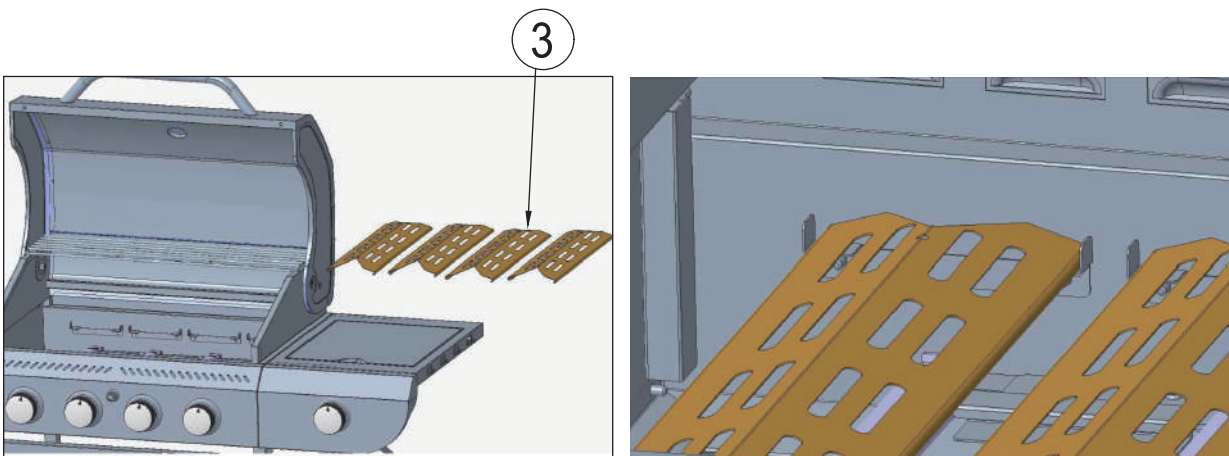

Install the grill heat plate (3) in place, noting that each grill heat plate must be placed in the specified slot.

Note: The actual parts may differ depending on the different models.

ASSEMBLY INSTRUCTIONS

R. Installation of Cooking Grate And Plate

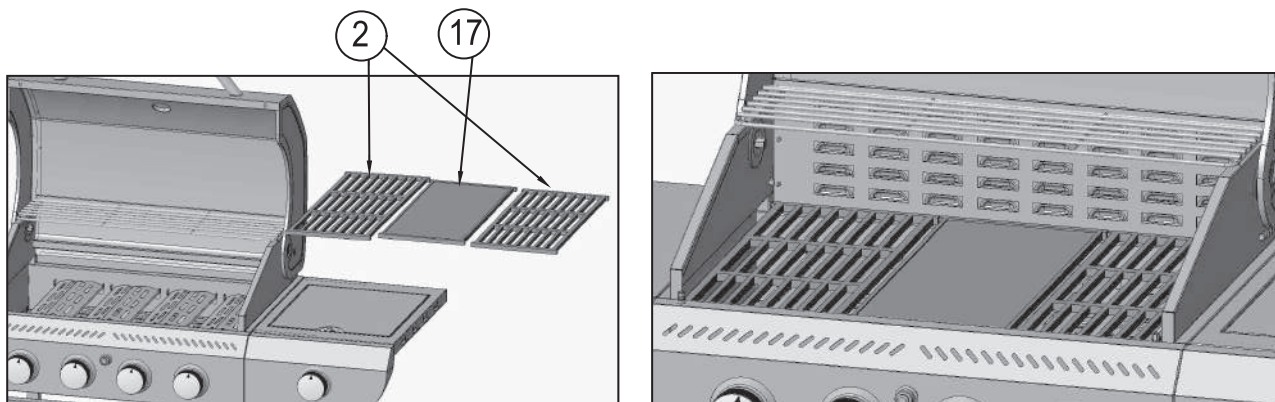

Place the two pieces of cooking grates(2) and one piece of cooking plate(17) .

S. Installation of Oil Drip Box

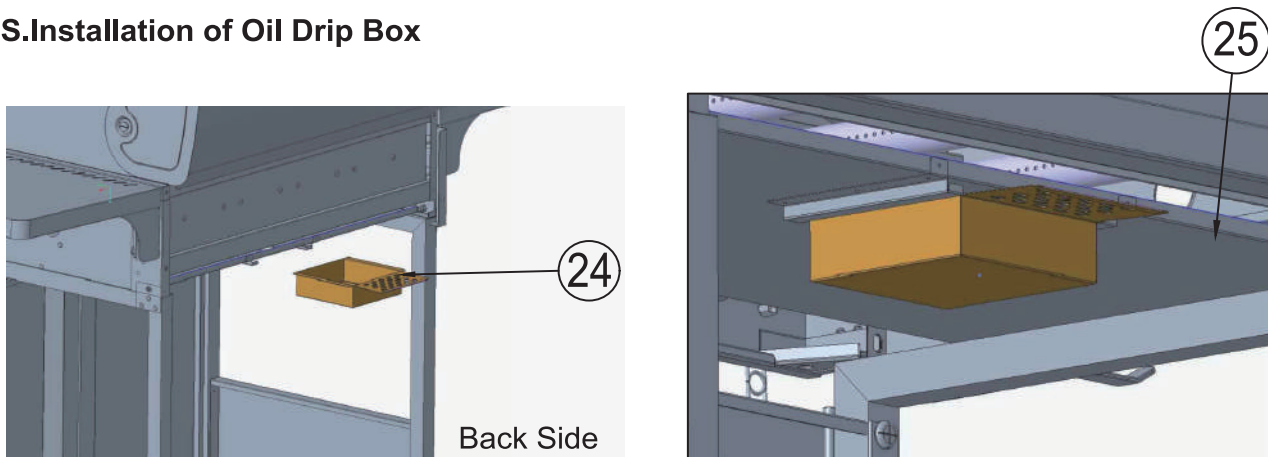

Insert the oil drip box (24) along the guide rail of the oil drip tray (25).

ASSEMBLY INSTRUCTIONS

T. Secure Gas Tank

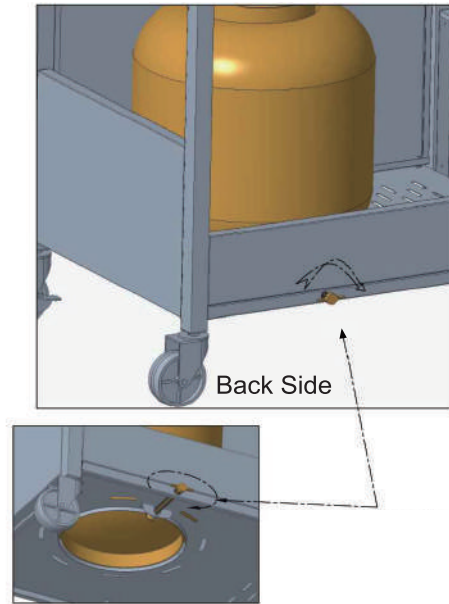

Open the two doors and place the gas tank into the nesting hole of the bottom panel. Clockwise tighten the butterfly screw on the back of the bottom panel to secure the gas tank in place.

U. Connect Gas Hose Assembly

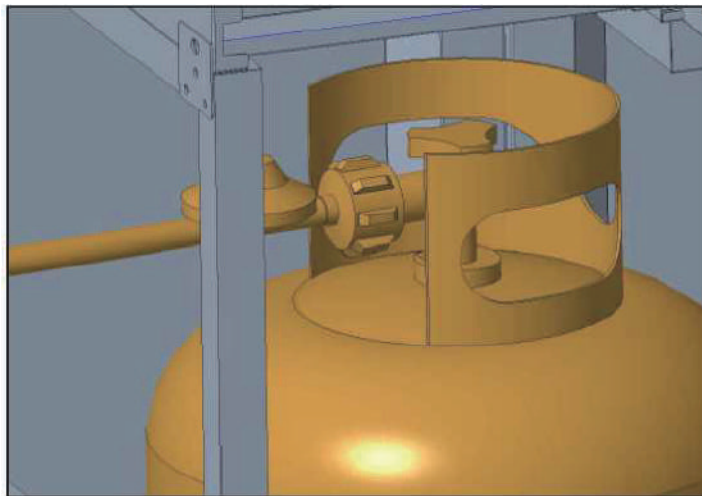

Back Side

Connect and tighten the regulator valve of the gas hose assembly to the threaded valve of the tank to ensure that there is no methane leakage.

ASSEMBLY INSTRUCTIONS

V. Installation of Battery

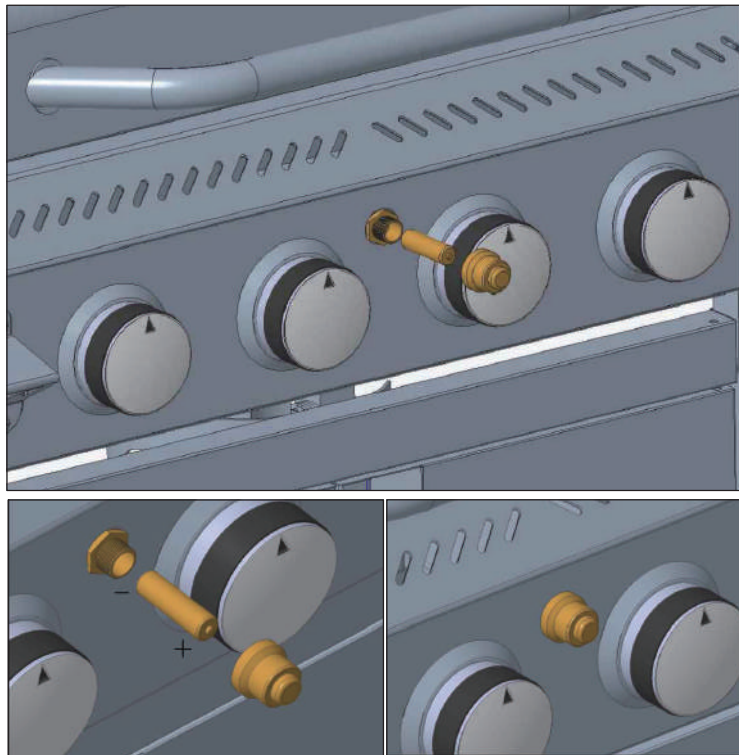

Screw the ignition button out, then insert the battery into the hole and screw the ignition button in.

Note: The "+" pole faces outward and the "-" pole faces inward.

Note: To ignite the burners, hold down and turn the gas control knob anticlockwise first to ensure that the gas in the tank is released, then press the ignition button for 3 to 4 seconds.

OPERATION INSTRUCTIONS

CHECKING FOR LEAKS

After all connections are made, check all connections and fittings on the threaded valve of the LP gas tank, gas hose and regulator valve for leaks with a water and soap solution.

To prevent fire or explosion while testing for a leak:

- Always perform leak test prior to lighting the grill.
- Do not smoke while testing for a leak.
- Always perform leak tests outdoors in a well-ventilated area.
- Do not use any source of flame while testing for leaks.
- Do not use the grill until any and all leaks are corrected.
- If you are unable to correct a leak, disconnect the propane supply and call a gas appliance service dealer.

PERFORM LEAK TEST

- Prepare leak test solution by 50/50 ratio of liquid dish soap and water. Total solution required is approximately 2 - 3 ounces (70 - 90 ml). Put leak test solution in a spray bottle.
- Ensure all control knobs are in the "O" (OFF) position.
- Connect the gas hose to the gas supply.
- Open the threaded valve of the LP gas tank.
- Spray leak test solution on all gas-carrying connections and fittings. Presence of bubbles at areas of applied test solution indicates a gas leak. If leaks are detected or you smell or hear gas, shut off the gas supply valve immediately and repair or replace the defective part. Do not use the grill until all leaks are corrected.

⚠ CAUTION

Only use the regulator valve and hose assembly provided! If a replacement is necessary, please call our customer service center. Do not use replacement parts that are not intended for this grill.

⚠ WARNING

ALL INSTRUCTIONS AND SAFEGUARDS ON THIS PAGE MUST BE FOLLOWED TO PREVENT FIRE, DAMAGE AND/OR INJURY.

OPERATION INSTRUCTIONS

CONNECTING GAS CYLINDER

The propane gas supply cylinder to be used must be constructed and marked in accordance with the Specifications for LP Gas Cylinders of the U.S. Department of Transportation (D.O.T.) or the National Standard of Canada, CAN/CSA-B339, Cylinders, Spheres and Tubes for Transportation of Dangerous Goods; and Commission, as applicable; and provided with a listed overfilling prevention device.

Use only 20-pound cylinders (height: 18.11 inches, tank diameter: 9.84 inches, foot diameter: 8.03 inches) equipped with a cylinder connection device compatible with the connection for outdoor cooking appliances.

The cylinder must include a collar to protect the cylinder valve. The gas cylinder should not be dropped or handled roughly!

If the appliance is not in use, the gas cylinder must be disconnected. Storage of an appliance indoors is permissible ONLY if the cylinder is disconnected and removed from the appliance. Cylinders must be stored outdoors out of the reach of children and can not be stored in a building, garage or any other enclosed area. Your cylinder must never be stored where temperatures can reach over 125°F.

Place the dust cap on the cylinder valve outlet whenever the cylinder is not in use. Only install the type of dust cap on the cylinder valve outlet that is provided with the cylinder valve. Other types of caps or plugs may result in leakage of propane.

Before connection, be sure that there is no debris caught in the outlet of the gas cylinder, outlet of the regulator valve or in the outlet of the burner and burner ports. Connect regulator valve and hand-tighten firmly. Keep the propane cylinder valve closed and disconnect the propane cylinder from the regulator valve when the grill is not in use.

DO NOT obstruct the flow of combustion air and ventilation air to the grill. The propane cylinder must be arranged for vapor withdrawal and equipped with a listed overfilling prevention device. Please use the proper cylinder orientation to provide vapor withdrawal.

NOTE: The cylinder must be fully upright for the cylinder to have vapor withdrawal only.

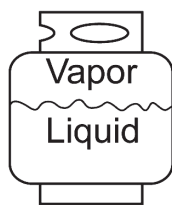

Correct



Wrong

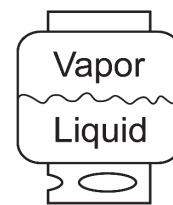

Wrong

⚠ CAUTION

- Do not store a spare LP-gas cylinder under or near this appliance.
- Never fill the cylinder beyond 80 percent full.
- If the information is not followed exactly, a fire causing death or serious injury may occur.



OPERATION INSTRUCTIONS

Note: Other cylinders may be acceptable with this appliance if they are compatible with the nesting hole and retention means of the appliance.

⚠ WARNING

ALL INSTRUCTIONS AND SAFEGUARDS ON THIS PAGE MUST BE FOLLOWED TO PREVENT FIRE, DAMAGE AND/OR INJURY.

CONNECTING THE LP TANK

1. The threaded valve on the LP tank must be closed. Make sure that the threaded valve is turned  clockwise to a full stop. The cylinder supply system must be arranged for vapor withdrawal.
2. Check that the control knob on the grill body is turned off.
3. Remove the protective cap from the LP tank valve and the regulator valve of the hose.
4. Hold the regulator valve in one hand and insert the nipple into the threaded valve outlet. Be sure the nipple is centered in the valve outlet. Use carefully – do not cross-thread the connection.
5. Hand-tighten the regulator valve  clockwise until it comes to a full stop. Firmly tighten it by hand only. Do not use tools.

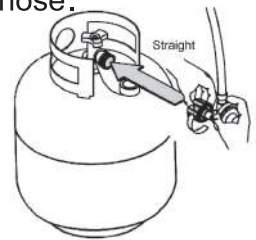

To Disconnect: Turn the regulator valve  counterclockwise until the regulator assembly detaches.

⚠ WARNING

In the connection process, make sure:

- the regulator valve inlet connector mates with the cylinder valve outlet properly, safely and firmly, and;
- the LP gas hose does not come in contact or remain in contact with the firebox.

OPERATION INSTRUCTIONS

Lighting The Grill

Before first use:

Remove all hangings or plastic straps, if present. Before you cook on your new gas grill, it is important to clean your grill with heat. To do this, operate the grill for approximately 15 minutes with the lid closed and the control knob in the highest position. This will clean the internal parts by burning off any residue and odor from the manufacturing process.

⚠ CAUTION

If the flame extinguishes accidentally during ignition or operation, immediately TURN OFF the cylinder valve and then TURN OFF the control knob.

⚠ WARNING

Do not lean over grill when lighting. Read instructions before lighting.

1. Check that the control knobs are at the "O" OFF position.
2. Open valve at tank fully by turning  counterclockwise.
3. Open the lid during lighting.
4. Hold down and turn the gas control knob anticlockwise first to ensure that the gas in the tank is released, then press the ignition button for 3 to 4 seconds. If ignition does not take place within 5 seconds, immediately turn the control knob to the "O" OFF position. Wait 5 minutes and repeat step 4 above or refer to fire rod lighting instructions in the next page.
5. Repeat step 4 above to ignite all other burners. If the burner still does not light, check that there is gas in the cylinder and follow the fire rod lighting instructions.
Check the Troubleshooting Guide for more information.

OPERATION INSTRUCTIONS

LIGHTING THE GRILL WITH THE FIRE ROD

1. Open the lid.
2. Insert the match between the circular wires of the fire rod.
3. Light the match.
4. Immediately place the lit rod through the spaces in the cooking grates near the ports of the burner between the grill, heat plates as shown. Make sure the lit rod is close to the burner ports.
5. Press in the control knob that operates the burner and rotate ↺ counter-clockwise to 🔥 High position and burner should light immediately.
6. Repeat 2–5 steps to light the remaining burners.
7. Adjust burners to desired cooking settings.

⚠ CAUTION

Make sure all burners controls are off except for the burner being lit and the burners that have been lit.

Fire Rod Lighting of Main Burner

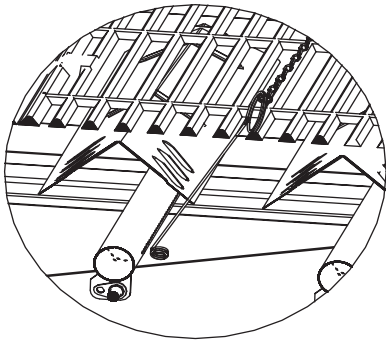

Fire Rod Lighting of Side Burner

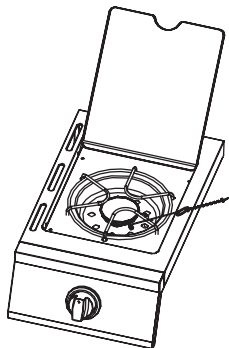

SHUTDOWN INSTRUCTIONS

1. Turn control knobs ↻ clockwise to the "O" OFF position.
2. Close threaded valve of the tank fully by turning ↻ clockwise.
3. Close the lid.

Turn off LP supply at the cylinder when the appliance is not in use.

CARE AND MAINTENANCE

Cooking Grates

The best time to “burn-off” the cooking grates is after every use (approx. 15 minutes). They are already hot from cooking thus requiring less fuel to obtain necessary temperature for “burn-off”.

To “burn off” or heat clean them, turn the burners to highest position and run for 15 minutes with the lid closed. Then turn off the burners and use a wire brush to clean excess food residue from the grates.

⚠ CAUTION

Ensure the grill is cool before cleaning and conducting maintenance and with the gas supply turned off at the LP-Gas Cylinder.

Recommended Cleaning Supplies: Mild liquid dish soap, warm water, nylon cleaning pad, wire brush

NOTE: DO NOT use cleaners that contain acid, mineral spirits or any abrasive substance.

Outside Surfaces

It is recommended to use only mild dish soap and hot water to clean grill and grill parts. Rinse with warm water.

Oil Drip Tray

To avoid flare-ups, the oil drip tray should be kept clean on a regular basis. Remove residue using a brush, scraper and/or cleaning pad. Wash with mild dish soap and warm water. Rinse with warm water. Avoid water splashing into venturi tubes of burners.

Grill Heat Plate

Clean residue with wire brush and wash with mild dish soap and warm water. Rinse with warm water.

Oil Drip Box

Empty the oil drip box and clean with mild dish soap and warm water on a regular basis.

Checking The Flame

For maximum fuel efficiency and cooking performance, flame should be a blue-yellow color and be between 1-2 inches high.

To check the flame, view the flame through the holes in both sides of the firebox.

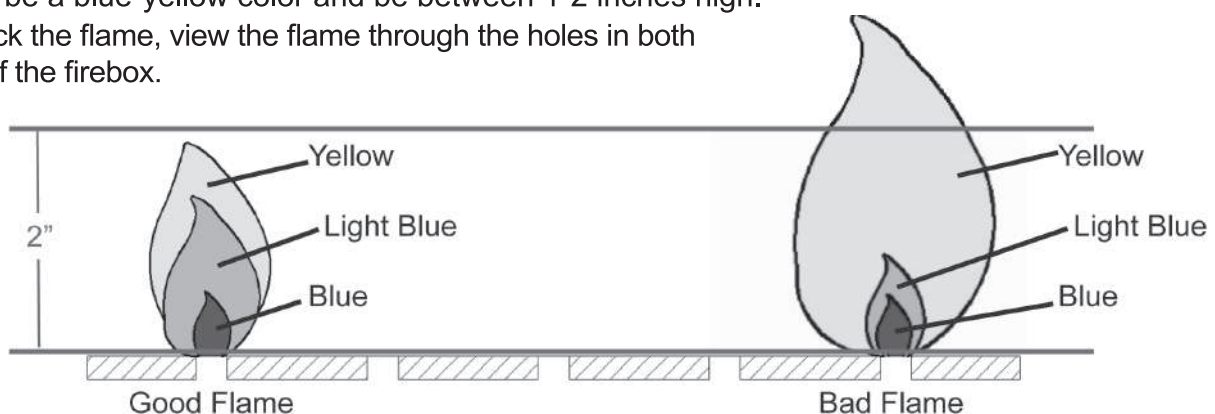

CARE AND MAINTENANCE

Removing The Burner Assembly - Make sure the grill is cool

1. Make sure all control knobs are in the "OFF" position, the gas supply valve is closed, and the gas hose is disconnected from the gas supply.
2. Remove the ignition button, remove the AA battery (1.5V) out, then screw the ignition button in.
3. Remove the warming rack, cooking grates, grill heat plate and burner rack.
4. Remove the hinge pins at end of the main burners as illustrated in Figure 1. Then remove the screws of the side burner.
5. Slide the main burners and the side burner out.
6. Detach the ignition wire from the electrode in Figure 2. DO NOT use pliers or any other tool as it may damage the electrode or wire.
7. Ensure all burner ports are clear of clogs. Use of a pin or a paper clip works well.
8. Ensure the burner is free of any damage. If any damage is found, replace it with a new burner.
9. Ensure the end of the burner and the primary air screen at the back of the grill body are clear of insect nests, dirt or debris.

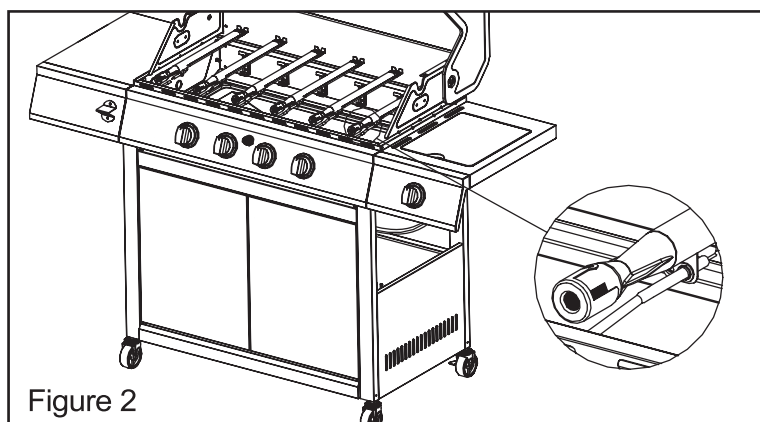
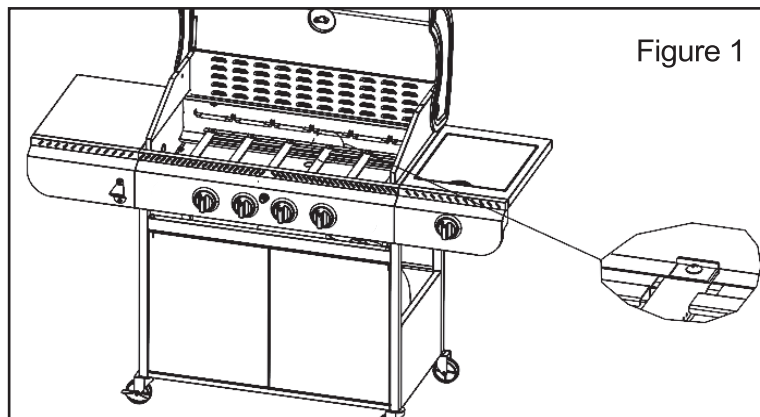

CARE AND MAINTENANCE

Re-installing the Burner Assembly

1. Ensure that gas valve orifices inside the grill body are correctly positioned inside burner inlet (venturi) as shown below.
2. The use of a flashlight may be necessary to ensure the correct position.
3. It is recommended to view the correct position through the firebox vent holes.
4. Reattach each burner with the hinge pin and reattach the ignition wire to electrode.
5. Ensure that the side burner is correctly attached to the valve of the hose and reattached on the right burner table with screws.

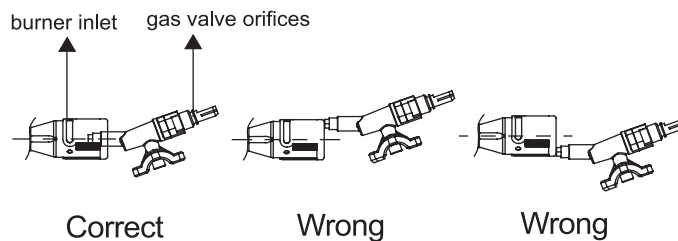

⚠ WARNING

If the instructions above are not followed, a fire or explosion may result, possibly causing serious bodily injury.

Other Care and Maintenance

Maintenance Instructions (including recommended frequency guidelines) relative to:

- 1) Keeping outdoor cooking gas appliance areas clear and free from combustible materials, gasoline, and other flammable vapors and liquids.
- 2) Not obstructing the flow of combustion and ventilation air.
- 3) Keeping the ventilation opening(s) of the cylinder enclosure free and clear from debris.
- 4) Visually checking burner flames including pilot burner flame if provided
- 5) A statement indicating that other cylinders may be acceptable for use with the appliance provided they are compatible with the appliance retention means and accompanied by illustration(s) depicting the cylinder mounted to the appliance utilizing the cylinder retention means and the point of contact between the cylinder and the retention means.
- 6) Checking and cleaning burner/venturi tubes for insects and insect nests. A clogged tube can lead to a fire beneath the grill.

* It is highly recommended to conduct maintenance at least once a year.

The electronic ignition requires 1 “AA” alkaline battery, which is included.

⚠ WARNING

DO NOT mix old and new batteries.
DO NOT mix alkaline, standard (Carbon-Zinc), or rechargeable (Nickel-Cadmium) batteries.
DO NOT dispose of batteries in fire. Improper disposal may cause batteries to leak or explode.

TROUBLESHOOTING

PROBLEM	POSSIBLE CAUSE	CORRECTIVE ACTION
<p>The burner does not light by using the ignitor procedure (weak or no sparking generated).</p>	<ol style="list-style-type: none"> 1. The ignition electrode may be covered with grease or residue. 2. The ignition electrode may have a loose or disconnected wire. 3. Cracked or broken ignition electrode. 4. Dead battery or faulty battery connection. 	<ol style="list-style-type: none"> 1. Clean the ignition electrode. 2. Check the connection and reconnect any loose or disconnected wire. 3. Replace the ignition electrode. 4. Perform any of the following: <ol style="list-style-type: none"> a. Replace the battery. b. Check to see if the battery is inserted correctly. c. Check for any corrosion around battery terminals.
<p>Low Heat.</p>	<ol style="list-style-type: none"> 1. Insufficient gas pressure to the unit. 	<ol style="list-style-type: none"> 1. Call a qualified service agency to check the gas supply pressure and correct the pressure.
<p>Excessive Flare Ups.</p>	<ol style="list-style-type: none"> 1. Grease and/or residue build-up on grill heat plates or in firebox. 2. Excessive dripping of fat or marinade from food. 3. Cooking temperature too high. 	<ol style="list-style-type: none"> 1. Clean the grill components. 2. Shed the fat from meat and use non-oil based marinades. 3. Lower temperature accordingly.

TROUBLESHOOTING

PROBLEM	POSSIBLE CAUSE	CORRECTIVE ACTION
<p>The burner will not light with the fire rod</p>	<ol style="list-style-type: none"> 1. The rod does not reach burners (when holding the rod with hand). 2. Empty tank. 3. Poor connection between the regulator valve and the threaded valve of the LP gas cylinder. 4. Burner inlet blocked. 	<ol style="list-style-type: none"> 1. Use the fire rod correctly as instructed in LIGHTING THE GRILL WITH THE FIRE ROD section. 2. Check the fuel level and replace the tank if necessary. 3. Turn off grill knobs, close the cylinder valve and check the connection between the regulator valve and the threaded valve of the LP gas cylinder. Disconnect and reconnect, if necessary. 4. Clean the burner inlet (venturi) and the burner as described by Care and Maintenance section in the manual.
<p>No gas flow or an obstructed gas flow.</p>	<ol style="list-style-type: none"> 1. Tank valve not on or fully opened. 2. Empty tank. 3. Poor connection between the valve regulator and the LP cylinder coupling. 4. Burner inlet blocked. 	<ol style="list-style-type: none"> 1. Fully open the tank valve by turning counterclockwise. 2. Check the fuel level and replace the fuel if necessary. 3. Turn off grill knobs, close the LP cylinder valve and check the regulator valve and the threaded valve of the LP gas cylinder. Disconnect and reconnect, if necessary. 4. Clean the burner inlet (venturi) and burners as described by Care and Maintenance section in the manual.

ROWAN ELECTRIC APPLIANCE LLC

8:30am-5:30pm P.S.T.
Monday to Friday



Web: www.electacticshop.com



Email: service@electacticshop.com



Tel: 888-698-2504