

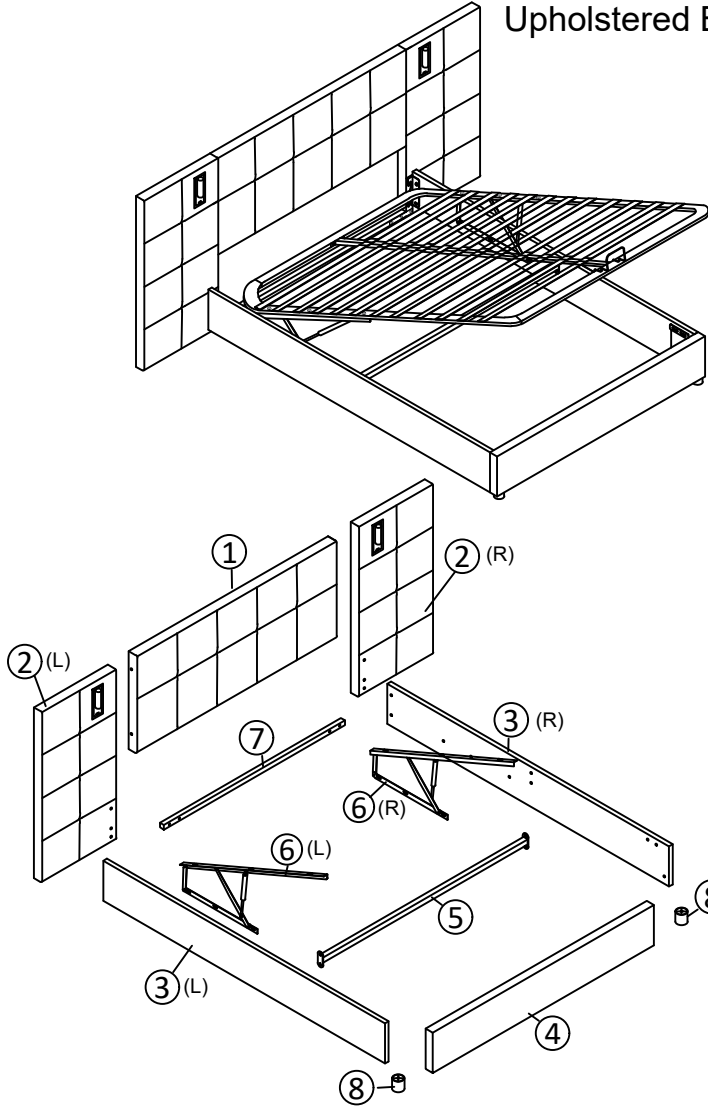









ASSEMBLY INSTRUCTION

Upholstered Bed:152*200CM





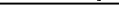

TIPPS

1. This set comes in 2 boxes. If you don't receive a full 2 boxes, please contact our customer service.
2. Please read the instructions fully before assembly. These instructions include important information which could ensure correct assembly. We have been working on providing high quality products for you. However, in the rare instance that your product is defective, missing parts or there are some issues, please don't hesitate to contact our customer service to submit parts requirements, assembly suggestion, or warranty claims, and we will give the best solution as soon as possible. If necessary, we need you to provide some more clear pictures of the issue.
3. Insert the screws in holes and tighten the screws, but not too tight, 70%~80% is ok, finally tighten all the screws. If some issues happened that some screws can not target to the hole or some parts are difficult to install, please adjust the tightness of the screws.
4. 2 people are recommended to finish.

Parts List			Hardware List		
NO	ITEM	QTY	NO	ITEM	QTY
1	Head board	1	A	Allen Key 	1
2	Side head board	2	B	Bolts (M8x45mm) 	18
3	Siderails	2	C	Hinge 	2
4	Foot board	1	D	Bolts (M8x18mm) 	38
5	Cross bar	1	E	Washer 	4
6	Gas lift	2	F	Three hole iron 	2
7	Head board cross bar	1	G	Little "7" Connector 	2
8	Bed legs	2	H	Metal Corner 	2
9	Non woven fabric	1	I	Nails (M4x50mm) 	2
10	Slat frame	1	J	"7" Connector 	1
			K	Nuts 	4
			L	Spanner 	1
			M	Nuts 	14
			N	Middle slats cap 	12
			O	End slats cap 	24
			P	Stopper 	1
			Q	Power line 	1
			R	Power adapter 	1

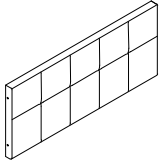
Part List

Hardware List+WF532062AAG

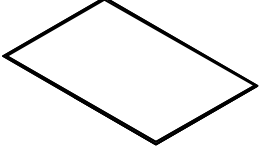
<p>1</p>  <p>Head board -1pc</p>	<p>2</p>  <p>Side head board -2pcs</p>	<p>6</p>  <p>Gas lift -2pcs</p>
<p>8</p>  <p>Legs -2pcs</p>	<p>9</p>  <p>Non woven fabric -1pc</p>	

Part List

WF532063AAG

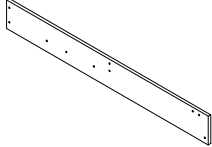
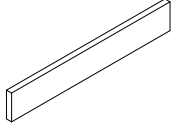
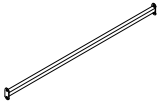
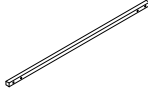
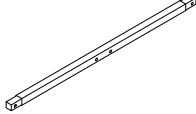
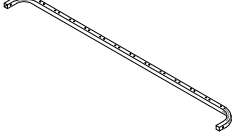
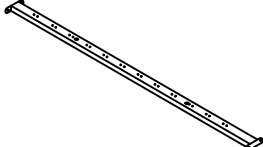
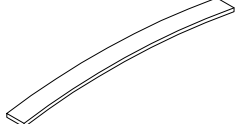
<p>3</p>  <p>Side rails -2pcs</p>	<p>4</p>  <p>Foot board -1pc</p>	<p>5</p>  <p>Cross bar -1pc</p>
<p>7</p>  <p>Head board cross bar -1pc</p>	<p>10.1</p>  <p>Metal frame cross bar-2pcs</p>	<p>10.2</p>  <p>Metal frame side bar-2pcs</p>
<p>10.3</p>  <p>Metal frame middle bar-1pc</p>	<p>10.4</p>  <p>Slat-24pcs</p>	

Attention: Do not tighten the screws before completing the entire installation. If you have any difficulty with the installation process, please feel free to contact us.

Step 1

Fix the side headboard ② to the headboard ① with Bolts B and Washers E by using Allen key A

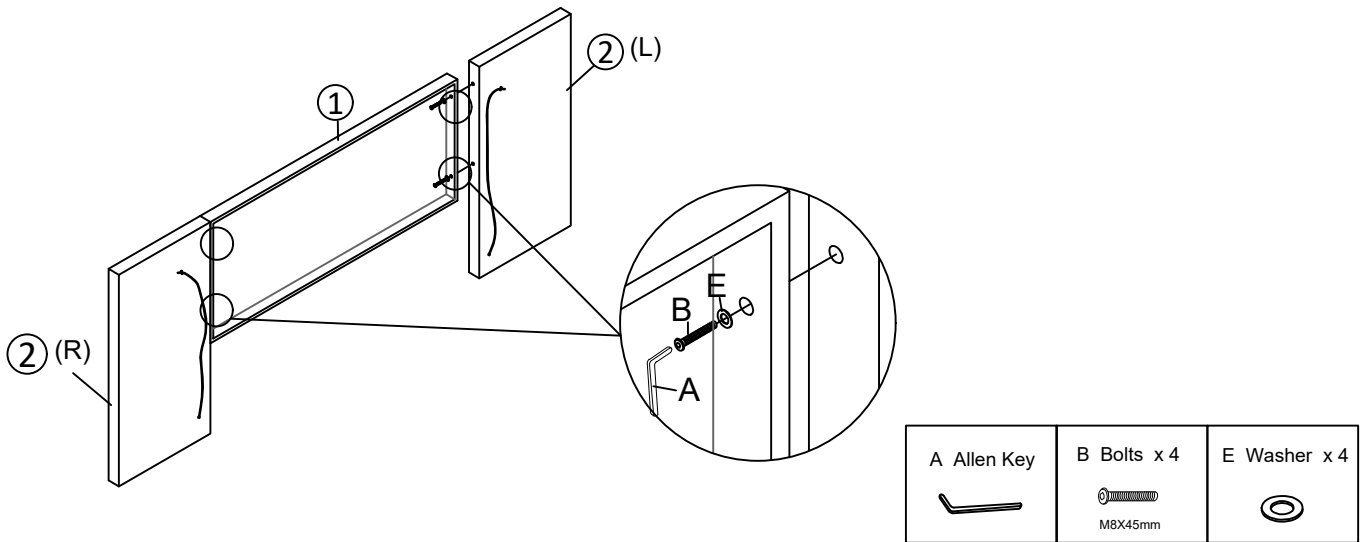

Step 2

Fix the headboard cross bar ⑦ to the side headboard ② with Bolts D and Three hole iron F by using Allen key A

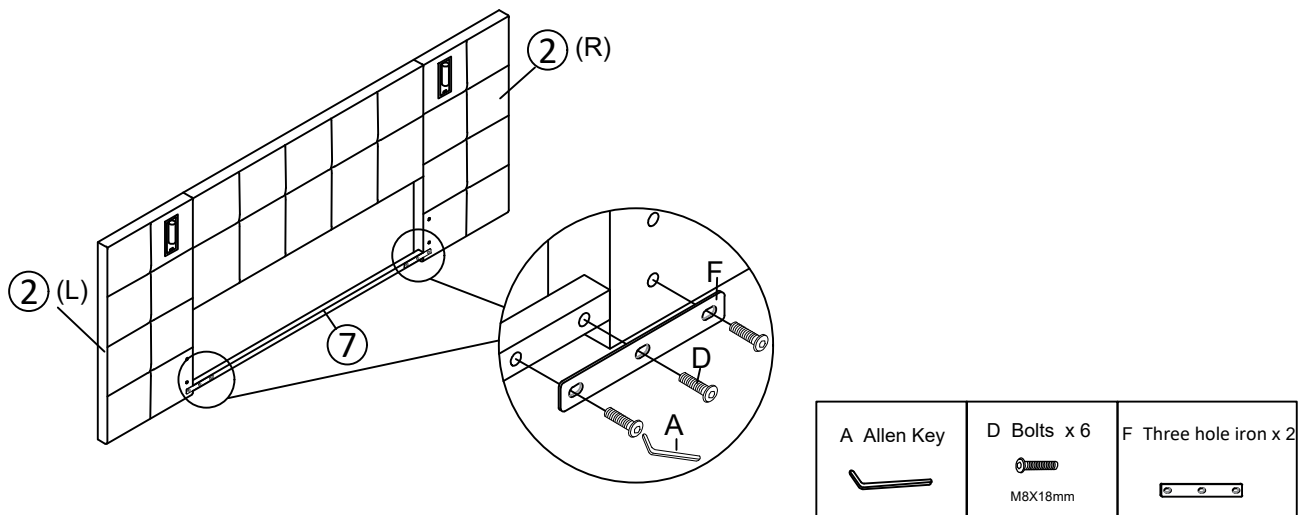

Step 3

Fix the side rails ③ to the side headboard ② with Bolts D and Hinges C by using Allen key A

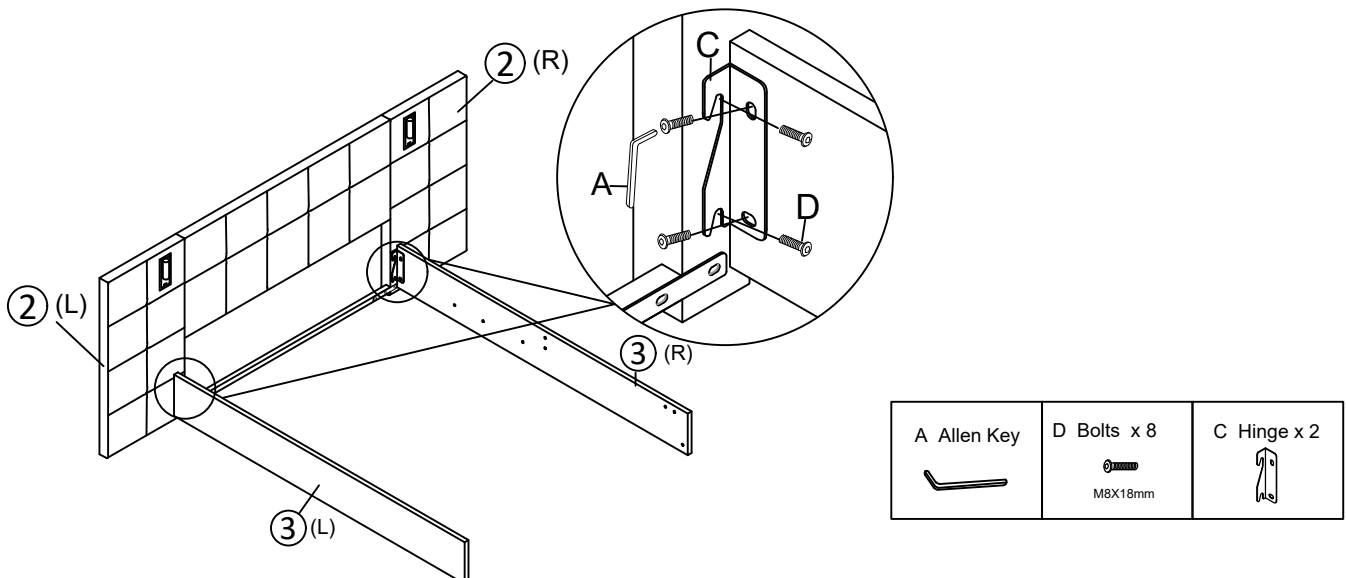

Step 4

Fix the Siderails ③ to the footboard ④ with Metal corner H, Little "7" Connector G and Bolts D by using Allen key A.

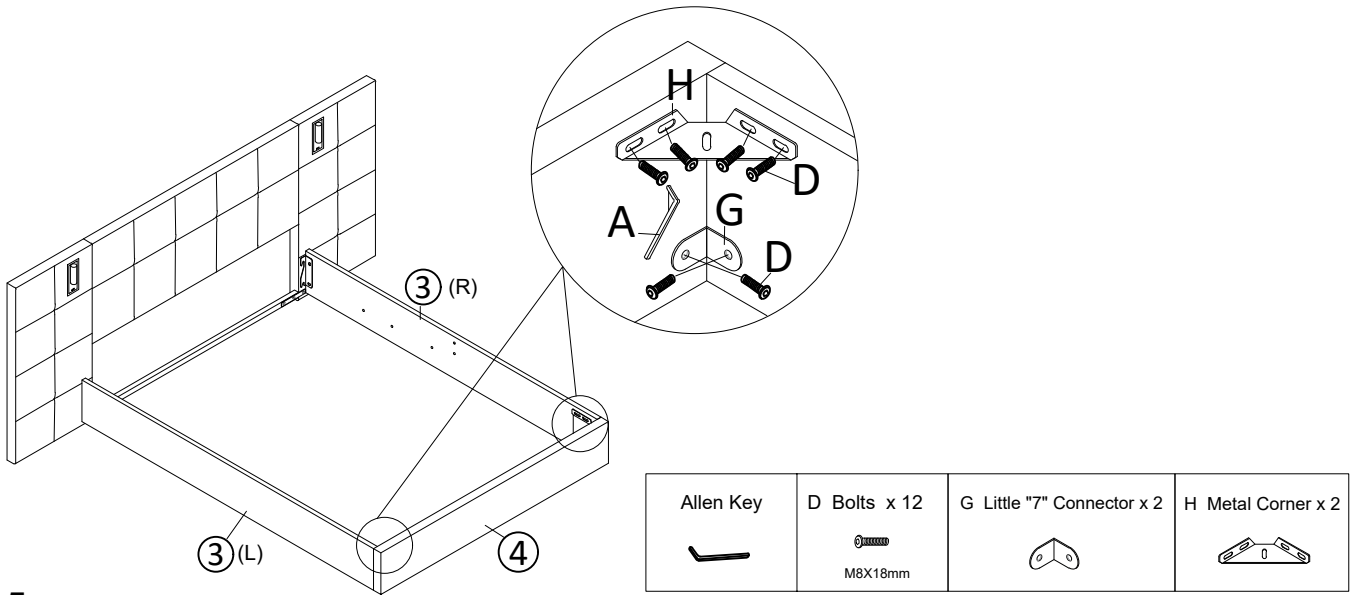

Step 5

Fix the "7" Connector J to the footboard ④ with with Bolts D by using Allen key A.

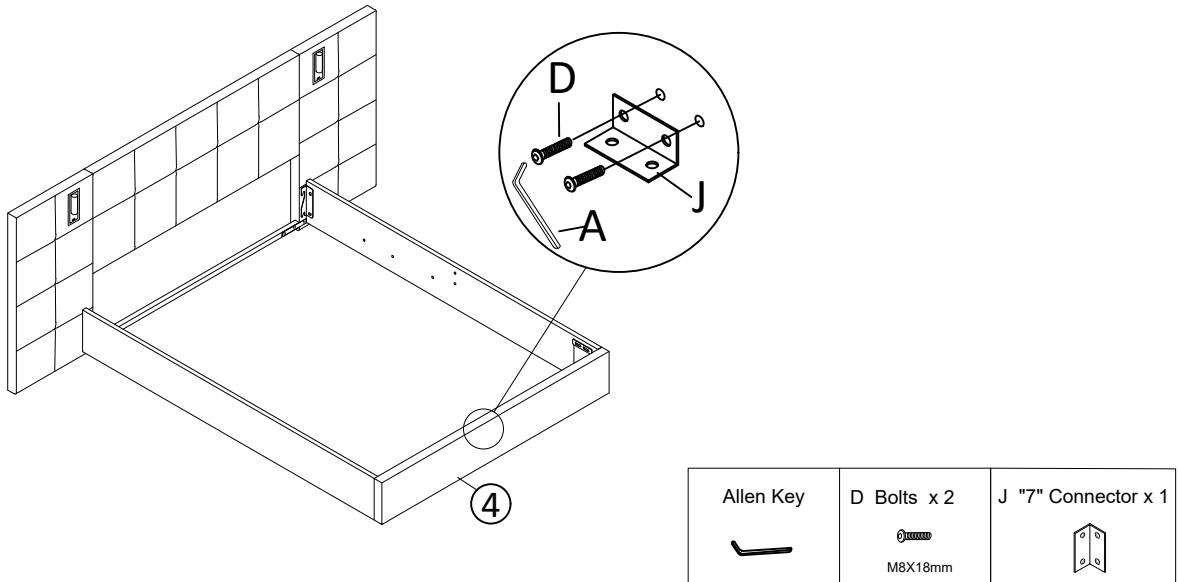

Step 6

Stick the black non-woven fabric ⑨ To the bottom of the bed .

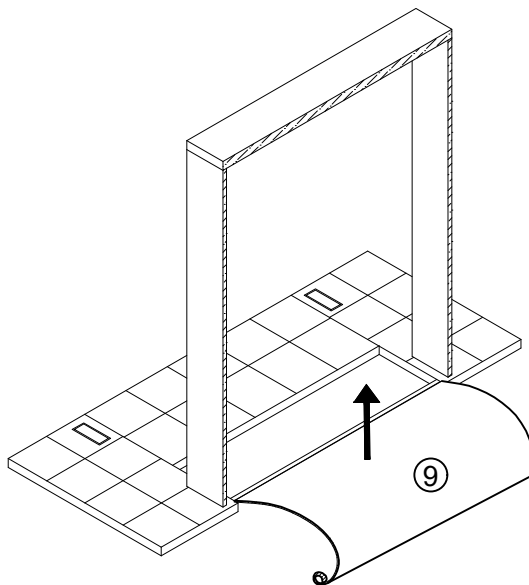

Step 7

Fix the legs ⑧ to the bottom of footboard ④ with nails I by using electric drill or screw driver

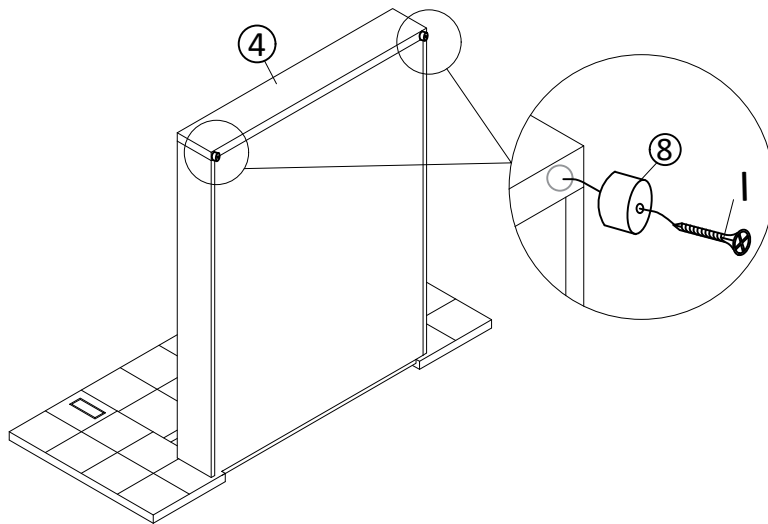

Step 8

Fix the gas lifts ⑥ to the Siderails ③ with Blots D by using Allen Key A or electric drill. fix the gas bar to the gas lifts ⑥ with Nuts K.

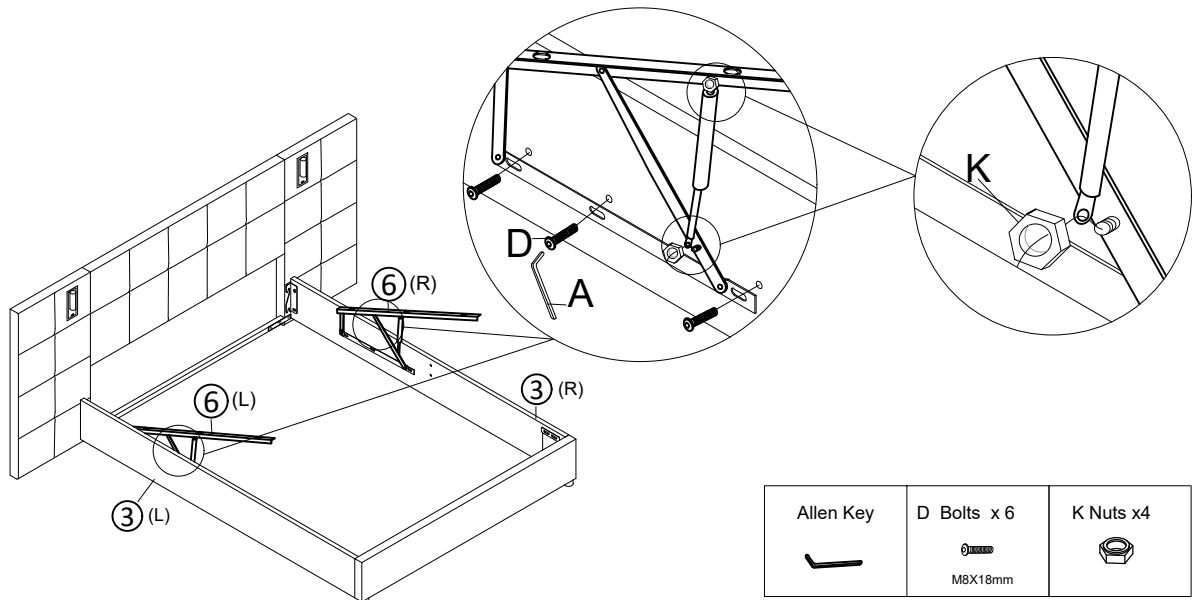

NOTICE:

The hole on the gas list is oval, please make sure that Please ensure that the installation positions on the left and right are roughly the same, if you accidentally install the gas lift one side to the front and the other to the back, which affects your use, you can write it down and reinstall it.

Step 9

Fix the cross bar ⑤ to the Siderails ③ with Bolts D by using Allen Key A.

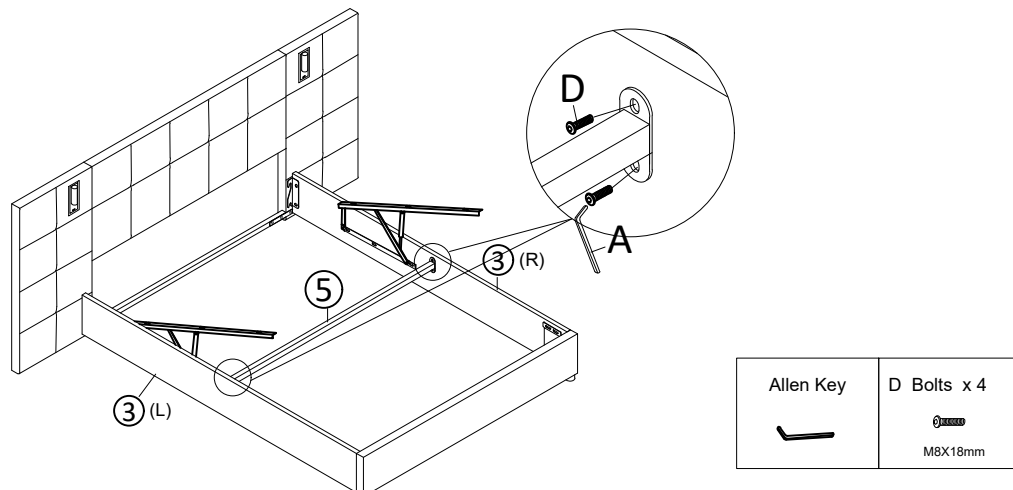

Step 10

Assemble the slats frame with Bolts B and Nuts M by using Spanner L and Allen Key A.

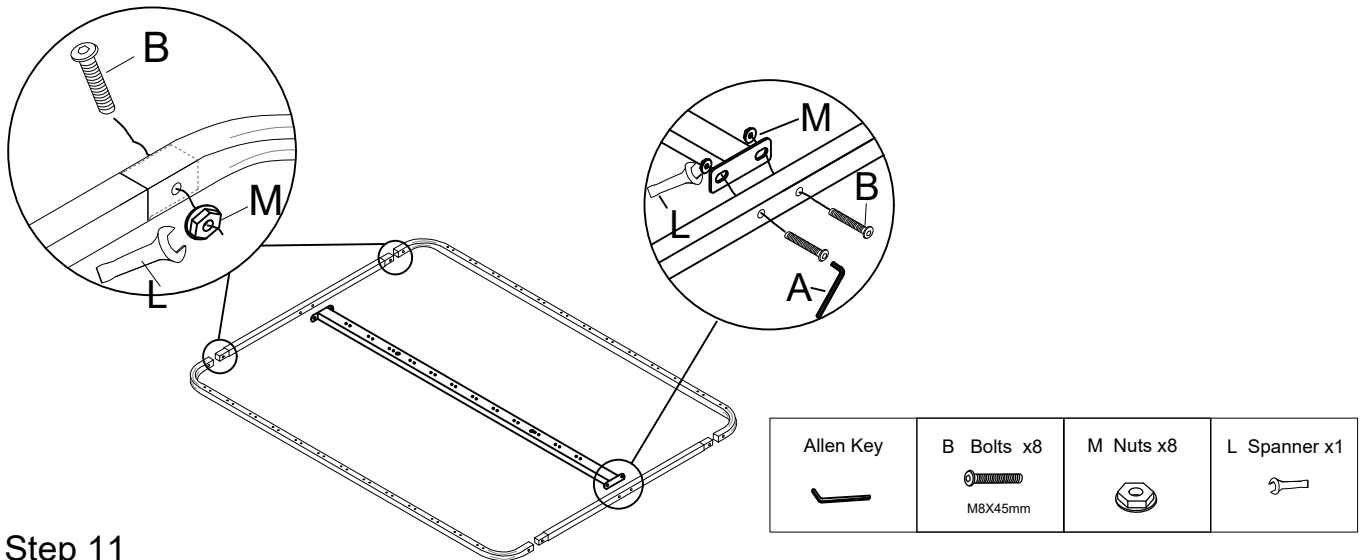

Step 11

Assemble the slats into the assembled slats frame with middle slats cap N and end slats cap O.

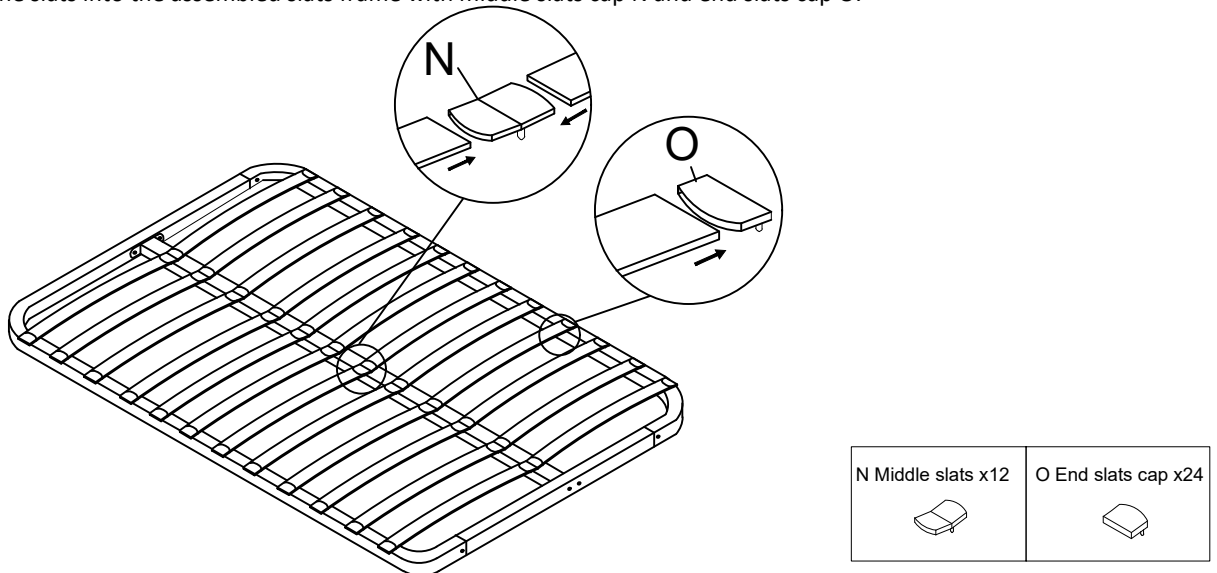

Step 12

Assemble the slats frame to the gas lifts ⑥ with bolts B and nuts M, put the stopper P in the end of the slat frame, now please tighten all hardware, then assemble is finished.

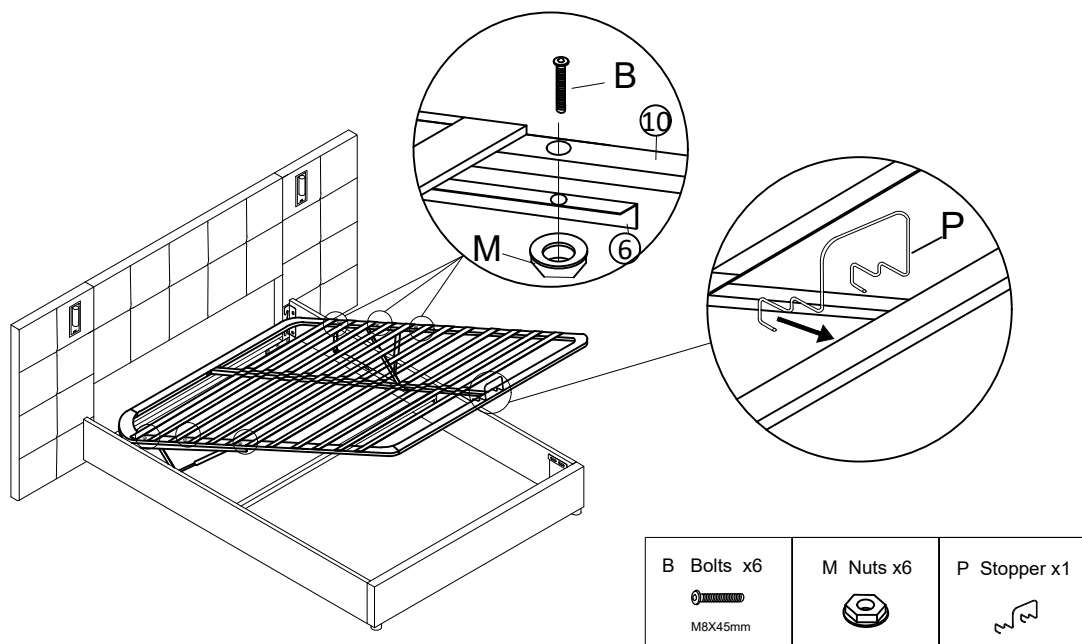

Step 13

At first connect the Power adapter R to the Power line Q, then connect the Power line Q to the line of reading lamp. At last connect the power and enjoy your bed.

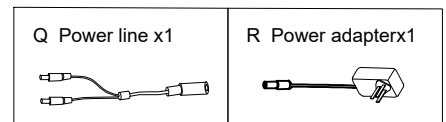
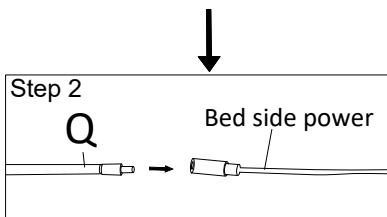
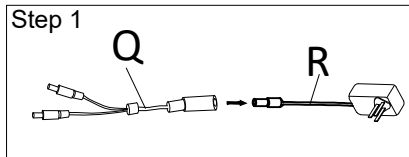
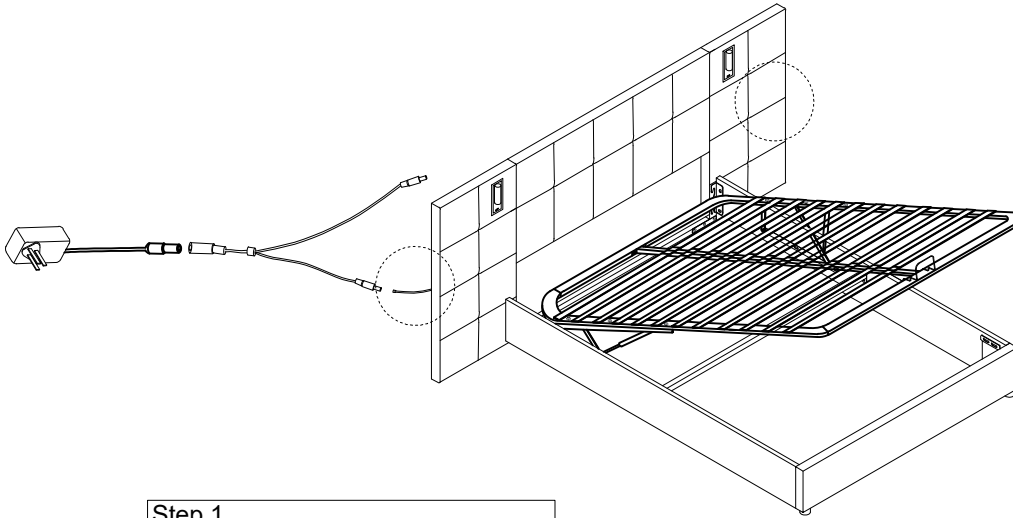

Verification of Compliance

Verification No.:	MK23020083-P01E01
Name and address of Applicant:	Shenzhen Hongzhengyu Technology Co., LTD Shenzhen baoan district rock street industrial science and technology industrial park of 2 Haitian lanyu 3 5 floor of A
Name and address of Manufacturer	Shenzhen Hongzhengyu Technology Co., LTD Shenzhen baoan district rock street industrial science and technology industrial park of 2 Haitian lanyu 3 5 floor of A
Product name:	Lamp strip
Rated:	— 1A
Product model(s):	HZY-2835-120D-12V, HZY-2835-30D-5V, HZY-2835-60D-5V, HZY-2835-120D-5V, HZY-2835-60D-12V, HZY-2835-60D-24V, HZY-2835-120D-24V, HZY-2835RGB-60D-5V, HZY-2835RGB-60D-12V, HZY-5050-30D-5V, HZY-5050-60D-5V, HZY-5050-30D-12V, HZY-5050-60D-12V, HZY-5050-60D-24V, HZY-5050RGB-30D-5V, HZY-5050RGB-60D-5V, HZY-5050RGB-30D-12V, HZY-5050RGB-60D-12V, HZY-5050RGB-60D-24V
Product trademark:	N/A

This verification confirms that the product meets the requirements of the following standard.

The conformity was demonstrated based on following standard(s) listed by European Commission as harmonized with EMC Directive 2014/30/EU.

EN IEC 55015:2019+A11:2020

IEC 61547:2020

The verification has been carried out in accordance with individual rules and conditions agreed with the applicant. Evaluation has been carried out in accordance with:

Test report(s) No.: MK23020083-P01E01

Test conducted by: TMC Testing Services (Shenzhen) Co., Ltd.

Verification issue date: February 25, 2023

Notes:

This verification refers to the above mentioned product and its conformity in regards of above mentioned standard(s) was proven on test sample.

This verification does not imply meeting all essential requirements, assessment of the series-production or any other restricted Notified Bodies conformity assessment procedure appropriate for the product.

This verification holder shall use this verification in connection to verification of conformity and technical data relevant for the product the verification was issued.

TMC Testing Services (Shenzhen) Co., Ltd.

t:86-755-86642861 cert@tmc-lab.com www.tmc-lab.com

1st Floor, Block A1, Zone A, Xinshidai Gongrong Industrial Park, No. 2, Shihuan Road, Shiyuan Street, Baoan District, Shenzhen, China



Lab Director

Vivian Jiang





CERTIFICATE OF CONFORMITY

Electromagnetic Compatibility Regulations 2016

This Certificate of Conformity is hereby issued to the product designated below:

Certificate No...... : 21EP12116E01
Report No...... : EP2112116E01
Date Issue. : 2022-01-17
Applicant's name : Huizhou Guoatong Technology Co., Ltd
Address..... : 4F(plant E), 4F(Plant C), 4F&5F(plant B), 2 Runze Rd. Huinan South High-tech Industrial Park. Huiao Avenue. Huizhou, Guangdong, China
Manufacturer's name : Same as applicant
Address..... : Same as applicant
Product Description..... : POWER ADAPTER
Model(s)/Type References : GA-XXXYYYYW, GAT-XXXYYYYW
(“XXX”, “YYYY” and “W” are variables, see following page for details)
Parameters..... : Input: 100-240V~, 50/60Hz, 0.6A Max
Output: 3.0-24.0Vdc, 0100-2000mA, 12.0W Max.
Standard(s) : BS EN 55032:2015+A11:2020
BS EN 55035:2017+A11:2020
BS EN IEC 61000-3-2:2019+A1:2021
BS EN 61000-3-3:2013+A1:2019

On the basis of the referenced test report(s), sample(s) tested of the above product have been found to comply with the standards harmonized with the directives listed on this verification at the time the tests were carried out. Other standards and Directives may be relevant to the product. This verification is part of the full test report(s) and should be read in conjunction with it(them).

Once compliance with all product relevant UKCA mark directives are verified, including any relevant e.g. risk assessment and production control, the manufacturer may indicate compliance by signing a Declaration of Conformity themselves and applying the mark to products identical to the tested sample(s).

Approved By

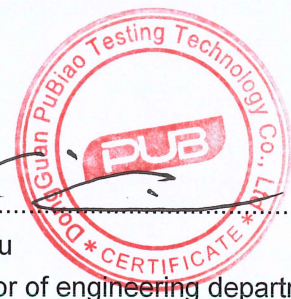
Eric Liu
Director of engineering department



CERTIFICATE OF CONFORMITY

Electromagnetic Compatibility Regulations 2016

Appendix of Certificate No.: 21EP12116E01

Table A: Definition of variables

Variable:	Range of variable:	Content:
XXX	030-240	Which stands for the rated output Voltage from 3.0Vdc to 24.0Vdc, minimum step by 0.1 Vdc.
YYYY	0100-2000	Which stands for the rated output current from 100mA to 2000mA, minimum step by 100mA.
W	V, Y	"V" "Y" means UK plug

Table B: Model list and output rating

Model	Rated output voltage (VDC)	Rated output current (mA)	Max. rated output power (W)	Transformer (T1)
GA-XXXYYYYYW, GAT-XXXYYYYYW	3.0-5.0	0100-2000	10.0	EF15-5V
	5.1-12.0	0100-1000	12.0	EF15-12V
	12.1-24.0	0100-1000	12.0	EF15-24V

