

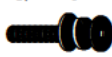

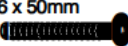



ASSEMBLY INSTRUCTIONS

IMPORTANT NOTE :

- * PLACE ALL WOODEN PARTS ON A CLEAN AND SMOOTH SURFACE SUCH AS A RUG OR CARPET TO AVOID THE PARTS FROM BEING SCRATCHED.
- * BEFORE YOU BEGIN, KINDLY FOLLOW THE ASSEMBLY INSTRUCTIONS STEP BY STEP.
- * DO NOT TIGHTEN ALL SCREWS UNTIL THE CHAIR IS FULLY SET-UP.

HARDWARE LIST		PART LIST	
A	JCBC M6 x 25mm + S/W M6 + F/W M6 x 13mm  4PCS	1	TOP REST UP 1PC
B	JCBC SCREW M6 x 50mm  4PCS	2	TOP REST DOWN 1PC
C	BARREL NUT M6 x 13mm  4PCS	3	FRONT STRETCHER 1PC
D	ALLEN KEY M4  1PC	4	BACK STRETCHER 1PC
E	L BRACKET  4PCS	5	RIGHT SIDE FRAME 1PC
F	PH SCREW M4 x 12mm  8PCS	6	LEFT SIDE FRAME 1PC
G	WOOD DOWEL M8 x 25mm  2PCS	7	CUSHION SEAT 1PC

CAUTIONS :

(1) DO NOT FULLY-TIGHTEN THE NUT OR NUT BOLTS INITIALLY UNTIL ALL NUTS OR BOLT IS READY ASSEMBLED.

(TO AVOID CAUSING DAMAGES TO THE THREAD, DO NOT OVER-TIGHTEN THE NUTS OR BOLTS.)

(2) KEEP ALL HARDWARE PART OUT OF REACH OF CHILDREN.

STEP 1

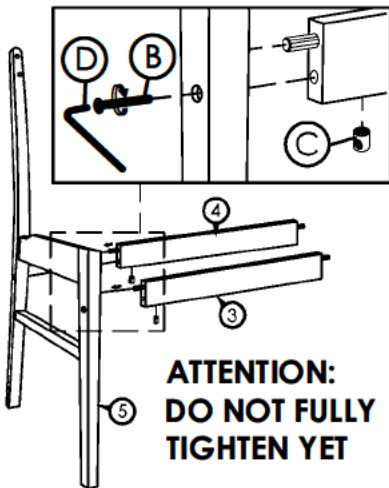

STEP 2

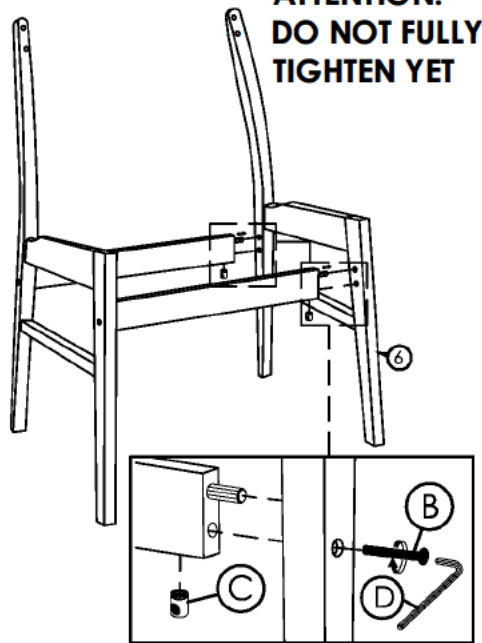

STEP 3

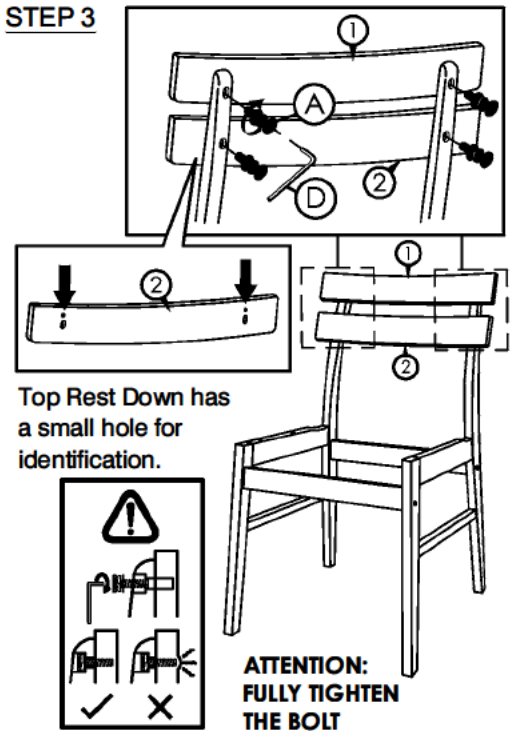

STEP 4

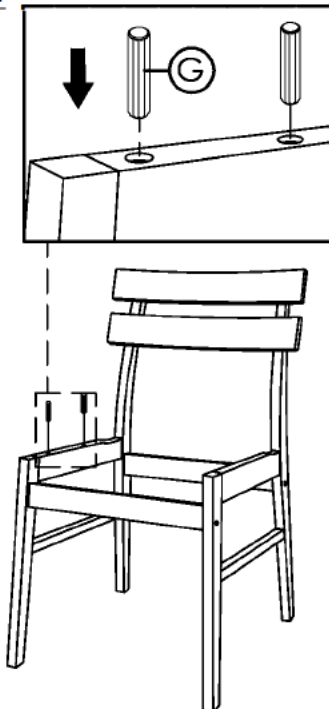

STEP 5

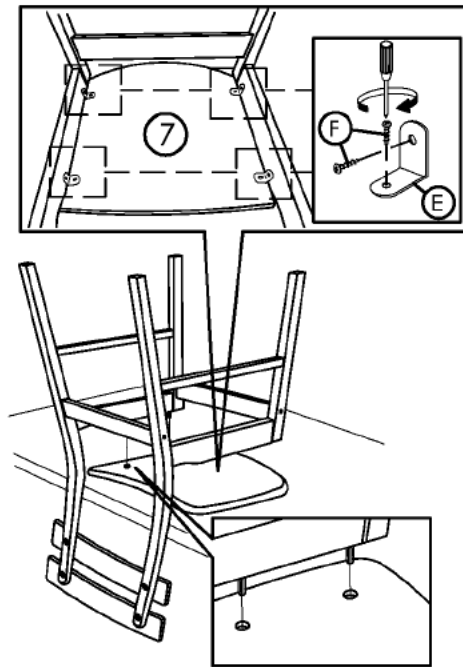

STEP 6

