



Always Comfortable.™



**Assembly
Instructions**

Serta Works Office Chair

So comfortable, you'll feel the difference the moment you sit down.

Should you prefer to
speak with a customer
service representative,
you may call toll free :

**1-855-372-2315 U.S. 6am - 5pm PST,
0-800-051-6775 U.K. 2pm - 1am**

Guidelines

FAILURE TO FOLLOW THESE WARNINGS WHEN IN USE COULD RESULT IN INJURY

- Do not stand on the item or use as a step ladder
- The piece has been tested and approved for users weighing up to 250 lbs (113kg) per seat.
- Do not use this item unless all bolts and screws are firmly secured and fastened.
- Check all bolts and screws every 90 days. As necessary tighten if any are loose.
- Lift up then move. Pushing over or dragging this product can result in an injury or cause damage to the floor and piece.

Pre-Assembly Preparation:

Please read through this instruction booklet before beginning assembly of this item.

Two adults are recommended for assembly.

- Clear out the space for assembly and lay out all parts on Parts List, extra room will allow you to easily determine if all the pieces are present.
- Save all packing materials until assembly is complete to avoid accidentally discarding smaller parts or hardware.
- Keep small parts and pieces away from children and pets until fully assembled.
- Please check for any loose screws and tighten them before you use.

WARNING: DO NOT LET CHILDREN PLAY IN OR AROUND THE UNIT DUE TO THE POSSIBLE RISK OF INJURY.

Parts List



(1) Casters x 5

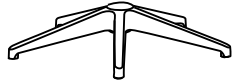

(2) 5 Star Base x 1

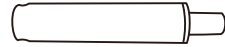

(3) Gas Lift x 1

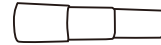

(4) Telescoping Cover x 1

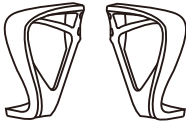

(5) Left & Right Arm



(6) Seat Cushion x 1

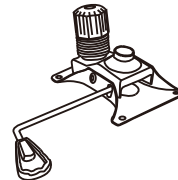

(7) Seat Plate x 1



(8) Back Cushion x 1



(9) M6x35MM x 6



(10) M6x20MM x 4



(11) M6x45MM x 4



(12) Allen Key x 1

- Step 1--**
1. Ensure all parts have been removed from the carton and place on a protected surface or carpet.
 2. Check all parts and hardware are the same as the “Parts List”.
 3. To begin assembly, place 5 Star Base (2) upside down and insert Casters (1) into bottom of Base (2).
 4. Turn Base (2) right side up on the floor and insert Gas Lift (3) into center hole on Base (2).
 5. Place Telescoping Cover (4) over the Gas Lift (3) and rest it on the Base (2).

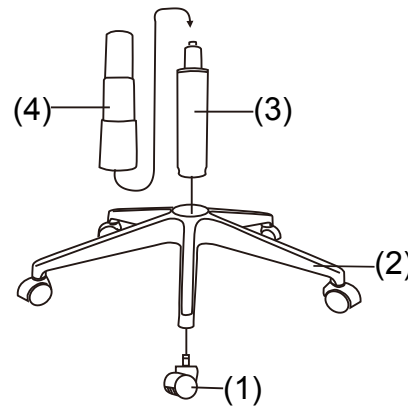

Step 2 -- Fasten Arms (5 L & 5 R) onto sides of Seat Cushion (6) by using M6x35 MM Screws (9). Then fasten with Allen Key (12).

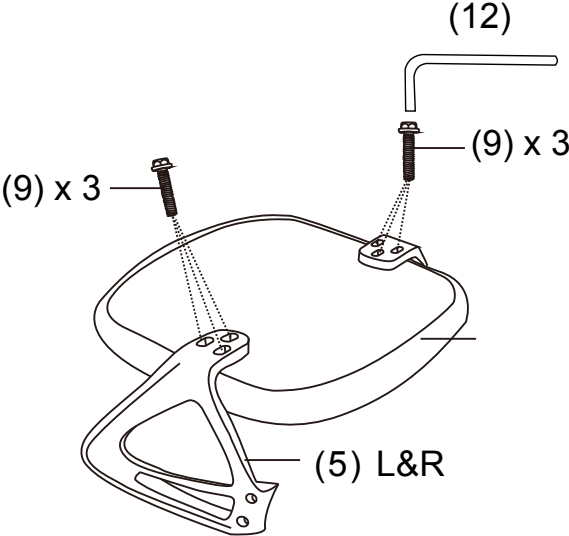

Step 3 -- Attach Seat Plate (7) onto the bottom of Seat Cushion (6) (with front of seat plate facing front of seat cushion) by using M6X20MM Screws (10) in the holes of Seat Plate (7) and tighten screws with Allen Key (12).

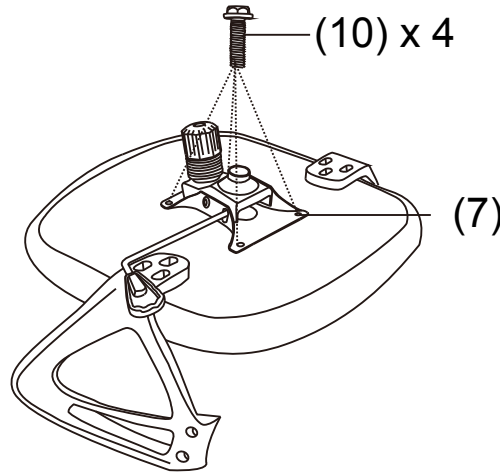

Step 4-- Place the Back Cushion (8) Between Arms (5), and use M6X25MM Screws (11) to locate screw holes on both Arm (5) & Back Cushion (8) as Diagram. Tighten all screws by Allen Key (12).

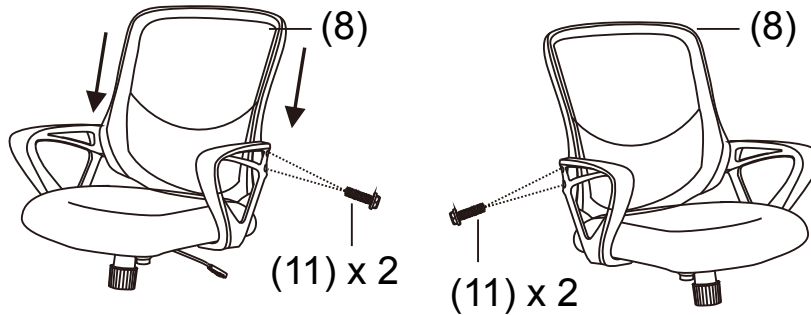

Step 5-- Place the assembled Seat Cushion (6) with Seat Plate (7) on top of Gas Lift (3) and press down until fully engaged.

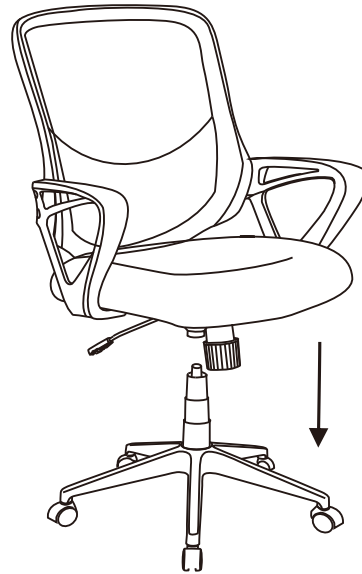

Step 6-- Periodically (every 90 days) make sure that the screws are still fully tightened.
ATTENTION: Be certain that all screws are fully tightened before using chair.



OPERATING INSTRUCTIONS

To Adjust Seat Height:

While seated, reach the right side of the chair to find the handle. Lift and raise your body up slightly to allow the chair to rise to the desired height. To lower the seat, lift the handle while applying more weight downward on the seat. The chair will descend until the handle is released or the chair reaches the bottom position.

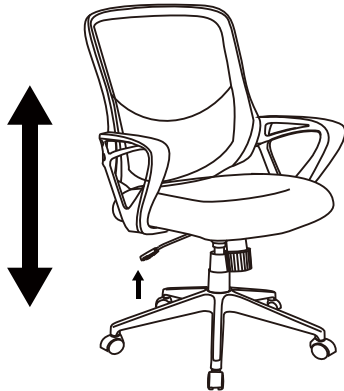

To Operate Tilt Lockout:

While seated, reach under the right side of the chair to find the height adjustment handle. Pull the handle all the way out (away from the gas lift) to allow the chair to tilt backwards. To lock the chair in the upright or vertical position, sit upright and push the handle in towards the gas lift.

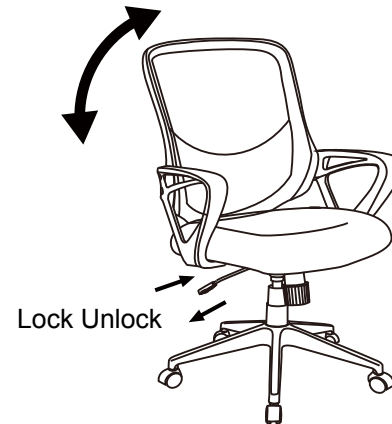

To Adjust Tension on the Tilt:

Reach under the front center of the chair, grasp the round knob and turn it counter-clockwise to stiffen the tilt mechanism. Turn the knob clockwise to loosen the tilt mechanism.

Rotate the knob until the desired resistance is reached.

360° Seat swivel.

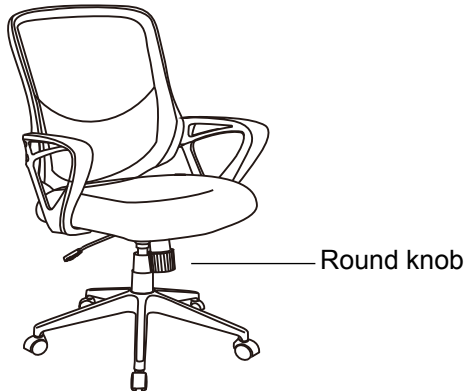

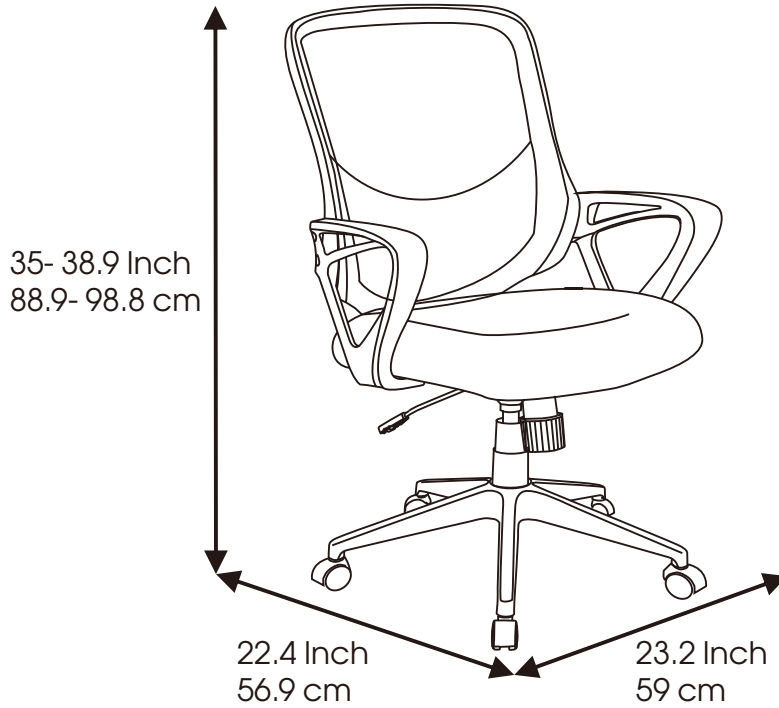

Product Dimension

Limited Warranty

The product you have purchased is warranted against defects in material and workmanship while owned by the "Original Purchaser". The term "Original Purchaser" is defined as that party or entity which purchases these products from an authorized dealer or retailer as shown by the original sales receipt. This warranty does not apply to "as is" or previously owned products.

The manufacturer warrants its products to be free from defects in materials and workmanship (normal wear and tear, fading and stretching excepted), for one year from the date of purchase, except as provided below under the limited warranty.

This warranty gives you specific rights, and you may also have other rights, which vary from state to state (or country to country). All warranties are limited to the original purchaser for normal use by a maximum of two users. Total weight capacity per chair is 250 pounds for a single user.

The exceptions or exclusions to this warranty are:

- Upholstery material and foam cushion material is warranted against defects in material and workmanship for a period of one year, beginning on the date of purchase as shown on the original sales receipt.
- Any warranty claim that is submitted after the limited warranty period, or without proper proof of purchase will not include the cost of parts, labor, or delivery on the warranted parts within a reasonable amount of time. We reserve the right to require damaged parts to be returned to us upon request. Natural markings such as scars, brands, grain variations, wrinkles, color variations, etc. will be considered normal characteristics and not construed as defects.
- For claims or questions concerning this warranty, please contact the Customer Service Department on the web at www.truecustomersupport.com. Be prepared to provide your name, address, daytime phone number, the model and purchase order number of the product, date of purchase, and the store where it was purchased. The manufacturer requires that the original sales receipt be submitted with all requests to confirm that you are the original purchaser according to our written warranty.

